

BED/TROLLEY RETENTION BLOCKS. TWO PER TYNE, ADJUSTABLE ALONG THE LENGTH OF TYNE AND FITTED WITH CLAMPING LEVER TO LOCK IN PLACE. MACHINED NYLON BLOCK TO REDUCE RISK OF DAMAGE TO BED/TROLLEY.

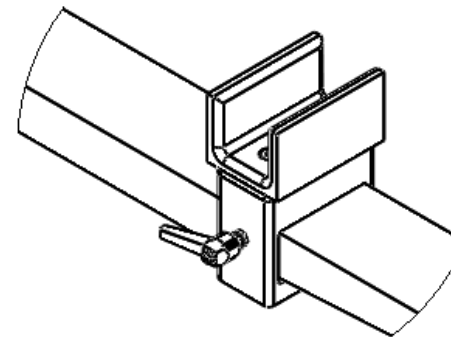

DETAIL A
 SCALE 1 : 5

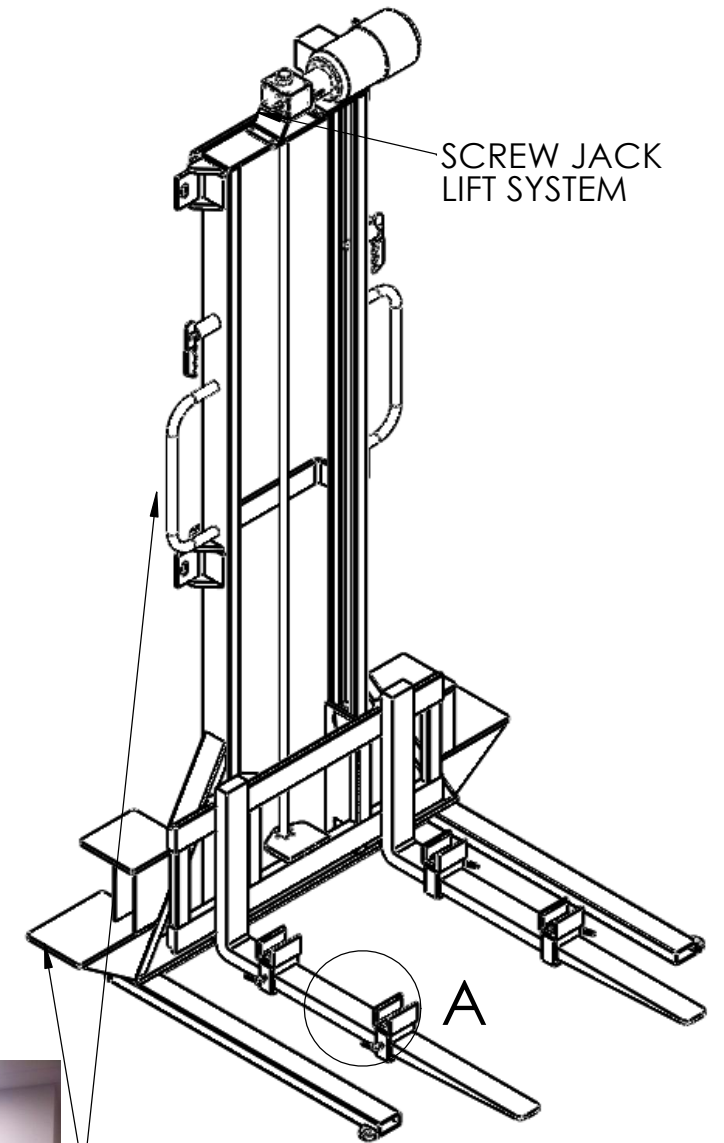

DUE TO THE HEIGHT OF THE CARRIAGE CHOCKS, STEPS AND A HANDLE HAVE ADDED TO THE MAST TO ALLOW FOR SAFE OPERATION OF THE CHOCKS. THE STEPS WILL BE COVERED WITH ANTI-SLIP TAPE.



PLEASE NOTE: THE CONTROL POINT IS NOT SHOWN IN THIS DRAWING. IT WILL BE MOUNTED WITHIN 2m OF THE LIFT SITE.

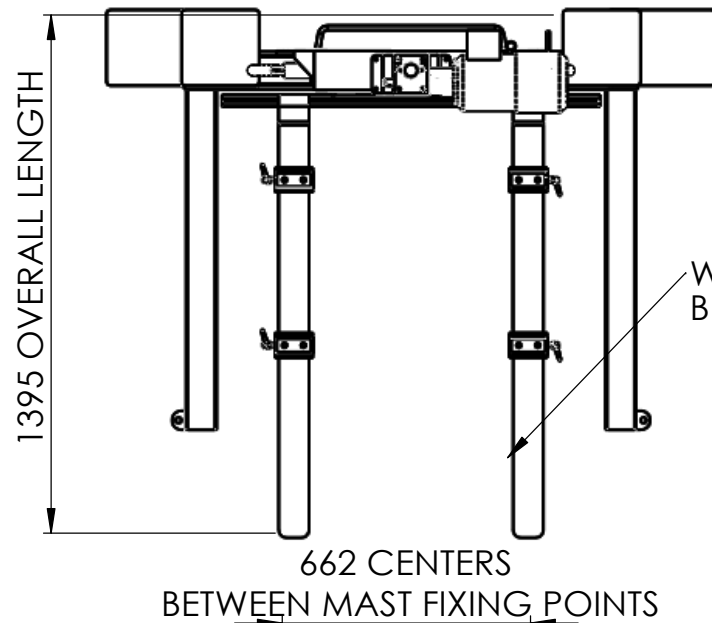

WIDTH OVER FORKS ADJUSTABLE BETWEEN 200mm AND 1000mm.

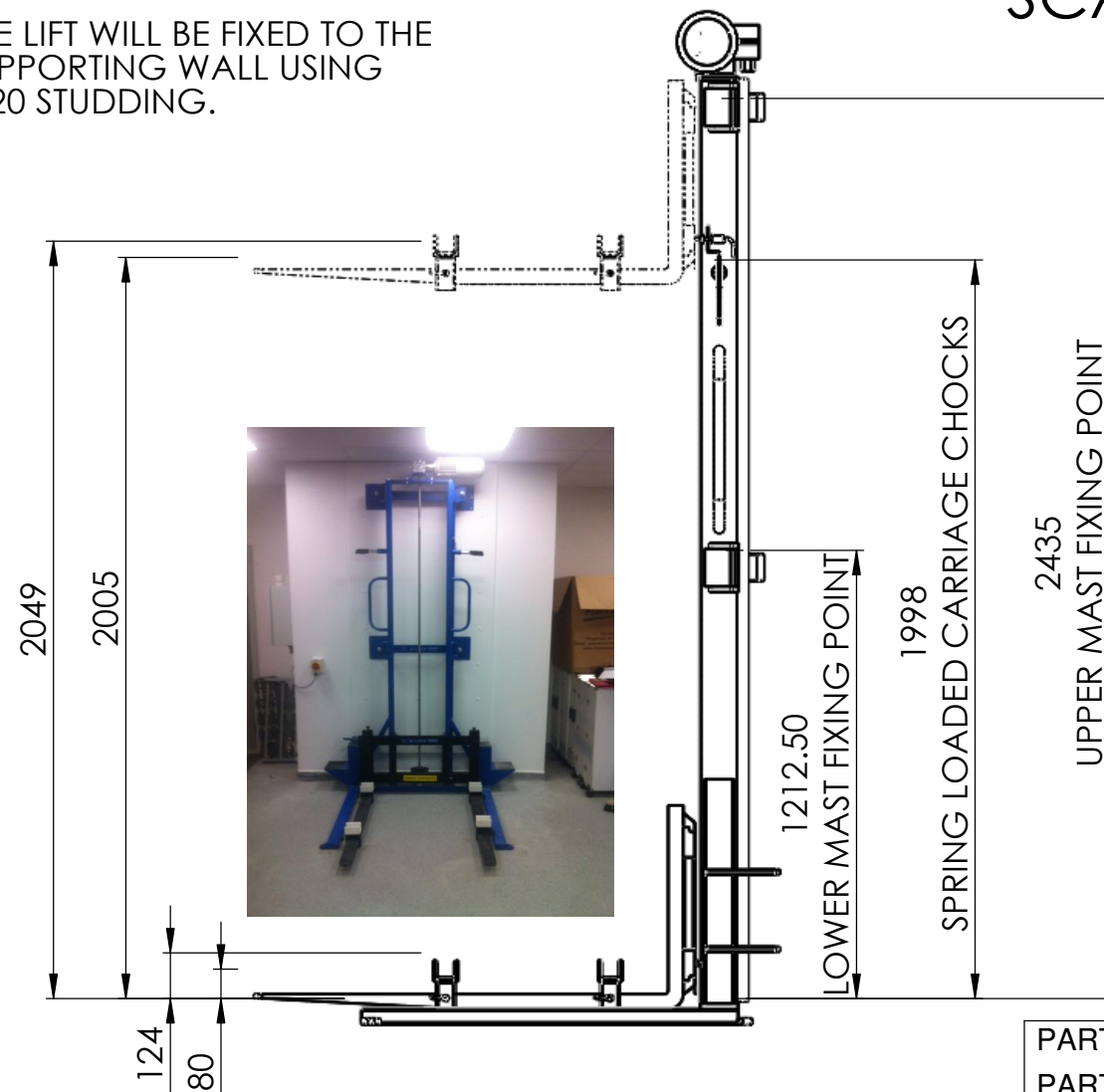
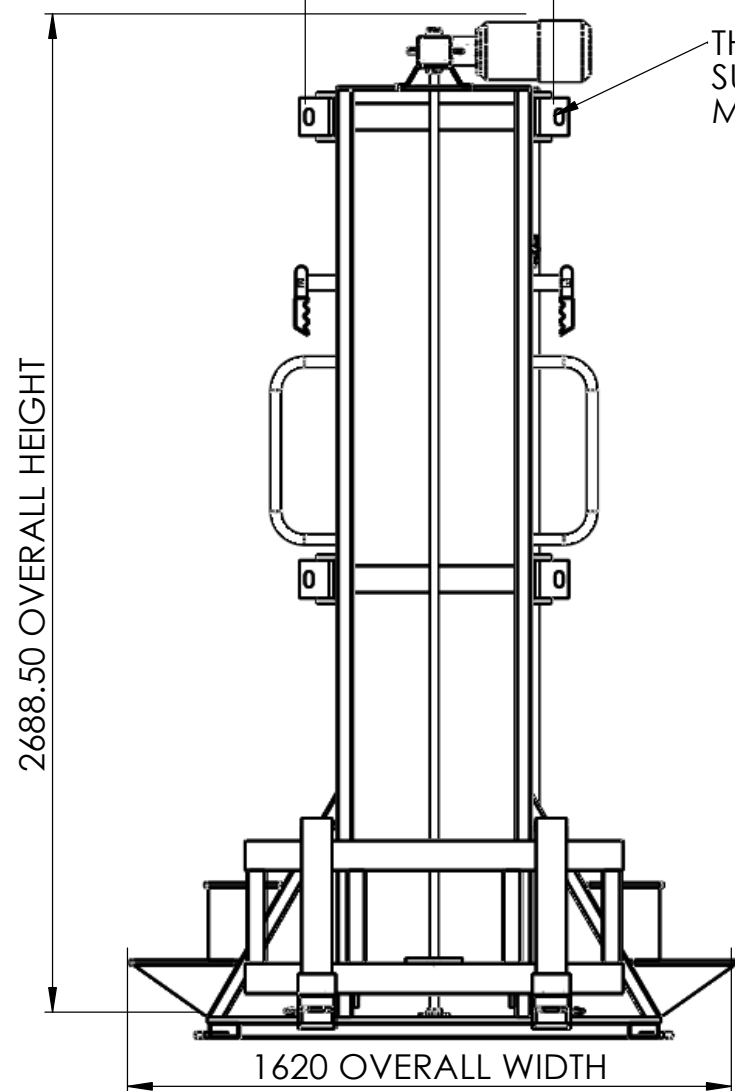

ALL DIMENSIONS IN mm. GENERAL TOLERANCE OF 0.5mm UNLESS OTHERWISE SPECIFIED THIS DRAWING FORMS PART OF A REGISTERED DESIGN

-	-	XX.XX.XX
-	-	XX.XX.XX
B	SHORTENED TO FIT BELOW 2700MM CEILING HEIGHT	XX.XX.XX
ISSUE	DESCRIPTION	DATE

PART No: SP-MZL-13512B		No. OFF.
PART NAME: SPECIAL BED LIFT - SWL 250kg		1
MATERIAL: AS PER INDIVIDUAL ITEMS	DRN BY: SLL	
FINISH: AS PER INDIVIDUAL ITEMS	DRN: 29/02/2012	
DRAWING. No: D-SP-MZL-13512B-B	SCALE: 1:20	
	ORIGINAL SHEET SIZE:	
	A3	

