

**ENCLOSURE: 1760mm x 1660mm**  
**PLATFORM: 1450mm x 1410mm**  
**USABLE AREA: 1350mm x 1350mm**

IF IN DOUBT ASK

**Description:** Goods only mezzanine floor lift, with no operator access to platform for loading/unloading  
**Capacity:** 300kg uniformly distributed over platform  
**Enclosure:** Free standing for positioning adjacent to mezzanine floor  
**Gates:** electrically and mechanically interlocked  
 Enclosure extending approximately 2.3m above mezzanine floor  
 Access through gate 1.9m high  
**Controls:** Hold to run controls at both levels  
**Duty cycle:** One operation every 15 minutes  
**Power requirements:** 13 Amp, single phase, 240 Volt  
**Lift mechanism:** Direct motor on chain drive  
**Structure:** Enclosure to be three sections:  
 Standard lower section (2m high) supply fully assembled and wired with platform installed  
 Upper section (2.3m high) - standard c/w limit switch and gate interlock supplied wired with long cable lengths with plugs for easy installation.  
 Mid section - built to order to achieve height required

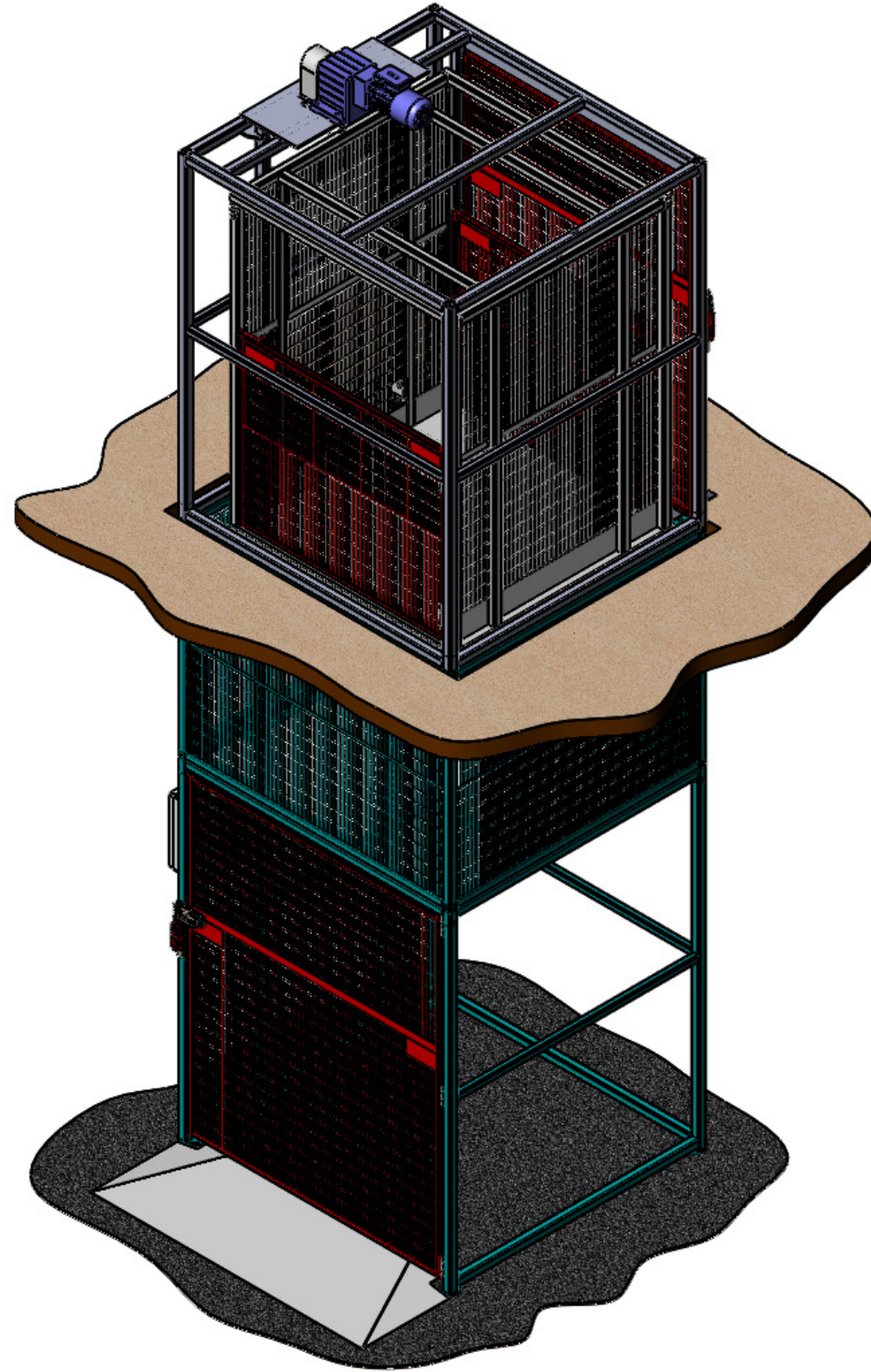

**Manual Handling SOLUTIONS**

REV.	DESCRIPTION	DATE
B	RE-ISSUED	29/05/2013
A	ISSUED DRAWING	14/05/2013

THIRD ANGLE PROJECTION

UNLESS OTHERWISE SPECIFIED (ALL DIMENSION IN mm)

**DIMENSION TOLERANCES**

LINEAR - ±0.5mm  
 HOLES - ±0.1mm  
 ANGLES - ±1°  
 RAD/CHAM - ±0.5mm

REMOVE ALL BURRS AND SHARP EDGES

PART No: SP-MZL-33883		No. OFF. 1	
PART NAME: "MEZLITE" 300kg, 3500mm FLOOR HEIGHT			
MATERIAL: SEE COMPONENTS	WEIGHT: 1371.2 kg.	DRAWN: O.TESU	APPROVED: D.GOSS
FINISH: TBD	DRAWING. No: D-SP-MZL-33883-Presentation-A-B	DRAWN: 29/05/2013	SHEET: 1 OF 2
		SHEET SCALE 1:30	DO NOT SCALE
		ORIGINAL SHEET SIZE: <b>A3</b>	

IF IN DOUBT ASK

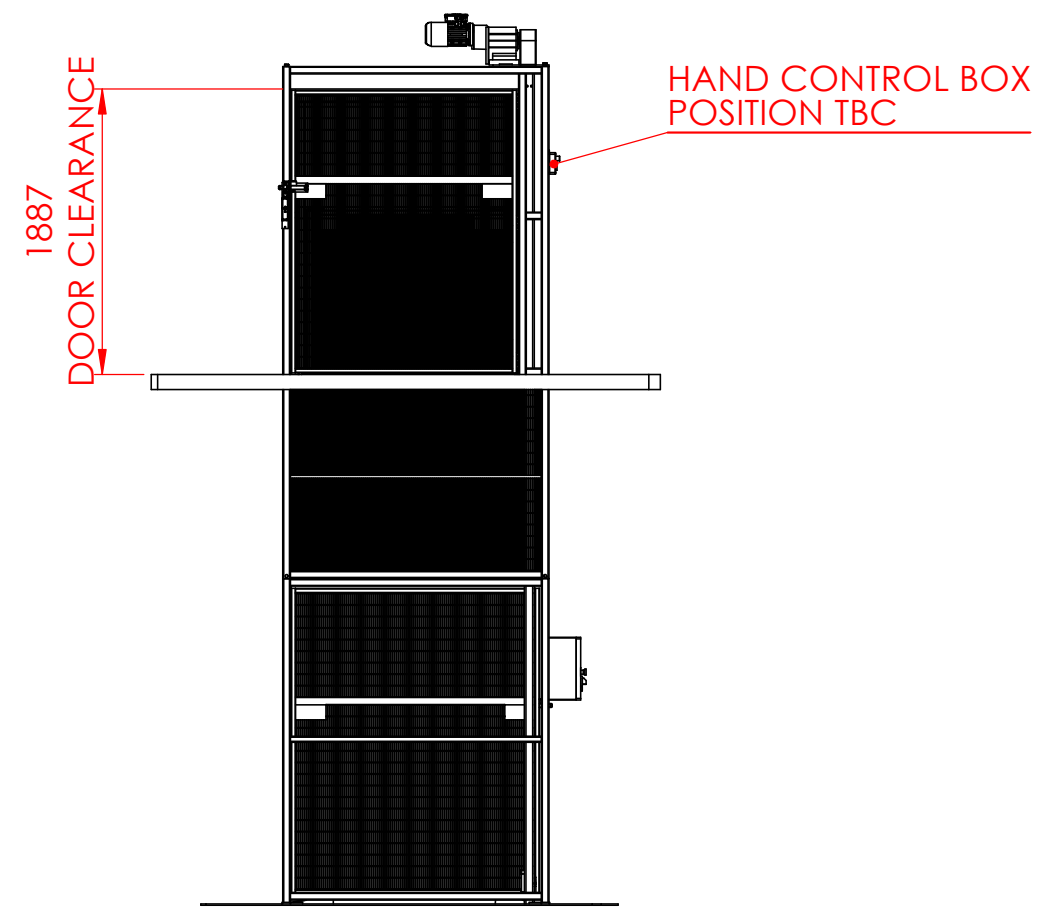
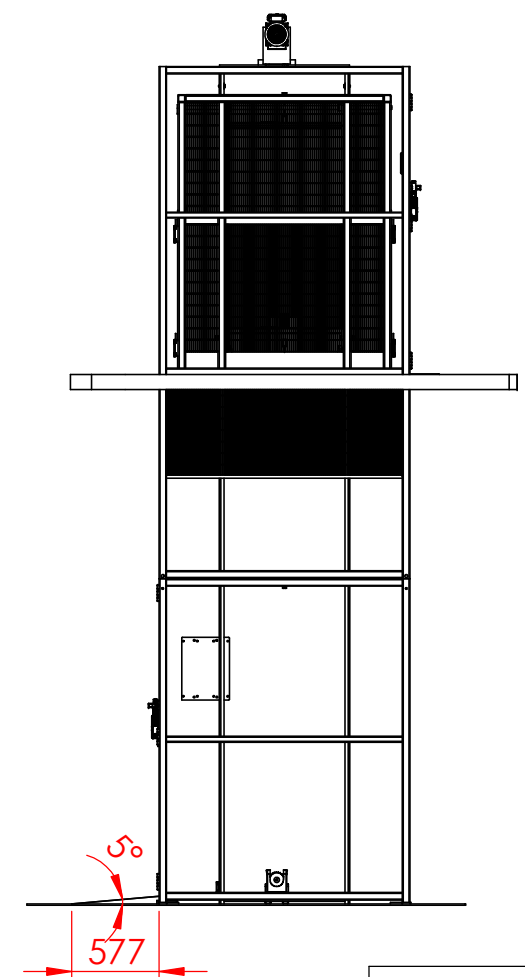
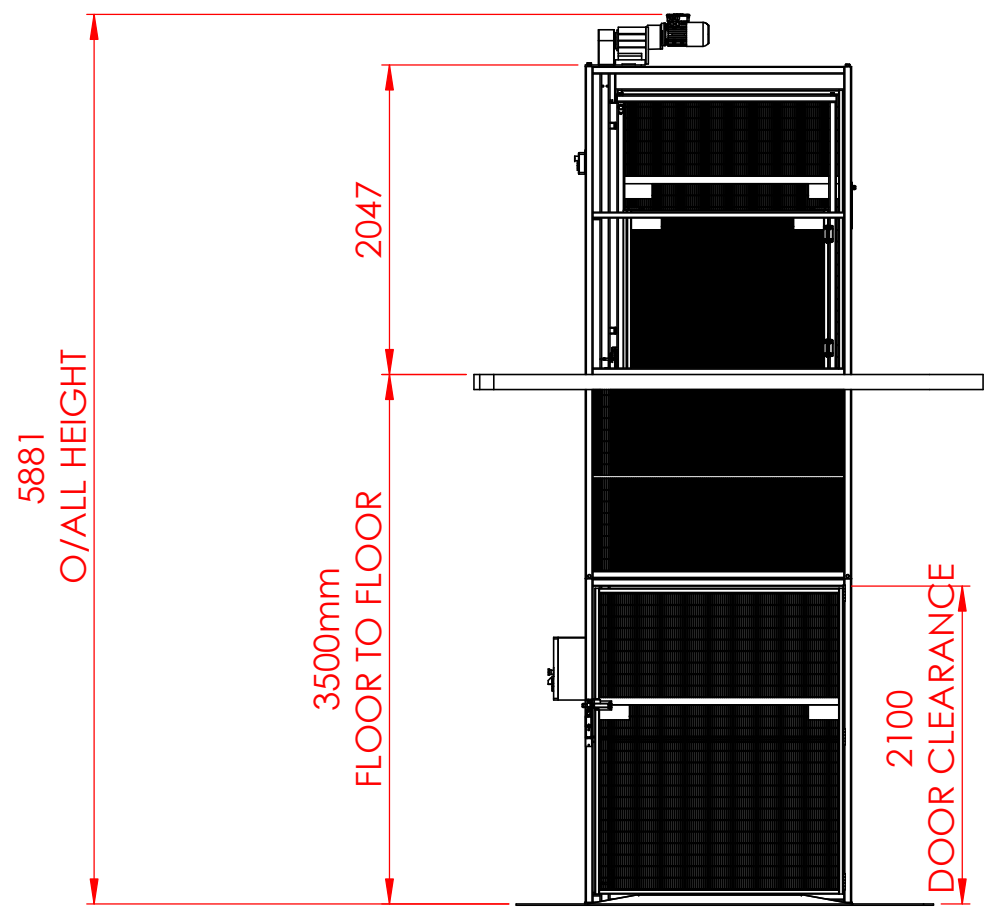
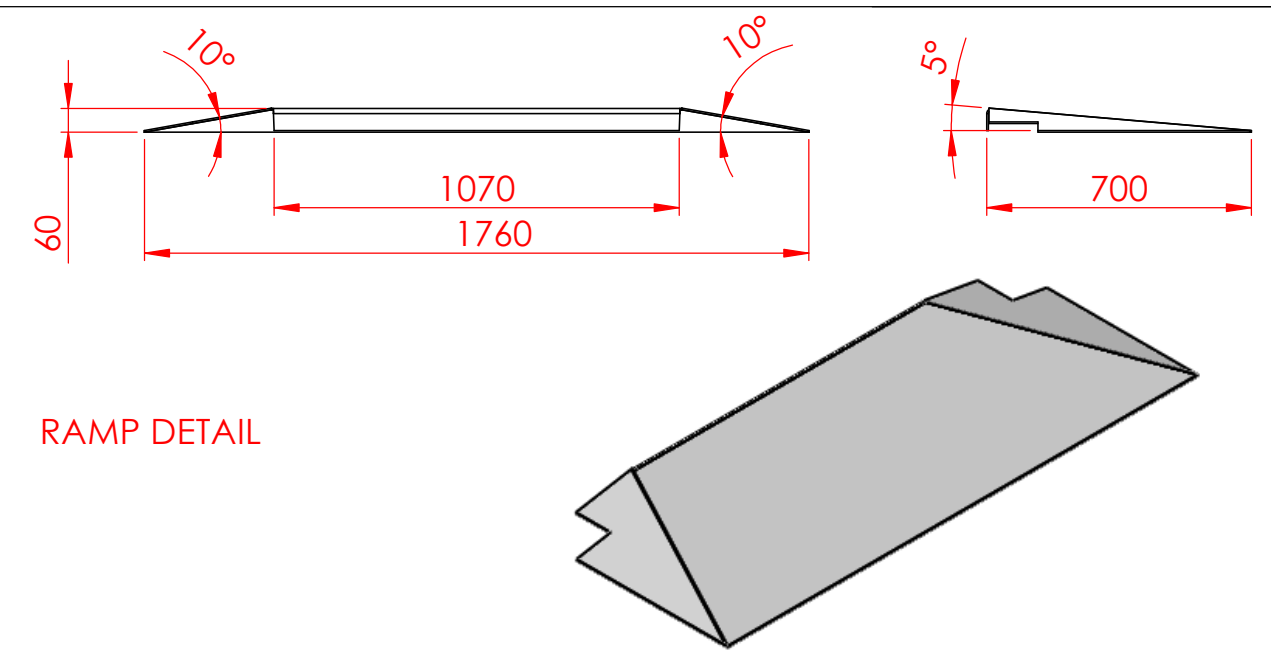
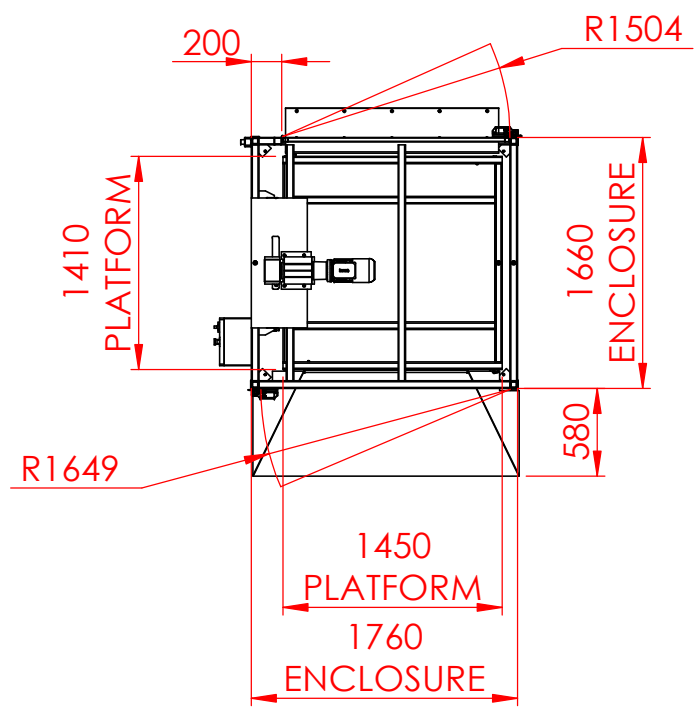

\* PLATFORM THICKNESS

REV.	DESCRIPTION	DATE
B	RE-ISSUED	29/05/2013
A	ISSUED DRAWING	14/05/2013

THIRD ANGLE PROJECTION

UNLESS OTHERWISE SPECIFIED (ALL DIMENSION IN mm)

**DIMENSION TOLERANCES**

LINEAR - ±0.5mm  
 HOLES - ±0.1mm  
 ANGLES - ±1°  
 RAD/CHAM - ±0.5mm

REMOVE ALL BURRS AND SHARP EDGES

<b>PART No: SP-MZL-33883</b> <b>PART NAME: "MEZLITE" 300kg, 3500mm FLOOR HEIGHT</b>		No. OFF.
MATERIAL: SEE COMPONENTS	WEIGHT: 1371.2 kg	DRAWN: O.TESU
FINISH: TBD	APPROVED: D.GOSS	
DRAWING. No: D-SP-MZL-33883-Presentation-A-B	DRAWN: 29/05/2013	
Tel 01553811977 Manual Handling Solutions		SHEET SCALE 1:50
ORIGINAL SHEET SIZE: <b>A3</b>		<b>Manual Handling SOLUTIONS</b>