

Briquetter from Metso Recycling
Metso EtaBriq®

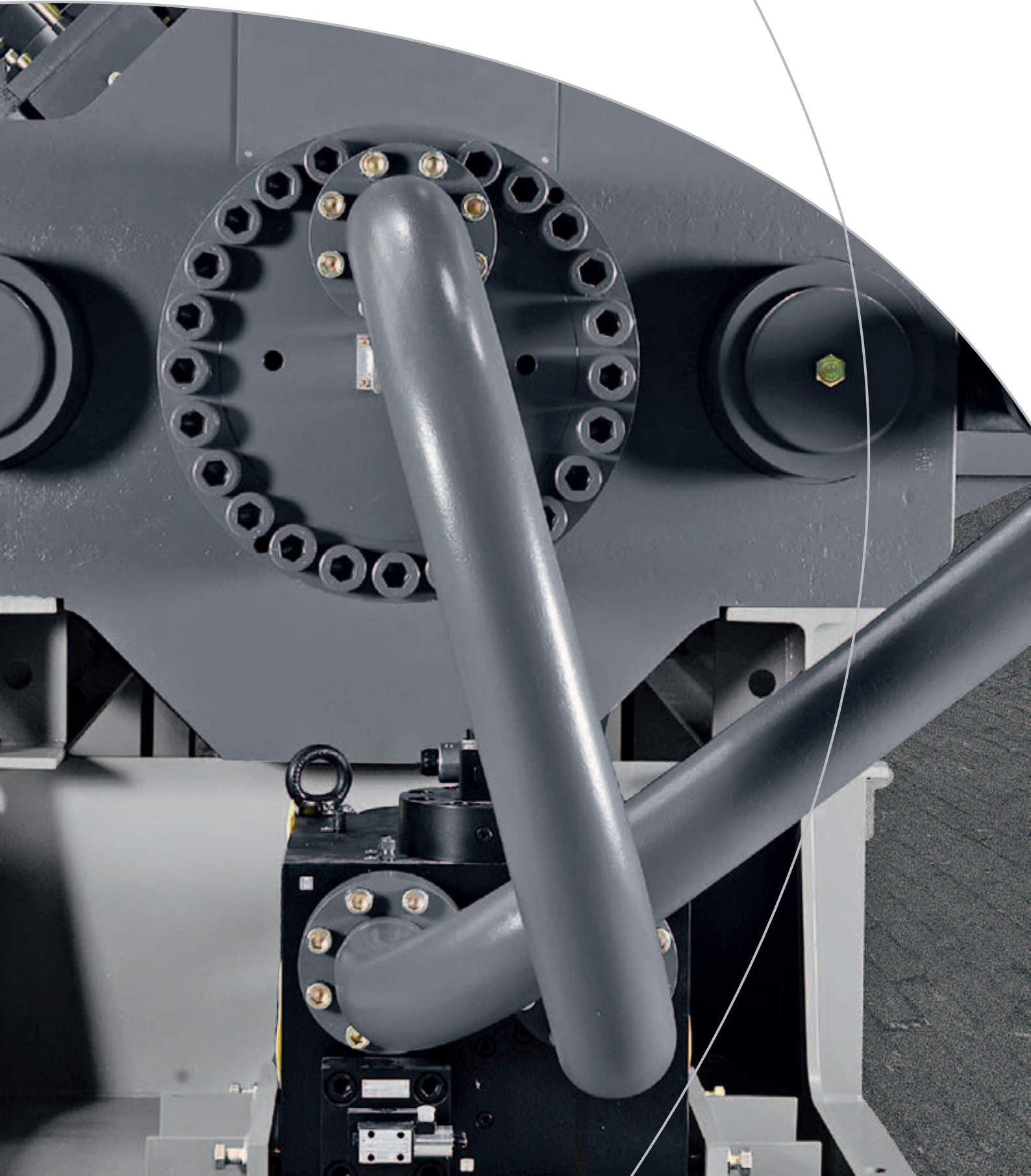

Recycling technology based on years of experience

Our experience is your advantage

Experience is invaluable when constructing machines which in spite of being subject to highest stresses must work reliably for decades. Metso Recycling has been manufacturing briquetting presses for many decades and our machines are operating today all over the world. The design principles have been constantly improved over the years, and we are proud to be able to set the market standards.

The continuous feedback from our customer combined with our knowledge enable us to tread new paths in order to meet the ever changing requirements of the market. As one of the few manufacturers, Metso Recycling is able to supply complete chips processing plants, ranging from chips crushing, screening, transportation, processing, and intermediate storage to the finished briquette.

Metso Recycling has been a role model right from the beginning

We have developed and manufactured chips briquetting presses since as early as the 1920s. More than 90 years' experience could be incorporated in the design of the Metso EtaBriq® 630. Metso Recycling briquetting presses are always among the most innovative. With the two-sided compaction principle of the Metso EtaBriq®, standards in terms of briquette quality and throughput capacity are challenge.



An advertisement from 1959

The briquetting technology is among the most updated

As the only supplier worldwide in this performance class, we apply a compaction principle that results in distinctly higher performance combined with great efficiency. The feedstock is compacted from two sides instead of one. The advantage is outstanding briquette density and a throughput capacity of up to 9.8 tons per hour.

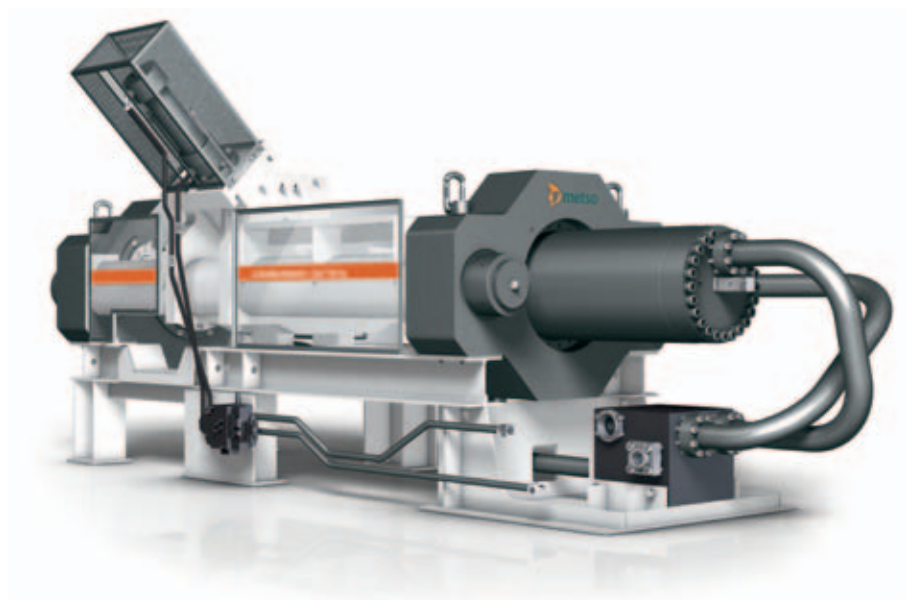

The chips processing adds value

Our technology upgrades scrap into a highly coveted raw material

The disposal of unprocessed metal chips is not particularly lucrative. Through high-quality processing, on the other hand, raw material can be converted into a source of income. A Metso Recycling briquetting press shows a positive Return on investment in less than 2 years, with an average service life of 15 years.

The Metso EtaBriq® press is a high-performance machine, designed to process large quantities of chips, both in the metal-processing industry and the recycling sector. It processes chips of cast iron, steel, aluminum, copper, and brass. Good results are also achieved in the briquetting of grinding sludge mixed with chips. The goal is to produce high-quality briquettes for cost-optimized disposal and sale to the end users at the best prices.

3 advantages of high-density briquettes produced with the Metso EtaBriq®:

1. Better logistics: reduced volume resulting in lower storage and transportation costs combined with high impact and wear resistance
2. Easier handling and better metering when re melting
3. Better sale: increase in the melting-down efficiency = less melting loss and, thus, higher metal yield



Metso EtaBriq®

The most efficient briquetting press on the market

The briquette length and density is flexible

The briquette length and density can be flexibly adapted to the feedstock and the end customer's requirements. Briquettes of optimum quality are always produced with maximum throughput capacity and minimum wear. The control system of the machine automatically adjusts.



More profit on resale

Due to the unique Metso Recycling double-sided pressing technology, the Metso EtaBriq® produces superior high-density briquettes. Apart from increased impact resistance when transporting, the metal industry gives priority to better quality. Metso EtaBriq® briquettes sink more quickly into the molten metal bath and lose less substance as a result of abrasion or surface burning.



The installation is flexible

The entire hydraulic system, including pumps, tank and electronics, can be installed away from the briquetting press. Separate areas can be equipped for production and the hydraulic unit, which improves the working conditions and increases protection of the components enormously.



More ease to maintenance

Bolts are used to tension the tie rods that absorb the enormous pressing forces. They can be tightened or loosened without a special tool. Thanks to the remote diagnosis system (optional), Metso Recycling technicians can access the control system and problems can often be solved directly, or preparations made for repair work in a cost-saving manner.

Reliable and precise

The non-contact position measuring system allows optimum movement control of all cylinders and, also the preset briquette length to be adhered to. Internal installation protects against damage – there are no interference-prone, external position switches.



The pressure line is very efficient

The large-volume pipelines of the Metso EtaBriq® are bent instead of being welded together. The result is less targets for leakages and minimized pressure losses in the flow pattern.

More power due to the excellent hydraulic system

Metso EtaBriq® operates with modern high pressure technology of 350 bars. The hydraulic system has standard features that cost extra at other manufacturers, internal position measuring systems in all cylinders, tank heating system as standard equipment, oil transfer system, oil filtering in the secondary circuit.

Oil losses can be monitored

The electronic oil-level monitoring system detects even the smallest oil losses at an early stage and reports these at the display. This protects not only the hydraulic system, but also the environment from damage and you reduce downtimes.

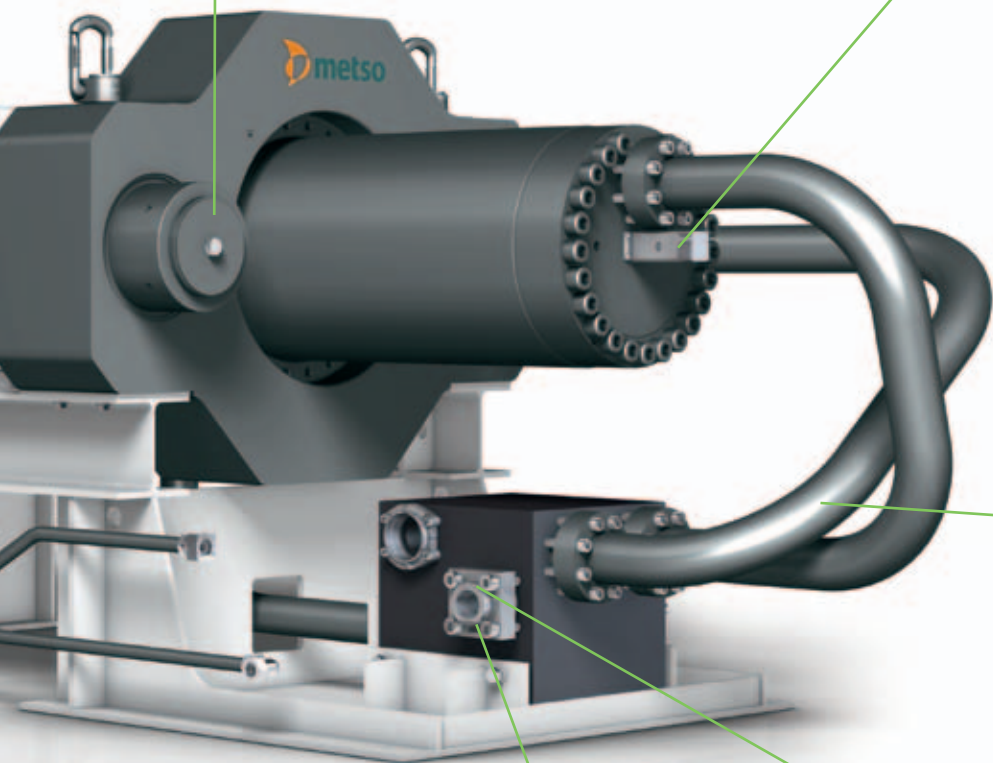

Double-compacted sells better providing pressure from two sides for higher quality

The further processing industry demands the highest quality in recycled products. Therefore Metso Recycling has developed a two-sided compaction principle for briquetting. Instead of only being pressed from just one side, the briquettes are pressed by two cylinders with up to 40,000 N/cm², with minimum frictional losses. The results are briquettes of excellent quality which are produced with low energy consumption.

A machine that's standing still doesn't earn any money. Metso EtaBriq® has due to the two sided compaction technology a closed filling pipe, no cutting is required – consequently, the edges are subject to less stress and abrasion. The result is less wear and less maintenance and minimum production downtimes.

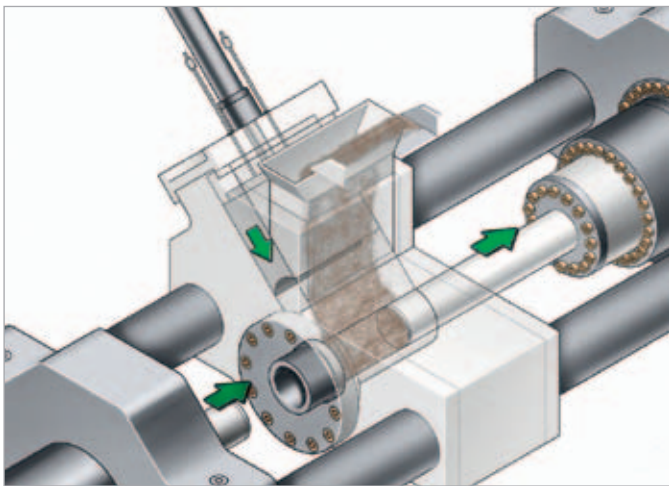

1. Filling

The material to be briquetted slides into the filling chamber while the main compaction cylinder moves back and the counter compaction cylinder moves forward. The filling chamber is closed.

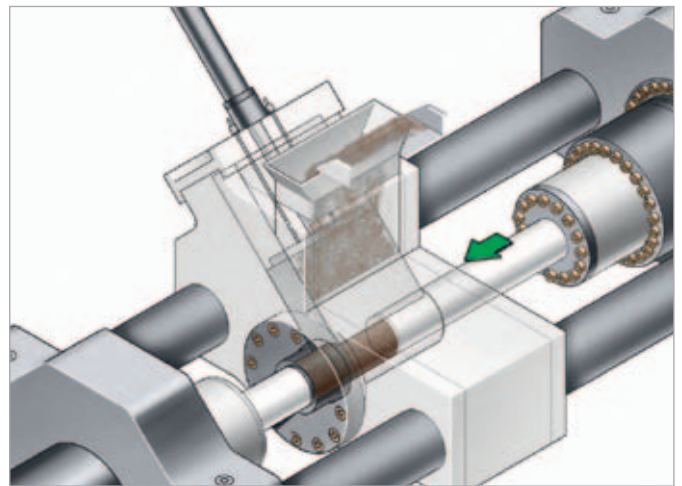

2. Pre-compaction

The main compaction cylinder pushes the material to be briquetted into the compaction bushing. Cutting of the material and the wear connected with this are avoided.

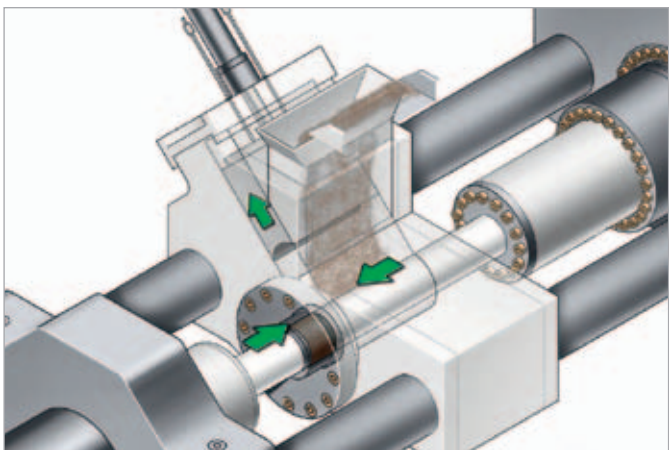

3. Compaction

Pressing forces accumulate between the two compaction rams and a high-density briquette is produced. During the compaction process, the pre compactor moves up again and new material slides in.

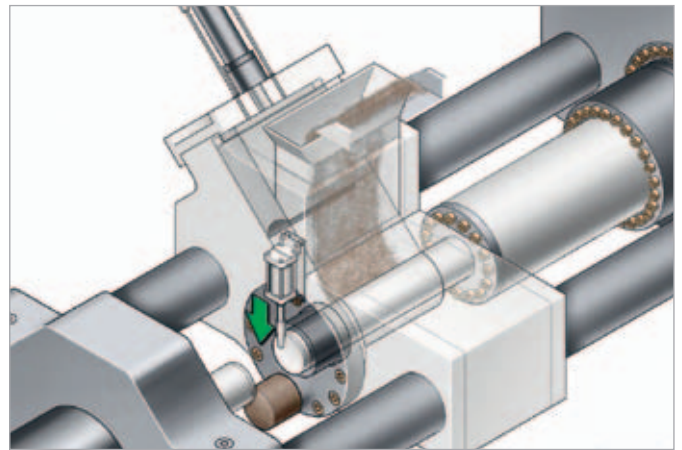

4. Ejection

The main compaction cylinder moves forward again and ejects the briquette. The stripper reliably ensures separation from the compaction ram even with difficult materials.

Performance up and costs down

The shortest downtimes and the highest energy yield mean high efficiency

If you value efficiency these are the facts:

1. The virtually literal manufacturing quality of Metso Recycling ensures incomparable mechanical precision as optimum resistance to wear and failure.
2. Metso Recycling's own two-sided compaction technology minimizes abrasion losses and generates force where it is needed, i.e. on the briquette.
3. The two-sided compaction in a pressing pipe reduces wear on the pressing tools, because they don't need to cut through the material to be briquetted.
4. The control electronics are controlled by our own software and allow optimal use of the hydraulic power and ensure a trouble-free process.



Compact whatever you like

Metso EtaBriq® presses process virtually all types of crushed chips alloyed and unalloyed steel, castings, aluminum, brass, copper, swarf, and sludge. The chips are fed in and metered via a conveyor. Dry aluminum, alloyed steel or cast iron, place highest demands on the briquetting, the optional spray unit lubricates the tools with pinpoint accuracy at the point of use and increases the service life of wear parts.



Maximum output quality ensures maximum profits

Metso EtaBriq® produce briquettes in the quality demanded by the processing industry and which is well paid. The two-sided compaction technology produces an extremely high material density. The result is a briquette which sinks more quickly when melting down. Losses are minimized as considerable less of the valuable feedstock burns on the surface of the melt. The briquettes are more stable when being transported and loose less substance as a result of oxidation when stored.



Optimize processes, maximize flexibility

What is the point of power without an intelligent control system? Via internal noncontact position measuring systems, the PLC system continuously monitors optimal movement of the cylinders pistons. The compacting process is low-vibration and cycle-optimized. The adjustable briquette length ensures maximum throughput. The oil level is automatically monitored and leakages detected at an early stage. A modern control panel enables easy control of the machine and provides information on the status of the machine, the hydraulic system and production output.

Metso Recycling's way of making a plant

Others build machines; we offer solutions for comprehensive processing

As market leader in mechanical engineering for metal recycling, we place great value on offering our customers profit-increasing processes instead of leaving them alone with "isolated applications". We have experience in converting the complex requirements of different branches into plant concepts that ensure trouble-free production processes and achieve optimum results for our customers.

Metso Recycling has already planned and installed numerous chips processing plants around the world to be supported by service engineers in more than 30 countries. We offer, in addition to the installation, a customer-oriented advice and support.



Preparation increases the yield

Not every chip can be briquetted directly. Effective preparation with upstream components maximizes utilization of the briquetting press: for instance, the moisture in the chips can be reduced, which increases the briquette quality. The screening of coarse parts protects the press against unnecessary damage and, thus, from production downtimes. Continuous operation due to storage bunkers with automatic feed increases the efficiency of the plant: a briquetting press that can run around the clock earns more money.

You may have many requirements, we have one solution you only need one partner

The advantages of having one partner that can supply and install complete plants are obvious: only someone who has an overview of the complete project can also develop precise interlocking concepts. Possible extensions and modifications are always taken into consideration right from the beginning. The trouble-free integration of the individual components are our responsibility, not yours.

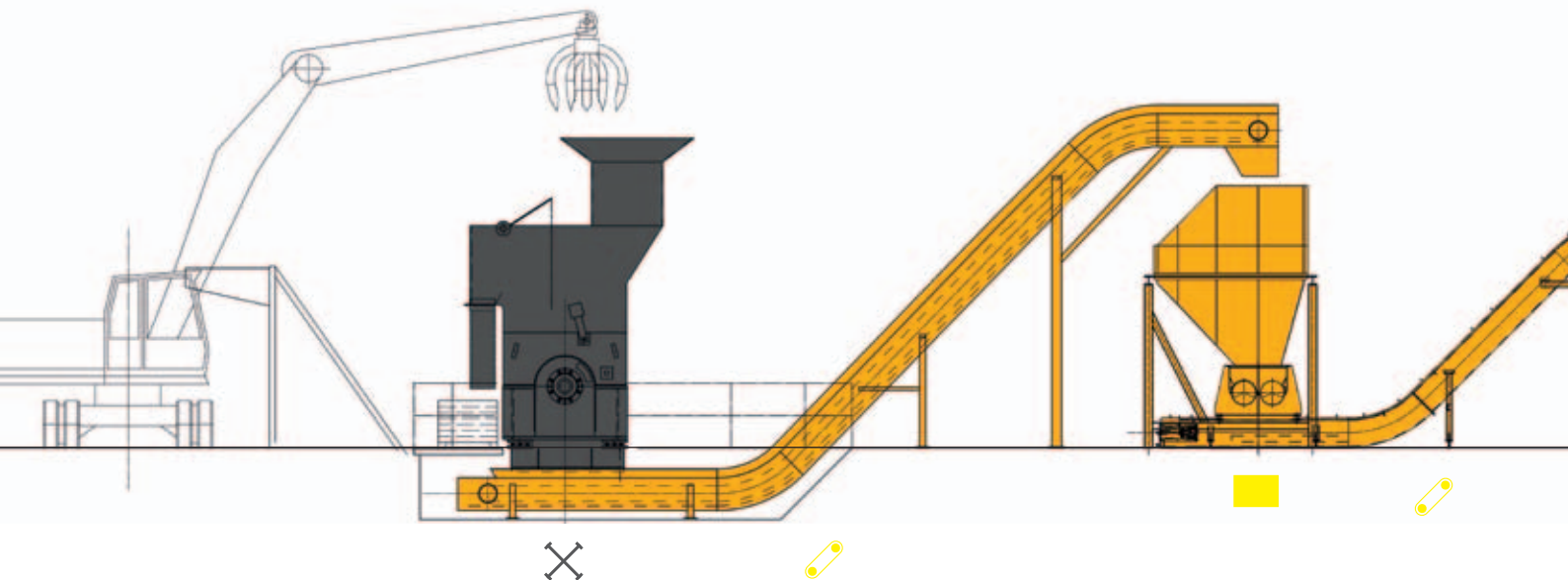



Metso turnings crusher

For processing bushy and long turnings to produce shovel able material that is optimal for storage and transportation. Effect: optimally prepared feedstock for maximum efficiency of the briquetting press.



Bunker

For stockpiling and continuous feeding of crushed and flowable chips. Effect: better utilization of the briquetting press, low transportation cost/time.



Magnetic separation

Gives you reliable separation of ferrous metals to ensure the purest non-ferrous briquette quality. Effect: better sales arguments and more profit.



Conveyor belts

For transporting uncrushed or crushed chips, in a hinged belt or scraper version. Effect: flexible integration in the local workflow and infrastructure.



Screening technology

For separating heavy parts – as a drum screen or vibrating channel, depending on the application. Effect: protection against unnecessary damage and excessive wear.



Centrifuge

For reliable minimization of oil and cooling lubricants in the briquettes, as well as for recovering cooling lubricants for recycling. Effect: dryer briquettes, better sales arguments and more profit.



Vibration conveyor

For precise metering of the chips to be briquetted. Effect: better utilization of the briquetting press.



Metso EtaBriq®

With two-sided compaction technology for high efficiency, continuous operation and optimum briquette density. Effect: optimum technology for maximum yield.

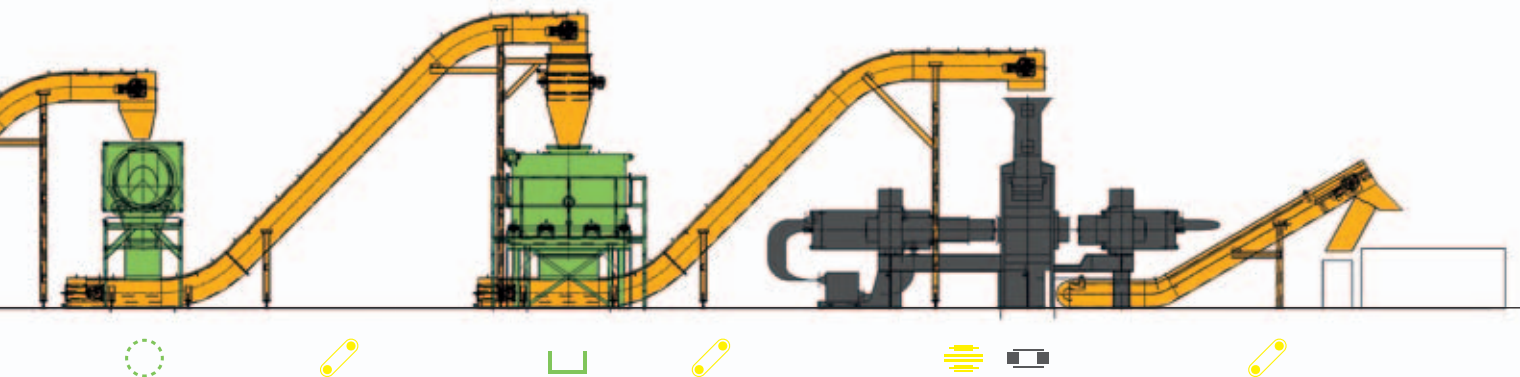

Metso EtaCrush®

Perfectly prepared material helps you to earn more money

Turnings do not have to be bulky, sharp-edged and hazardous. They do not have to get tangled up in inextricable bundles, take up lots of storage space and be uneconomical to transport. Metso Recycling's turnings crushers prepare long, curly, bushy, and voluminous turnings of steel, aluminum, brass, and other metals economically to form easy to shove material that can be stored or loaded excellently and is cheaper to transport. The outstanding crushing technology ensures a high throughput capacity, more protection against coarse parts and optimum economic efficiency. As a component of a turnings processing plant, a Metso EtaCrush® is a performance driver for an optimal throughput capacity.

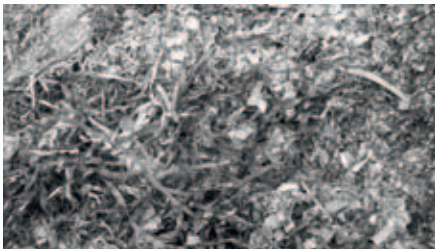

Sophisticated material feed

Large feed openings, optionally positioned on the side or top, ensure flexible and trouble-free material feed.

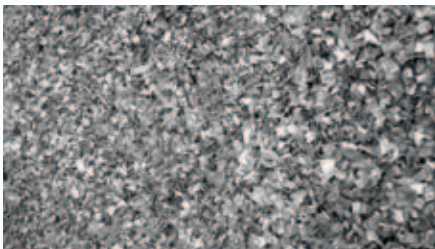

Metso offers the best crushing technology

Metso EtaCrush® operates with extremely wear-resistant, freely suspended crushing tools instead of sensitive blades. The generously dimensioned flywheel mass of the disc rotor ensures high power: the turnings are torn into regular, fine pieces.



Protection against malfunctions

The tools are relatively immune to solid parts such as screws, nuts and bolts that are consistently found in turnings. If these coarse parts do not drop through the openings in the grid, they are ejected without difficulty via the coarse parts ejector. This helps to reduce wear and to prevent damage to a great extent.

What is in a plant?

The whole is better than its parts? When it all fits together perfectly

It should go without saying that the world market leader in metal recycling technology will provide an excellent technical solution for a chips processing plant. But we also set great value on executing our projects at the lowest cost for our customer. As a part of the globally acting Metso Corporation, we can utilize a global personnel network and have experience in perfectly coordinating complex projects worldwide.

1

From the analysis to the concept

We analyze the requirements to be met by the project and, together with the customer, develop a plant concept that includes all necessary components. In this context, the feedstock and the desired end product are just as important as the circumstances on site. Due to our experience with numerous installed plants worldwide, we can develop the optimum process sequence and the machine configuration needed for this.

2

From planning to the offer in terms of cost and time

One can't be careful enough when it comes to money. Our planning defines the mode of procedure precisely and takes into consideration all relevant information such as machine capacities, process chains, costs, and timing. We check the compatibility of the individual components, as well as the interface to the customer's infrastructure. The transparent offer that allows a decision to be made is prepared only after close coordination with you the customer.

3

From manufacturing and installation to commissioning

No matter whether the installation is done by the customer or installed by Metso Recycling as a turnkey plant, we take over the work and coordinate - worldwide manufacturing, assembly and commissioning. Our engineers are present on site during installation to perform quality assurance. Our customers are provided with professional project management with a fixed contact person for all areas and are always kept informed about the progress of the project.

4

From commissioning to the annual check

We don't understand service to merely mean emergency assistance that is called when something breaks down. At the time of commissioning, our specialists remain on site until the plant components are perfectly tuned to each other and the customer's personnel have been trained to operate the plant. Even after the last Metso Recycling representative has left the installation site, we are close at hand. Thanks to Metso Recycling's worldwide service network and numerous service centers, our technicians are on site in no time.

Metso Recycling Equipment

Our range:

Pre-Shredders
Shredders
Shredder Plants
Metal Crushers

Scrap Shears
Turnings Crushers
Briquetting Presses
Double Screw Presses
Anode Crushers

Screen Drums
Scrap Baling Presses
Waste Fine Shredders
Waste Pre Shredders

Metso Recycling Services

Uptime Services

Inspection Services
Parts Services
Repair and Refurbishment
Troubleshooting Services

Performance Services

Process Monitoring Services
Optimization Services
Upgrade Services
Training Services

Project and Engineering Services

Start-up Services
Health, Safety and Environmental Services
Engineering Services
Plant Relocation Services

Metso Minerals, Austria

1230 Wien
Tel.: +43 18 13 65 080
E-Mail: recycling.info.at@metso.com

Metso Brasil Indústria e Comércio

18087-101 Sorocaba, SP
Tel.: +55 15 2102 1300
E-Mail: recycling.info.br@metso.com

Metso Minerals, China

Chaoyang District, Beijing 100022
Tel.: +86 10 6566 6600
E-Mail: recycling.info.cn@metso.com

Metso Minerals s.r.o., Czech Republic

628 00 Brno
Tel.: +420 544 425 522
E-mail: recycling.info.cz@metso.com

Metso Denmark

8700 Horsens
Tel.: +45 7626 6400
E-mail: recycling.info.dk@metso.com

Metso Minerals, Finland

01740 Vantaa
Tel.: +358 20 48 45 200
E-Mail: recycling.info.fi@metso.com

Metso Minerals, France

71009 Mâcon Cedex
Tel.: +33 3 85 39 62 00
E-Mail: recycling.info.fr@metso.com

Metso, Germany

40231 Düsseldorf
Tel.: +49 211 21 05 0
E-Mail: recycling.info.de@metso.com

Metso Recycling Business Line, India

Mumbai - 400710
Tel.: +91 22 39130000
E-mail: recycling.info.in@metso.com

Metso Minerals, Japan

Yokohama 222-0033
Tel.: +81 45 476 3935
E-Mail: recycling.info.jp@metso.com

Metso Recycling Business Line, Korea

Seocho-gu Seoul
Tel.: +82 (0) 2-582-1507
E-Mail: recycling.info.kr@metso.com

Metso Mexico S.A. de C.V.

CP 36541 Irapuato, Gto.
Tel.: +52 871 791 2180
E-mail: recycling.info.mx@metso.com

Metso Minerals, Benelux

3316 GC Dordrecht
Tel.: +31 78 61 86 888
E-Mail: recycling.info.nl@metso.com

Metso Minerals (Poland) Sp.z.o.o.

40246 Katowice
Tel.: +48 32 253 07 29
E-mail: recycling.info.pl@metso.com

Metso, Russia

125167 Moscow
Tel.: +7 495 739 88 80
E-Mail: recycling.info.ru@metso.com

Metso Automation Singapore Pte Ltd

Singapore 339411
Tel.: +65 6511 1011
E-mail: recycling.info.sg@metso.com

Metso Minerals, South Africa

Isando, 1600
Tel.: +27 11 961 4000
E-Mail: recycling.info.za@metso.com

Metso Minerals España, S.A.

28032 Madrid
Tel.: +34 91 82 55 700
E-Mail: recycling.info.es@metso.com

Metso Minerals, Sweden

261 62 Glumslöv
Tel.: +46 706 24 55 70
E-Mail: recycling.info.se@metso.com

Metso Dış Tic. Ltd. Şti., Turkey

06370 Ankara
Tel.: +90 312 387 3600
E-mail: recycling.info.tr@metso.com

Metso Recycling Business Line, UK

Rugby, Warwickshire, CV21 1QJ
Tel.: +44 17 88 53 22 55
E-Mail: recycling.info.uk@metso.com

Metso Minerals Industries, USA

San Antonio, TX 78216
Tel.: +1 210 491 9521
E-Mail: recycling.info.us@metso.com