

weko



Weko Spread-*i*t
Selvedge Decurlers
for Knits and Wovens

The WEKO Way of De-curling

The Purpose of De-curling

In textile machineries for knits and wovens curling causes process errors and waste of fabrics. Therefore, when curling is minimized, fabric yield increases and so does profit.

How Spread-*it* works

The fabric edge travels through the device and is clamped gently by the "fishbone" designed upper and lower plate. Curls are gently

grasped and spread outward.

This convincingly simple principle features low friction surfaces, thus treating the fabrics very gently. It easily adjusts to a variety of fabric conditions.

Fabric Ranges

From heavy double knits to light delicate single jersey. It is also useful for fabrics containing elastans.

Type of Machinery

- stenter entries
- cylinder dryers
- foulards before pinch roller
- pads
- printing machine entries
- compactors
- sueding machine entries
- vacuum slot
- napping machines entries
- washing boxes
- inspection frames
- winding systems

Spread-*it* KS1701 De-curler for Stenter Entries

The KS1701 presents the optimum method for transferring fabrics onto stenter pin-rails while minimizing waste. The de-curling is carried out just before pinning. That leaves a minimum edge width that is later trimmed off.

Supposedly 3mm of edge is saved. Over a one years production it makes up to 30'000m² fabrics saved.



The Spread-*it* de-curler works jointly with the Nipp Roller 2RG4 (optional), shown in red in the picture.

The 2RG4 replaces the conventional belt system of other makers. It prevents re-curling between the de-curler and the pinning-up. The 2RG4 is proven to be more reliable than the belts.



Spread-*i*t KS2801

De-curler with space-saving design

The KS2801 is suitable for tight mounting situations.

Applications: stenters with clips, pads, compactors, print machines, foulards.



Spread-*i*t KFW

Full width control.

The KFW is dedicated to de-curling and spreading a web over its entire width. No setup works by operators needed. Especially in difficult to access areas in the machinery the operator can handle web changes easily and risk-free.

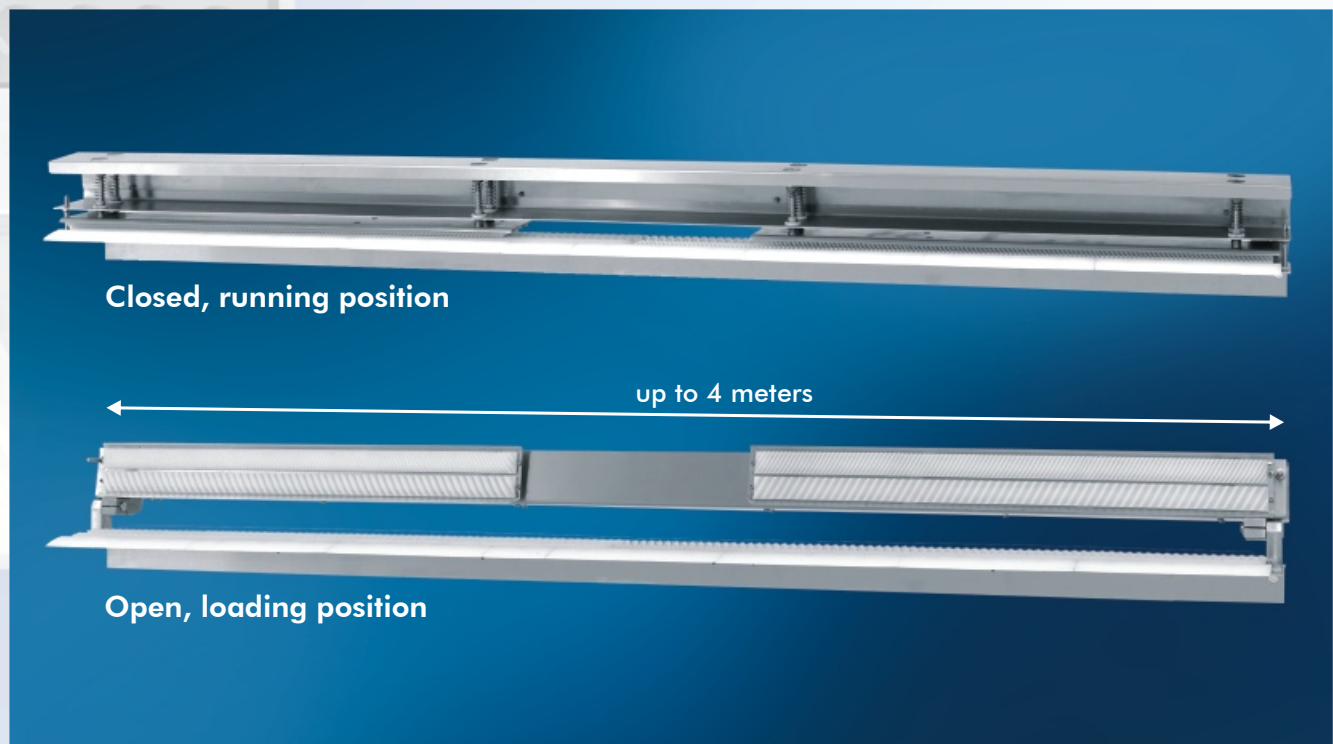
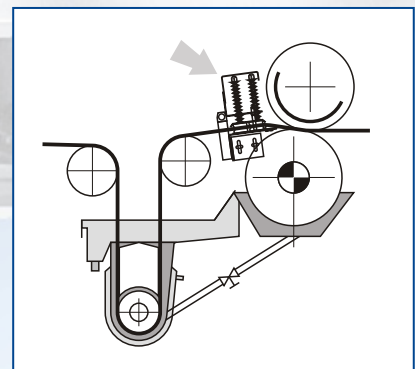

weko

WEKO Spread-*i*t - Key Points

Versatility

- Operates at all web speeds
- Functions equally well on dry or wet fabrics
- Functions equally well with curl-side up or down
- Operates at temperatures up to 100°C
- Adjustable to accepting various fabric types
- Space-saving design

Safety of process

- Low friction surface, thus no fabric picking, marking or distortion

Safety of operation

- No electrical parts, thus safe in wet areas such as foulards or washing machinery
- Risk-free handling in hard to access areas of the machinery

No Maintenance Cost

- No moving parts
- No electricity or compressed air required
- Possible elimination of scroll rollers



Sales and Production by Weko (Brazil)

WEKO América Latina
R. Albany, 140
89130-000 - Indaial - SC
Brasil
Tel +55 47 3333 1320
Fax +55 47 3394 7392
info@weko.net.br
www.weko.net.br

Weko Headquarters Germany:

Weitmann & Konrad GmbH & Co. KG
Friedrich-List-Strasse 20-24
D-70771 Leinfelden-Echterdingen
Germany
Tel +49 711 79880
Fax +49 711 7988114
info@weko.net
www.weko.net