

# INSTALLATION, COMMISSIONING & MAINTENANCE MANUAL

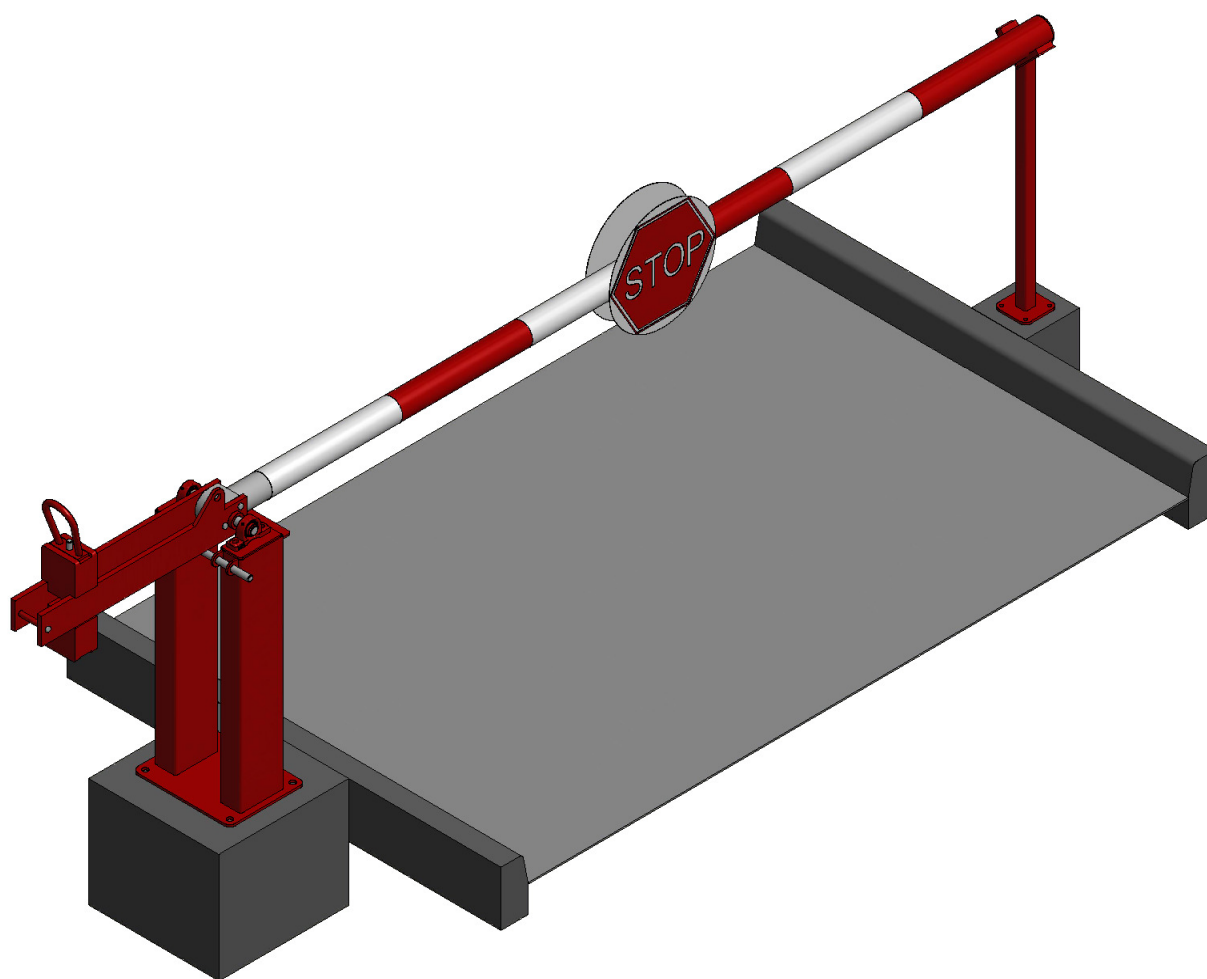

## MANUAL RISING ARM BARRIER

**Head Office:**

Phone: +44 (0)1636 700 172  
Fax: +44 (0)1636 605 400  
Email: [sales@newgate.uk.com](mailto:sales@newgate.uk.com)

**Service Department:**

Phone: +44 (0)1636 704 000  
Fax: +44 (0)1636 605 957  
Email: [service@newgate.uk.com](mailto:service@newgate.uk.com)  
(Out of Hours): +44 01636 653 302

## INDEX

Page No:

1. SAFETY INFORMATION	02
2. TECHNICAL DATA	03
3. GENERAL SAFETY STANDARDS	04
4. GENERAL DESCRIPTION	05
4.1. BASIC DESIGN	05
5. HANDLING	06
5.1. TRANSPORTING	06
5.2. LIFTING	06
6. INSTALLATION	07
6.1. FOUNDATIONS	07
6.2. BARRIER	08
7. MECHANICAL ADJUSTMENTS	09
7.1. BALANCE WEIGHT ADJUSTMENT	09
7.2. STOP SCREW ADJUSTMENT	10
8. COMISSIONING	11
9. OPERATION	12
10. MANUAL TRAFFIC BARRIER – GENERAL ASSEMBLY	13
10.1. MANUAL TRAFFIC BARRIER – EXPLODED DIAGRAMS	13
10.2. MANUAL TRAFFIC BARRIER – PARTS LIST	15
11. MAINTENANCE	16
11.1. BEFORE CARRYING OUT MAINTENANCE	16
11.2. WHILST CARRYING OUT MAINTENANCE	16
11.3. AFTER CARRYING OUT MAINTENANCE	16
11.4. ORDERING SPARE PARTS	16
11.5. SERVICE SCHEDULE	16
11.6. REPLACING POLE ARMS	17
11.7. REPLACING POLE ARM ADAPTORS	18
11.8. METHOD STATEMENT	19
11.9. RISK ASSESSMENT	20
11.10. LUBRICATION	21
11.11. VARIATIONS	22
12. CE DECLARATION OF CONFORMITY	23
13. REVISION RECORD	24
14. SERVICE – REPAIR LOG	25
15. APPENDIX	26



## 1. SAFETY INFORMATION



### SAFETY NOTICE:

---

Vehicle Control Barriers are designed to control the flow of Motor Vehicles and Motor Cyclists. It is dangerous to permit pedestrians, cyclists and equestrians to pass and travel through the Traffic Barrier when it is in motion.

It is recommended that easy alternative routes are provided for non-vehicular traffic and that suitable warning and direction signs are placed on either side of the Traffic Barrier.

---



### IMPORTANT NOTE:

---

Only competent and skilled personnel should carry out procedures detailed in this manual.

---



## 2. TECHNICAL DATA

Construction	Steel Frame Aluminium Arm
Span(s)	2000mm to 8500mm (without Curtain) 2000mm to 7500mm (with PVC Curtain)
Operation Movement	90° (Horizontal to Vertical)
Handing	R.H. or L.H. (Optional)
Weight	up to 250 Kg
Balance Weights	16 Kg
Dimensions	Pedestal 450mm x 450mm x 1100mm
Finish	Main Frame - Red <i>(Corporate colours upon request)</i> Pole Arm - Red & White
Optional Accessories	PVC Curtain (half height only) Stop Signs Basic Tip Support Lockable Tip Support



## 3. GENERAL SAFETY STANDARDS



### **SAFETY WARNING:**

---

Before attempting to install and maintain the Newgate Manual Rising Arm Barrier, it is important that the following notes are read and understood. Competent and skilled persons should always carry out any work. Keep these instructions for future use.

---



### **IMPORTANT NOTE:**

---

The Traffic Barrier is essentially a barrier designed for entry/exit for motorised vehicles and is NOT DESIGNED for Pedestrian use. Any other usage will be deemed improper and dangerous. Therefore, it is recommended that suitable signage is erected warning pedestrians not to walk under the Traffic Barrier and separate access is provided for pedestrians.

The traffic barrier is fundamentally a manually driven arm, rising and falling across an access route, and whilst every precaution is taken to make the equipment as functionally as safe as possible, both operators and users should take sensible precautions not to abuse such a traffic control system. To this end, the barrier arm is fitted with a “Fracture Segment” to minimise any vehicular damage in the event of an accidental impact.

It is also strongly recommended that a Maintenance Contract be taken out to ensure that the hinge mechanism, mounted pins and barrier foundation bolts are operating correctly and secure.

Newgate (Newark) Ltd does not accept any responsibility for injury or damage if the Rising Arm Barrier has not been secured or is operated incorrectly.

Employers have a responsibility under Sect 2 of the Health and Safety at Work Act 1974 to ensure as is reasonably practicable the health and safety of employees and other persons who may be affected by work activities. The Management of Health and Safety at Work Regulations 1999 further imposes a specific duty upon employers to carry out suitable and sufficient Risk Assessment of all risks to health and safety of employees and others. Therefore it is recommended a Risk Assessment be carried out by a competent person in accordance with Regulation 3 (l) Management of Health and Safety at Work Regulations 1999.

---



## 4. GENERAL DESCRIPTION

### 4.1. BASIC DESIGN

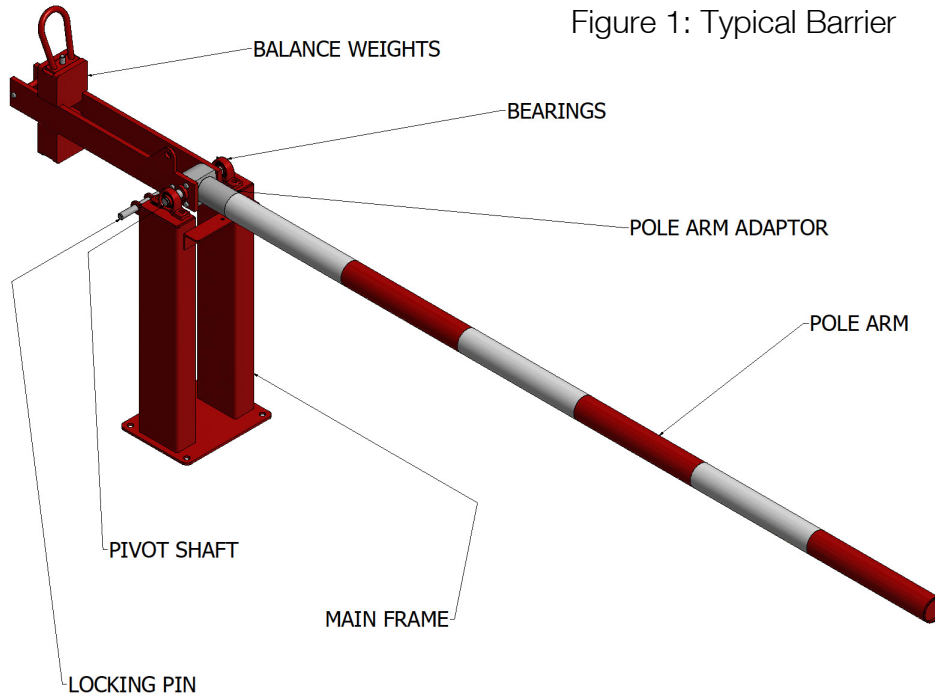

The manual rising arm barrier provides a simple means of manually controlling vehicular access into, or out of industrial premises, car parks, loading bays etc. The barrier is essentially a counterbalanced, lightweight aluminium arm pivoted on a rigid welded steel pedestal. For retaining purposes a locking pin is provided which engages the

balance weight arm in both the horizontal and vertical attitudes. This locking pin is provided with a padlock for additional security and it is incumbent on the client/owner to ensure that the Newgate Manual Rising Arm Barrier is secured in either the vertical or horizontal position.



#### IMPORTANT NOTE:

For manual installation the balance weights are pre-set to allow the arm to move gently, without undue effort.



#### SAFETY WARNING:

Failure to secure the Rising Arm Barrier could result in a serious injury to personnel, or damage to property. It is possible in adverse weather; especially windy weather, that the Rising Arm Barrier will move if the Barrier is not secured.



## 5. HANDLING

### 5.1. TRANSPORTING

For transportation purposes, Newgate manual barriers are always despatched with the pole removed and the pedestal supplied with its balance weight arms locked in the vertical position, for maximum stability.

No specialised equipment is necessary for the lifting and transportation of a barrier other than an overhead lifting device, i.e. small crane, block and tackle or forklift truck, and also a simple two wheel sack truck, or similar.

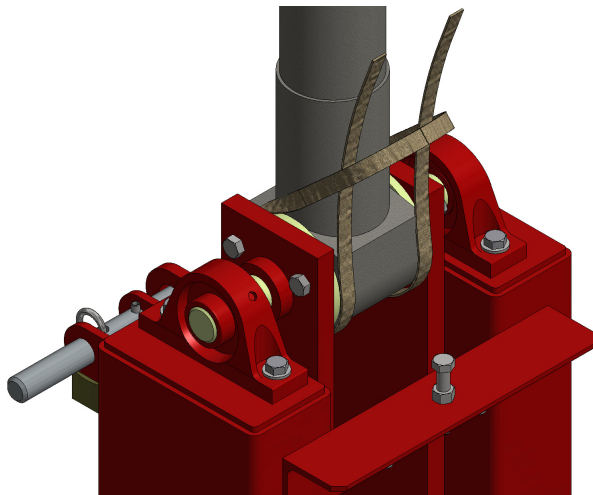

Figure 2B: Lifting

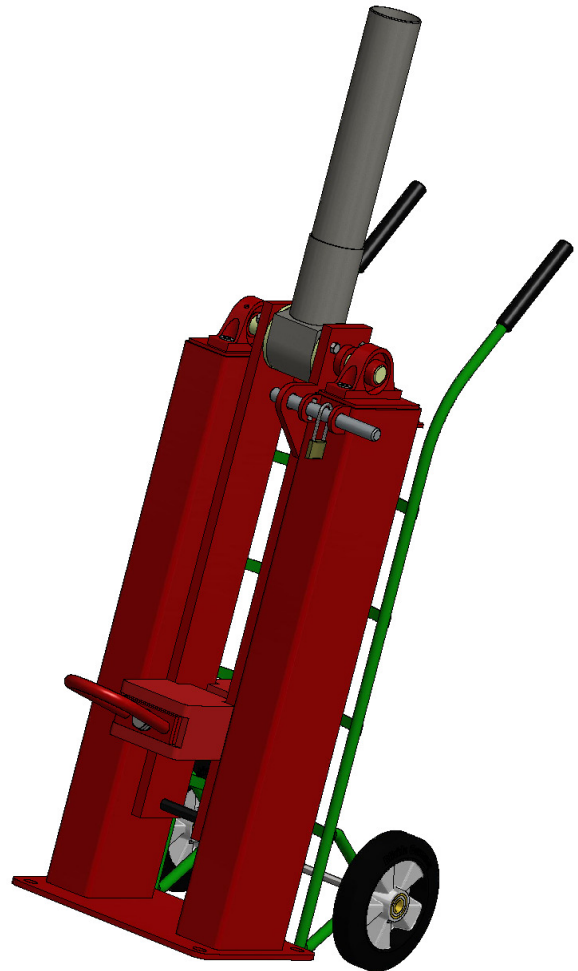

Figure 2A: Transporting

### 5.2. LIFTING

For offloading purposes, it is recommended that nylon slings be attached to the top pivot shaft between the bearings and lowered from the delivery vehicle to the ground by whatever suitable appliance is available i.e. fork lift truck or crane. Movement to the desired location can then be made simply by using a basic two-wheeled sack truck located underneath the base plate.



## 6. INSTALLATION

### 6.1. FOUNDATIONS

If details of the base have not been specified, we recommend a concrete mix to BS EN 206-1:2000 “Concrete specification, Performance, Production and Conformity” to type C32/40, which is equally suitable for external and internal environments. Alternative types of base construction may be acceptable, subject to discussions with our Contract Engineering Department. It is **not** necessary to pre-drill the base to receive the equipment; the drilling is carried out when the equipment is erected. We recommend a minimum of 7 to 10 days for the concrete to cure, depending on climate. This time can be reduced if additive agents are used.

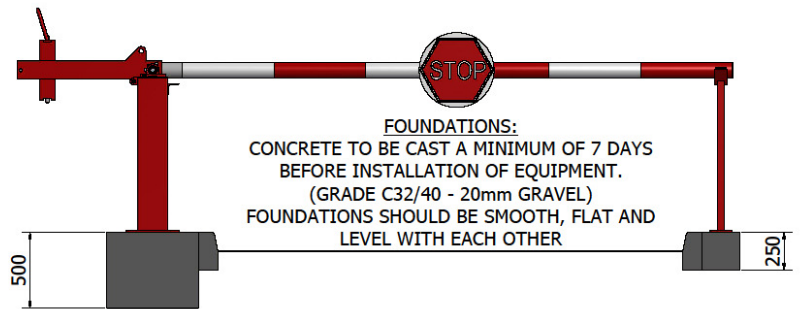
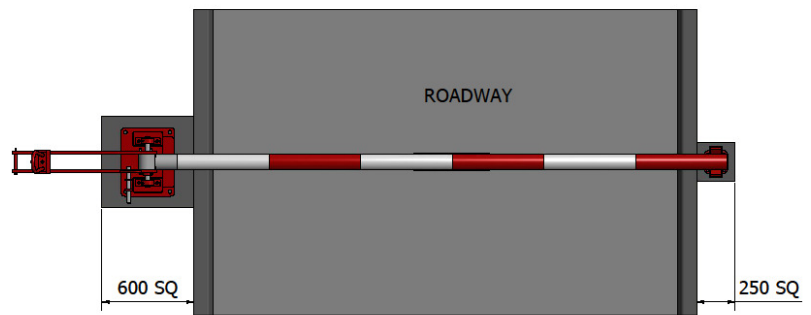

Figure 3 - Foundation Detail



#### IMPORTANT NOTE:

Where a tip support is required or if two barrier arms are to meet in the centre of the road, then **both** bases must be at the same level.

When ancillary equipment requires post mounting, (example: card reader, intercom, keypad etc.) the notes above can be applied. Drawings showing recommended positions of the equipment and foundation requirements can be supplied with the relevant data sheets.

Careful consideration should be made when deciding the location of the barrier to avoid overhead obstructions such as power cables, telephone cables, building canopies, trees and similar likely constructions, so as not to restrict the barrier arm in the vertical position.

Accessibility around the whole of the barrier pedestal should be maintained to a minimum of 1000mm to allow sufficient room for installation, subsequent maintenance and hand-wind operation.



#### IMPORTANT NOTE:

Newgate should be consulted immediately should any possible restrictions occur





## 6.2. BARRIER

It is preferable that installation takes place when expected through traffic is at a minimum. Position the barrier pedestal, still in its vertical position, onto its prepared concrete base. The locking pin should be at the rear and the stop bracket at the front (facing the road).

Approximately align the pedestal, so that its centre line is in the position across the road where it is anticipated the pole will be when in the down position.

Using a 20mm heavy duty masonry bit in a suitable percussion drill, drill through one of the front (road side) holes in the base plate to a minimum depth of 180mm taking care to keep the holes free of excessive dust. A 20mm x 160mm long expansion bolt can now be hammered into the prepared hole, (keeping the nuts in the highest possible position). Tighten down the single nut so that the barrier is firmly fixed.

Remove the padlock and withdraw the locking pin and raise the balance weight assembly until it is horizontal and re-insert the locking pin. The pole can now be slid onto the pole adaptor and secured with the fixing bolts. With the pole now mounted, a check can be made regarding the alignment of the barrier across the road and adjustment made as required.



### **SAFETY WARNING:**

---

It is strongly recommended, particularly on longer span barriers, to seek assistance in this operation due to the weight been lifted. The balance weights weigh 16kg therefore, in some cases it is advisable to remove the counter balance weights before fitting the pole. Once the pole has been fitted the weights can be reassembled.

---

Complete the bolting down operation by drilling the three remaining foundation holes and bolting down as previously described.

Before tightening up the nuts, check that the barrier is vertical, packing as necessary. Tighten down all four (4) foundation bolts. Cut or Grind off the surplus thread from the bolts for a neat finish and cap the nut. If levelling is necessary between the base and foundation ensure any gaps are grouted in using either Chemifix or Standard Cement.

If a tip support is being installed, this can now be positioned, using the pole as a positional reference, and bolted down in a similar manner using 12mm x 150mm expansion bolts.

If a strainer wire assembly kit is provided, this should now be bolted on and tensioned to remove any visible "sag" of the barrier arm.



### **IMPORTANT NOTE:**

---

Always wear safety goggles/ visors when drilling/ hammering into concrete.

---



## 7. MECHANICAL ADJUSTMENTS

### 7.1. BALANCE WEIGHT ADJUSTMENT

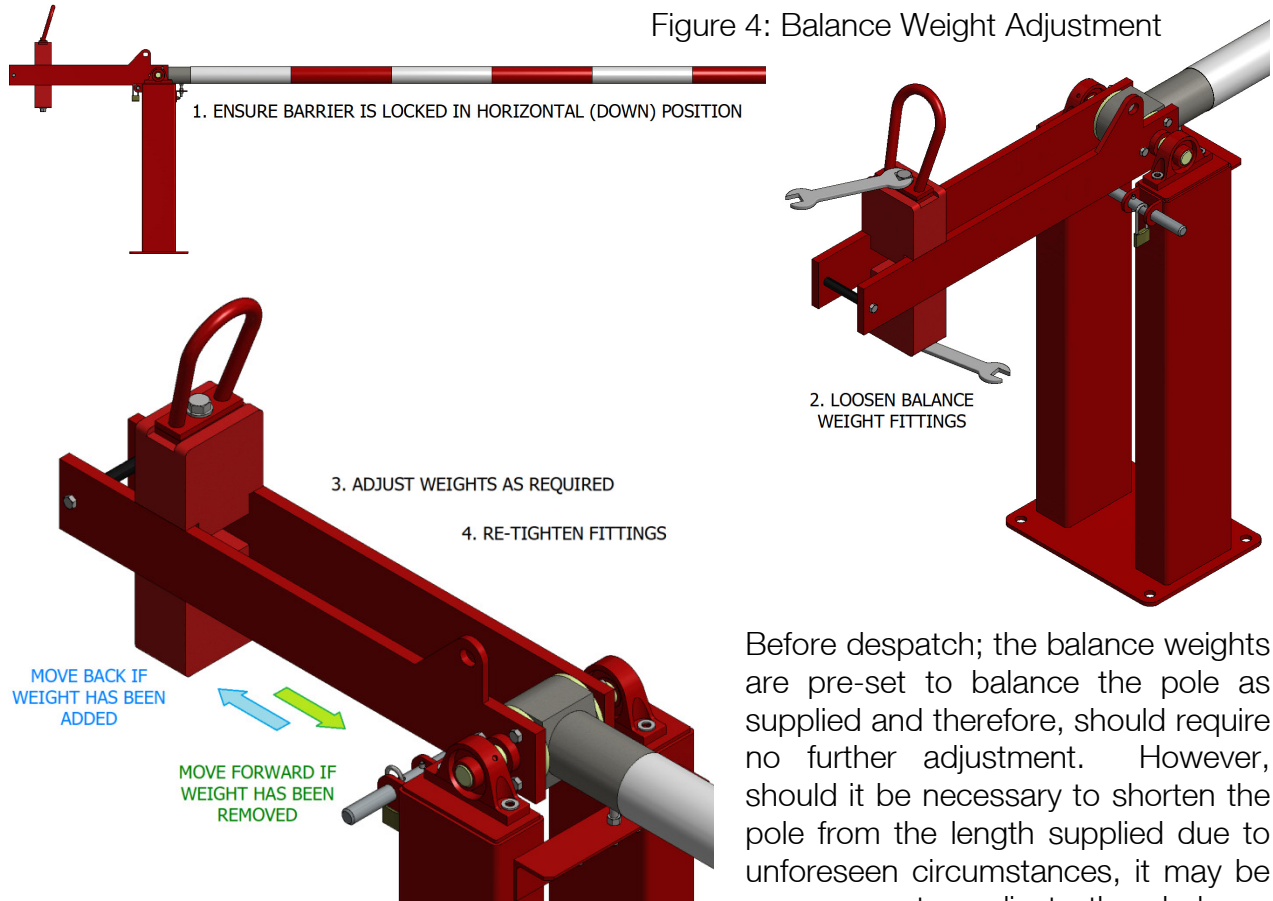

Before despatch; the balance weights are pre-set to balance the pole as supplied and therefore, should require no further adjustment. However, should it be necessary to shorten the pole from the length supplied due to unforeseen circumstances, it may be necessary to adjust the balance weights accordingly.

This can be achieved by slackening the tie bolt nuts holding the balance weights in position and carefully tapping the weights in or out as required, so that balance is achieved just sufficient to prevent the arm lifting on its own. Care should always to be taken when handling these weights.



#### IMPORTANT NOTE:

This operation should only be carried out with the barrier restricted in its horizontal position.



7.2. STOP SCREW ADJUSTMENT

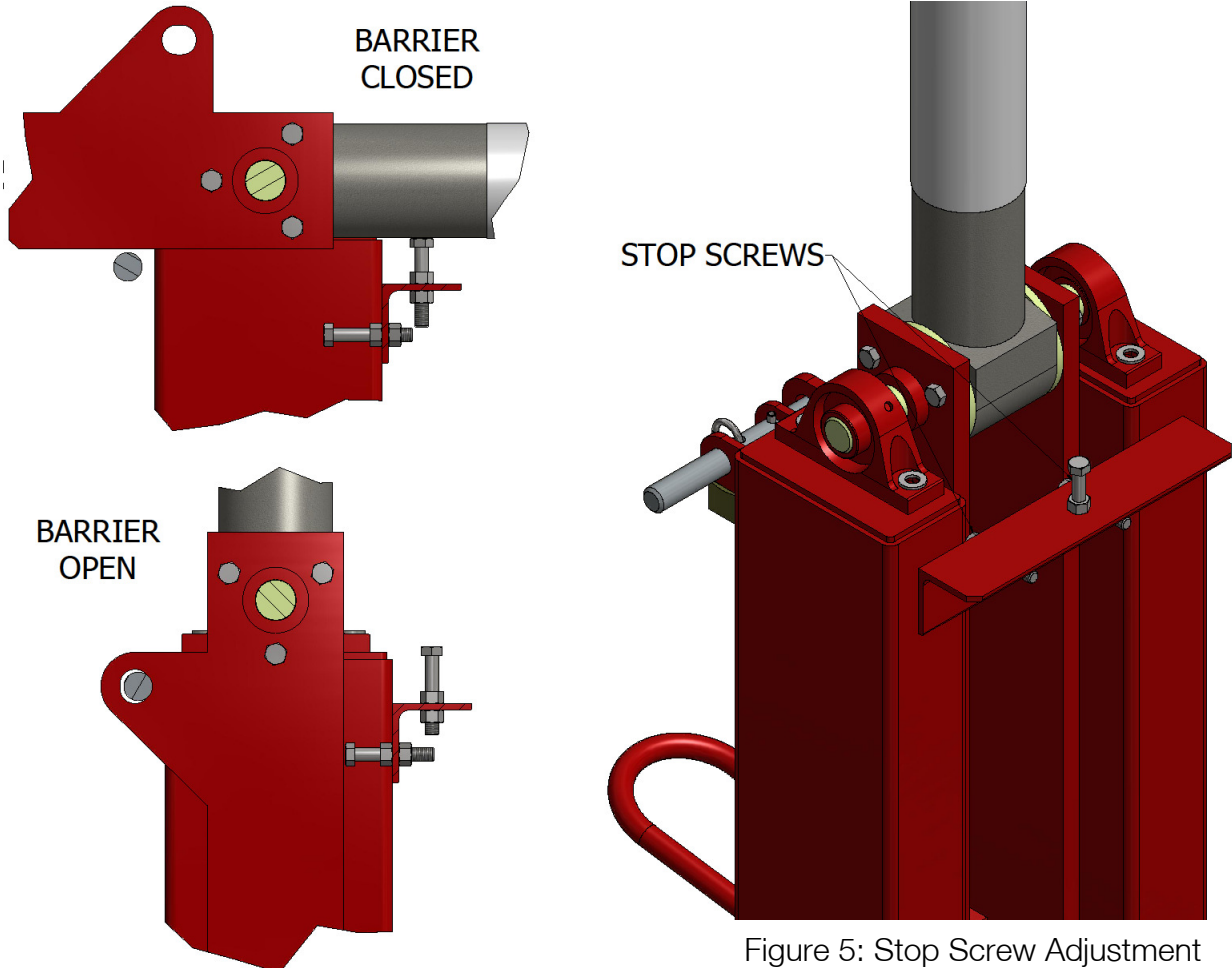

Figure 5: Stop Screw Adjustment

Due to site variations and pole deflection, it may be necessary to adjust the pole arm stop screws, situated underneath the pole adaptor.

To adjust screws; move and secure barrier to horizontal/ vertical position (removing weight from the stop screw to be adjusted). Slacken off the two locknuts holding the screw using two suitable spanners, adjust the screw as required and re-tighten the locknuts. Once secured again, test the barrier position and repeat process if necessary.



## 8. COMMISSIONING

It is preferable that both the installation and commissioning take place when expected through traffic is at a minimum to avoid disruption.



**SAFETY NOTICE:**

---

**DO NOT** place your hands/ fingers inside the barrier when the operating.

---



9. OPERATION

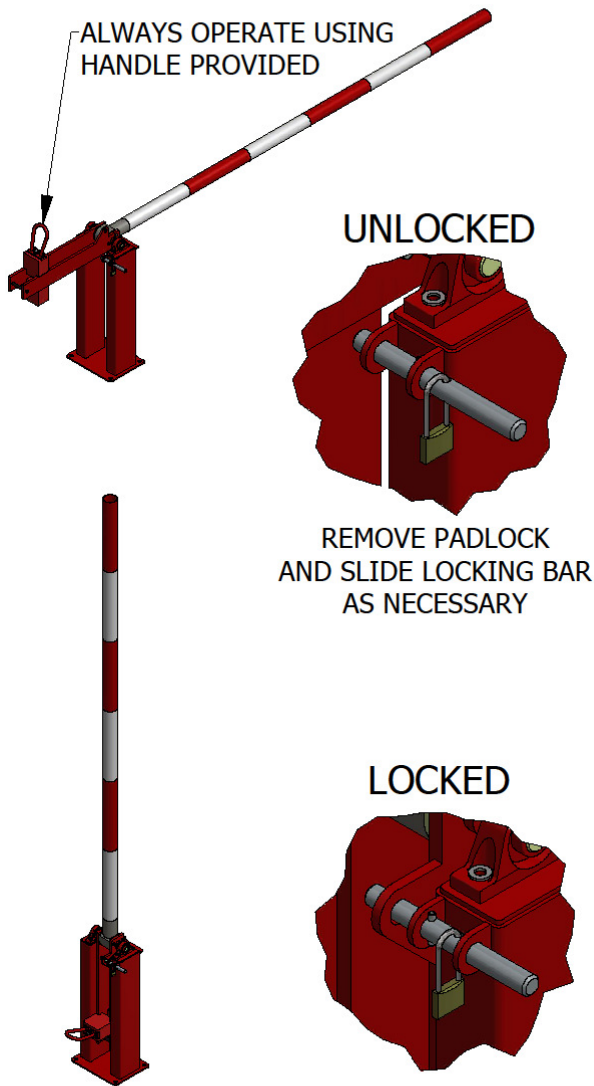

Figure 6: Operation

Correct operation of the Newgate manual rising arm barrier should be as follows:

- a) Ensure barrier is clear of all obstructions.
- b) Remove padlock from the locking bar and slide outwards so it does not impede the barrier.
- c) Keeping your body behind the barrier and both hands firmly gripping the handle provided, push down the barrier until the pole arm is vertical.
- d) Keeping one hand on the barrier handle to ensure the pole arm does not drop, slide over the locking bar so that it inserts into the lug hole on the pole arm.
- e) Re-insert the padlock and lock to secure the barrier in place.
- f) To lower barrier; the procedure should be the same but take care to hold the handle whilst removing the locking bar as a knock could cause the barrier to drop freely; likely causing damage to the barrier and possibly harming its operator.



10. MANUAL TRAFFIC BARRIER – GENERAL ASSEMBLY

10.1. MANUAL TRAFFIC BARRIER – EXPLODED DIAGRAMS

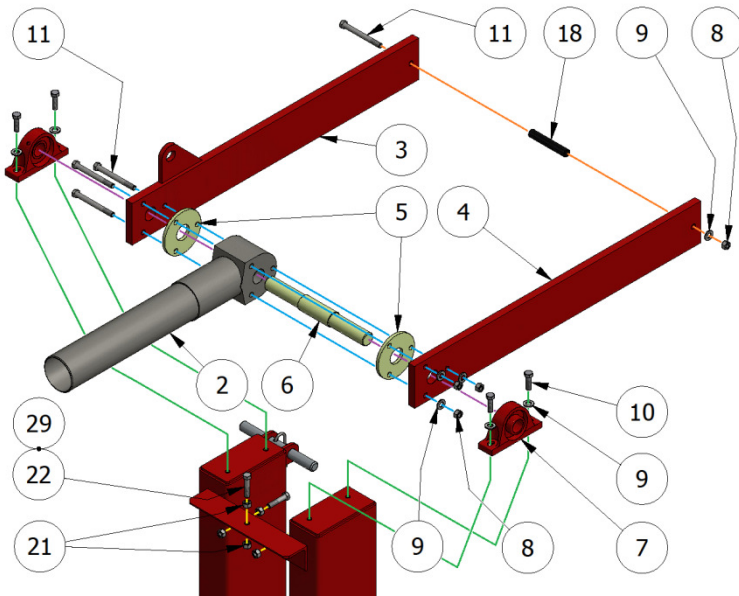
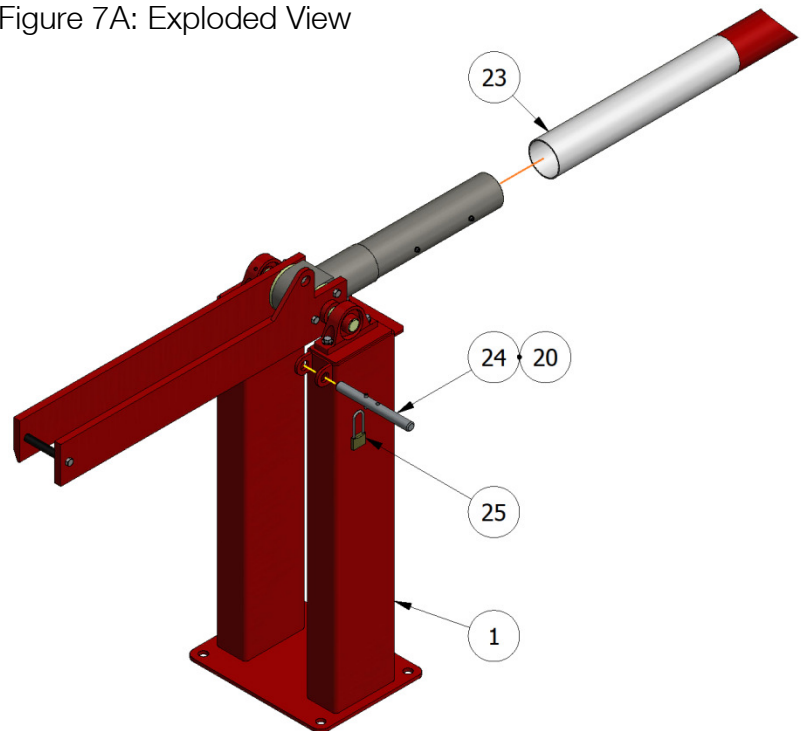

Figure 7A: Exploded View



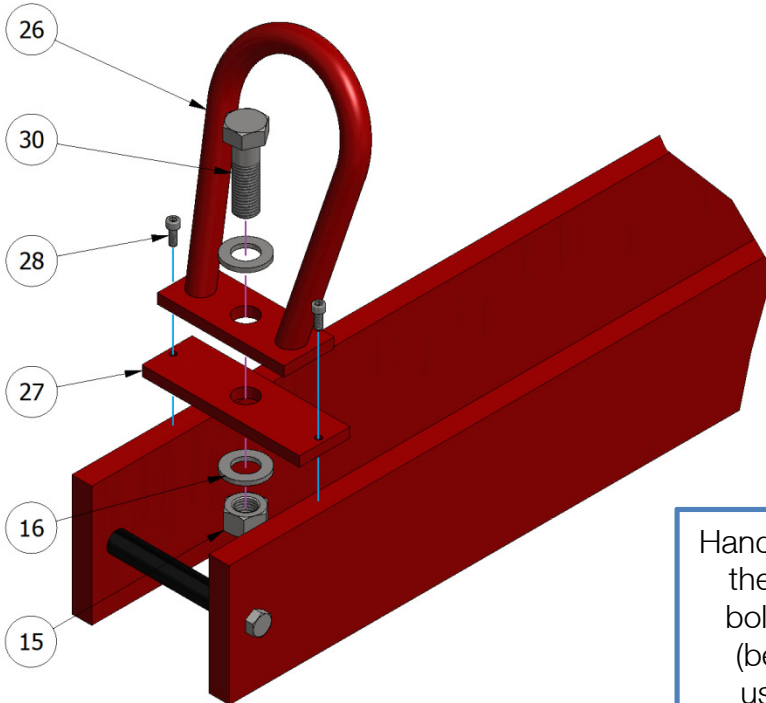
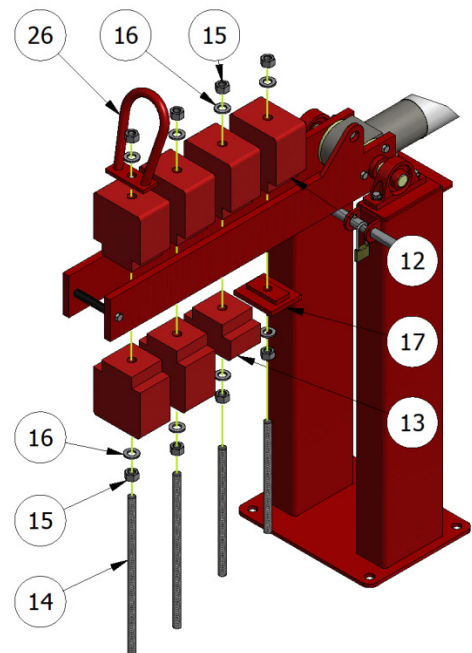

Figure 7B: Exploded View

Handle position will vary according to the weight assembly fitted; either bolted through with fitted weights (below), or when no weights are used; fitted to a mounting plate which is bolted directly to back plates (left).

Various types of balance weights are shown here for reference – number of weights will be fitted to suit individual barriers



10.2. MANUAL TRAFFIC BARRIER – SPARE PARTS

Item	Description	Part Number (3" Pole)	Part Number (4" Pole)
01	Main frame	305/02/10161	305/02/10161
02	Pole arm adaptor	652/03/10088	655/03/10162
03	Back plate (with Lug)	405/03/10167	405/03/10165
04	Back plate (without Lug)	405/03/10166	405/03/10164
05	Spacer	605/03/10168	Not Used
06	Pivot shaft	605/03/10169	605/03/10169
07	Bearing	550/04/10330	550/04/10330
08	M12 Nyloc nut	914/00/12000	914/00/12000
09	M12 Round Washer	915/00/12000	915/00/12000
10	M12 x 40 Hex Hd. bolt	910/00/12040	910/00/12040
11	M12 x 150/160 Hex Hd. bolt	910/00/12150	910/00/12160
12	Balance weight (Full)	805/03/10170/00	805/03/10170/00
13	Balance weight (Half)	805/03/10170/01	805/03/10170/01
14	M20 Screwed rod	918/30/03000	918/30/03000
15	M20 Nyloc nut	914/00/20000	914/00/20000
16	M20 Washer	915/00/20000	915/00/20000
17	Blank make up piece	305/03/10173	305/03/10173
18	Spacer tube	605/03/10174	605/03/10174
19	Roll pin (Stainless steel)	941/00/03024	941/00/03024
20	Roll pin	941/04/08040	941/04/08040
21	M12 Hex nut	912/00/12000	912/00/12000
22	M12 x 55 Hex screw	911/00/12055	911/00/12055
23	Pole arm	984/30/00000/000	984/30/00000/000
24	Locking pin	605/03/10175	605/03/10175
25	Padlock	000/-/00000/049	000/-/00000/049
26	Manual handle	305/03/24228	305/03/24228
27	Handle mounting plate	405/03/24810	405/03/24810
28	M6 x 16 Skt. Cap screw	919/00/06016	919/00/06016
29	Ferrule Ø18 Type 'D'	803/04/22912	Not Used
30	M20 x 65 Hex Hd. bolt	910/00/20065	910/00/20065





## 11. MAINTENANCE

### 11.1. BEFORE CARRYING OUT MAINTENANCE

The following must all be completed before starting maintenance of gate;

- i. Obtain a Work Permit.
- ii. Area to be cordoned off (using warning signs).
- iii. Complete Risk Assessment for maintenance task (for example risk assessment see 13. Risk Assessment (Example))

### 11.2. WHILST CARRYING OUT MAINTENANCE

The following must all be adhered to whilst carrying out maintenance of gate;

- i. The site Health & Safety Rules and Regulations are to be adhered to and observed at all times.
- ii. Personal Protective Equipment is to be worn at all times whilst on site (i.e. Hi-Vis clothing, safety boots, safety glasses, ear defenders, gloves etc.)

### 11.3. AFTER CARRYING OUT MAINTENANCE

The following must all be completed after completing maintenance of gate;

- i. Remove cordoned off area.
- ii. Depart the site leaving the area clean and tidy.

### 11.4. ORDERING SPARE PARTS

#### **SAFETY WARNING:**



By using non-genuine Newgate parts you are potentially compromising the machine, causing risk to all those using the barrier.

Spare parts can be obtained by contacting Newgate parts department, for typical spare parts see '12.7 Spare Parts'.

### 11.5. SERVICE SCHEDULE

COMPONENT	MAINTENANCE TASK	TIME PERIOD			
		DAILY	WEEKLY	MONTHLY	YEARLY
All	Clean and Paint (where rusted)				✓
Boom lights & Stop Signs	Check Condition				✓
Holding-Down Bolts	Check Tightness				✓
Bearings	Check for Wear & Lubricate				✓
Balance weights	Check and tighten				✓



11.6. REPLACING POLE ARMS

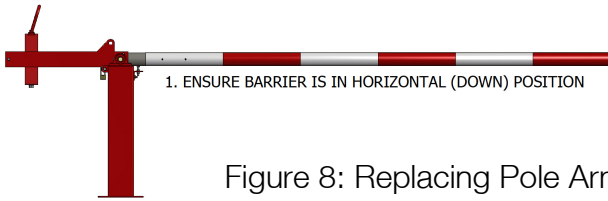
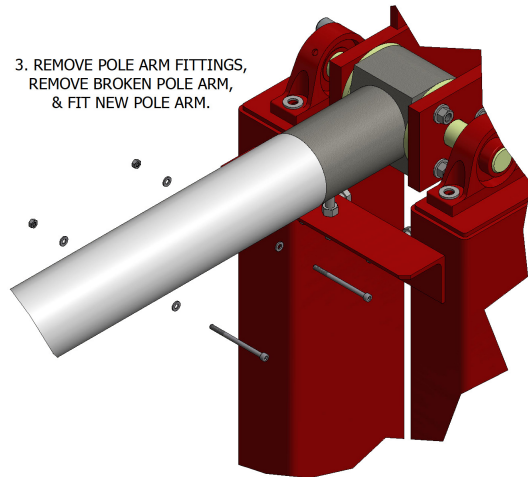
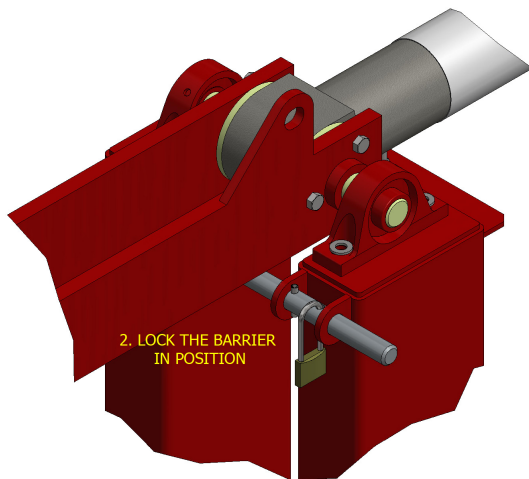

Figure 8: Replacing Pole Arms

In the event that the barrier pole suffers damage due to inadvertent impact from a vehicle, it is relatively a simple to replace the pole, as follows: -



4. Once the pole arm has been fitted; the balance weights should be adjusted (if necessary), and the barrier then returned to normal operation.



11.7. REPLACING POLE ARM ADAPTORS

In the event that vehicular impact damage is more severe, resulting in a broken pole adaptor casting, this will obviously have to be replaced. The procedure is as follows: -

Figure 9: Replacing Pole Arm Adaptors

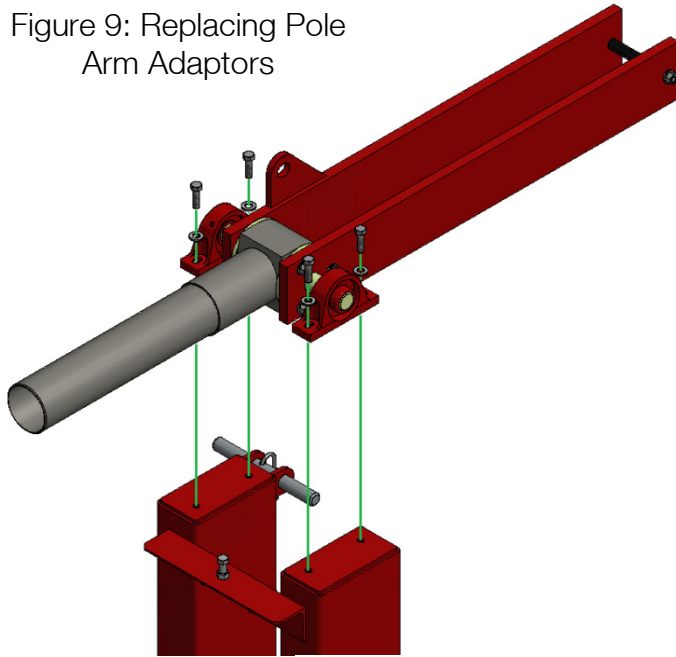

- a) Lock barrier in horizontal position.
- b) Remove Strainer wire (if fitted).
- c) Carefully remove balance weights.
- d) Remove pole arm (see 11.6).
- e) Remove the whole counter balance assembly (complete) by removing the pivot bearing fixing-bolts.
- f) Some bearings may have 3mm roll pins (older barriers); these will need to be knocked through using a small punch.
- g) Remove the whole counter balance assembly from its pedestal and stand upright on a firm surface, pole adaptor and pivot uppermost.

- h) Remove the Plummer block bearings.
- i) Remove the three M12 bolts clamping the pole adaptor boss in place and the one on the end of the back plates.
- j) Remove the broken boss, (together with the two spacers if a 76mm pole assembly).
- k) Knock out the shaft.
- l) Re-fitting of a new pole adaptor is in reverse sequence to the above, but replacing the shaft in position before tightening the three M12 clamping bolts.

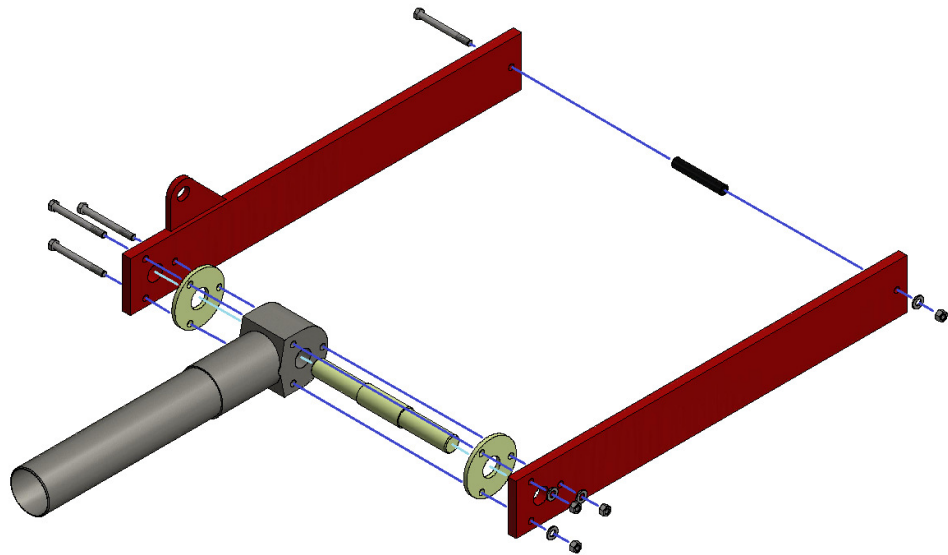

## 11.8. METHOD STATEMENT

### MAINTENANCE OF A MANUAL RISING ARM BARRIER

1. On arrive on site report Works Engineer/Security/Reception for Induction/Briefing.
2. Obtain a Work Permit.
3. Cordon off area off. (using Warning Signs)
4. Wear Personal Protective Equipment as and when required. ( Hard Hat, Safety Glasses, High Vis Jackets, Gloves , Safety Boots)
5. Check for damage.
6. Check Mounting bolts to the pedestal frame.
7. Check the Tip Support Frame for damage.
8. If Fitted check the strainer wire for tension
9. Check the Counter Balance Weights are secure.
10. Check the Pivot Shaft and bearings.
11. Check the Locking Mechanism
12. Wipe down and clean the Manual Barrier
13. Test
14. Remove cordoned off area
15. Inform client on completion, test and demonstrate if required.
16. Depart the site leaving the area clean and tidy.



## 11.9. RISK ASSESSMENT

### MAINTENANCE OF A MANUAL RISING ARM BARRIER

#### HAZARDS WHICH CAN BE FORESEEN:

1. Tripping hazards eg cables, extension leads, stored materials on site
2. Injuries due to lifting heavy objects.
3. Contact with hazardous substances
4. Oncoming vehicular traffic
5. Other Contractors working nearby.
6. Pedestrians
7. Hand entrapment.

#### CONTROLS IN PLACE TO MINIMISE THE RISK:

1. Operators trained and conversant with the mechanics of the barrier operating system.
2. Correct Manual Handling Training techniques to be adhered to at all times.
3. Care is to be exercised to reduce tripping hazards, e.g. removing such hazards away from the working area.
4. Working area to be cordoned off prior to commencing work.
5. Operators to wear Hi Vis Coats/Waistcoats/Waterproofs.
6. PPE to be worn as and when required and in line with Newgate (Newark) Ltd Policy. . (Hard Hat, Safety Glasses, High Vis Jackets, Gloves, Safety Boots)
7. COSHH Regulations to be observed at all times.
8. Operatives are to be made aware of the clients Health and Safety Procedure and Emergency Action Plan.
9. Cuts. All vehicle carry First Aid kits.
10. Fire. All vehicles carry Fire Extinguishers



## 11.10. LUBRICATION

The only moving component on a Newgate Manual Rising Arm Barrier is the pivot shaft and bearings. The bearings are “Sealed for Life” Plummer Blocks however, it is recommended that routine maintenance is carried out throughout the life of the equipment to inspect the Pivot Shaft, Bearings and other components e.g. Barrier Pole, Balance Weights and Plinth Bolts

For further assistance, our Technical Department (Tel: 01636 700172) or Services Department (Tel: 01636 704000) should be consulted.



### 11.11. VARIATIONS

The Newgate manual rising arm barrier is also ideal for sequentially controlling vehicular traffic in hazardous areas, such as tanker loading bays, whereby certain operations have to take place in a predetermined and interlocked sequence. For this type of application, a special dead bolt is incorporated to replace the normal padlock, engaging in a modified locking pin, together with a modified backplate, which only allows the barrier to be fully locked, and permit key removal in the lowered position.

The type of lock fitted for this purpose is “Fortress Interlock” model H 31Q or H31Q2, (single or double key unit) or a castell K6.35.

The locking bar is modified to replace the padlock hole with a notch, to be engaged by the interlock, the bar is also spring loaded. This means that the barrier can only be restrained in the raised position but cannot be locked; to engage the locking one must release the interlock using a special key that may only be removed once the interlock has locked the bar again.

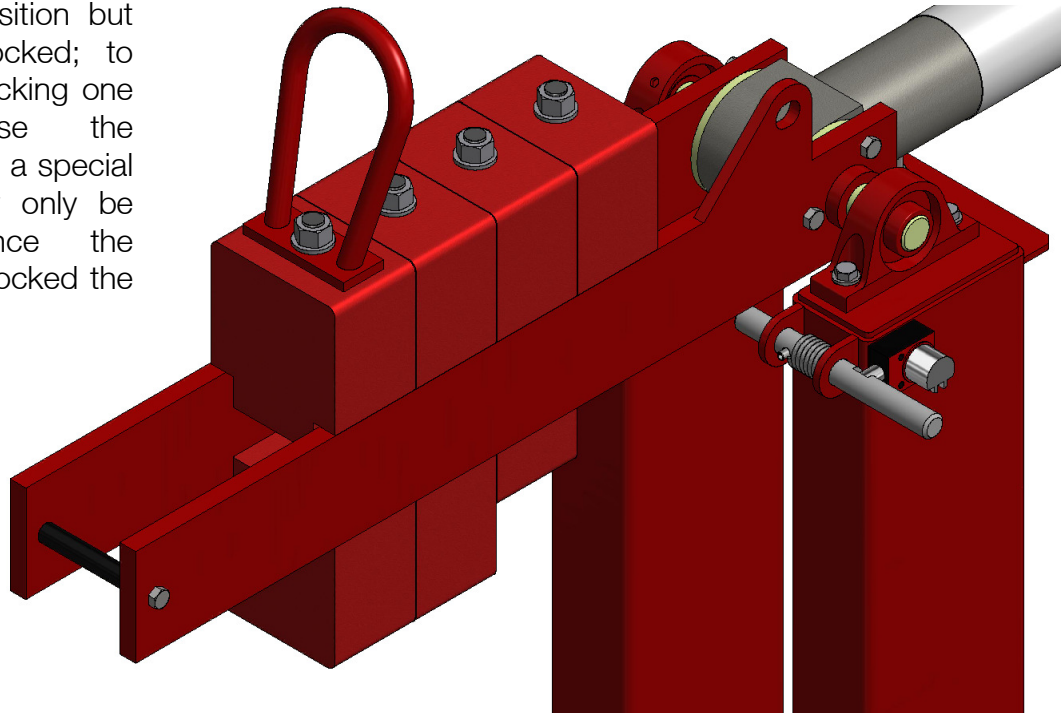

Figure 10: Deadlock Interlocks

## 12. EC DECLARATION OF CONFORMITY



Tel: 01636 700172 / 704000  
e-mail: [sales@newgate.uk.com](mailto:sales@newgate.uk.com)

Fax: 01636 605400 / 605957  
URL: [www.newgate.uk.com](http://www.newgate.uk.com)

### HEALTH AND SAFETY COMPLIANCE CERTIFICATE

**1. BUSINESS NAME & ADDRESS OF RESPONSIBLE PERSON:**

Newgate (Newark Ltd)  
Brunel Drive  
Newark  
Nottinghamshire  
NG24 2DE

**2. CAPACITY/ROLE OF RESPONSIBLE PERSON:**

Manufacturer

**3(i) DESCRIPTION OF MACHINE:**

Manual Rising Arm Traffic Barrier.

**3(ii) Model Number:-** Manual Rising Arm Traffic Barrier.

**3(iii) Serial Number:-**

**4. RELEVANT EC DIRECTIVES & REGULATIONS COMPLIED WITH FOR ABOVE MACHINE.**

Machinery Directive 2006/42/EC: The Supply of Machinery (Safety) Regulations 2008. (A full list of supporting standards available on request)

**5 (i) RELEVANT EC TRANSPOSED HARMONISED STANDARDS**

**5(ii) NATIONAL STANDARDS USED**

BS 6571 Pt 1 - 1989

**6 DECLARATION:**

I certify that on completion of manufacture of the machine detailed in (3) above that a full conformity assessment has been completed and relevant essential Health & Safety requirements complied with.

**Name:** Alan Osgerby Kevin Smith

**Status within Company:** Joint Managing Directors



**Signatures:**

Company Registration No: 1870156

VAT: 416 1521 86

Member of: Constructionline, Safec Contractor, CHAS

OCD 04



13. REVISION RECORD

Rev. No.	Revision Description	Date
1.0	Original Issue	30-08-13





# INSTALLATION, COMMISSIONING AND MAINTENANCE

## 14. SERVICE – REPAIR LOG

DATE	REPAIR No.	SERVICE	NEXT DUE
01-01-2010	123456	Annual Service	01-01-2011



15. APPENDIX 1

