



LOCAL AREA NETWORKS (LAN)



SERVERS



DATA CENTERS



INDUSTRIAL PLCS



ELECTRO-MEDICAL DEVICES



EMERGENCY DEVICES (Lights/Alarms)



TELECOMMUNICATION DEVICES



E-BUSINESS (Servers Farms, ISP/ASP/POP)



INDUSTRIAL PROCESSES

# Master Plus

## 100-800 kVA three-phase/three-phase

Master Plus 100-800 kVA



Dimensions (mm)

MP 100 - MP 120  
MP 160 - MP 200

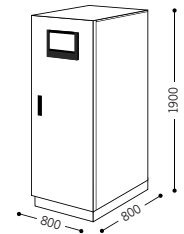

12 MP 100

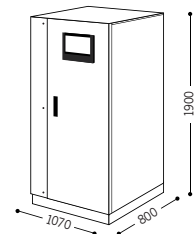

12 MP 120 - 12 MP 160  
12 MP 200

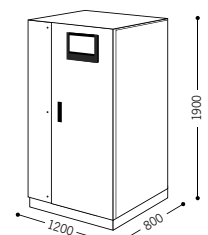

### ABSOLUTE PROTECTION

**Master Plus** is an on-line double conversion UPS (VFI SS 111 in accordance with IEC EN 62040-3) with a transformer isolated inverter. **Master Plus** has a compact foot print and high quality output to provide the ultimate power protection for "mission critical" applications: data processing, tele-communications, industrial processes, security and electro-medical systems.

## EASY SOURCE

**Master Plus** technology removes the problems of over sizing upstream power sources, whilst improving load power factors and current harmonics.

The UPS features the latest input current absorption techniques including progressive rectifier start-up and the option to reduce battery charging currents.

These features make **Master Plus** one of the most generator compatible and environmentally friendly UPS available.

## BATTERY CARE SYSTEM: MAXIMUM LIFETIME POTENTIAL

Traditionally, when a mains supply is present the UPS charges its batteries. Battery power is used for the inverter should the input supply fail. Efficient battery management and care is therefore essential to the overall performance of the UPS in an emergency.

The Master Plus Battery Care System consists of a range of features designed to provide optimum performance and enhanced operating life:

- Dual level charging regime to optimise recharge currents and lower recharge times
- Temperature compensation and deep discharge protection to reduce overall battery aging
- Charge blocking system to reduce electrolyte consumption and lengthen the life of VRLA batteries
- Predictive battery testing to spot potential battery deterioration and failure

Master Plus is also compatible with different battery technologies: open-vented lead acid and AGM and Gel VRLA, NiCd.

## MAXIMUM RELIABILITY AND AVAILABILITY

Connect up to 8 units in parallel or N+1 redundancy, even of different power ratings. The UPS continue to operate in parallel even if one of the interconnecting communication cables is disconnected (closed loop).

## FLEXIBILITY

Master Plus is suitable for a wide range of applications including IT and the most demanding industrial environments. The UPS is suitable for power capacitive loads such as blade servers, without any reduction in active power, from 0.8 to 0.9 lagging. With a broad range of accessories and options, complex configurations and system architectures can be achieved to guarantee maximum power availability and the option to add new UPS without interruption to existing users. Using the Riello UPS Group Synchroniser (UGS) and Parallel Systems Joiner (PSJ) sophisticated inter group parallel and redundant systems can be achieved to provide the highest possible levels of resilience and availability.

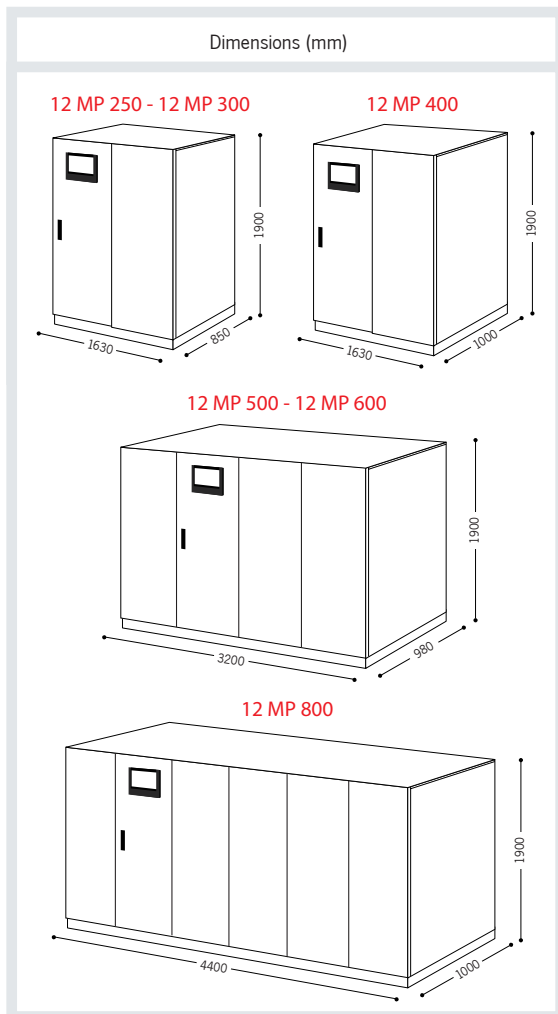
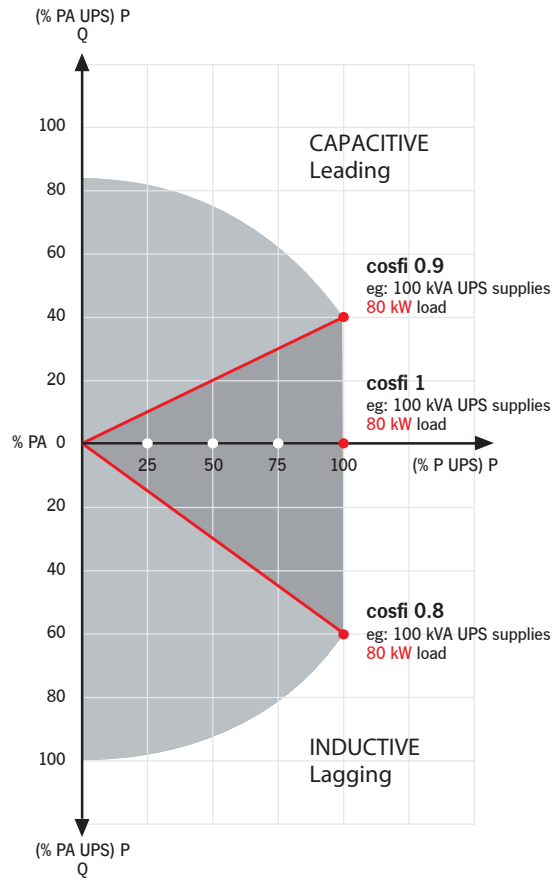

**OPTIONS**

• **UGS - UPS Group Synchroniser**

Allows 2 or more UPS not in parallel to remain synchronised even during a power failure.

The UGS also enables a RIELLO UPS to be synchronised with an independent power source, even of a different power rating.

• **PSJ - Parallel Systems Joiner**

Connects two UPS groups operating in parallel configurations through a power coupling switch.

The Slave UPS Group is permanently synchronised to the Master group. Should one of the UPS in one of the parallel groups fail, the PSJ will automatically connect the remaining UPS to the other group via an external bypass

**EASE OF INSTALLATION**

Master Plus is compact with a foot print of only 0.64sqm for a 200kVA system. Front access to internal assemblies and top panel ventilation make space allocation within confined data processing or plant rooms easy. Master Plus can be placed against a wall as there is no requirement for rear or side panel access for maintenance or ventilation.

**SPECIFIC SOLUTIONS**

The UPS can be adapted to your requirements.

Please contact TEC to discuss specific applications and options.

**ADVANCED COMMUNICATION**

- Compatible with TeleNetGuard for remote maintenance
- Advanced, multi-platform communication for all operating systems and network environments: PowerShield<sup>3</sup> monitoring and shut-down software included, with SNMP agent, for Windows 9x, ME, NT 4.0, 2000, XP, Vista and 2003 server; Mac OS X, Linux, Novell and most popular Unix operating systems
- The UPS is supplied with a cable for direct connection to the PC (Plug and Play)
- RS232 double serial port
- Installation slot for an Emergency Power Off (EPO) interface to allow the UPS to be switched off remotely in an emergency.
- Generator interface: enables desynchronisation of the UPS output from a generator supply which may be subject to phase and frequency variations. The interface also enables more economic use of the battery charger.

1. Parallel configuration of up to 8 units with separate batteries

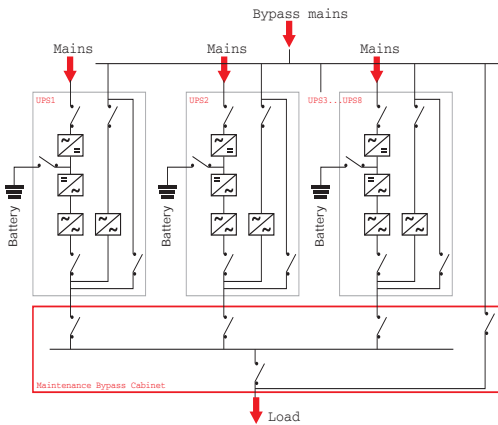

2. Parallel configuration of up to 8 units with a common batteries

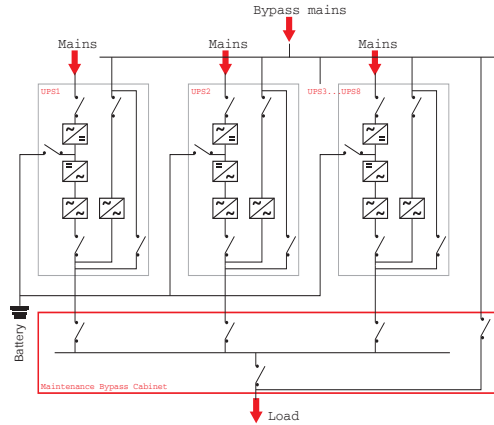

3. Dynamic dual bus configuration

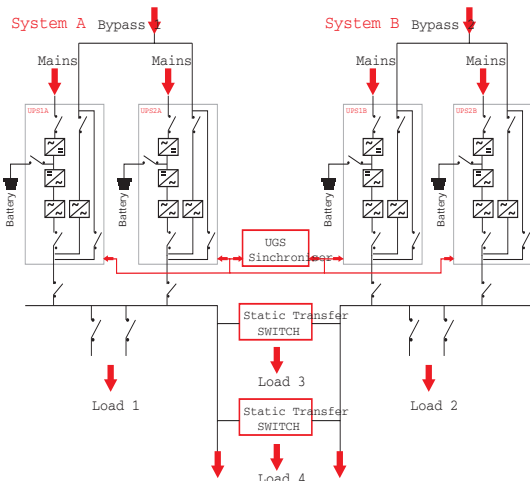

4. Dual bus system configuration

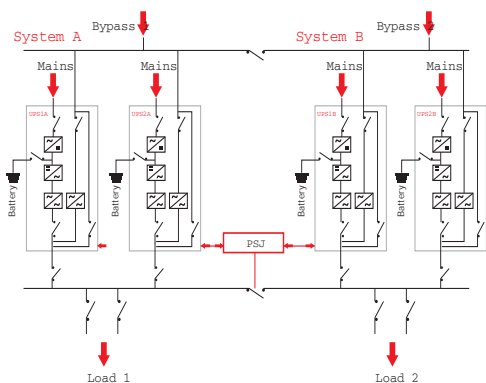

MODELS	MP 100	MP 120	MP 160	MP 200
POWER (kVA)	100	120	160	200
<b>INPUT</b>				
Nominal voltage	380 - 400 - 415 Vac three-phase			
Voltage tolerance	400 V + 20% / - 25%			
Frequency	45 ÷ 65 Hz			
Power factor	> 0.95 in the 12MP HC version			
Current distortion	< 3% in the 12MP HC version			
Soft start	0 ÷ 100% in 30'' (selectable)			
Permitted frequency tolerance	± 2% (selectable from ± 1% to ± 5% from the front panel)			
Standard features	Back Feed protection; separable bypass line			
<b>BATTERIES</b>				
Type	Lead, flooded and VRLA AGM / GEL; NiCd			
AC ripple	< 1%			
Temperature compensation	-0.5 Vx°C			
Typical charging current	0.2 x C10			
<b>OUTPUT</b>				
Rated power (kVA)	100	120	160	200
Active power (kW)	80	96	128	160
Number of phases	3 + N			
Nominal voltage	380 - 400 - 415 Vac three-phase + N			
Static stability	± 1%			
Dynamic stability	± 5% in 10 ms			
Voltage distortion with linear load	< 1%			
Voltage distortion with distorting load	< 3%			
Crest factor (I <sub>peak</sub> /I <sub>rms</sub> )	3:1			
Frequency stability on battery mode	0.05%			
Frequency	50 or 60 Hz (selectable)			
Overload	110% for 60'; 125% for 10'; 150% for 1'			
<b>ENVIRONMENTAL</b>				
Weight (kg)	640	650	770	810
Dimensions (HxLxD) (mm)	1900 x 800 x 800			
Remote signalling	Voltage-free contacts			
Remote commands	EPO and bypass			
Communication	double RS232 + remote contacts + 2 communication interface slots			
Operating temperature	0°C / +40°C			
Relative humidity	< 95% non condensing			
Colour	Light grey RAL 7035			
Noise	63 ÷ 68 dBA at 1 m			
Protection rating	IP20			
Efficiency	Up to 94%			
Standards	Directives EC 73/23 - 93/68 - 2004/108; Safety IEC EN 62040-1; EMC IEC EN 62040-2; Performance IEC EN 62040-3			
Classification as per IEC 62040-3	(Voltage Frequency Independent) VFI - SS - 111			

MODELS	12 MP 250	12 MP 300	12 MP 400	12 MP 500	12 MP 600	12 MP 800
POWER (kVA)	250	300	400	500	600	800
<b>INPUT</b>						
Nominal voltage	380 - 400 - 415 Vac three-phase					
Voltage tolerance	400 V + 20% /- 25%			400 V ± 20%		
Frequency	45 ÷ 65 Hz					
Power factor	> 0.95 in HC version			> 0.93 in HC version		
Current distortion	< 3% in HC version					
Soft start	0 ÷ 100% in 30" (selectable)					
Permitted frequency tolerance	± 2% (selectable from ± 1% to ± 5% from the front panel)					
Standard features	Back Feed protection; separable bypass line					
<b>BATTERIES</b>						
Type	Lead, flooded and VRLA AGM / GEL; NiCd					
AC ripple	< 1%					
Temperature compensation	-0.5 Vx°C					
Typical charging current	0.2 x C10					
<b>OUTPUT</b>						
Rated power (kVA)	250	300	400	500	600	800
Active power (kW)	200	240	320	400	480	640
Number of phases	3 + N					
Nominal voltage	380 - 400 - 415 Vac three-phase + N					
Static stability	± 1%					
Dynamic stability	± 5% in 10 ms					
Voltage distortion with linear load	< 1%					
Voltage distortion with distorting load	< 3%					
Crest factor (I <sub>peak</sub> /I <sub>rms</sub> )	3:1					
Frequency stability on battery mode	0.05%					
Frequency	50 or 60 Hz (selectable)					
Overload	110% for 60'; 125% for 10'; 150% for 1'					
<b>ENVIRONMENTAL</b>						
Weight (kg)	2200		2600	3600	4000	5300
Dimensions (HxLxD) (mm)	1900 x 1630 x 850		1900 x 1630 x 1000	1900 x 3200 x 980		1900 x 4400 x 1000
Remote signalling	Voltage-free contacts					
Remote commands	EPO and bypass					
Communication	double RS232 + remote contacts + 2 communication interface slots					
Operating temperature	0°C / +40°C					
Relative humidity	< 95% non condensing					
Colour	Light grey RAL 7035					
Noise	< 70 dBA at 1 m			< 77 dBA at 1 m		< 80 dBA at 1 m
Protection rating	IP20					
Efficiency	Up to 94%					
Standards	Directives EC 73/23 - 93/68 - 2004/108; Safety IEC EN 62040-1; EMC IEC EN 62040-2; Performance IEC EN 62040-3					
Classification as per IEC 62040-3	(Voltage Frequency Independent) VFI - SS - 111					

## OPTIONS

Isolation transformer module

UPS Group Synchroniser (see UGS)

Hot connection device (see PSJ)

Interface for generator

Closed Loop parallel kit option (to be ordered with the UPS)

Empty or full battery cabinets for prolonged runtime



Master Plus 100-800 kVA

BATTERY BOX MODELS	BB 396-J8 BB 396-J9 BB 396-K1 BB 396-K2	BB 480-A0
MP MODELS	MP 100-200	MP 250-400
Dimensions (mm) h x w x d		

ISOLATION TRANSFORMER MODULE	TT 100 TT 120 TT 160	TT 200	TT 250 TT 300
MP MODELS	MP 100-160	MP 200	MP 250-300
Dimensions (mm) h x w x d			