

VARIANT® Compact

Hinge solutions with 3D-adjustment in the door leaf

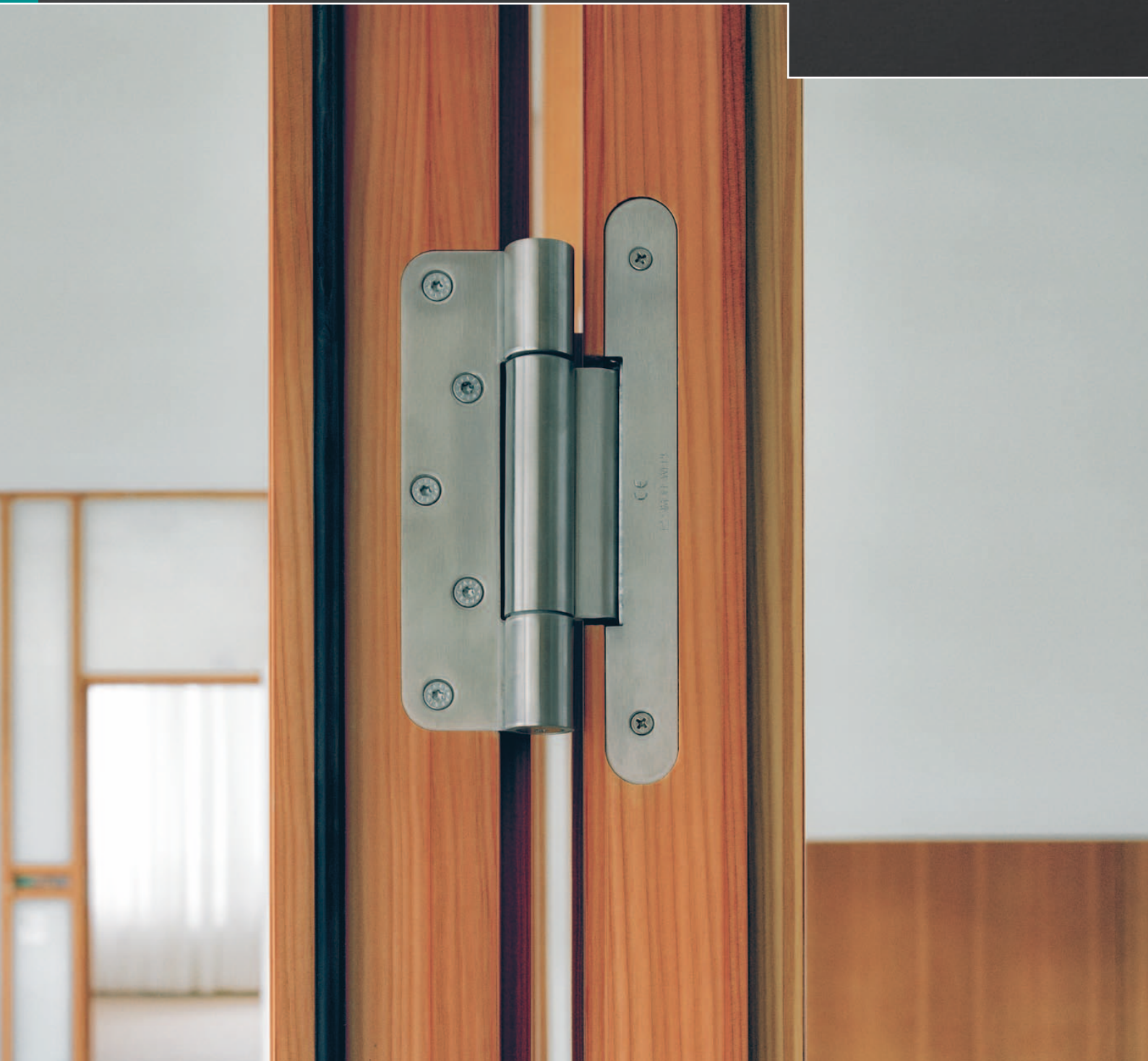

INDEX

VARIANT® Compact – Hinge solutions with 3D-adjustment in the door leaf

			Model versions for slim frame facings on block frames
8	VN 1937/120 Compact Planum	up to 120 kg	with reduced, elegant knuckle for rebated heavy-duty doors
9	VN 1937/160 Compact Planum	up to 160 kg	with reduced, elegant knuckle for rebated heavy-duty doors
10	VN 2927/120 Compact	up to 120 kg	for unrebated heavy-duty doors with thin block frames
11	VN 2927/120 Compact Planum	up to 120 kg	with reduced, elegant knuckle for unrebated heavy-duty doors
12	VN 2927/160 Compact	up to 200 kg	for unrebated heavy-duty doors
13	VN 2927/160 Compact Planum	up to 160 kg	with reduced, elegant knuckle for unrebated heavy-duty doors

			Model versions for the refurbishment
14	VN 3737/160 Compact	up to 160 kg	for rebated heavy-duty doors with casing frames and as retrofit hinge with steel frames
15	VN 3747/160 Compact	up to 160 kg	as retrofit hinge for unrebated heavy-duty doors with steel frames
16	VN 8937/160 U Compact	up to 160 kg	as retrofit hinge for rebated heavy-duty doors with steel frames
17	VN 8947/160 U Compact	up to 160 kg	as retrofit hinge for unrebated heavy-duty doors with steel frames

18 Service

MINIMALISTIC AND SLENDER

The VARIANT Compact hinge system offers an adjustable solution for narrow frame elevations. As a result of the trend to reduce everything to the essential within the architectural space, the focus is increasingly directed at the elements that define the space, such as the door, frame and hinges.

With its 3D receiver installed in the sash, VARIANT Compact offers a perfect solution for narrow frame elevations. It is also ideal for modern door refurbishments where the existing steel frames are reused and the door set is fitted with an up-to-date hinge system.

The exceptional slenderness of the VARIANT Compact Planum version completes the straight-lined, elegant all-over appearance of door and frame in narrow frame elevations.

OVERVIEW OF ADVANTAGES

- › compact, robust hinge-and-receiver unit
 - › adjustable receiver in sash
 - › easy 3D adjustment
 - › load capacities of up to 200 kg
 - › alternative version with elegant knuckle
 - › solutions for refurbishing existing doors
-



VARIANT® Compact Planum

VARIANT® COMPACT – WITH RECEIVER IN SASH

Thanks to the adjustable 3D receiver of the VARIANT Compact being installed in the sash, narrower frame elevations can be used. The compact, robust hinge-and-receiver unit can withstand high load values of up to 200 kg and is suitable for use with heavy-duty doors in the field of fire and smoke protection. An elegant cover on the receiver in the sash provides the finishing touch to this innovative hinge solution.

WELL PROPORTIONED: VARIANT COMPACT

The VARIANT Compact hinge system, with its maximum knuckle diameter of 22.5 mm, creates an overall effect of elegant delicateness when combined with a narrow frame elevation.

Its proportions within the door composition as a whole are elegant and perfectly sized. As a result, these low-key, minimalistic elements blend into the background while ensuring that doors continue to open and close smoothly.

COMPARISON

Standard design

Receiver in the frame

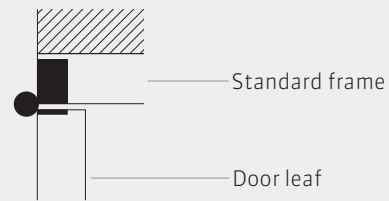

VARIANT® Compact

Receiver in door leaf for narrow frame elevations and readjustment

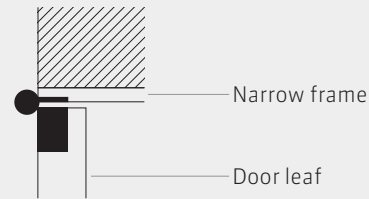



VARIANT® COMPACT PLANUM – FOR FRAME ELEVATIONS

When used with slim frame designs, the VARIANT Compact Planum version with its extremely slim, delicate knuckle, just 15 mm in diameter, and a load capacity of up to 160 kg, gives an even more elegant and straight-lined appearance to door sets in the domestic and heavy-duty sectors. The slim knuckle is positioned directly over the gap between the frame and the door, creating an overall effect of symmetry. Not only is the functional aspect considered, but a minimalistic look is also respected.

VARIANT PLANUM

Alternatively, the VARIANT VX AND VN Planum, hinges with the receiver in the frame as usual, blend delicately and aesthetically into a minimalistic door design – in both rebated and unrebated styles.



VARIANT® Compact



VARIANT® Compact Planum

IDEAL FOR REFURBISHING EXISTING DOORS

The forward-looking focus on refurbishing existing stock is another area of application for the VARIANT Compact series. Moving the receiver to the sash means that existing steel frames can continue to be used, saving both time and money, and the new door set can be fitted with an up-to-date hinge system. This means existing building elements can be managed sensitively and the concept of sustainability is taken into account with respect to a resource-efficient refurbishment.

GERMAN FEDERAL CONSTITUTIONAL COURT, KARLSRUHE

The building that houses the Federal Constitutional Court was built between 1965 and 1969, based on designs by the Berlin architect Paul Baumgarten. Its open construction is intended to convey the impression of democratic transparency. As part of the renovations begun in 2011, the VARIANT Compact hinge system was fitted. With the receiver in the door leaf and fixing on the frame side, it represented an ideal solution that allowed the existing frame to be kept.



**Read all about refurbishing in
our brochure „Refurbishing
Existing Stock“.**

VARIANT® VN

VN 1937/120 Compact Planum

with reduced, elegant knuckle for rebated heavy-duty doors with thin block frames

Block frames	rebated	up to 120 kg
--------------	---------	--------------

Product features

- for rebated heavy-duty doors
- for block frame
- with receiver in the door leaf
- continuously 3D adjustable (side +/- 3.0 mm, height +/- 3.0 mm, compression +/- 1.0 mm)
- internal torsion-proof pin
- concealed, maintenance-free axial-radial slide bearings
- with reduced, elegant knuckle
- integral security pin

Technical Data

Load capacity	i 2 hinges per door leaf (1x2m)	120.0 kg
Knuckle length		120.0 mm
Knuckle diameter		15.0 mm
Material thickness		3.0 mm
Cutter diameter		24.0 mm
Screws		5.0x50.0 mm

Finish

satin chromed (F1), satin brushed stainless steel, other finishes available upon request

Installation Tools

Jig		Universal milling frame
Frame	Template	No. 5 250574 6
Door, Step 1	Template	No. 5 250697 5
Door, Step 2	Template	No. 5 250698 5

Detailed information in our PRODUCTSELECTOR at www.simonswerk.com.

Functional areas

Fire resistance, Smoke resistance

Note

i The load capacity mentioned above refers to the use of 2 hinges per door leaf (1 x 2 m). A reinforcing dowel 12 x 50 mm per hinge is recommended when the door is subject to heavy usage.

The hinge system can also be used on blind frames.

Adapted for the application on doors within the high-class sector the elegant, diameter-reduced hinge knuckle is ideal for slim, recessed frame facings.

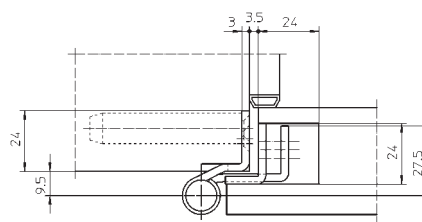
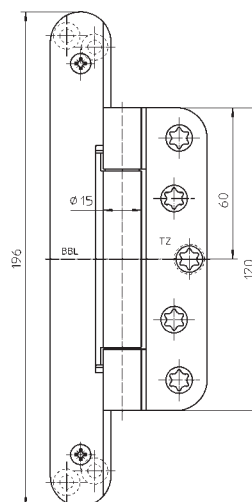

VARIANT® VN



VN 1937/160 Compact Planum

with reduced, elegant knuckle for rebated heavy-duty doors with thin block frames

Block frames	rebated	up to 160 kg
--------------	---------	--------------

Product features

- for rebated heavy-duty doors
- for block frame
- with receiver in the door leaf
- continuously 3D adjustable (side +/- 3.0 mm, height +/- 3.0 mm, compression +/- 1.0 mm)
- internal torsion-proof pin
- concealed, maintenance-free axial-radial slide bearings
- with reduced, elegant knuckle
- integral security pin

Technical Data

Load capacity	i 2 hinges per door leaf (1x2m)	160.0 kg
Knuckle length		160.0 mm
Knuckle diameter		15.0 mm
Material thickness		3.0 mm
Cutter diameter		24.0 mm
Screws		5.0x50.0 mm

Finish

satin chromed (F1), satin brushed stainless steel, other finishes available upon request

Installation Tools

Jig		Universal milling frame
Frame	Template	No. 5 250559 6
Door, Step 1	Template	No. 5 250697 5
Door, Step 2	Template	No. 5 250698 5

Detailed information in our PRODUCTSELECTOR at www.simonswerk.com.

Functional areas

Fire resistance, Smoke resistance

Note

i The load capacity mentioned above refers to the use of 2 hinges per door leaf (1 x 2 m). A reinforcing dowel 12 x 50 mm per hinge is recommended when the door is subject to heavy usage.

The hinge system can also be used on blind frames.

Adapted for the application on doors within the high-class sector the elegant, diameter-reduced hinge knuckle is ideal for slim, recessed frame facings.

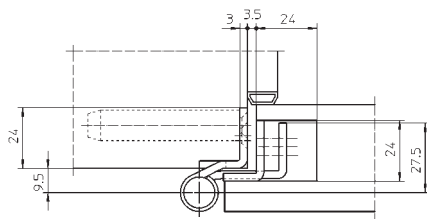
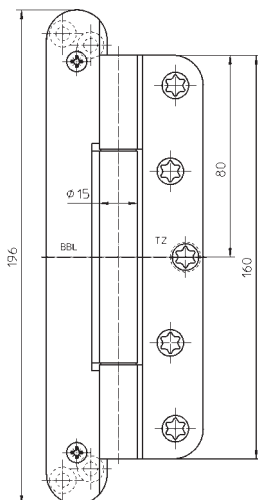

VARIANT® VN

VN 2927/120 Compact

for unrebated heavy-duty doors with thin block frames

Block frames	unrebated	up to 120 kg
---------------------	------------------	---------------------

Product features

- for unrebated heavy-duty doors
- for block frame
- with receiver in the door leaf
- continuously 3D adjustable (side +/- 3.0 mm, height +/- 3.0 mm, compression +/- 1.0 mm)
- internal torsion-proof pin
- concealed, maintenance-free axial-radial slide bearings
- integral security pin

Technical Data

Load capacity	i 2 hinges per door leaf (1x2m)	120.0 kg
Knuckle length		120.0 mm
Knuckle diameter		20.0 mm
Pin diameter		10.0 mm
Material thickness		3.5 mm
Cutter diameter		24.0 mm
Screws		5.0x50.0 mm

Finish

satin chromed (F1), satin brushed stainless steel, other finishes available upon request

Combination

Receiver	Block frames	VN 2900/120
----------	--------------	-------------

Installation Tools

Jig		Universal milling frame
Frame	Template	No. 5 250354 5
Door, Step 1	Template	No. 5 250697 5
Door, Step 2	Template	No. 5 250698 5
Door, Step 3	Template	No. 5 250699 5

Detailed information in our PRODUCTSELECTOR at www.simonswerk.com.

Functional areas

Fire resistance, Smoke resistance

Note

i The load capacity mentioned above refers to the use of 2 hinges per door leaf (1 x 2 m). Also available with security pin (MSTS).

A reinforcing dowel 12 x 50 mm per hinge is recommended when the door is subject to heavy usage.

The hinge system can also be used on blind frames.

Classification key

4	7	6	1	1	*	1	13
---	---	---	---	---	---	---	----

*depending on the finish

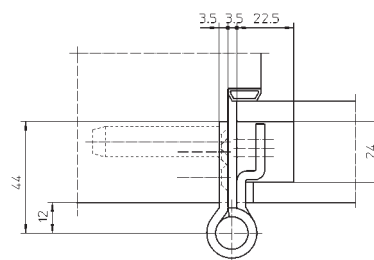
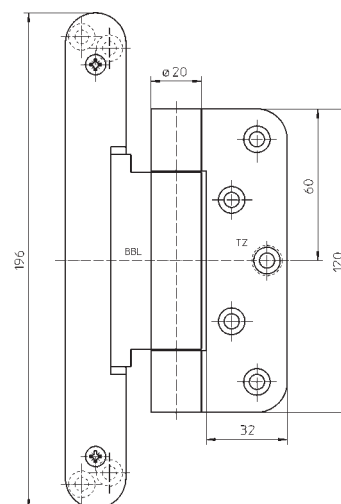

VARIANT® VN

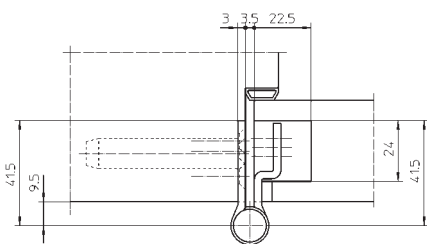
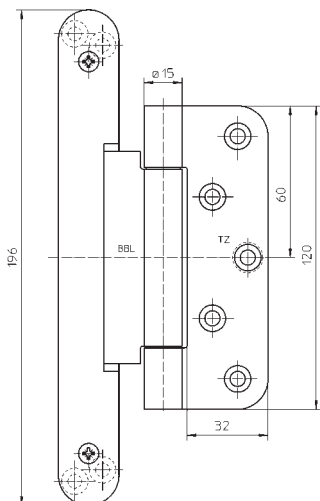

VN 2927/120 Compact Planum

with reduced, elegant knuckle for unrebated heavy-duty doors with thin block frames

Block frames	unrebated	up to 120 kg
--------------	-----------	--------------

Product features

- for unrebated heavy-duty doors
- for block frame
- with receiver in the door leaf
- continuously 3D adjustable (side +/- 3.0 mm, height +/- 3.0 mm, compression +/- 1.0 mm)
- internal torsion-proof pin
- concealed, maintenance-free axial-radial slide bearings
- with reduced, elegant knuckle
- integral security pin

Technical Data

Load capacity	i 2 hinges per door leaf (1x2m)	120.0 kg
Knuckle length		120.0 mm
Knuckle diameter		15.0 mm
Material thickness		3.0 mm
Cutter diameter		24.0 mm
Screws		5.0x50.0 mm

Finish

satin chromed (F1), satin brushed stainless steel, other finishes available upon request

Combination

Receiver	Block frames	VN 2900/120
----------	--------------	-------------

Installation Tools

Jig		Universal milling frame
Frame	Template	No. 5 250354 5
Door, Step 1	Template	No. 5 250697 5
Door, Step 2	Template	No. 5 250698 5
Door, Step 3	Template	No. 5 250699 5

Detailed information in our PRODUCTSELECTOR at www.simonswerk.com.

Functional areas

Fire resistance, Smoke resistance

Note

i The load capacity mentioned above refers to the use of 2 hinges per door leaf (1 x 2 m). A reinforcing dowel 12 x 50 mm per hinge is recommended when the door is subject to heavy usage.

The hinge system can also be used on blind frames.

Adapted for the application on doors within the high-class sector the elegant, diameter-reduced hinge knuckle is ideal for slim, recessed frame facings.

VARIANT® VN

VN 2927/160 Compact

for unrebated heavy-duty doors with thin block frames

Block frames	unrebated	up to 200 kg
---------------------	------------------	---------------------

Product features

- for unrebated heavy-duty doors
- for block frame
- with receiver in the door leaf
- continuously 3D adjustable (side +/- 3.0 mm, height +/- 3.0 mm, compression +/- 1.0 mm)
- internal torsion-proof pin
- concealed, maintenance-free axial-radial slide bearings

Technical Data

Load capacity	i 2 hinges per door leaf (1x2m)	200.0 kg
Knuckle length		160.0 mm
Knuckle diameter		22,5 mm
Pin diameter		10.0 mm
Material thickness		3.5 mm
Cutter diameter		24.0 mm
Screws		5.0x50.0 mm

Finish

satin chromed (F1), satin brushed stainless steel, other finishes available upon request

Installation Tools

Jig		Universal milling frame
Frame	Template	No. 5 250353 5
Door, Step 1	Template	No. 5 250697 5
Door, Step 2	Template	No. 5 250698 5
Door, Step 3	Template	No. 5 250699 5

Detailed information in our PRODUCTSELECTOR at www.simonswerk.com.

Functional areas

Fire resistance, Smoke resistance

Note

i The load capacity mentioned above refers to the use of 2 hinges per door leaf (1 x 2 m). Also available with security pin (MSTS).

A reinforcing dowel 12 x 50 mm per hinge is recommended when the door is subject to heavy usage.

The hinge system can also be used on blind frames.

Classification key

4	7	7	1	1	*1	1	14*2
---	---	---	---	---	----	---	------

*1 depending on the finish

*2 Durability test was carried through with weights of 200 kg

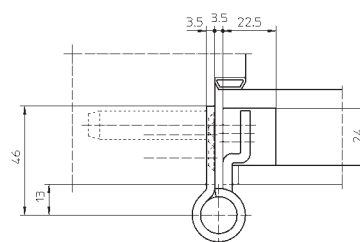
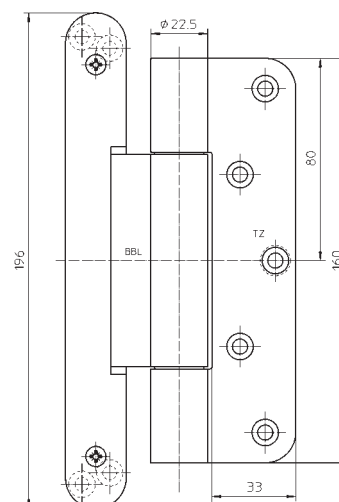

VARIANT® VN



VN 2927/160 Compact Planum

with reduced, elegant knuckle for unrebrated heavy-duty doors with thin block frames

Block frames	unrebrated	up to 160 kg
---------------------	-------------------	---------------------

Product features

- for unrebrated heavy-duty doors
- for block frame
- with receiver in the door leaf
- continuously 3D adjustable (side +/- 3.0 mm, height +/- 3.0 mm, compression +/- 1.0 mm)
- internal pin
- concealed, maintenance-free axial-radial slide bearings
- with reduced, elegant hinge knuckle
- integral security pin

Technical Data

Load capacity	i 2 hinges per door leaf (1x2m)	160.0 kg
Knuckle length		160.0 mm
Knuckle diameter		15.0 mm
Material thickness		3.0 mm
Cutter diameter		24.0 mm
Screws		5.0x50.0 mm

Finish

satin chromed (F1), satin brushed stainless steel, polished stainless steel, other finishes available upon request

Combination

Receiver	Block frames	VN 2900/160
----------	--------------	-------------

Installation Tools

Jig		Universal milling frame
Frame	Template	No. 5 250353 5
Door, Step 1	Template	No. 5 250697 5
Door, Step 2	Template	No. 5 250698 5
Door, Step 3	Template	No. 5 250699 5

Detailed information in our PRODUCTSELECTOR at www.simonswerk.com.

Functional areas

Fire resistance, Smoke resistance

Note

i The load capacity mentioned above refers to the use of 2 hinges per door leaf (1 x 2 m). A reinforcing dowel 12 x 50 mm per hinge is recommended when the door is subject to heavy usage. The hinge system can also be used on blind frames. Adapted for the application on doors within the high-class sector the elegant, diameter-reduced hinge knuckle is ideal for slim, recessed frame facings.

Classification key

4	7	5	1	1	*1	1	12*2
---	---	---	---	---	----	---	------

*1 depending on the finish

*2 Durability test was carried through with weights of 160 kg

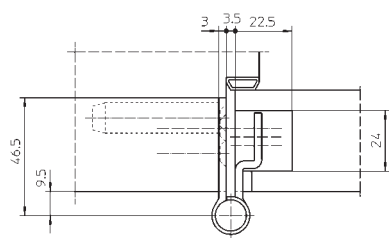
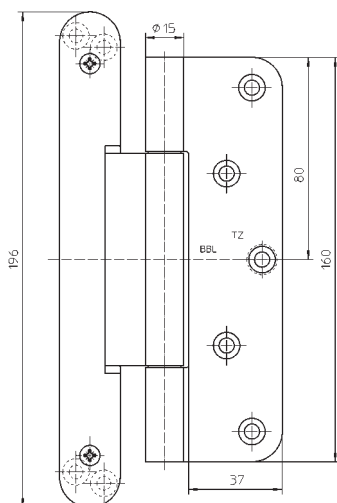

VARIANT® VN

VN 3737/160 Compact

as retrofit hinge for rebated heavy-duty doors with steel and casing frames

Retrofit	rebated	up to 160 kg
-----------------	----------------	---------------------

Product features

- for rebated heavy-duty doors
- for casing and steel frame
- for VARIANT VS receiver or blind rivet nut
- with receiver in the door leaf
- continuously 3D adjustable (side +/- 3.0 mm, height +/- 3.0 mm, compression +/- 1.0 mm)
- internal torsion-proof pin
- concealed, maintenance-free axial-radial slide bearings

Technical Data

Load capacity	i 2 hinges per door leaf (1x2m)	160.0 kg
Knuckle length		160.0 mm
Knuckle diameter		22,5 mm
Pin diameter		10.0 mm
Material thickness		3.5 mm
Cutter diameter		24.0 mm
Screws		5.0x50.0 mm

Finish

satin chromed (F1), satin brushed stainless steel, other finishes available upon request

Combination

Receiver	Casing frame	VS 4600/7 VS 4600/9
Accessories	Steel frame	Blind rivet nut M 10

Installation Tools

Jig	Universal milling frame Plug-on drilling jig VARIANT VN 3700/160 Serial drilling jig VARIANT VN 3700/160
-----	--

Step 1	Template	No. 5 250697 5
Step 2	Template	No. 5 250698 5

Detailed information in our PRODUCTSELECTOR at www.simonswerk.com.

Functional areas

Fire resistance, Smoke resistance

Note

i The load capacity mentioned above refers to the use of 2 hinges per door leaf (1 x 2 m). Also available with security pin (MSTS).

Classification key

4	7	7	1	1	*	1	14
---	---	---	---	---	---	---	----

*depending on the finish

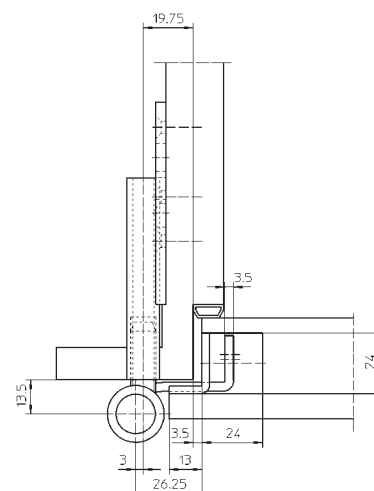
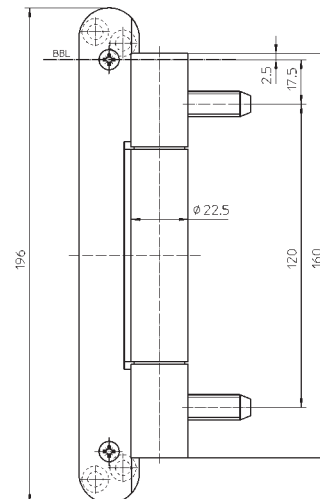

VARIANT® VN

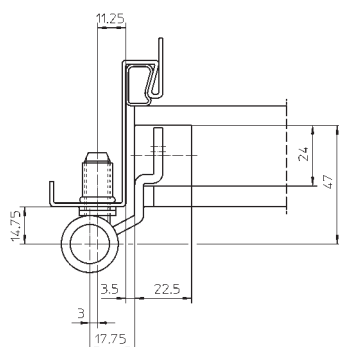
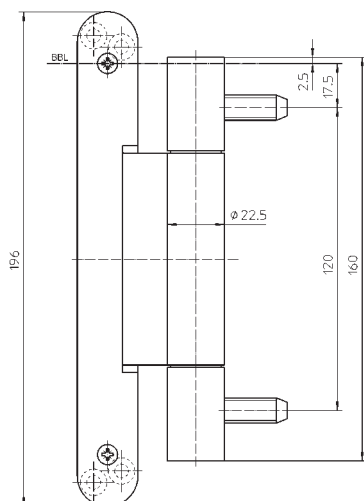

VN 3747/160 Compact

as retrofit hinge for unrebated heavy-duty doors with steel frames

Retrofit	unrebated	up to 160 kg
----------	-----------	--------------

Product features

- for unrebated heavy-duty doors
- for steel frame
- for blind rivet nut
- with receiver in the door leaf
- continuously 3D adjustable (side +/- 3.0 mm, height +/- 3.0 mm, compression +/- 1.0 mm)
- internal torsion-proof pin
- concealed, maintenance-free axial-radial slide bearings

Technical Data

Load capacity	i 2 hinges per door leaf (1x2m)	160.0 kg
Knuckle length		160.0 mm
Knuckle diameter		22,5 mm
Pin diameter		10.0 mm
Material thickness		3.5 mm
Cutter diameter		24.0 mm
Screws		5.0x50.0 mm

Finish

satin chromed (F1), satin brushed stainless steel, other finishes available upon request

Combination

Accessories	Steel frame	Blind rivet nut M 10
-------------	-------------	----------------------

Installation Tools

Jig	Universal milling frame	
	Plug-on drilling jig VARIANT VN 3700/160	
	Serial drilling jig VARIANT VN 3700/160	

Step 1	Template	No. 5 250697 5
Step 2	Template	No. 5 250698 5
Step 3	Template	No. 5 250699 5

Detailed information in our PRODUCTSELECTOR at www.simonswerk.com.

Functional areas

Fire resistance, Smoke resistance

Note

i The load capacity mentioned above refers to the use of 2 hinges per door leaf (1 x 2 m). Also available with security pin (MSTS).

Classification key

4	7	7	1	1	*	1	14
---	---	---	---	---	---	---	----

*depending on the finish

VARIANT® VN

VN 8947/160 U Compact

as retrofit hinge for unrebated heavy-duty doors with steel frames

Retrofit	unrebated	up to 160 kg
-----------------	------------------	---------------------

Product features

- for unrebated heavy-duty doors
- for steel frame
- for VARIANT VS receiver or blind rivet nut
- with receiver in the door leaf
- continuously 3D adjustable (side +/- 3.0 mm, height +/- 3.0 mm, compression +/- 1.0 mm)
- internal torsion-proof pin
- concealed, maintenance-free axial-radial slide bearings

Technical Data

Load capacity	i 2 hinges per door leaf (1x2m)	160.0 kg
Knuckle length		160.0 mm
Knuckle diameter		22,5 mm
Pin diameter		10.0 mm
Material thickness		3.5 mm
Cutter diameter		24.0 mm
Screws		5.0x50.0 mm

Finish

satin chromed (F1), satin brushed stainless steel, other finishes available upon request

Combination

Receiver	Steel frame	V 8600 V 8610
Accessories		Blind rivet nut M 10

Installation Tools

Jig		Universal milling frame Drilling jig VARIANT VN 8900/160 U
-----	--	---

Step 1	Template	No. 5 250697 5
Step 2	Template	No. 5 250698 5
Step 3	Template	No. 5 250699 5

Detailed information in our PRODUCTSELECTOR at www.simonswerk.com.

Functional areas

Fire resistance, Smoke resistance

Note

i The load capacity mentioned above refers to the use of 2 hinges per door leaf (1 x 2 m). Also available with security pin (MSTS). Please consider DIN reference.

Classification key

4	7	7	1	1	*	1	14
---	---	---	---	---	---	---	----

*depending on the finish

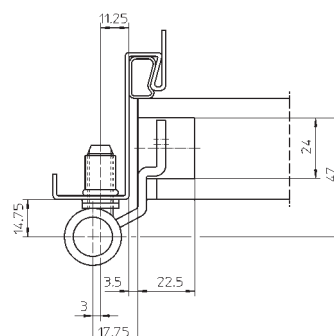
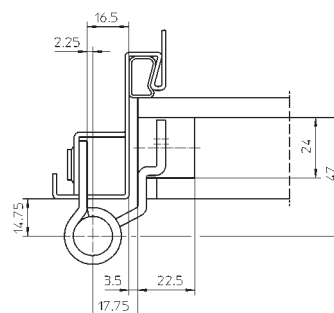
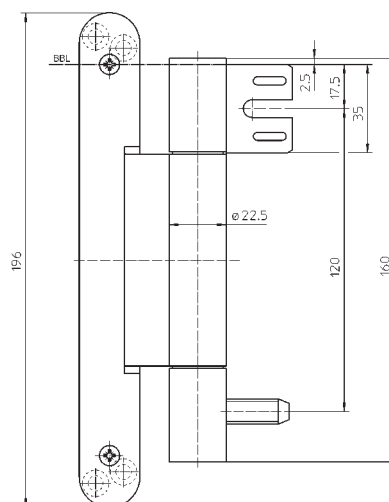

VARIANT® VN

VN 8937/160 U Compact

as retrofit hinge for rebated heavy-duty doors with steel frames

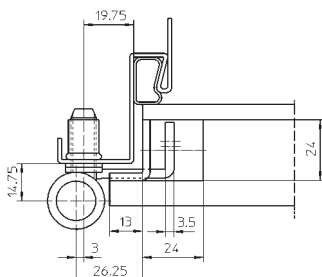
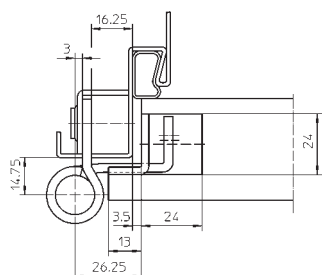
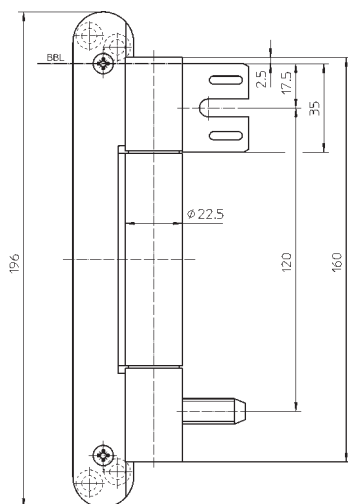

Retrofit	rebated	up to 160 kg
-----------------	----------------	---------------------

Product features

- for rebated heavy-duty doors
- for steel frame
- for VARIANT VS receiver or blind rivet nut
- with receiver in the door leaf
- continuously 3D adjustable (side +/- 3.0 mm, height +/- 3.0 mm, compression +/- 1.0 mm)
- internal torsion-proof pin
- concealed, maintenance-free axial-radial slide bearings

Technical Data

Load capacity	i 2 hinges per door leaf (1x2m)	160.0 kg
Knuckle length		160.0 mm
Knuckle diameter		22,5 mm
Pin diameter		10.0 mm
Material thickness		3.5 mm
Cutter diameter		24.0 mm
Screws		5.0x50.0 mm

Finish

satín chromed (F1), satín brushed stainless steel, other finishes available upon request

Combination

Receiver	Steel frame	V 8600 V 8610
Accessories		Blind rivet nut M 10

Installation Tools

	Universal milling frame
	Drilling jig VARIANT VN 8900/160 U
Step 1	Template 5 250697 5
Step 2	Template 5 250698 5

Detailed information in our PRODUCTSELECTOR at www.simonswerk.com.

Functional areas

Fire resistance, Smoke resistance

Note

i The load capacity mentioned above refers to the use of 2 hinges per door leaf (1 x 2 m). Also available with security pin (MSTS). Please consider DIN reference.

Classification key

4	7	7	1	1	*	1	14
---	---	---	---	---	---	---	----

*depending on the finish

QUALITY MARKS



FUNCTIONAL AREAS



SERVICE – COMPREHENSIVE EXPERTISE FOR YOUR DAILY WORK

We are happy to provide you with all the documentation you need to calculate which is the most suitable hinge system for your requirements. Please contact us: we would be delighted to work with you to choose the best solution – from high-quality standard sets right up to the most complex solutions.

Please visit our home page for any information not included in this brochure. You will find it easy to navigate through our user-friendly website to arrive at the detailed, comprehensive solutions.

All our brochures and data sheets can be requested in a printed version, or you can simply download them on the spot – and the same applies to our fitting instructions and routing data.

VISIT OUR PRODUCT SELECTOR

Whether you are a manufacturer, trade partner or designer, at www.simonswerk.com you can find precise, detailed product descriptions that will help you to choose the most suitable hinge systems.



You are here: Productselector

Quick search

Model description

Brand

Please select

Topic

Please select

Novelties

Please select

scope of application

- heavy-duty door
- residential door
- entrance door
- window
- metalworking

function range

- finger protection
- fire resistance, smoke resistance
- soundproof
- burglar resistance

product type

- hinge
- cover angle
- accessories
- receiver

type of door leaf

- timber
- metal
- glass
- PVCu
- aluminium

rebate

- rebated
- rebated flush
- unrebated

type of frame

- blind frame
- block frame
- casing frame
- steel frame
- aluminium frame

door weight (kg)

<input type="checkbox"/> 0-19	<input type="checkbox"/> 101-120
<input type="checkbox"/> 20-40	<input type="checkbox"/> 121-160
<input type="checkbox"/> 41-80	<input type="checkbox"/> 161-200
<input type="checkbox"/> 81-100	<input type="checkbox"/> 201-300



Technical information

Assistance in selecting the proper hinge for different applications.

[→ read more](#)



TECTUS Energy

Integrated and permanent energy transfer without ignoring the flush interior design.

[→ view model versions](#)



Novelties - Between door and frame

New hinge systems for applications on heavy-duty, residential and entrance doors.

[→ view model versions](#)

CONTAINS

VN 1937/120 Compact Planum
VN 1937/160 Compact Planum
VN 2927/120 Compact
VN 2927/120 Compact Planum
VN 2927/160 Compact
VN 2927/160 Compact Planum
VN 3737/160 Compact
VN 8937/160 U Compact
VN 8947/160 U Compact
VN 3747/160 Compact

PLEASE VISIT OUR PRODUCTSELECTOR ON:
www.simonswerk.co.uk



SIMONSWERK UK Ltd.

Burcot Works, Spring Street
Tipton, West Midland DY4 8TF
United Kingdom

Phone +44 (0)121 522 2848

Fax +44 (0)121 557 7042

sales@simonswerk.co.uk

www.simonswerk.co.uk