

Industrial Mixer HM-830



Description

The industrial mixer is specially designed for mixing of powders and granulars, and for addition of liquids, for instance animal fat, molasses and similar products up to 10% of the mixture.

The mixer is equipped with a horizontally mounted double auger, suspended in strong ball bearings.

In the mixing process the product is transported by the outer spiral in one direction (towards the outlet), and by the center spiral in the opposite direction. At the same time the rotation makes the product rotate around the center axle of the auger.

Note: cleaning door as shown on the illustration is extra equipment

Industrial Mixer HM-830

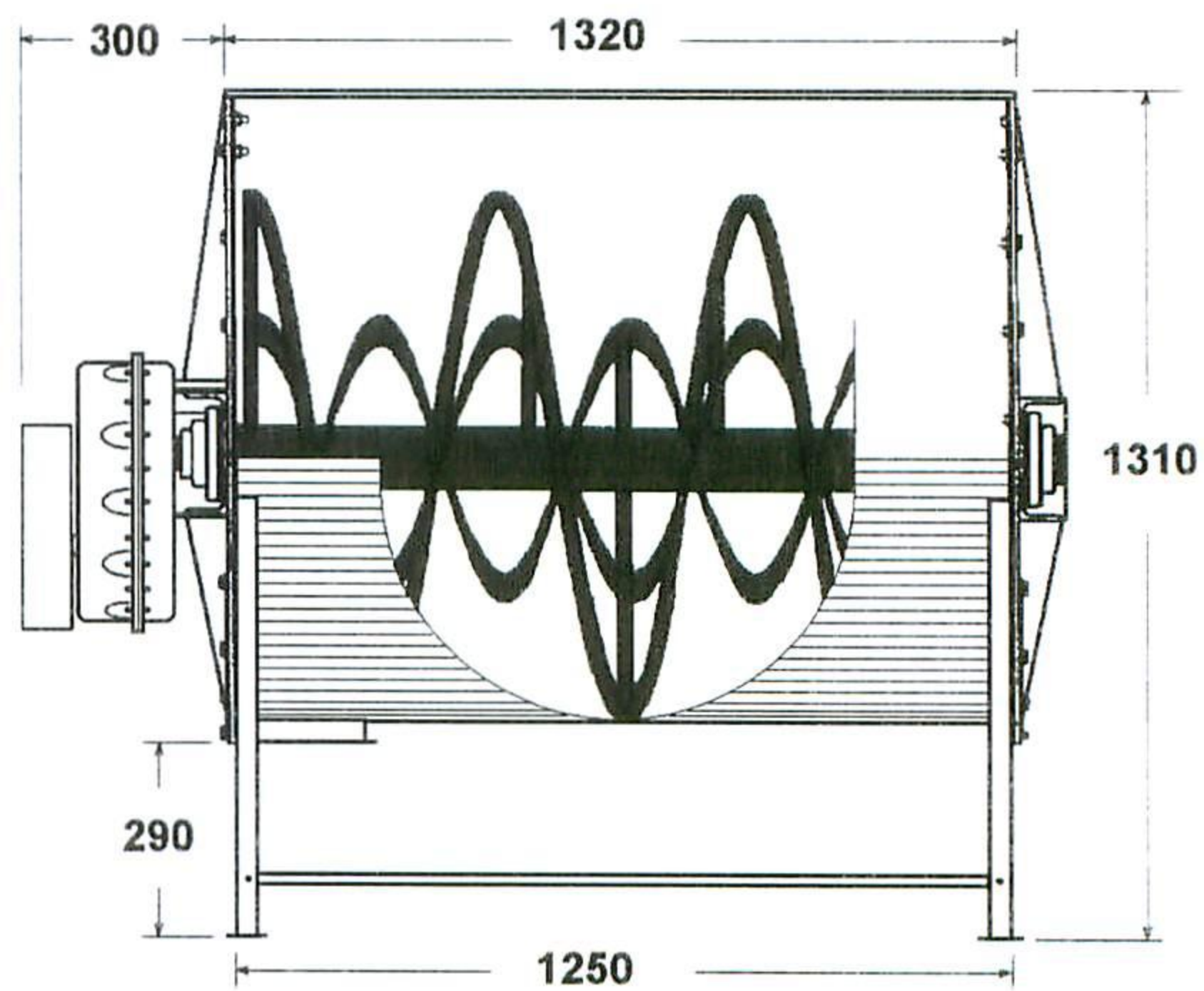
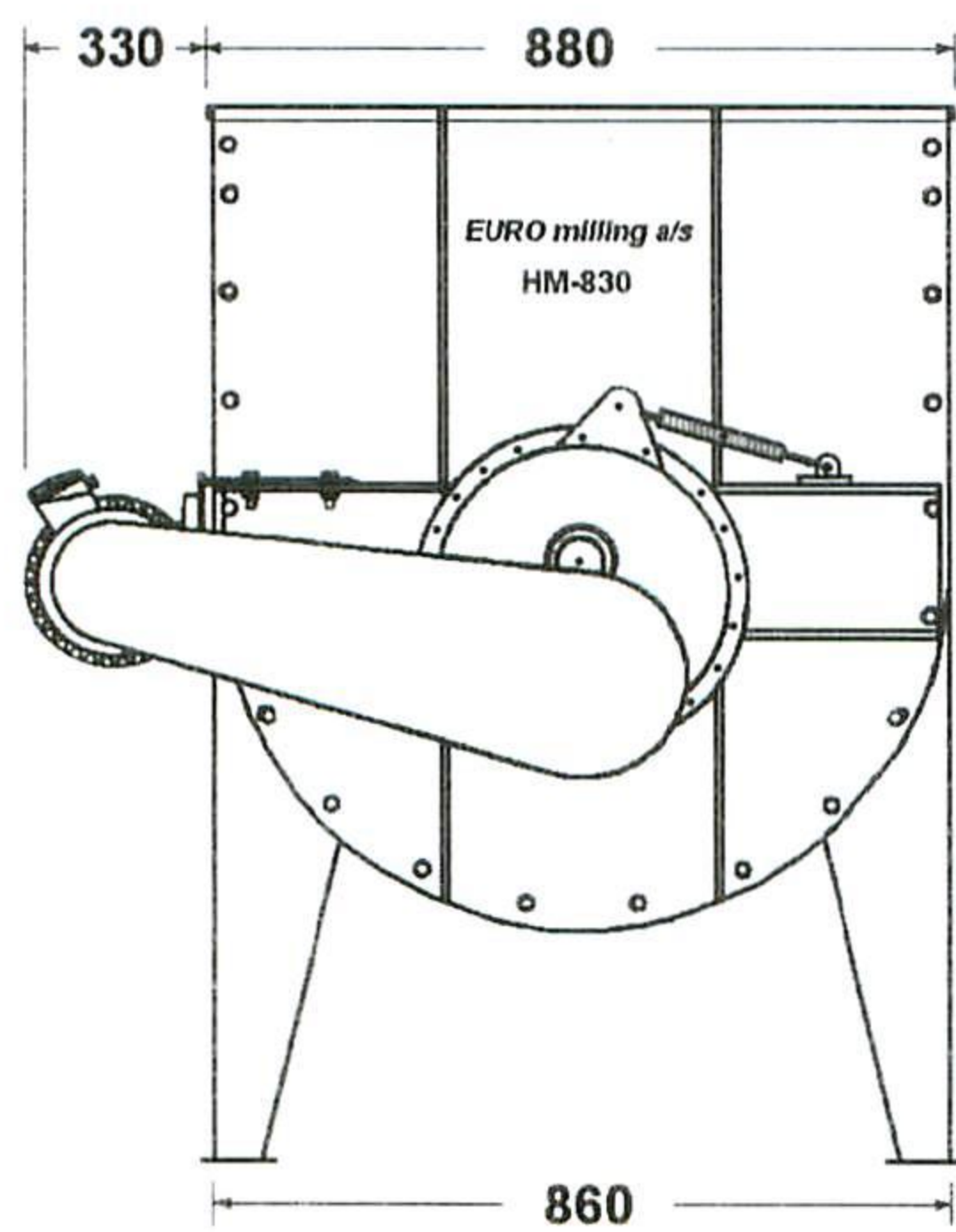
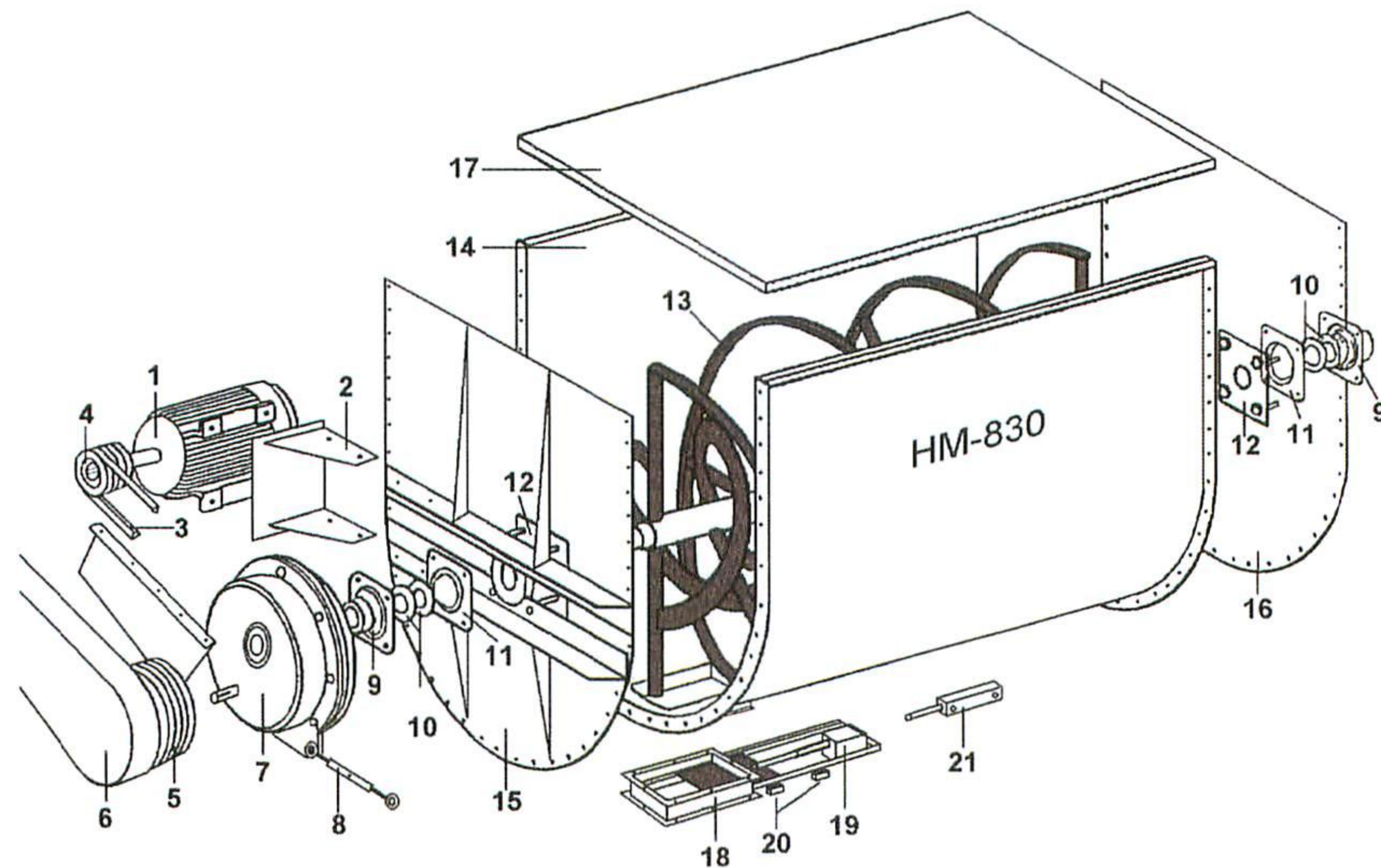

Motor	4,0 kW
Transmission	V-belts
Axle gear independantly suspended	TA45 1:30,4
Auger revolutions	26
Total volume / litres	830
Effective mixing volume / litres	665
Volume at specific weight 0,65	432 kg
Mixing time / min	4-5
Noise level	70 dB(A)
Weight incl. motor	400 kg
Weight pre-bin with slide section	
Weight lower bin with emptying auger	
Weight leg support	

Industrial Mixer HM-1450



Description

The industrial mixer is specially designed for mixing of powders and granulars, and for addition of liquids, for instance animal fat, molasses and similar products up to 10% of the mixture.

The mixer is equipped with a horizontally mounted double auger, suspended in strong ball bearings.

In the mixing process the product is transported by the outer spiral in one direction (towards the outlet), and by the center spiral in the opposite direction. At the same time the rotation makes the product rotate around the center axle of the auger.

Industrial Mixer HM-1450

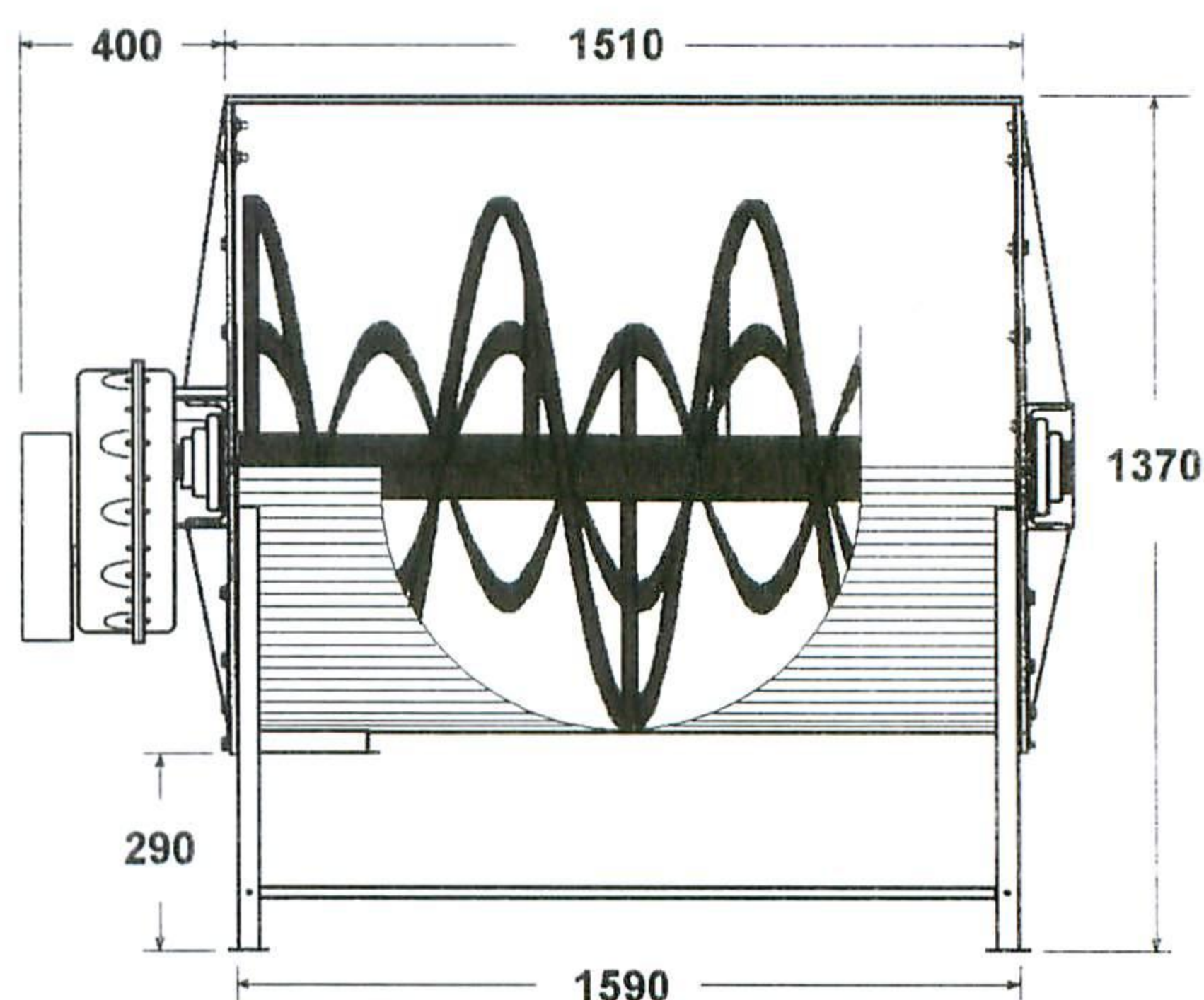
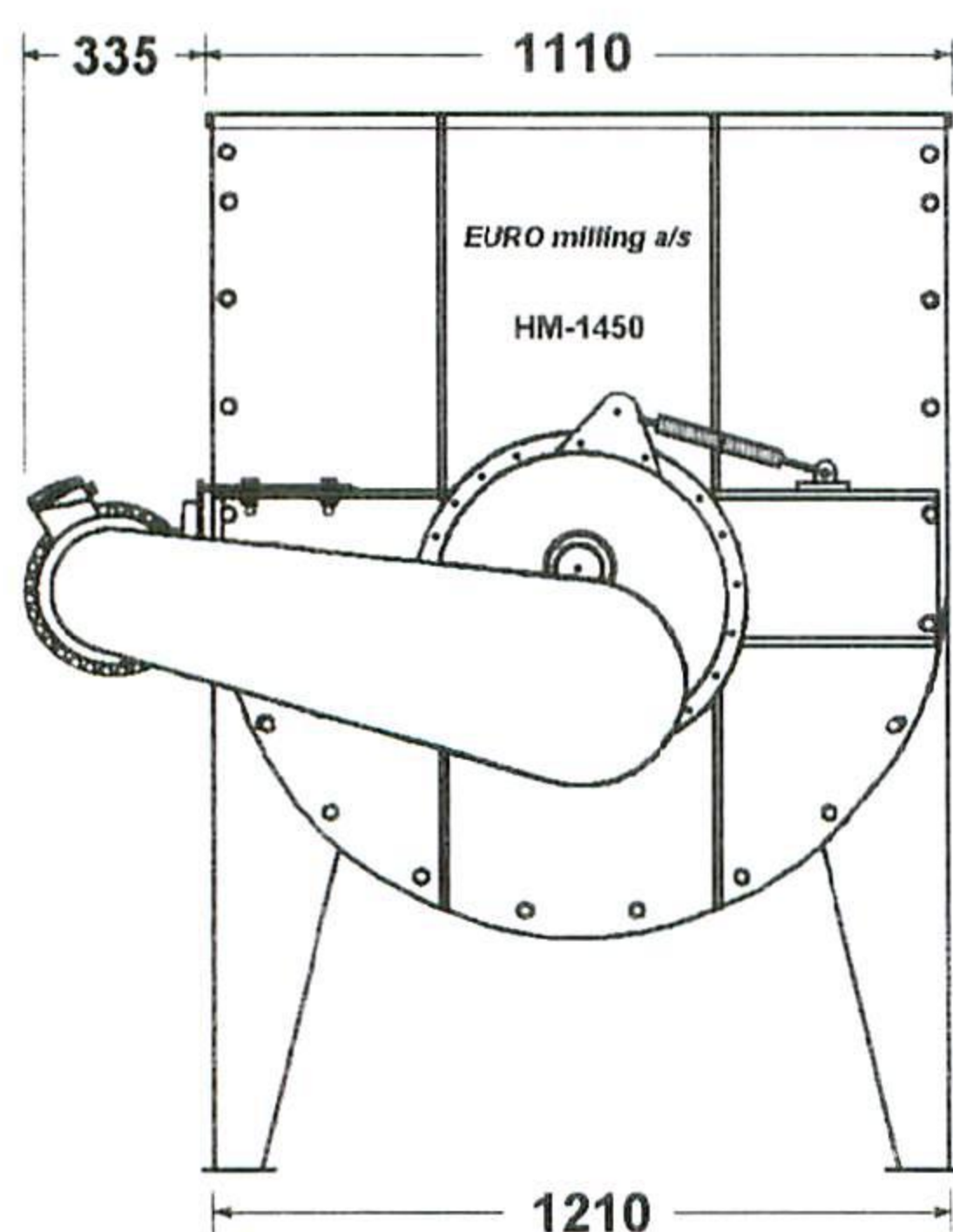
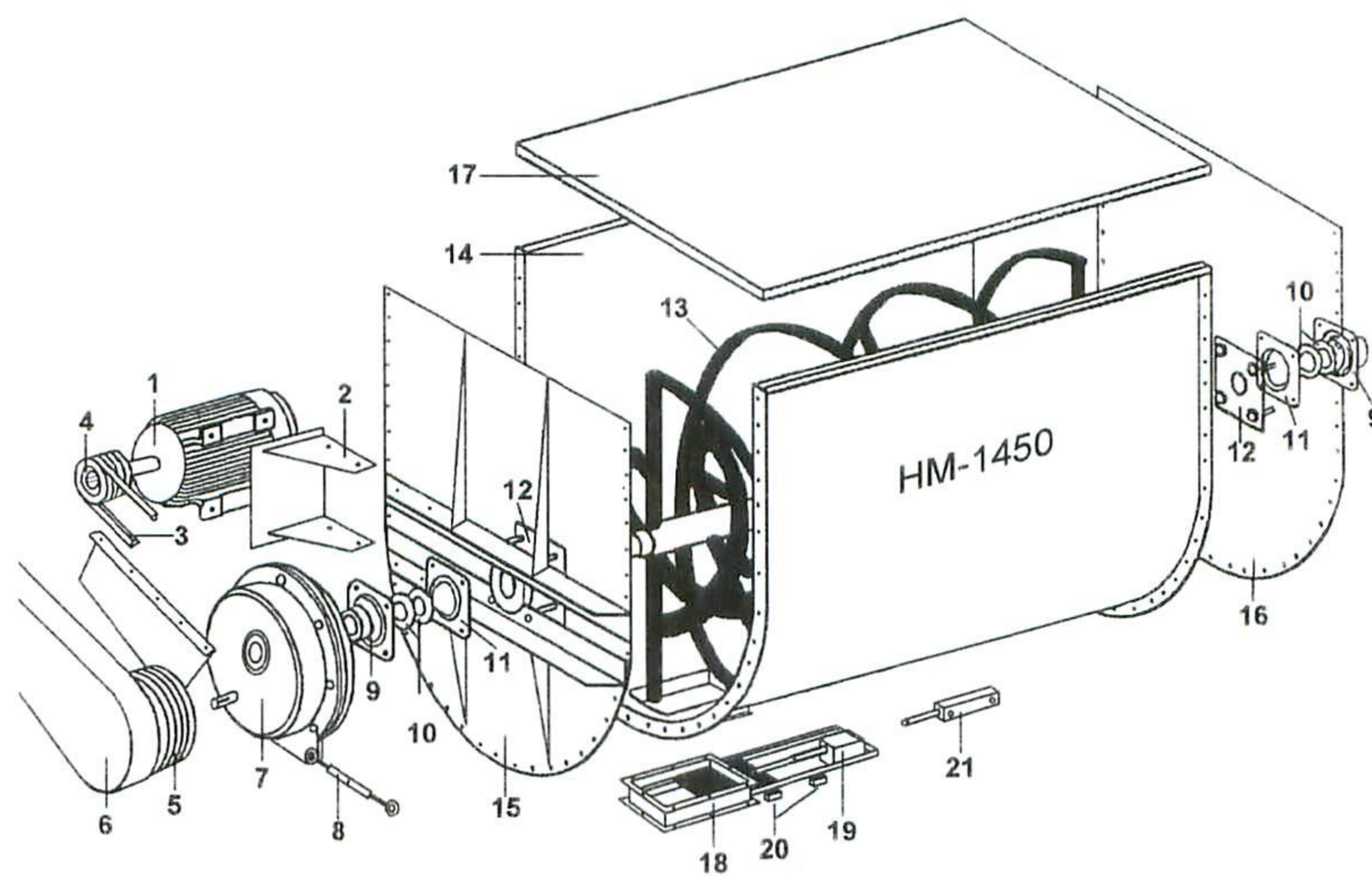

Motor	7,5 kW
Transmission	V-belts
Axle gear independantly suspended	TA60 1:30,4
Auger revolutions	13
Total volume / litres	1450
Effective mixing volume / litres	1160
Volume at specific weight 0,65	754 kg
Mixing time / min	4-5
Noise level	70 dB(A)
Weight incl. motor	885 kg
Weight pre-bin with slide section	
Weight lower bin with emptying auger	
Weight leg support	

Industrial Mixer HM-2000



Description

The industrial mixer is specially designed for mixing of powders and granulars, and for addition of liquids, for instance animal fat, molasses and similar products up to 10% of the mixture.

The mixer is equipped with a horizontally mounted double auger, suspended in strong ball bearings.

In the mixing process the product is transported by the outer spiral in one direction (towards the outlet), and by the center spiral in the opposite direction. At the same time the rotation makes the product rotate around the center axle of the auger.

Industrial Mixer HM-2000

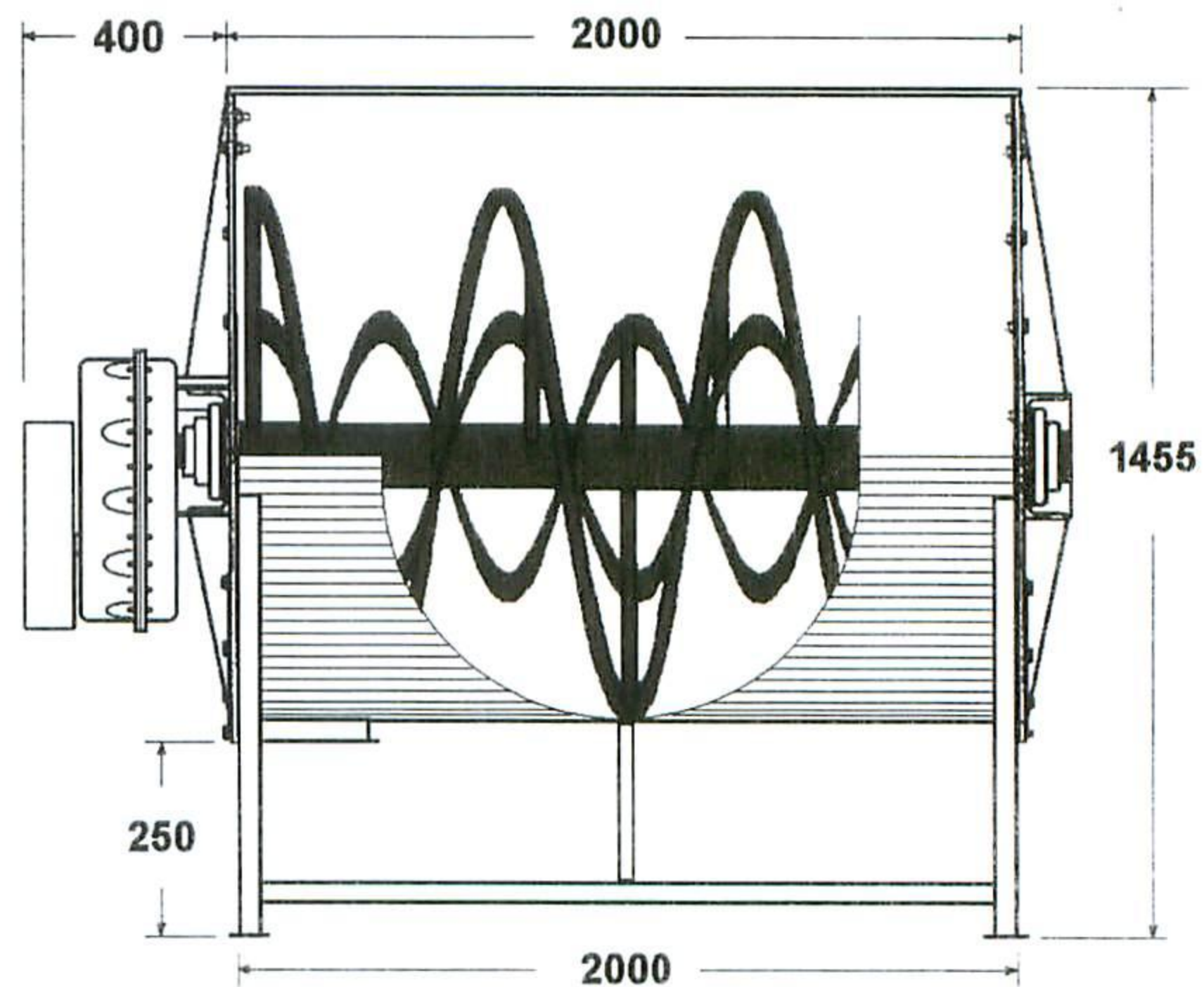
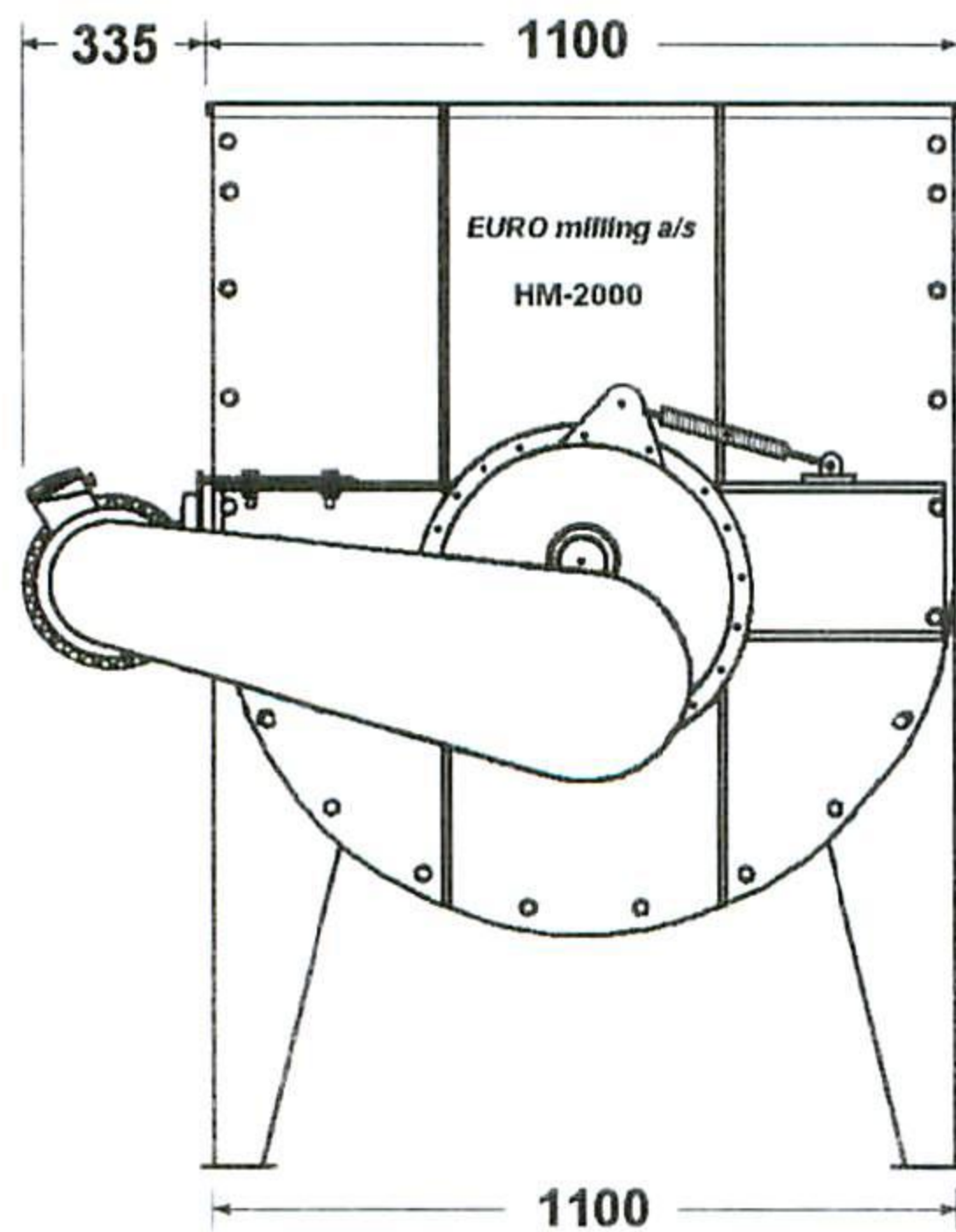
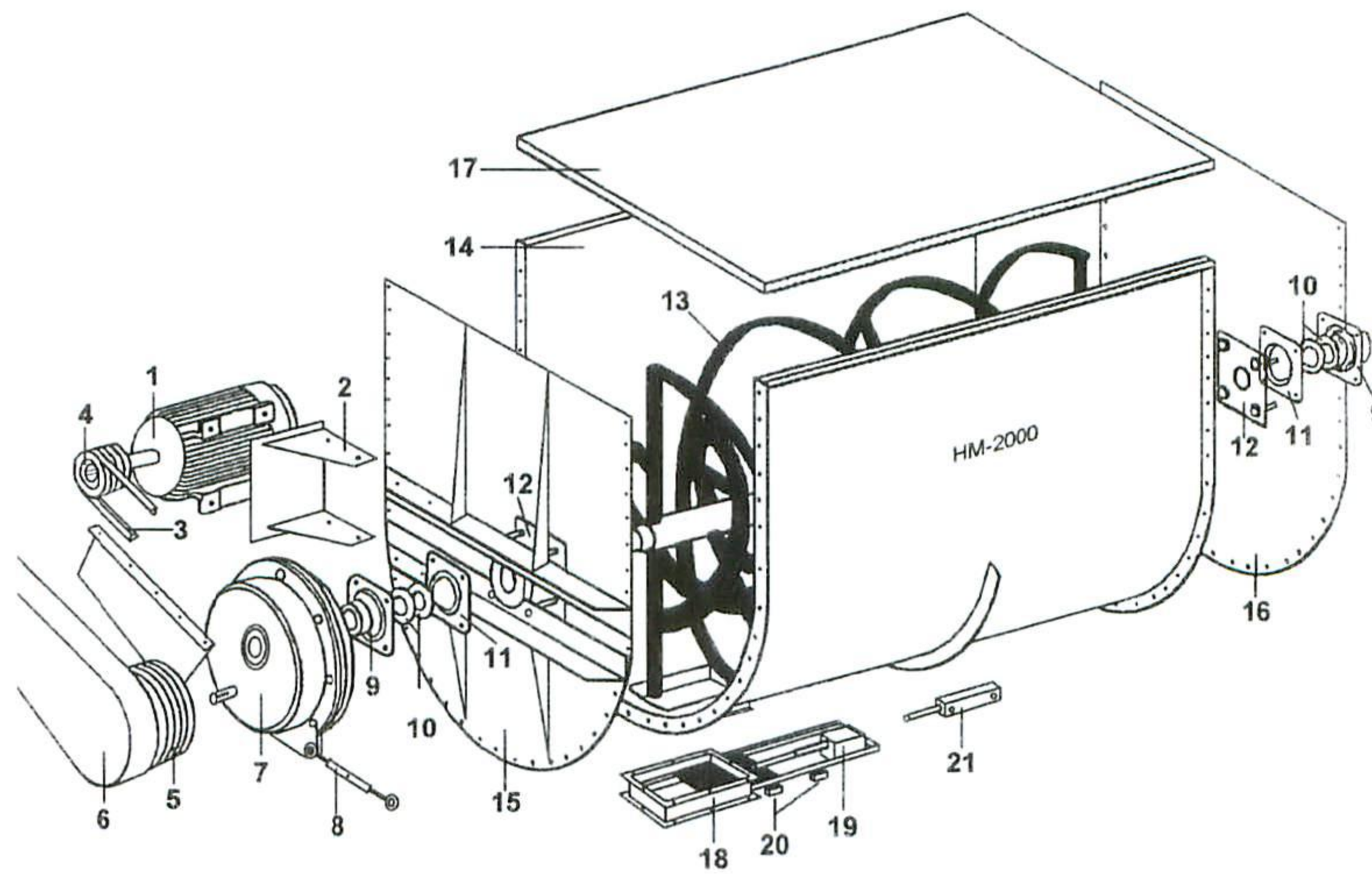

Motor	7,5 kW
Transmission	V-belts
Axle gear independantly suspended	TA60 1:30,4
Auger revolutions	13
Total volume / litres	2100
Effective mixing volume / litres	1540
Volume at specific weight 0,65	1000 kg
Mixing time / min	4-5
Noise level	70 dB(A)
Weight incl. motor	950 kg
Weight pre-bin with slide section	
Weight lower bin with emptying auger	
Weight leg support	