



LOW VOLUME VENTILATION

KOOL IT – KEEP IT SAFE, COMPLETE KITS FOR ABOVE FLOOR AND LEVEL FLOOR

Aeration (LVV) should commence immediately the laterals are covered. Thereafter, the recommended treatment periods for various moisture contents are decided by monitoring the temperature.

Aeration of grain changes the air within the bulk of the crop, and it is not intended to force air through the crop. Therefore, fan selection is important, as a guide CB7 (75 tonnes), CB8 (160 tonnes), CB9 (300 tonnes), BDC Systems is able to advise on any specific situation.

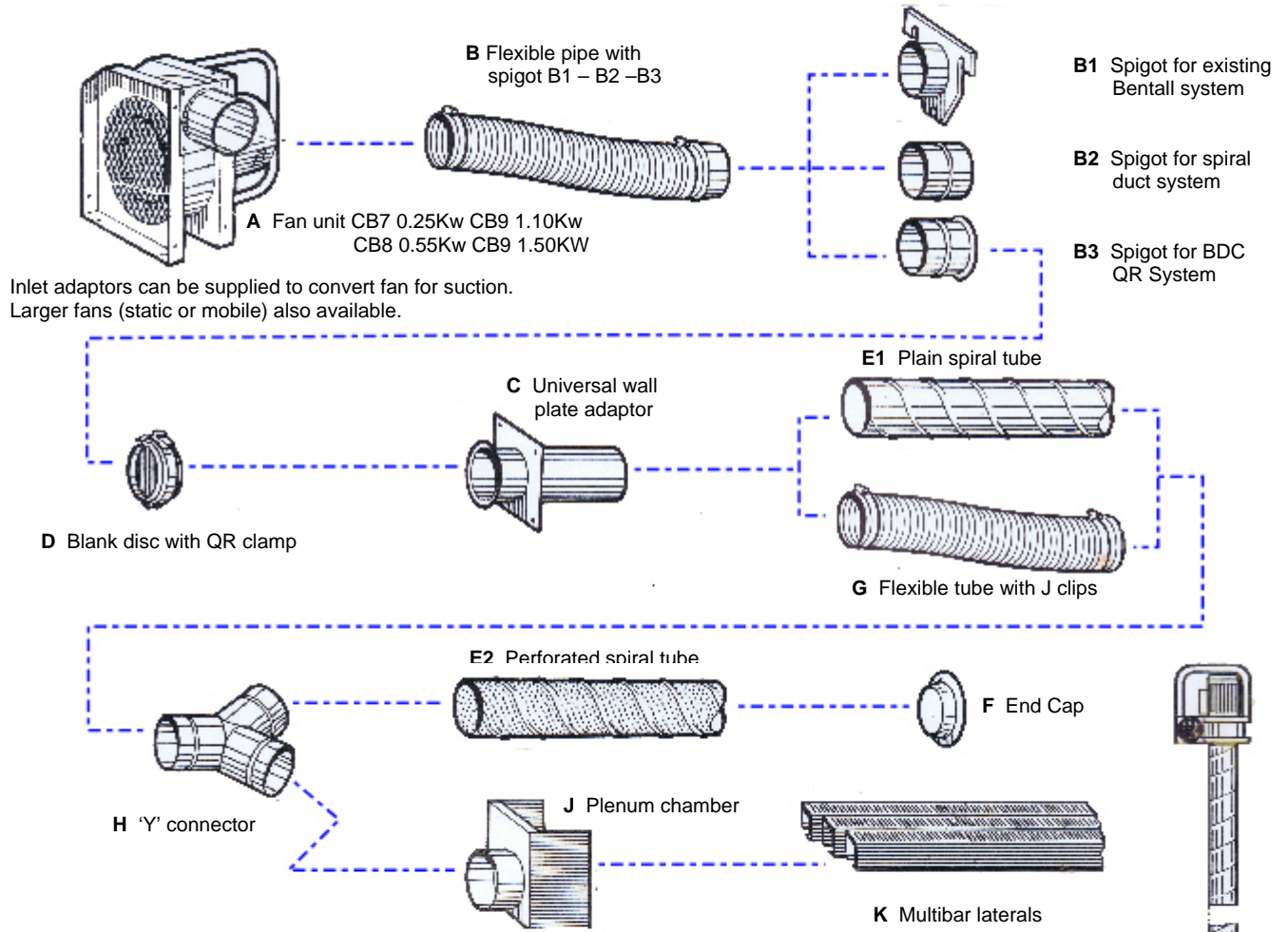

KOOL-IT AIRSPEAR & AIRSTACK

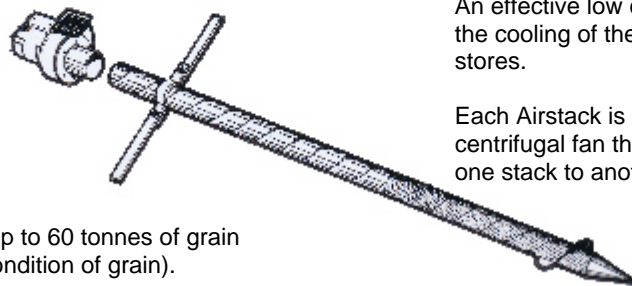

An effective low cost system to improve the cooling of the crop in existing stores.

Each Airstack is free-standing with a centrifugal fan that can be moved from one stack to another.



One Airspear will ventilate up to 60 tonnes of grain (dependent on depth and condition of grain).

Special perforations for small seeds, auger flight and handle to aid entry into crop.

AERATION SYSTEMS FOR FLOOR STORES

'MULTIBAR' LEVEL FLOOR VENTILATION LATERAL

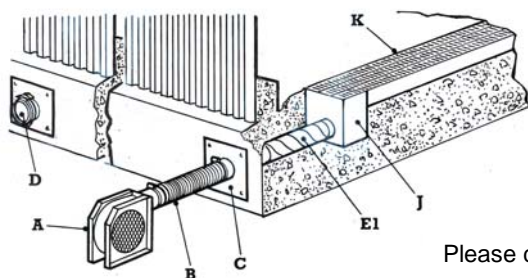

The 'Multibar' Lateral is manufactured from galvanised steel with a louvred top, suitable for all cereals and oilseeds. 'Multibar' is produced 2" wide by 3' long. This system is suitable for drive over by most agricultural vehicles.

Laterals should not be spaced further apart than the grain depth. ie grain 8' deep laterals should not be more than 8' apart.

Please consult BDC Systems on planning layout requirements to suit proposed storage building.

AERATION SYSTEMS FOR LARGE BULK

'CORRADUCT' HALF ROUND ABOVE FLOOR VENTILATION LATERAL

Three sizes available with fully perforated or closed top to suit airflow requirements. Ideally suited for large peak loaded stores to provide wide lateral spacings lengthwise in the building.

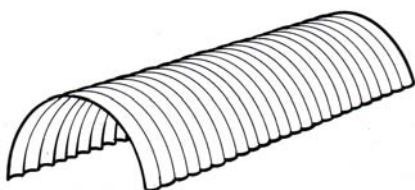

MODEL	M ²	L	W	H
G900	0.095	920	480	240
G1600	0.165	920	640	320
G2500	0.255	920	800	400

Effective coverage length 870mm

'DRIVEOVER' LEVEL FLOOR VENTILATION LATERAL

12", 15" and 18" wide x 36" long. Two types available: Standard duty for general farm use and Heavy duty for intensive farm use.

Consult BDC Systems for recommended design layout of duct sizes, airflows and fan sizes to suite.

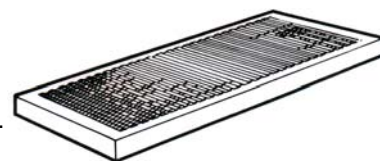

AERATION SYSTEMS FOR ROUND SILOS

ABOVE FLOOR SYSTEM

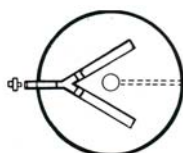
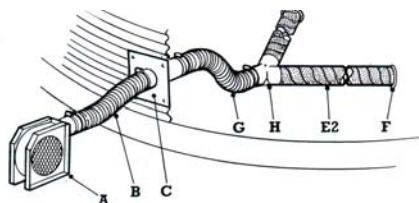

12' - 15'
DIA
SILOS

ABOVE FLOOR

C	1	-	Wall plate adaptor
D	1	-	100mm Blank disc
G	1	-	100mm Flexible tube
H	1	-	100mm 'Y' piece
E2	4	-	100mm Perf tube 1m
B2	2	-	100mm Connector
F	2	-	100mm End cap

LEVEL FLOOR

C	1	-	Wall plate adaptor
D	1	-	100mm Blank disc
E1	1	-	100mm Plain tube 1m
H	1	-	100mm 'Y' piece
E1	2	-	100mm plain tube 0.25m
J	2	-	6" Plenum chamber
K	12	-	Multibars

LEVEL FLOOR SYSTEM

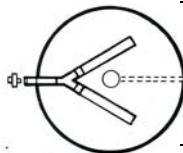
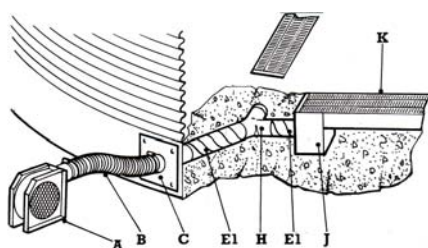

18' DIA
SILOS

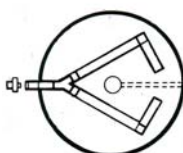

21' - 24'
DIA
SILOS

C	1	-	Wall plate adaptor
D	1	-	150mm Blank disc
G	1	-	150mm Flexible tube
H	1	-	150mm 'Y' piece
E2	6	-	150mm Perf tube 1m
B2	4	-	150mm Connector
F	2	-	150mm End cap

C	1	-	Wall plate adaptor
D	1	-	150mm Blank disc
G	1	-	150mm Flexible tube
H	1	-	150mm 'Y' piece
E2	10	-	150mm Perf tube 1m
B2	2	-	150mm Connector
F	2	-	150mm End cap
F	2	-	150mm 90° bend

C	1	-	Wall plate adaptor
D	1	-	150mm Blank disc
E1	1	-	150mm Plain tube 1m
H	1	-	150mm 'Y' piece
E1	2	-	150mm Plain tube 0.25m
J	2	-	8" Plenum chamber
K	40	-	Multibars
	2	-	Corner covers

BDC Systems Ltd reserves the right to change specifications without notice.
Further advice and information for specific requirements available on request.

BDC Systems Limited

Prospect Farm, Monxton
Andover, Hampshire SP11 7DA

Telephone: 01264 710900

Fax: 01264 710987

Email: info@bdcsystems.com

Intl Tel: +44 (0) 1264 710900

Intl Fax: +44 (0) 1264 710987

Website: www.bdcsystems.com

