

# Multi PD Dense Phase Pump for pneumatic conveying systems



## Typical applications for Multi PD Dense Phase Pumps include:

- Handling fly ash from ESPs or bag filters
- Connection of upto 8 pumps to the same pipeline
- Conveying distances upto 750m at rates of upto 200 tph

## Pneumatic Conveying

The pneumatic conveying process, enclosed and dust free, ensures material transfer complies with health and safety and other international regulations for industry and is less harmful to the environment than traditional mechanical methods.

## The original Dome Valve®

Central to the operating efficiency of all Schenck Process pneumatic conveying systems, or as a stand alone valve is the original Dome Valve® which incorporates a unique and highly reliable inflatable sealing arrangement. The original Dome Valve® was developed by Clyde Materials Handling\* in 1974 for use with pneumatic conveying systems and as a stand alone product.

## Dense Phase Conveying Technology

The Schenck Process Dense Phase system capitalises on all the assets of pneumatic conveying: simplicity, reliability and flexibility. Ensuring minimal breakage of friable products, the extensive range of Dense Phase machines shares standard components, individually tailored to handle specific requirements of a wide range of materials.

## Multi PD Pump

The Schenck Process Multi PD Pump is designed for handling fly ash from ESPs or from bag filters and can be used to convey directly to the main silos without using an intermediate hopper. There can be up to 8 pumps connected on the same pipeline with an ESP. The most efficient arrangement is for the vessels to be connected across the gas stream of the ESP so that each vessel receives approximately an even loading. No level probe is required in the ESP when using the Multi PD pump system

The Multi-PD pump system is able to convey distances up to 750m and at higher conveying velocities than with multi Dense Phase vessels. The Multi-PD system also has lower specific air consumption and utilise smaller pipe sizes to achieve the same conveying rate as a multi Dense Phase system.

# Standard Fabrication

Dense Phase vessel assemblies supplied complete with Dome Valve®, electro-pneumatic controls and air supply piping, strainer, pressure regulation and control equipment pre-piped and pre-wired ready for connection to isolated air and electric supplies.

- Vessels can be manufactured to most international pressure vessel codes and for a working pressure of 7 barg standard. Specific details are available on request.
- Vessels are free standing, special foundations are not required.
- Optional isolating valve and adapter are shown for reference only.
- Final working dimensions to be confirmed by certified drawings.

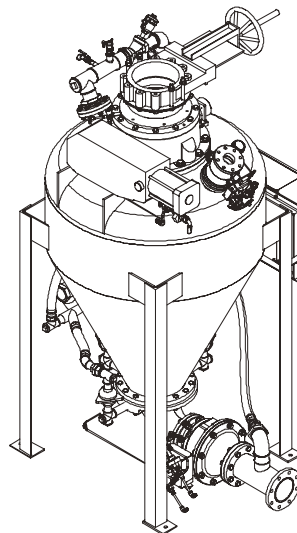
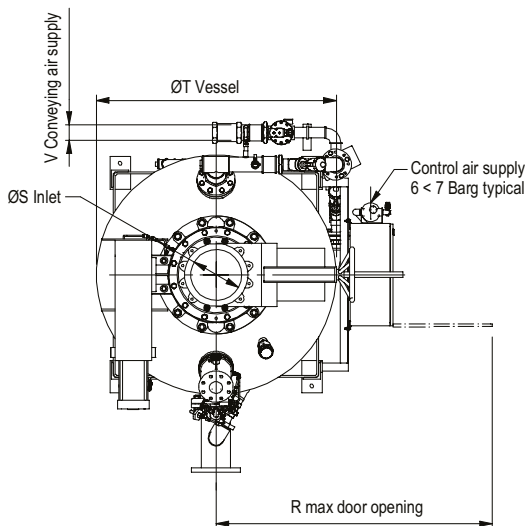
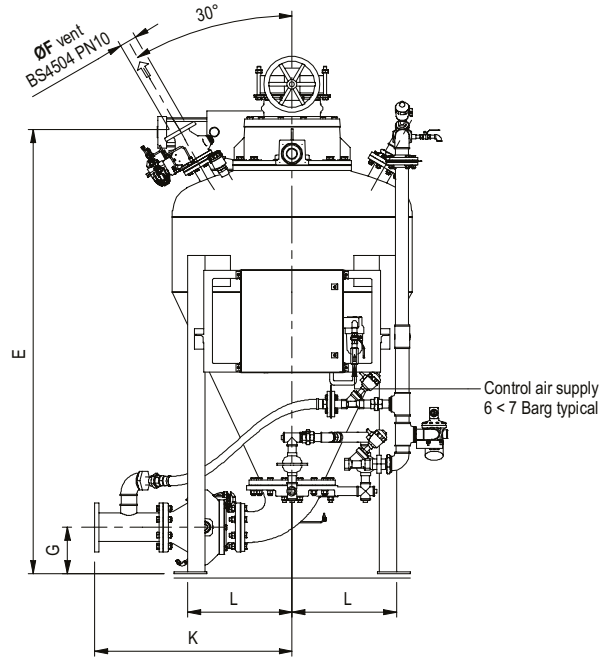
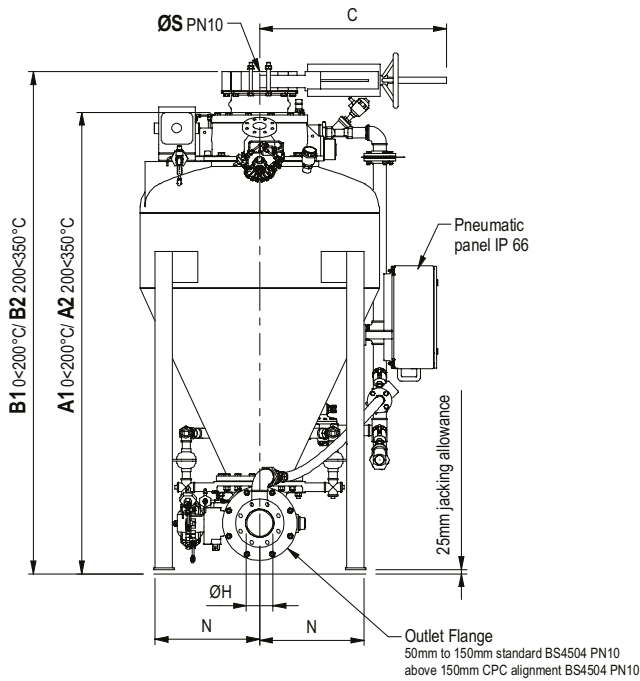

# Product Range

## PD Pumps

Model	A1	A2	B1	B2	C	E	ØF	G	ØH	K	L	M	N	R(Max)	ØS	ØT	ØV	KG
8/8/3	1445	1465	1690	1710	792	1448	51	192	77.9	873	775	365	365	1356	200	900	1 1/2"	625
12/8/3	1650	1670	1895	1915	792	1655	51	177	77.9	873	815	405	405	1396	200	900	1 1/2"	675
12/8/4	1743	1763	1998	2018	792	1748	51	245	102.3	1064	815	405	405	1396	200	900	2"	725
20/8/4	2002	2022	2247	2267	792	1998	51	246	102.3	1164	895	485	485	1476	200	1100	2"	850
20/8/5	2004	2024	2249	2269	792	2000	51	300	128.1	1316	865	455	455	1433	200	1100	2"	1020
20/12/4	2067	2079	2337	2349	1092	2018	78	247	102.3	1163	895	485	485	1476	300	1100	2"	1080
20/12/5	2068	2080	2338	2350	1092	2020	78	300	128.1	1316	860	460	460	1432	300	1100	2 1/2"	1240
25/8/4	2120	2140	2365	2385	792	2099	51	246	102.3	1163	935	510	510	1516	200	1200	2"	950
25/12/4	2195	2207	2465	2477	1092	2134	78	246	102.3	1163	935	510	510	1516	300	1200	2"	1160
30/8/5	2251	2271	2496	2516	792	2227	51	295	128.1	1356	935	510	510	1516	200	1200	2 1/2"	1145
30/8/6	2251	2271	2496	2516	792	2227	51	295	154.1	1356	935	510	510	1516	200	1200	3"	1180
30/12/5	2323	2335	2593	2605	1092	2262	78	295	128.1	1353	935	510	510	1516	300	1200	2 1/2"	1370
30/12/6	2323	2335	2593	2605	1092	2262	78	295	154.1	1356	935	510	510	1516	300	1200	3"	1390
40/8/5	2432	2452	2677	2697	792	2393	51	295	128.1	1151	1035	610	610	1616	200	1400	2 1/2"	1310
40/12/5	2507	2519	2777	2789	1092	2428	78	295	128.1	1151	1035	610	610	1616	300	1400	2 1/2"	1530
50/8/5	2622	2642	2867	2887	792	2583	51	295	128.1	1151	1035	610	610	1616	200	1400	2 1/2"	1260
50/12/5	2697	2709	2967	2979	1092	2618	78	295	128.1	1151	1035	610	610	1616	300	1400	2 1/2"	1580
50/12/6	2697	2709	2967	2979	1092	2618	78	295	154.1	1154	1035	610	610	1616	300	1400	3"	1620
50/12/8	2639	2651	2909	2921	1092	2556	78	310	202.7	1490	1020	610	610	1601	300	1400	4"	1900
70/12/5	2945	2957	3215	3227	1092	2871	78	295	128.1	1151	1070	660	660	1651	300	1600	2 1/2"	1740
70/12/6	2945	2957	3215	3227	1092	2871	78	295	154.1	1154	1070	660	660	1651	300	1600	3"	1780
70/12/8	2913	2925	3183	3195	792	2839	78	335	202.7	1288	1120	710	710	1701	300	1600	4"	1980
70/12/10	2918	2930	3188	3200	1092	2843	78	360	254.4	1671	1070	660	660	1651	300	1600	6"	
100/12/6	3390	3402	3660	3672	1092	3316	78	295	154.1	1154	1070	660	660	1651	300	1600	3"	1995
100/12/8	3358	3350	3628	3640	1092	3284	78	335	202.7	1288	1120	710	710	1701	300	1600	4"	2220
100/12/10	3363	3375	3664	3676	1092	3288	78	360	254.4	1671	1070	660	660	1651	300	1600	5"	
100/12/12	3363	3375	3644	3656	1092	3316	78	445	304.9		1671	660	660	1651	300	1600	6"	2500
150/12/6	3692	3704	3962	3974	1092	3627	78	295	154.1	1154	1270	860	860	1851	300	2000	3"	3550
150/12/8	3660	3672	3930	3942	1092	3594	78	335	202.7	1287	1270	860	860	1851	300	2000	4"	2760
150/12/10	3665	3677	3903	3915	1092	3599	78	360	254.4	1721	1270	860	860	1851	300	2000	5"	
150/12/12	3665	3677	3903	3915	1092	3568	78	370	304.9		1270	860	860	1851	300	2000	6"	
220/12/8	4294	4306	4564	4576	1092	4239	78	335	202.7	1288	1270	860	860	1851	300	2000	4"	3625
220/12/10	4310	4326	4548	4560	1092	4244	78	360	254.4	1721	1270	860	860	1851	300	2000	5"	
220/12/12	4304	4316	4542	4556	1092	4238	78	395	304.9		1270	860	860	1851	300	2000	6"	
300/12/10	5049	5061	5288	5300	1092	4983	78	360	254.4	1721	1270	860	860	1851	300	2000	5"	
300/12/12	5044	5056	5286	5298	1092	5003	78	395	304.9		1282	860	860	1851	300	2000	6"	
450/12/12	5881	5893	6123	6135	1092	5815	78	395	304.9			960	960		300	2200	6"	

Custom applications available on request

**Schenck Process UK Limited**  
**Carolina Court, Lakeside, Doncaster**  
**DN4 5RA England**  
Tel: +44 (0) 1302 321 313  
Fax: +44 (0) 1302 554 400  
[enquiries@schenckprocess.co.uk](mailto:enquiries@schenckprocess.co.uk)  
[www.schenckprocess.co.uk](http://www.schenckprocess.co.uk)

we make processes work