

s87 bollard



Above and right, powder coated grey s87 galvanized steel bollard with aluminium top.



description

Painted galvanised steel with machined aluminium top.

dimensions

Diameter 89mm, wall thickness 3mm, height 1200/1500mm.
(1000mm above ground to meet NDA/DDA recommendations).

options

Root fixed, below ground flange fixed, above ground flange fixed. Ground socket box for removable option, pad lock type or hidden grub screw type. Choice of colours.

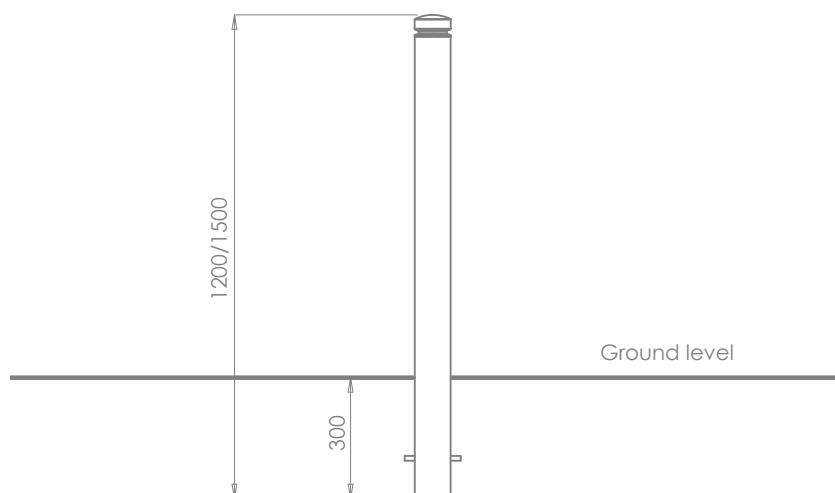
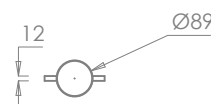

s87 AGFF Fixing Instructions

(for areas already paved)

- 1 Ensure that the surface which the bollard is to be fixed to is of sufficient size and strength for this purpose.
- 2 Position the bollard in the desired location and mark hole positions.
- 3 Drill following fixing manufacturer's instructions to suit the chosen fixing. Choose a fixing which will accept an M10 SS CSK bolt, either a mechanical anchor (such as Hilti HSC-IR M10*60) or an internally threaded fixing designed for chemical fixing (such as Hilti HIS-RN M10xL [length to suit]). **IMPORTANT**, the depth of the hole must be sufficient to allow the fixing to be fully embedded in the concrete rather than partially in the paver and partially in the concrete.
- 4 Insert the fixings into the ground following fixing manufacturer's instructions.
- 5 Reposition the bollard and screw in M10 SS CSK (stainless steel with countersunk head) into the 4 no. fixings. Where chemical fixing is used (such as Hilti HIT-HY 150) leave sufficient time to cure.
- 6 Tighten the bolts.

Foundations

Foundations must be to engineers specification. Omos recommends a minimum cube size of 400mm.

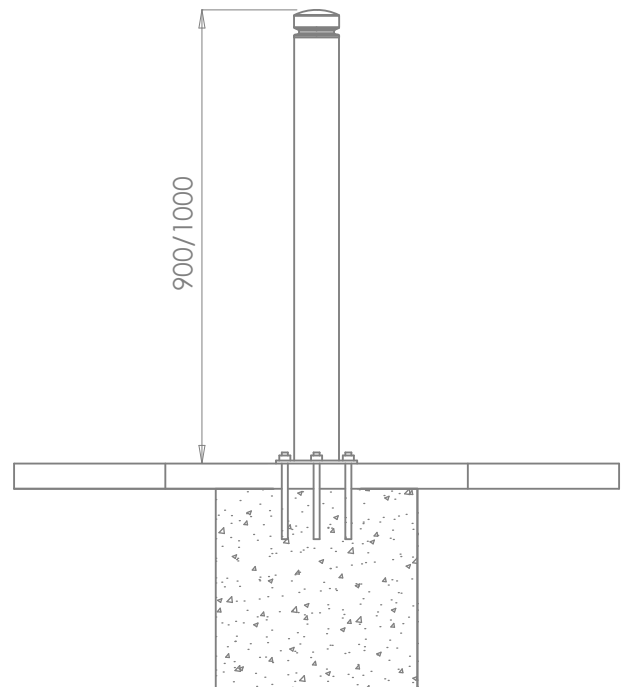
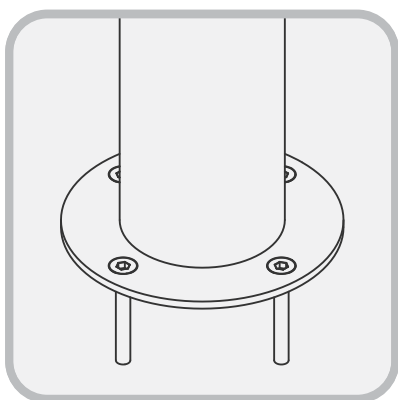
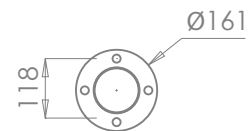

Above, fixing details.

s87 BGFF Fixing Instructions

(for areas already paved)

- 1 Cast foundation to engineers specification where bollard is to be located. The surface of the foundation must be level and finished to 100mm +10mm, -0mm. Leave to fully cure.
- 2 Position the bollard in the desired location and mark hole positions.
- 3 Drill 12mm holes to a depth of 150mm (or more depending on thickness of paver), insert M12 through bolts (such as Hilti HSA M12).
- 4 Use shims if necessary to ensure the correct height and plumb. Tighten bollard in position.
- 5 Where necessary cut or core drill the paving slabs and reinstate.
- 6 Render neatly around bollard with non shrink grout, removing any grout residue.

Foundations

Foundations must be to engineer's specification. Omos recommends a minimum cube size of 400mm.

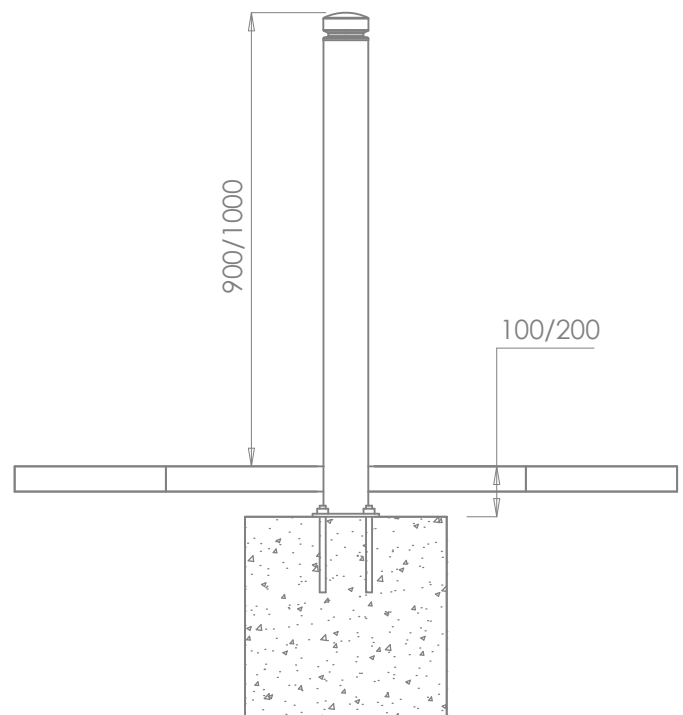
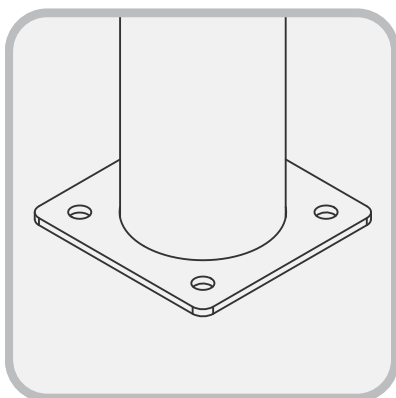
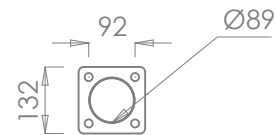

Above, fixing details.

s87 RF Fixing Instructions

(for areas already paved)

note: as an alternative to setting the bollard directly into the foundation, a plastic pipe may be set in the foundation allowing the bollard to be fixed at a later date.

- 1 Set out the position of the bollard/s.
- 2 Where the area has been paved remove sufficient pavers to facilitate excavation.
- 3 Excavate holes to engineer's specification.
- 4 Position bollard precisely ensuring correct position, height and plumb. Prop securely in position.
- 5 Back fill holes with concrete (35N20) leaving sufficient depth for paving slabs and bedding.
- 6 Once set remove props.
- 7 Where necessary cut or core drill the paving slabs and reinstate.
- 8 Render neatly around bollard with non shrink grout, removing any grout residue.

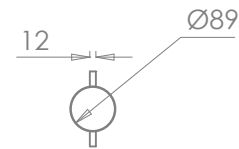

Foundations

Foundations must be to engineer's specification. Omos recommends a minimum cube size of 400mm.

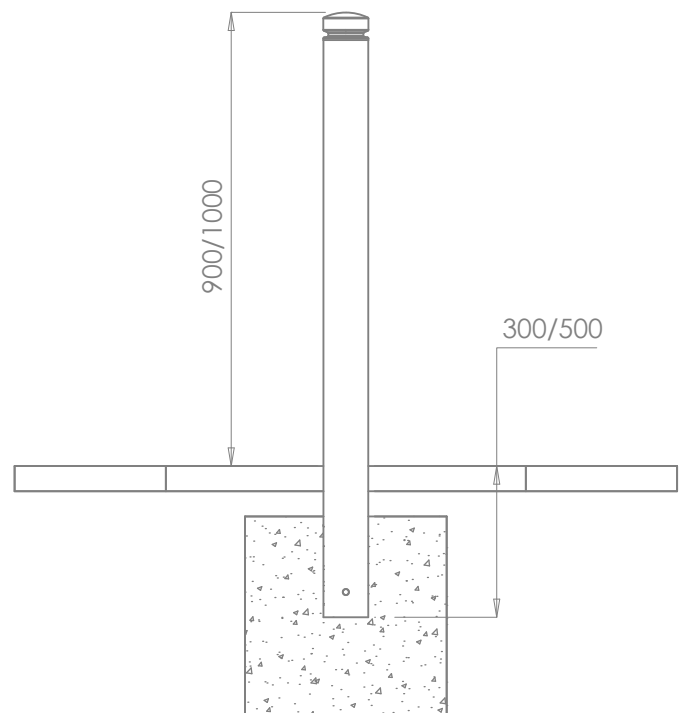
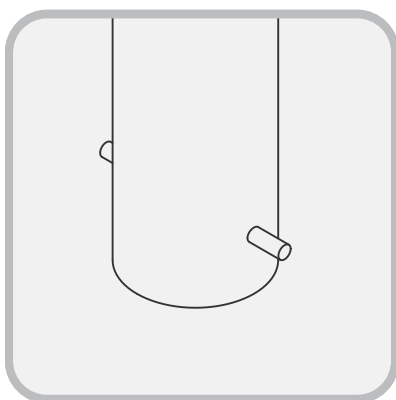

Above, fixing details.

s87 Care and Maintenance Guidelines

The s87 bollard is constructed from galvanized steel with a machined aluminium top, materials which are highly corrosion resistant. Despite the material's corrosion resistant properties some care is required to maintain a bright appearance.

The extent to which cleaning is required will depend on a number of factors including environmental conditions, construction activity and level of use.

Maintaining the painted finish

The s87 is finished in polyester powder, a plastic coating which is baked on to the metal. This is a highly durable finish which will last for many years. To maintain the original appearance of the metalwork it should be cleaned regularly using warm soapy water. Avoid the use of abrasive cleaners as they may damage the surface finish.

Should the paint become chipped or scratched it can be touched up using acrylic based paint. If the damage has penetrated the galvanized coating (entire bollard excluding the aluminium top) the area should be cleaned with a wire brush and a zinc rich primer should be applied prior to the top coat. For further advice contact Omos on + 353 45 899802.



Right, s87 bollard detail.