

## HYDRANT VALVES

Hydrant valves are a common part of the marine market.

When quoting a valve you will require the following information to be able to quote.

### 1.) PATTERN

This identifies the valve type.  
There are 4 different patterns:

- A.) Right Angle
- B.) Straight Through
- C.) Bib Nose
- D.) Oblique

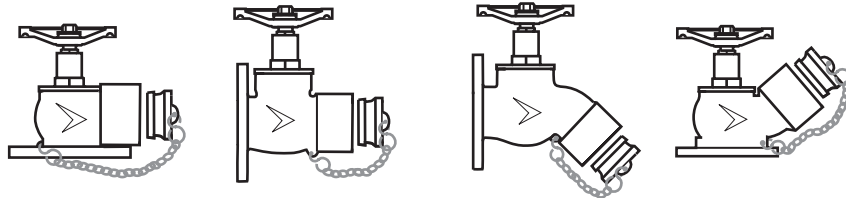

A.) Right Angle B.) Straight Through C.) Bib Nose D.) Oblique

### 2.) INLET

The inlet on a hydrant can be either flanged or threaded. It is more common to have a flanged inlet. There are 3 main types of flanges:- Table D/E, PN16 or ANSI However there are other types but not as common.

#### Flange Inlet

The flange type and size can be identified by measuring the diameter and the P.C.D (Pitch Circle Diameter).

Use the chart and diagram below and overleaf to identify the type.

#### BS10, Table D/E Flange

Size	Flange Dia (A)	P.C.D (B)
1.5"	133mm	98mm
2.0"	152mm	114mm
2.5"	165mm	127mm
3.0"	184mm	146mm

#### Example

Flange dia (A) = 185mm = 2.5" PN16  
P.C.D (B) = 145mm Flanged Inlet

#### BS4504, PN10 & PN16 Flange

Size	Flange Dia (A)	P.C.D (B)
1.5"	150mm	110mm
2.0"	165mm	125mm
2.5"	185mm	145mm
3.0"	200mm	160mm

- A. Flange Outside Diameter
- B. Bolt Circle Diameter (P.C.D)
- C. Number of Holes
- D. Diameter of Holes

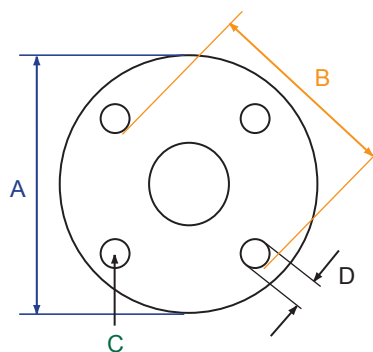

#### ANSI 150 lb FF Flange

Size	Flange Dia (A)	P.C.D (B)
1.5"	127mm	98mm
2.0"	152mm	121mm
2.5"	178mm	140mm
3.0"	191mm	152mm

#### Threaded Inlet

If the hydrant valve has a threaded inlet instead of a flange then you need to know the following:-

- A.) Male or Female Thread ?
- B.) Size ? (e.g 2½" etc)
- C.) Thread Type ? (e.g BSP, NPT etc)

### 3.) OUTLET

The outlet on a hydrant valve can be any international fitting (e.g Storz C, NOR 1 etc) or more commonly a 2½" Instantaneous Female.

Refer to the 'Delta Marine Fire Fighting Equipment Catalogue' to help identify the outlet.

## FLANGE INFORMATION

The flange type and size can be identified by measuring the diameter and the P.C.D (Pitch Circle Diameter). Use the chart below to identify the type.

### **BS10 Table D/E**

Size	Flange Diameter (A)	P.C.D (B)	No. Holes (C)	Dia. of Holes (D)
40mm (1.5")	133mm	98mm	4	14mm
50mm (2.0")	152mm	114mm	4	17mm
65mm (2.5")	165mm	127mm	4	17mm
80mm (3.0")	184mm	146mm	4	17mm

### **BS4504, PN10 & PN16**

Size	Flange Diameter (A)	P.C.D (B)	No. Holes (C)	Dia. of Holes (D)
40mm (1.5")	150mm	110mm	4	18mm
50mm (2.0")	165mm	125mm	4	18mm
65mm (2.5")	185mm	145mm	4	18mm
80mm (3.0")	200mm	160mm	4	18mm

### **ANSI 150lb FF**

Size	Flange Diameter (A)	P.C.D (B)	No. Holes (C)	Dia. of Holes (D)
40mm (1.5")	127mm	98mm	4	16mm
50mm (2.0")	152mm	121mm	4	19mm
65mm (2.5")	178mm	140mm	4	19mm
80mm (3.0")	191mm	152mm	4	19mm

### **JIS 10K**

Size	Flange Diameter (A)	P.C.D (B)	No. Holes (C)	Dia. of Holes (D)
40mm (1.5")	140mm	105mm	4	19mm
50mm (2.0")	155mm	120mm	4	19mm
65mm (2.5")	175mm	140mm	4	19mm
80mm (3.0")	185mm	150mm	8	19mm

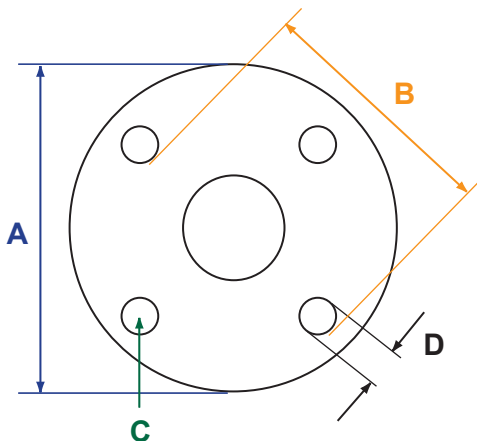

#### Example

Flange dia (A) = 185mm = 2.5" PN16  
P.C.D (B) = 145mm = Flanged Inlet

- A. Flange Outside Diameter
- B. Bolt Circle Diameter (P.C.D)
- C. Number of Holes
- D. Diameter of Holes