

**SURE
STRIPE
6000**

Sure Stripe 6000
AIRLESSCO

The Ultimate Professional Striper

Combine the power to paint or stripe with the heaviest coatings and the sturdiest, easiest to handle chassis available on a pavement striper, and you can stripe rings around the competition! Perfect balance, easy rolling, and room to carry oversized containers, are just a part of owning the most adjustable striper available today.

The SL Slow Stroker™ piston pump is designed for daily contractor use with the heavy coatings typical for striping.

Available options include the R/S Ride & Stripe Honda powered sulky for increased productivity. Combine it with the 1.5 gallon per minute power of the 6000 and you can stripe at up to 12 MPH!

With a SURE STRIPE 6000, you can stripe anything!

SURE STRIPE 6000

Power Honda 5.5 HP with Oil Alert
Pump SL Slow-Stroker™ Piston Type
Annual Usage up to 7500 gallons
Max Pressure 0-3300 PSI (207 Bar)
Max Output 1.5 GPM (5 Litres/min.)
Max Tip 1 gun @ 0.039 inch
2 gun @ 0.028 inch

Shipped Complete:

Part #: 305-001 Model 6000, 1 gun
305-003 Model 6000, 2 guns

Advantages & Features

- Extra large pneumatic tires and tapered wheel bearings.
- Move gun assembly in seconds; left/right, front/back—no tools needed.
- Adjustable height handle attaches to either end of the frame. Allows the striper to have a trailing swivel wheel when desired.
- Rear axle position is adjustable to get perfect balance when using oversized containers.
- Dual swivel wheels counter rotate for easier line up of the striper when doing parking stalls.
- Two-position lock on the front caster, allows the operator to stripe to a wall or to lengthen the wheelbase for increased directional stability when painting long lines.

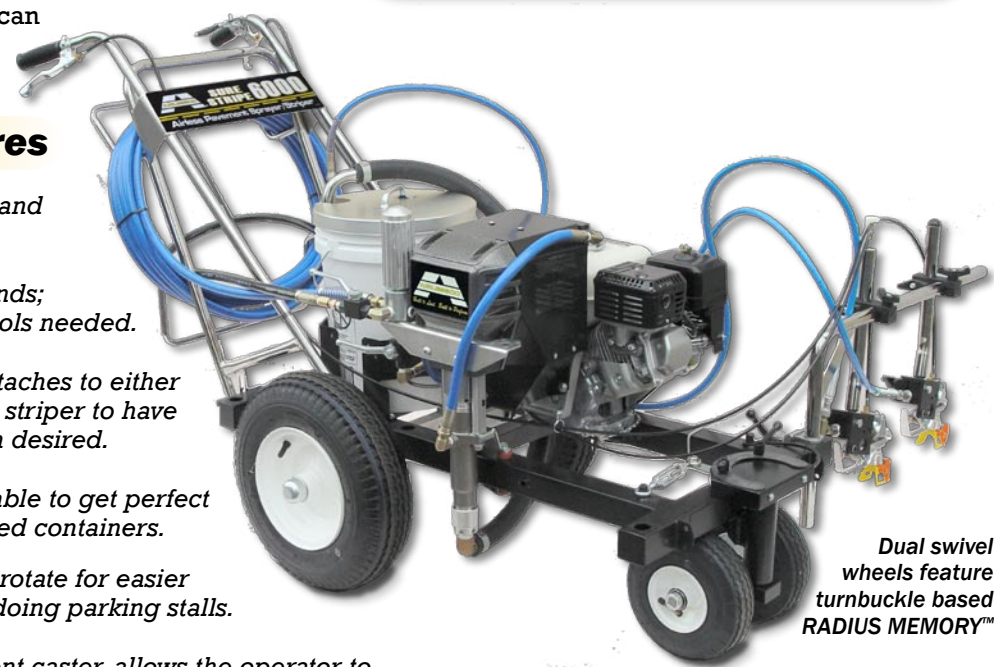

Dual swivel wheels feature turnbuckle based RADIUS MEMORY™

Model 6000 shown with dual guns & standard 50' of 3/4" hose



Stable when Painting Straight Lines



Easy Transition to Curved Lines



Room for Oversized Paint Containers



R/S Ride & Stripe Option Part # 305-265

Flexibility to Cover All Kinds of Painting Jobs



Airlessco equipment can be seen striping soccer fields at the U.S. Olympic Soccer training complex in California, painting buildings, covering graffiti, or routine restriping and painting of parking lots. The flexibility of our striper/sprayers make them a popular choice for:

- School Districts
- Parks & Recreation Depts.
- Contractors
- Universities & Colleges
- Youth Sports Programs



REV-TIP™ Reversible Striping Tip Size Chart

TIP IDENTIFICATION:

1st 3-digits identifies it as a REV-TIP™ for airless line striping (P.N. 562-xxxST).
4th digit is the fan width - the number is half the fan width, e.g., 2 means a 4" wide stripe.
5th and 6th digits are for the orifice size and is measured in thousandths of an inch, e.g., 17 = 0.017 inch - Higher number is a larger tip.

REV-TIP™ for Striping 562-xxxST		STRIPING TIP ORIFICE SIZE (Inches)											
Fan Width (6" from surface)		.009	.011	.013	.015	.017	.019	.021	.023	.025	.027	.031	.035
1-2	25-51			113ST	115ST	117ST							
2-4	51-102				215ST	217ST	219ST	221ST					
4-6	102-152				315ST	317ST	319ST	321ST					
6-8	152-203												
Striping Paint				Oil Base	Oil Base	Latex	Latex	Latex	Latex	Latex	Latex		

REV-TIP™ protected by U.S. Patent No. 6,264,115. Other U.S. & foreign patents applied for.

Striping/Painting Accessories



Gun Extensions

Extends reach for stenciling or painting
12" PN 032-171
18" PN 032-172
36" PN 032-184



Pointer

For easy line-up and striping of long lines.
Part # 136-069

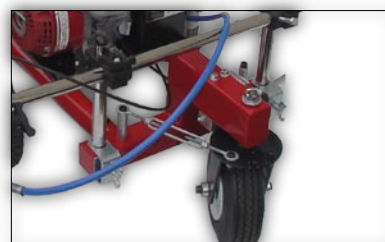

Floating Spray Gun Kit

Upgrades any Airlessco striper to a floating gun mount for ultra consistent width lines on bumpy, uneven surfaces like sports fields. Wheels provide wind protection for spray pattern. Part # 305-349.
(Patent Pending)



Striping Tips

Includes Rev-Tip™ metal seal and O-ring seal
PN 562-xxxST
xxx = Sizes: 113, 115, 117, 215, 217, 219, 221, 315, 317, 319, 321.



Bead Dispensers

Gravity type glass bead dispenser kits.
1 Gun 4" PN 305-174
2 Gun 4" PN 305-175
1 Gun 4-6" PN 305-186
2 Gun 4-6" PN 305-187

AIRLESSCO
www.airlessco.com

All information and specifications in this document are subject to change at any time without notice. Copyright © 2005, Airlessco by Durotech Co. All rights reserved. Form 001-723 Aug 2005
Airlessco by Durotech Co.
5397 Commerce Ave.
Moorpark, CA USA 93021
PHONE (805) 523-0211
FAX (805) 523-1063

**SURE
STRIPE**

**Spray
&
Stripe**

The Affordable Way to Stripe & Spray



Spray & Stripe 3000

Order #	305-229
Engine	Briggs & Stratton 3.5 HP Commercial Gas
Max Pressure	0-2500 PSI (170 Bar)
Max Output	0.62 GPM (2.35 Litres/min.)
Annual Usage	Up to 500 gallons
Max Tip	1 gun @ 0.021"
Weight:	120 lbs. (Ship weight 175 lbs.)
Dimensions:	37"H x 24" W x 65" L

The **Spray & Stripe** series is based on our time tested and contractor proven "LP" piston paint pump delivering up to 2500psi of paint atomizing power! It's used daily by thousands of painting professionals worldwide.

The 3000 is small, compact, easy to use, and quick to clean. Even changing colors is a breeze. Stripe with water-based paints made for traffic lines or athletic fields. A professional spray gun snaps on a multi-position spray arm.

A quick release of the spray gun from its mount lets you paint using stencils, or utilize



Model 3500 has Honda Engine & Front Swivel Wheel!

All the convenience and value of the 3000 with the added durability of a Honda GX100 Commercial engine. Dependable Honda engines are the undisputed choice of professional contractors worldwide. These overhead cam 4-cycle engines set the standard for durability. The 3 HP Honda commercial engine on the 3500 features transistorized magneto ignition and "Oil Alert" to protect your investment. It's perfect for striping contractor use as a 2nd or 3rd color machine. Large 13" wide-track pneumatic tires for smooth tracking on rough pavement or turfgrass surfaces.

LIGHT WEIGHT

Makes the 3500 easy to push on pavement or turf. Handlebar design provides optimal user leverage for precise control keeping lines straight or following curves whether you are striping on a parking lot or bumpy sports field surfaces.



Honda 3 HP 4-cycle Engine with Oil Alert



Swivel front wheel with simple turnbuckle based Radius Memory™

Spray & Stripe 3500

Model #	305-240
Engine:	Honda 3 HP with Oil Alert
Max Pressure	0-2500 PSI (170 Bar)
Max Output	.62 GPM (2.35 Litres/min.)
Annual Usage	Up to 500 gallons
Max Tip	1 gun @ 0.023 inch
Weight:	123 lbs. (Ship weight 178 lbs.)
Dimensions:	37"H x 24" W x 65" L

Durable LP Pump features stainless steel piston and triple life packing system for extended pump life.

the 50' of supplied hose and the spray gun to paint building walls with exterior latex and enamel paints.

Briggs & Stratton 3.5 HP commercial gasoline engine features a ball bearing supported crankshaft for years of reliable service.

Flexibility to do multiple jobs well makes **Spray & Stripe** models popular with cities, school districts, and sports programs for striping parking lot or athletic field striping, and for use as a mobile airless spraying station. They are perfect for painting fences, buildings, and covering graffiti.



The Professional Airless Striper That Sets New Standards for Value!

The 4000 is the compact piston pump striper that delivers the professional results and range of features needed by pavement striping contractors—and it's an incredible value!

It's based on our proven LP Piston Pump used daily by thousands of painting contractors. The large one-piece piston along with Airlessco's patented triple-life packing system results in reduced maintenance, lower operating costs, and longer equipment life. The clutch actuated paint system features an electronic pressure control system.

The 4000 is powered by a dependable Honda GX series commercial OHV 4-cycle engine. It operates at low speeds for minimal vibration and noise levels. It's built on our compact square tube frame that's lightweight yet very strong. It's easy to use, and quick to clean. Designed in balance & light weight make it ideal for one-man operation. Foot operated parking brake holds the machine on inclines.

Our 008 Silver spray gun mounts on any corner, has a quick release for painting parking curbs or pavement using stencils. It features a tungsten carbide ball and seat, the "No Drips" REV-GUARD™ base, and our patented REV-TIP™ reversible tips that clear clogs literally in a snap.

SURE STRIPE 4000

Power	Honda 4 HP with oil alert
Pump	"LP" Piston, Triple-Life Packings externally adjustable
Annual Usage	up to 2500 gallons
Max Pressure	0-3000 PSI
Max Output	.8 GPM, 3 Liters/min.
Max Tip Size	.029"
Frame	Welded box steel, powder coat finish
Gun Mount	Relocatable to any corner of frame

Shipped Complete:

Part # 305-227 SURE STRIPE 4000 with spray gun and 50' of hose.



Built to Perform... Built to Last

Handlebars adjust up and down & mount at either end



Bucket holder adjusts for oversized containers

Dependable Honda OHV engine

"LP" Piston Power Airless Pump

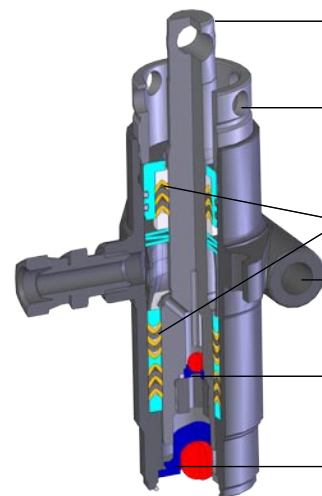

Super hardened, stainless steel piston. Large diameter means fewer cycles per gallon, reducing wear.

Packing tension on upper and lower packings adjusts from outside the pump. Extends packing life, saving repair costs & reducing down time.

Patented Triple-Life Packing System.

1-piece pump body with no seals to leak or wear-Lifetime Warranty!

Tungsten carbide seats give increased gallonage & longer life.

Ball and seat life is extended by self-centering, high-flow ball cage for positive valve operation.

Front swivel wheel with turnbuckle adjustable RADIUS MEMORY™

Big SL "Slow Stroker"™ Piston Power Contractor Striper in a Compact Frame



SURE STRIPE 4500

Power	Honda 5.5 HP with Oil Alert
Pump	SL "Slow Stroker" Piston type Triple-Life packings externally adjustable
Annual Usage	up to 7500 gallons
Max Pressure	0-3300 PSI (207 Bar)
Max Output	1.5 GPM (5 Litres/min.)
Max Tip	1 gun @ 0.035" 1 x 12" (30cm) line. 2 gun @ 0.021" 2 x 12" (30cm) lines.
Frame	Welded box steel, powder coat finish

Shipped Complete:

Part # 305-206 Sure Stripe 4500 with 1 gun
305-176-99 Optional Second Gun Kit

The compact convenience and flexibility built into the 4000 frame with the added advantage of the two-gun power and legendary durability of Airlessco's SL Slow-Stroker™ paint pump. The SL pump has a large one-piece stainless steel piston, stainless pump body and check balls. Extra large tungsten carbide reversible seats, along with our patented triple-life packing system results in reduced maintenance, lower operating costs, and longer equipment life.

This pump has the power to spray a wide variety of pavement and athletic field striping paints; with an available second gun that lets you stripe lines up to 24" (60cm) wide.

Popular features include a gun mount system that allows you to quickly move guns to any corner of the machine. Handlebars that can be mounted at either end of the frame, with quickly adjustable height to suit operator.

The front wheel on the 4500 can remain locked for straight lines, or be operator released from the handlebars, allowing the front wheel to swivel when painting curves or circles. Inexpensive adjustable turnbuckles provide RADIUS MEMORY™ for consistent striping of arcs and circles.

Powder coated frame, anodized and chrome plated heavy duty hardware are evidence this equipment is "Built to Last" through many years of daily professional use.

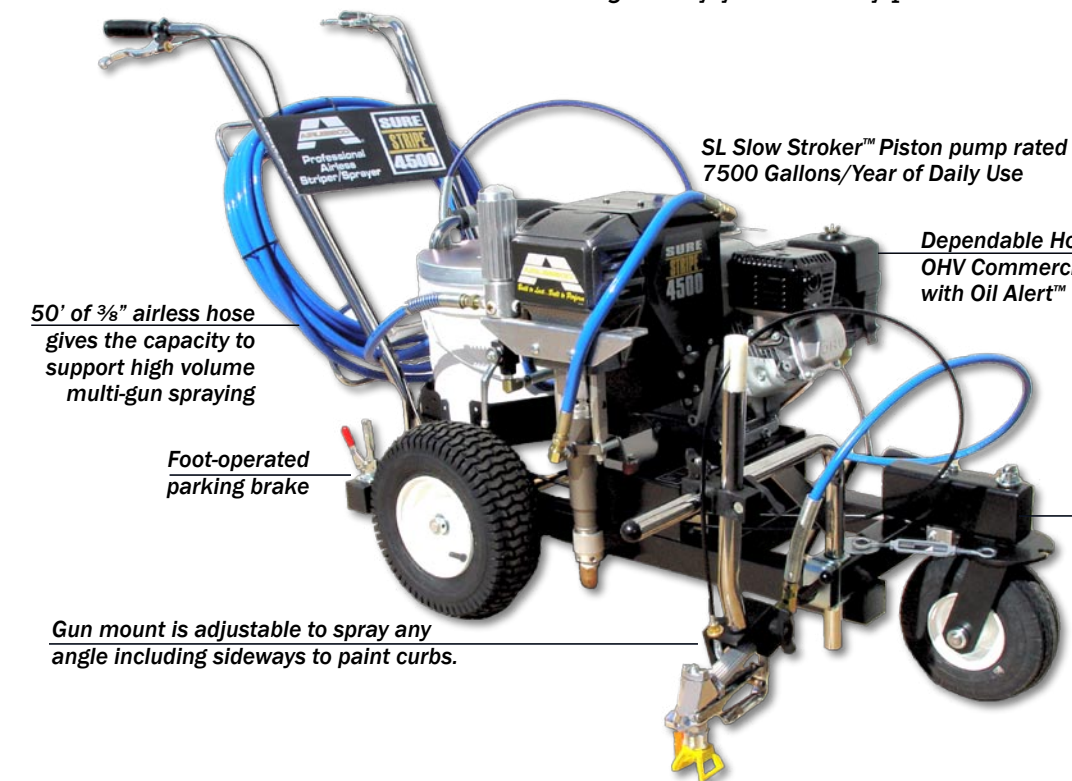

SL Slow Stroker™ Piston pump rated for 7500 Gallons/Year of Daily Use

Dependable Honda 5.5 HP OHV Commercial Engine with Oil Alert™

50' of 3/8" airless hose gives the capacity to support high volume multi-gun spraying

Foot-operated parking brake

Gun mount is adjustable to spray any angle including sideways to paint curbs.

Front swivel wheel with turnbuckle adjustable RADIUS MEMORY™