



Chopper Fan



The chopper fan is a purpose designed, heavy duty, material-handling fan fitted with hardened steel cutting blades.

Its function is to provide the required conveying air volume and pressure to efficiently transport the waste material through the system from the production machines to the material separator unit.

It has a reinforced, dynamically balanced, self-cleaning steel impeller, proportioned for maximum aerodynamic efficiency but with the added capability to shred or chop any large pieces of waste.

The chopper fan is equipped with a heavy duty, adjustable spring loaded inlet assembly ensuring the correct chopping action occurs during operation and to provide protection from surge loads.

The fan is driven from a compact overhead or base mounted drive motor arrangement (depending on size) via a variable speed v-belt transmission, all assembled and tested prior to delivery.

Features:

- Replaceable long life hardened steel cutting blades
- Non-clogging wear resistant impeller
- Adjustable inlet assembly for cutting gap adjustment
- Positive cutting action
- Impeller statically and dynamically balanced for smooth vibration resistant running
- Double row spherical roller bearing assembly for long life
- Available with automatic bearing lubricators
- Available with energy efficient motor options
- Heavy duty durable construction

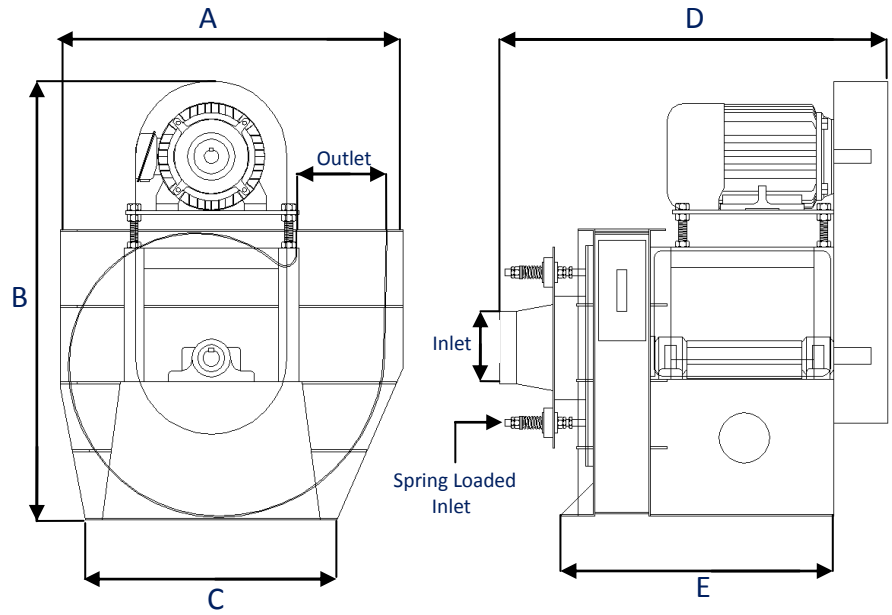
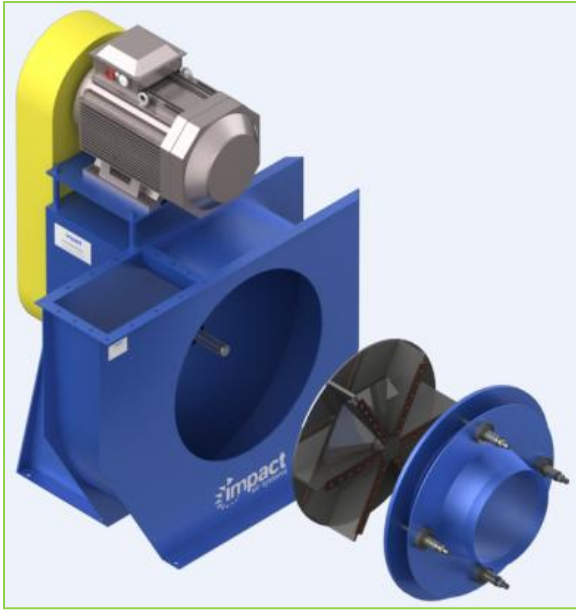

Chopper fan Selection Table

Model Ref	20		25		30		40		45		55	
Inlet Diameter	200		250		300		400		450		550	
Outlet Dimensions	160 x 265		190 x 320		215 x 360		300 x 480		340 x 525		400 x 600	
Impeller Diameter	580		680		780		780		880		980	
Max RPM	2600		2500		2300		2100		1950		1800	
Min Motor Size	4kW		5.5kW		7.5kW		7.5kW		11kW		11kW	
Weigh in KGs	320		380		450		480		600		720	
Motor Arrangement	Top	Base	Top	Base	Top	Base	Top	Base	Top	Base	Top	Base
Dimension A	1020	n/a	1170	2140	1325	2250	1420	2330	1570	2455	1750	2435
Dimension B	1302	n/a	1512	1127	1627	1262	1757	1327	1852	1467	2032	1499
Dimension C	750	n/a	850	1920	900	1970	950	2000	1000	2070	1100	2000
Dimension D	1154	n/a	1184	1224	1209	1249	1334	1334	1334	1374	1416	1516
Dimension E	810	n/a	840	1205	865	1230	950	1315	990	1355	1050	1372

