

**flexium<sup>+</sup>**

**CNC SYSTEM 2015/2016**



[www.num.com](http://www.num.com)

**NUM**   
CNC HighEnd Applications

# Flexium+ CNC System

Edition 2015/2016  
Table of Content



Introduction	1
Flexium+ CNC System	2
Operator Panels and Industrial PC	3
Flexium+ NCK	4
NUM Safe PLC and NUM I/Os	5
NUM Motors	6
Motor / Drive Associations	7
NUMDrive X	8
NUM EtherCAT Terminals	9
Cables / Accessories	10
Flexium+ Configurations	11
General Information	12





	Page
<b>Introduction</b>	<b>7</b>
<b>Flexium+ CNC System</b>	<b>9</b>
Flexium+ System Overview	12
User / Customer Benefits	12
General Characteristics	14
Components	15
Flexium+ and Safety	25
System Functions	27
General System Composition	27
CNC Functions	28
Flexium+ PC Panels	42
Flexium+ HMI Functions	43
Flexium 3D	45
Flexium Tools Functions	46
Flexium+ PLC Functions	49
NUMSafe	50
NUMDrive X Functions	53
Standard Functions	53
Optional Functions	54
Standard and Optional Safety Functions	55
Flexium+ Options Grid Summary Table	56
Basic Characteristics	57
Machine Configuration	58
Axes, Spindle and Machining Functions	59
Programming, Tools and Operation	60
PLC Functions	61
Options Packages	62
Applications	64
HMI Functions	65
NUMDrive X Functions	66
<b>Operator Panels and Industrial PC</b>	<b>69</b>
FS192i Operator Panels with Integrated iPC	71
Technical Characteristics	73
Outlines	74
Ordering Codes	77
FS153i Operator Panels with Integrated iPC	78
User Interface Options	79
Technical Characteristics	80
Outlines	81
Ordering Codes	83
FS192L, FS153 and FS122 Operator Panels	84
FS192L Operator Panel	85
Technical Characteristics	86
Outlines	87
Ordering Code	90
FS153 Operator Panels	91
User Interface Options	91
Technical Characteristics	92
Outlines	93
Ordering Codes	95
FS122 Operator Panels	96
User Interface Options	96
Technical Characteristics	97
Outlines	98
Ordering Codes	99
MP05 Machine Panel	100
Outlines	101
Ordering Code	102
MP04 Machine Panel	103
Options	104
Technical Characteristics	105
Outlines	106
Ordering Codes	107

# Flexium+ CNC System

Edition 2015/2016  
Table of Content



	Page
Industrial Box PC	108
Technical Characteristics	111
Outlines	112
Ordering Codes	114
nPad	115
Product Overview	116
Technical Characteristics	117
Outlines	119
Ordering Codes	120
HBA-X Portable Handwheel	121
Technical Characteristics	123
Outlines	124
Ordering Codes	125
<b>Flexium+ NCK</b>	<b>127</b>
Description	129
General Characteristics	131
Dimensions and Ordering Code	132
<b>NUMSafe PLC and Safe I/Os</b>	<b>133</b>
CTMP6900 - NUMSafe PLC	135
Technical Characteristics	136
Outlines and Ordering Code	137
CTMS1904 - NUMSafe Digital Inputs Terminal	138
Technical Characteristics	139
Outlines and Ordering Code	140
CTMS2904 - NUMSafe Digital Outputs Terminal	141
Technical Characteristics	142
Outlines and Ordering Code	143
<b>NUM Motors</b>	<b>145</b>
Overview and Product Positioning	147
BHX & SHX Servomotors	149
Characteristics	149
BHX - Ordering Codes	150
SHX - Ordering Codes	151
BPX & SPX Servomotors	152
Characteristics	152
BPX - Ordering Codes	153
SPX - Ordering Codes	154
BHX, SHX, BPX & SPX Servomotors	155
BHX & BPX Outlines	155
SHX & SPX Outlines	156
BPX Outlines	157
BPH Servomotors	158
General Characteristics	158
Technical Characteristics	159
Ordering Codes	160
BPG Servomotors	161
Characteristics	161
Ordering Codes	162
BPH & BPG Servomotors	163
BPH & BPG Outlines	163
BHL Servomotors	164
Characteristics	164
Ordering Codes	165
BHL Outlines	166
AMS & IM Spindle Motors	167
General Characteristics	167
Technical Characteristics	168
AMS Ordering Codes	169
IM Ordering Codes	170
AMS Outlines	171
AMS & IM Outlines	172
Encoder Characteristics	173



	Page
Custom Motors	174
<b>Motor/Drive Associations</b>	<b>175</b>
Servo Motors	177
Association of BHX & SHX Motors with NUMDrive X	177
Association of BPX & SPX Motors with NUMDrive X	178
Association of BPH Motors with NUMDrive X	179
Association of BPG Motors with NUMDrive X	181
Association of BHL Motors with NUMDrive X	183
Spindle Motors	184
General Description	184
Association of AMS and IM Spindle Motors with NUMDrive X	185
<b>NUMDrive X</b>	<b>187</b>
Description	189
Power Supply Characteristics	191
Servodrive Interoperability	193
Servodrive Technical Characteristics	195
Servo Drive and Power Supply	197
Outlines Size 1 and 2	197
Outlines Size 4	198
Outlines Size 6	199
Power Supply Ordering Code	200
Servo Drive Ordering Code	201
<b>NUM EtherCAT Terminals</b>	<b>203</b>
General Characteristics	205
Gateways and Terminals	207
Ordering Code & Example	208
Technical Data and System Structure	209
<b>Cables / Accessories</b>	<b>211</b>
Overview	213
System Cables	218
System Connectors	220
NUMDrive X Connectors and Adapters	221
NUMDrive X Kits	223
Miscellaneous	226
NUMDrive X Line Filters	227
NUMDrive X Line Chokes	230
NUMDrive X Braking Resistor	234
Auto-Transformer	238
Motor Cables and Connectors	239
<b>Flexium+ Configurations</b>	<b>255</b>
Standard Configuration Flexium+ 6 and Flexium+ 8 System	257
Standard Configuration of Flexium+ 68 System	258
Multi-Panel Configuration of Flexium+	259
Flexium+ Configuration for Office PC	260
Flexium+ Configuration with Foreign Panel	261
<b>General Information</b>	<b>263</b>
Adresses / Contacts of all NUM Subsidiaries	265
Regulations	268

# Flexium+ CNC System



# Introduction

NUM, a World Player in Machine Automation

## CNC Power Engineering - Always on the move

NUM supplies complete CNC solutions for the automation of production machines in special market segments and for customers with special requirements.

The high flexibility of our systems, combined with the extensive application knowledge and expertise of our innovative engineering team, allow us to tailor solutions to exactly match the needs of our partners – machine manufacturers and other members of the machine industry.

**Mission Statement: NUM CNC solutions provide machine builders with a competitive advantage.**

Ever since launching its first CNC system in 1961, NUM has continued to develop and is now an independent European company with growing international activities. With our own sales and support facilities in all key regions we are able to support our machine building customers globally. We also have an extensive network of trained and certified after-sales service partners, so end-users all around the world have fast and easy access to service for machines based on NUM systems.

The Flexium CNC system is NUM's biggest success to date – in the few years since its launch it has been installed on a huge number of machines worldwide. So machine builders and end-users can feel very comfortable and secure that they are in good company when choosing NUM's Flexium platform.

NUM has operated at the leading edge of technology for more than 50 years, and has pioneered some major developments in the market. True to our history, with the Flexium+ system we have again set new standards.

Building on the proven concept of the Flexium system, we have added new functionality and further enhanced performance, including a new state-of-the-art security concept and programmable touch-sensitive operator panels.

Like us on Facebook, follow us on Twitter or visit our website for the latest information on NUM CNC Applications:

 [facebook.com/NUM.CNC.Applications](https://www.facebook.com/NUM.CNC.Applications)

 [twitter.com/NUM\\_CNC](https://twitter.com/NUM_CNC)

 [www.num.com](http://www.num.com)

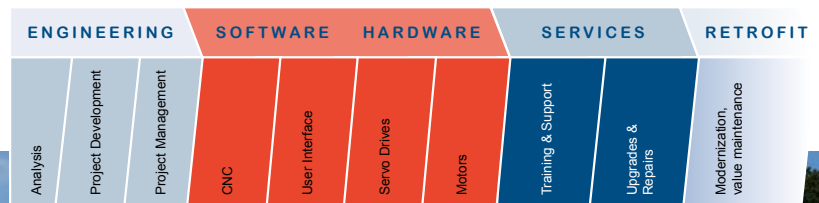

## Accompaniment and support during the entire product life cycle

When you select a system and a solution from NUM, you are making a long-term investment. As your partner, we participate throughout the entire process: from the conception of the idea to its execution, from on-site customer service to retrofitting years later, giving new life to quality used machines.

NUM supports you and your projects to achieve the best results for your company and its customers. The goal of our cooperation is always the same: to help you create the best-possible solution for your project.

All of our solutions are based on perfectly integrated products such as CNC systems, servo drives and motors from our own extensive range. Partnership with our customers is maintained throughout the evaluation, project and installation phases by means of training courses, support and service centres, and continues after commissioning. We make a point of advising our customers with specific know-how from our experts.

When you choose NUM, you are also choosing customer service which will continue to serve you just like new long after you have made your initial investment – even after 20 years, we still serve on-site. Our specialists can extend the life of your quality older machines with NUM Retrofits.

NUM is committed to transferring its knowledge on a regular basis. CNC knowledge and special production expertise, as well as drive and application techniques, are the subjects of the training programs taught by our specialists.



### A Compact Scalable CNC System

Flexium<sup>+</sup> CNC is a key element of the solutions and systems of NUM.

The Flexium<sup>+</sup> system is easily scalable and can be fully adapted to the needs of customers. Available in three configurations Flexium<sup>+</sup> 6, Flexium<sup>+</sup> 8 and Flexium<sup>+</sup> 68, each equipped with specific functions and function packages, it can be tailored to the particular application.

To create an optimal CNC, just pick the platform best suited to the application and the machine, and include the appropriate options, either individually or as technology packages (turning, milling, woodworking, etc.).

#### Flexium<sup>+</sup> 6

- CNC with choice of kinematic structure: milling or turning
- CNC for up to 4 axes and 1 spindle
- One CNC channel
- Interpolates up to 4 axes simultaneously

#### Flexium<sup>+</sup> 8

- For CNC for up to 5 axes or 4 axes and 1 spindle.
- One channel is standard, a second is optionally available
- Interpolates up to 4 axes simultaneously
- Various options and technology packages available

#### Flexium<sup>+</sup> 68

- CNC for 5 axes + spindles in standard version, up to 32 axes/spindles as an option (with a max of two analog)
- One channel is standard. 2, 4, 6 or 8 channels as an option
- Interpolates 4 axes per channel as standard, up to 9 interpolated axes per channel as an option
- Various technology packages and interpolation functions are available as options
- Possibility to create Multi-NCK configuration (option), to extend the system to more than 200 interpolated axes and 40 channels

### Open, User-Friendly and Ergonomic, Guaranteed Efficiency

NUM systems are known for their high degree of flexibility and adaptability to various configurations. This is achieved primarily by powerful functions and operator panels with dedicated Human Machine Interfaces (Flexium<sup>+</sup> HMI).

#### CNC Functions

Flexium<sup>+</sup> systems have high-level CNC functions and high performance servo drive algorithms that can be further tailored thanks to the well known dynamic operators (ISO or C) for the CNC and their new counterpart on Drive: The Drive embedded macros. All this allowing the productivity of all types of machines to be maximized.

### Operator panels with an integrated industrial PC

Depending on the application, several power levels, sizes and touch functionality can be selected. Reliable and well suited to their usage, they form an ideal partnership with the Flexium<sup>+</sup> NCK.

For remote control of machines, the nPad Mobile Operator Panel provides certified safety over wireless functions.

#### Human Machine Interface

OEMs can use or adapt the Flexium<sup>+</sup> HMI, or develop their own interface using widely available off-the-shelf tools:

HTML editor, Visual Basic, C#, C++, etc.

#### NUM Motors: Perfect for all Applications

NUM produces a comprehensive range of motors, all offering excellent volume/performance ratios and great dynamics, to suit almost any application. In combination with NUM drives, these motors provide excellent smoothness even at very low rotational speeds, and can be easily integrated into machines.

#### Brushless Axis Motors

Seven different ranges of NUM brushless axis motors, spanning continuous torque outputs from 0.5 to 180 Nm, make it easy to match application needs very precisely. The new BHX and BPX motors have an advantageous price/performance ratio and are available in medium and high inertia versions to suit different machine requirements, while the new SHX and SPX motors use an innovative digital interface that eliminates the need for a separate encoder cable.

#### Spindle Motors

The AMS and IM series of motors combine very smooth low speed operation with extremely fast and accurate positioning capabilities, making them ideal for C axis applications as well as spindle indexing. The range covers continuous power outputs from 3.7 to 55 kW.

#### Motorspindle®

The active parts of the motor are integrated directly in the spindle, ensuring increased machine rigidity and quieter operation. NUM has the capacity to develop special versions of these motors to suit customers' requirements.

#### NUMDrive X: Compact Precision and Dynamics

Based on the latest technology, NUMDrive X servo drives are the ideal partner for the powerful Flexium<sup>+</sup> CNC. The drives' modular, compact design and low power consumption corresponds ideally to the needs of modern machine control systems.

One distinguishing feature of all NUMDrive X servo drives is their high power density. The drives pack an enormous amount of computing and output power into a very small module and have some of the highest power/space ratios of any units on the market. A wide range of power modules and scalable control units, available in Mono-Axis and Bi-Axis versions, enables the best technical solution to be implemented economically. For maximum precision, speed and cost-effectiveness, the performance of NUMDrive X servo drives can be tailored to suit particular machines and applications.

NUMDrive X servo drives also provide support for NUM's state-of-the-art Functional Safety Over Ethernet (FSOE) concept.

	Page
<b>Flexium+ System Overview</b>	<b>12</b>
User / Customer Benefits	12
General Characteristics	14
Components	15
Flexium+ and Safety	25
<b>System Functions</b>	<b>27</b>
General System Composition	27
CNC Functions	28
Flexium+ PC Panels	42
Flexium+ HMI Functions	43
Flexium 3D	45
Flexium Tools Functions	46
Flexium+ PLC Functions	49
NUMSafe	50
<b>NUMDrive X Functions</b>	<b>53</b>
Standard Functions	53
Optional Functions	54
Standard and Optional Safety Functions	55
<b>Flexium+ Options Grid Summary Table</b>	<b>56</b>
Basic Characteristics	57
Machine Configuration	58
Axes, Spindle and Machining Functions	59
Programming, Tools and Operation	60
PLC Functions	61
Options Packages	62
Applications	64
HMI Functions	65
NUMDrive X Functions	66



### A New Platform

Flexium+ builds on the success of NUM's Flexium system to advance CNC to a new level. It combines all the power, flexibility and user-friendliness NUM's products are renowned for, with additional state of the art functionality and a completely new hardware and software platform.

The outstanding success of Flexium with over 10,000 applications completed in a short space of time paved the way for development of Flexium+. We took the best components, kept those elements behind the success of our previous CNCs, such as scalability, flexibility, unique CNC functions, standardized interfaces and PLC programming, then renovated and improved the complete system. Flexium+ has new and enhanced features, new panels, a new HMI, an enhanced servo bus, enhanced drives and simplified connectivity – all within a completely new safety-related architecture.

To provide optimum cost/performance ratios, Flexium+ exists in three configuration levels

- Flexium+ 6
- Flexium+ 8
- Flexium+ 68

The compact dimensions of all components of the Flexium+ system are in line with NUM's green approach regarding limited energy requirements, smaller cabinet dimensions, reduced power dissipation, and minimal weight and packaging, while assuring the best performance.

Latest generation processors powering intelligent and evolutionary hardware ensure return on investment and a long system life, in line with NUM's philosophy.

Increased CNC functionality offers improved flexibility, scalability and accuracy. In particular, we have extended the concept of axis or spindle to allow control of up to 32 spindles per NCK unit (NCK for NC Kernel) and make spindle/axis commutation even easier. We have also improved the internal computing resolution, increased the digital servo bus speed, and much more. The ability to link several NCKs together in a global configuration has of course been maintained, enabling, for example, the control of large transfer systems with more than 200 interpolating axes.

Thanks to enhanced algorithms, the data are processed internally with a higher accuracy. This feature, named 'Nano interpolation', provides much more precise control of travel, speed and acceleration.

The Flexium+ system encompasses the NUMDrive X digital drives controlled via up to three RJ45 ports, allowing for easily wired distributed drive sets on the machine. In addition to the digital links, two analog interfaces are provided for special requirements.

The PLC itself complies with the IEC 61131-3 standard and communicates via efficient standardized interfaces like EtherCAT for fast exchanges, as well as providing the opportunity to build a safe machine environment in compliance with the standards EN 13849-1 up to PL e and EN61800-5-2 up to SIL 3.

The human-machine interface is provided via PC panels, including a revolutionary 19" unit and companion machine panel, all running modern fully redesigned HMI software. There is a choice of machine panels and portable units, and the renowned Flexium 3D simulation package rounds out the portfolio.

The single development environment provides different access levels for machine integration, setup and maintenance.



---

### Safety

A key distinguishing feature of Flexium+ is its new safety architecture, NUMSafe.

In short, a safe PLC is intimately integrated in the current one and, using FSOE<sup>1</sup> protocol, it communicates with safe inputs and safe outputs, as well as with the new NUMDrive X where the safe motion monitoring functions are implemented and executed.

NUMDrive X, featuring the new SAMX functional safety board is a key component of this solution. It maintains all of the superlative and well known characteristics of NUMDrive C – performance, scalability, modularity, reliability ...- and drives them even further.

The programming environment is provided for both “safety related” and “non safety related” logic.

---

### Flexibility

This recognized characteristic of NUM products has now been advanced even further. With Flexium+ the notion of axis or spindle has been totally revisited. Any of the 32 devices connected can be alternatively an axis or a spindle. This makes spindle/ C axis commutation even easier but more importantly it opens the door towards new possibilities, sophisticated transfer machines being one among many.

As a direct consequence a single Flexium+ CNC is now able to control up to 32 spindles. Among the four spindles of each channel one will be the main on which all advanced functions (CSS, Threading ...) will be performed, the three others being declared as auxiliaries. They are controllable in speed, direction and indexing. And of course, exchanging spindles or axes between channels or declaring a new main or auxiliary spindle is just an M code away.

---

### Productivity

Among other new features, the computing power has been more than doubled, resolution and bandwidths increased significantly, with more and faster inputs and outputs made available. Unified firmware for both Mono-axis and Bi-axis drives makes version management even easier.

Last but not least, thanks to an innovative communication protocol that handles encoder power and data on just two wires, the encoder cable has become unnecessary and therefore was completely removed. Motors and drives can now be linked with a single cable, saving time and money.

With Flexium+, Safety now also means simplified programming, simplified wiring, simplified setup plus new functions.

<sup>1</sup> Fail Safe Over EtherCAT

# Flexium+ CNC System

## Flexium+ System Overview

### Flexium+ 6, Flexium+ 8

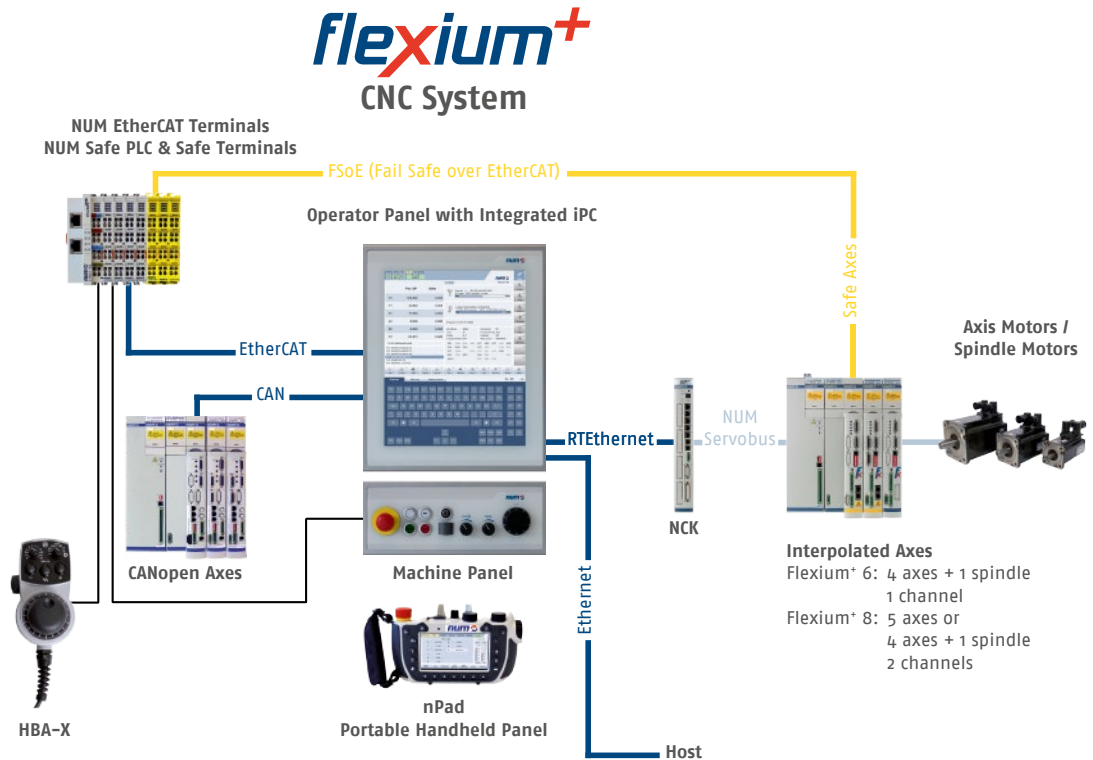

2

### Flexium+ 68

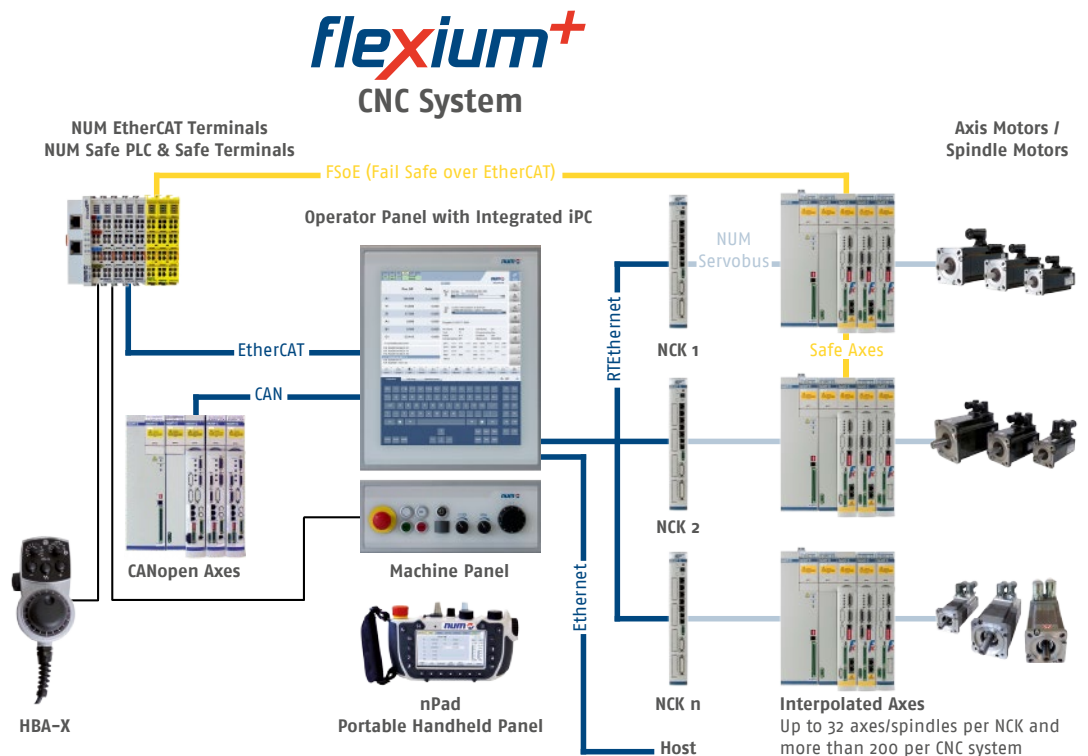

---

### Axes Structure

Flexium+ provides up to eight <sup>1</sup> channels, each able to handle up to nine axes, a main spindle and 3 auxiliary spindles. Each channel runs its own part program at its own pace, with the possibility of synchronization when necessary. Thanks to the advanced programming function, this structure offers numerous possibilities, including the ability to pass control of one or more axes from one channel to another on the fly. Moreover, the different channels can also function totally independently. This is almost like having several NCKs.

---

### Speed and Accuracy

There is no longer any need to make compromises between extended travel and high resolution, or between fast traverse rates and high accuracy. New algorithms have been implemented to push the limits in every direction. Detailed technical characteristics are described in this catalog.

---

### Axes Control

Enhanced acceleration algorithms allow, thanks to the increased resolution, fine tuning of the jerk value for optimal block transitions while limiting mechanical stress.

The different tools to optimize and check the servo response are integrated in the Flexium Tools development package. In close association with the digital drives, they provide monitoring of the drives' internal values, oscilloscopes to check all kinds of responses, a Ballbar <sup>2</sup> function, Contour accuracy checking to verify machine reaction in a specific part of the machining cycle, and many other functions.

---

### Programming

To control these new functions the part program structure has been reviewed, taking advantage of the 40 MB available.

Block numbering has been extended, and enhanced search capabilities have been provided. Direct editing facilities, in conjunction with backtrack and resume functions help interaction when necessary on long machining operations.

Emergency retract, either manually or automatically generated, is an important feature to protect people and material, should anything go wrong.

More details about the programming features are given in Chapter 4.

---

### Machining Packages

The range of specific machining packages or functions is expanded. In addition to the current Turning, Milling, Grinding (OD or surface), Gear hobbing, Shaping, etc, NUM is introducing new jet cutting functions. These include a 'tilted nozzle management' function that automatically compensates for the conical shape of the beam.

And much more:

The following pages will describe the other components of the system. It is however not possible to define in a few pages all the advantages Flexium+ could bring you. Don't hesitate to contact us - we will be happy to demonstrate our products in more detail so that you can understand why NUM, your partner, is truly a High End CNC application provider.

<sup>1</sup> One Channel up to 4 axes and 1 spindle for Flexium+ 6  
Up to 2 channels and up to 5 axes, or 4 axes and 1 spindle, for Flexium+ 8

<sup>2</sup> Ballbar function is intended to measure and therefore correct trajectory error (sticking, quadrant transition, radius) in circular interpolation

# Flexium+ CNC System

## Flexium+ System Overview Components

### NCK

Flexium+ NCK is the heart of a system. In a compact design compatible in size with the NUMDrive X components it packs a powerful engine, up to 40 MB of user memory, the connectivity for up to 32 digital axes or spindles and the PLC link, all delivered on standard RJ45 ports.

Additional Ethernet and clock synchronization ports for multi NCK operation, two analog axis ports, two probing inputs as well as sixteen digital inputs, sixteen digital outputs all with direct part program access, four analog inputs and two analog outputs complete this unit.

Powered by a 24VDC 1A supply, the NCK is identical for all versions of Flexium+.

Efficient hardware is just one side of the solution; the reengineered Flexium+ firmware also provides new and innovative features. Chapter 4 describes the firmware and the options in more detail.



### Panels FS122, FS153i, FS192i

Flexium+ PC panels (FS family) provide both the human machine interface (HMI) and the PLC function. Different versions of panels are available including a revolutionary 19" unit.

This new 19" unit (FS192i) operating panel provides a durable, modern front end for machine control. It has an IP65 degree of protection at the front, and IP20 at the rear. High-quality 4 mm hardened glass protects the front, without introducing any disturbing reflections. A narrow brushed aluminum frame with rounded edges provides complete side protection for the glass and multi-touch sensor. The FS192i presents a modern face to the world. For improved ergonomics comfort, NUM has completely revised the Flexium+ HMI panel software, in line with its design guidelines, to accommodate dual touch gestures such as 'Drag & Drop', 'Wipe', 'Zoom' and 'Rotate'. Of course, a mouse and keyboard remain available for data input and control. All HMI context levels have been adjusted to a new design for improved usability and operator convenience.

For users who want to run their HMI on a different PC, NUM offers the Box PC unit dedicated for the PLC <sup>1</sup> function only.



<sup>1</sup> The PLC function is mandatory, therefore a Flexium+ configuration must include either one FSxxx or a Box PC

# Flexium+ CNC System

## Flexium+ System Overview Components

In addition to the active panels shown on the previous page, NUM offers a number of companion products for human-machine interaction.

---

### MP04

This configurable machine panel includes 63 keys with LEDs, 2 potentiometers, an emergency stop pushbutton, a three position key-switch and an optional hand-wheel. Interfaced on CANopen this panel also includes on the back 10 digital inputs and 12 digital outputs. Design fits with the FS153 family.

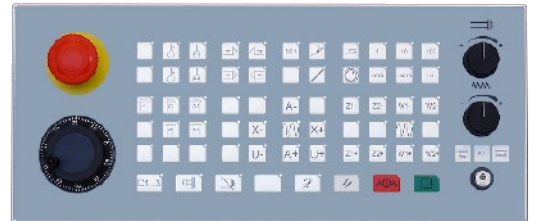

---

### MP05

An ideal companion for the FS192i 19" operator panel and its virtual keyboards, the MP05 is fitted with 4 rugged buttons, two overrides, an emergency stop pushbutton, a handwheel and a USB interface.



---

### nPad

Fitted with a 5" display and a dedicated but customizable HMI, the nPad provides 19 soft-keys, 2 override potentiometers, a handwheel, and a 16 position selector, as well as emergency stop and dead-man's buttons. It is available in two versions: wired and certified wireless.



---

### HBA Portable Handwheel

Suited for manual control of the axes, this unit combines an electronic handwheel, two selectors, three pushbuttons and a three-step dead-man's button, in an ergonomic enclosure.

Detailed characteristics of the panels are contained in Chapter 3.



# Flexium+ CNC System

## Flexium+ System Overview Components

### Flexium+ HMI

Running on the Flexium+ panel and/or other PCs connected for multi-panel operations, Flexium+ HMI, organized in several contexts, is a very intuitive interface for interacting with the machine. Function keys located on the bottom and right side of the screen allow direct and quick access to all relevant functions and menus.

Flexibility is one distinguishing feature of the Flexium+ HMI. In the standard configuration, it already provides three 'connectors' for adding custom pages. Should the need arise for deeper customization Flexium+ HMI can be freely customized to the requirements of the user and the application, using tools such as HTML, Java, Visual Basic, Delphi, C, and C++ etc. This allows full exploitation of the machine's strong points, logically modeling the applications and, consequently, increasing the efficiency of the machining processes.

Flexium+ HMI software is a part of the Flexium Suite; it is pre-installed on the PC-panels, delivered on a USB stick for backup and can be downloaded from the Internet for further updates. The URL address, user name and the password will be supplied on hardware delivery.

Taking advantage of the 19" vertical display, Flexium+ HMI provides three virtual keyboards for

- Machine control (virtual machine panel)
- Editing (virtual keyboard)
- ISO programming (dedicated panel)

The screenshot displays the Flexium+ HMI interface with the following components:

- Status Bar:** Shows machine status (START, STOP, M02, AUTO, CNC?, FDRHD) and HMI version (HMI: 8). It also includes channel status (CNC0, Ch00, VALID, Machine00) and (Mch0, Machine0).
- Machine Mode:** Set to 'Prod'.
- Machine Parameters:**
  - Spindle: 1 M5 M9 M48 M62 M66
  - S 0 rpm \* 50% current : 0 rpm
  - Progress bar: 50% to 120%
- Interpolation Settings:**
  - Circular interpolation CCW
  - F 2945.000 mm/min \* 120% = 3534.000 mm/min
  - Progress bar: 0% to 120%
- Program Data:**
  - Program %1234 23
  - NC Block N0
  - Tool T13
  - Plane X-Y
  - Compensation Off
  - Corrector D13
  - Programming Abs
  - Coolant Off
- Coordinate Table:**

	Pos. OP	Delta
X1	-2.636	0.384
Y1	-1.980	-0.471
Z1	0.100	0.000
- Program List:**
  - %1234
  - 23 G3 X-2.2514 Y-2.4509 I-.8333 J-.902
  - 24 G3 X3.1889 Y-.9527 I.0001 J-.0002
  - 25 G3 X-.5666 Y3.2796 I0. J0.
  - 26 G3 X-2.6844 Y-1.9674 I0. J0.
  - 27 G3 X-2.2514 Y-2.4509 I-.015 J-.0123
  - 28 G3 X-1.306 Y-1.4183 I-1.7787 J-1.9346
- Tool List:**
  - G03 G04 G38 G09 G17 G90 G71 G52 G40
  - G54 G501 G94 G97 G92 G24 G26
  - G73 G999 G10 G16 G51 G12 G80
  - M05 M00 M09 M48 M06 M61
  - M62:1 M07 M08 M19
- Navigation Panel (Right):** Includes buttons for Prod, Prog, Tool, Work, Variable, Diag, Service, and Mode.
- Function Keys (Bottom):** F1 Help, F2 Function, F3 OM/OP/R, F4 Delta/Lag, F6 Axes, F7 Blocks, F8 Axisinfo, F10 Spindle, F12 Mode.

# Flexium+ CNC System

## Flexium+ System Overview Components

### Flexium 3D

Providing fast and accurate 3D simulation, Flexium 3D is a graphical simulation software for part programs written in ISO-code (DIN 66025 with NUM extension) suited for different applications like milling, drilling and/or turning, as well as water jet and plasma cutting, etc. Other structures of machines can be created using the embedded machine editor.

It is available in two versions

- Office version: Flexium 3D can be used as a standalone program in production planning, without a CNC, to verify and optimize manually written or CAM generated part programs with direct source reference
- Machine version: here, Flexium 3D forms an additional part of the Flexium+ HMI and is connected to the CNC. Flexium 3D can be used either to pre-simulate part program (even during processing of another) or to provide synchronous online simulation during part processing

During part program simulation you can visualize the path of the TCP (tool center point), simulate material removal from the work piece, and check for collisions between machine components, part and tool.

It exists in different configurations for milling, turning, as well as waterjet and plasma cutting.

- Turning: 3-5 axes simulation of part programs. Includes simulation of grooving, thread cutting and tapping movements and cycles
- Milling/drilling: 3 axes simulation of part programs. Includes simulation of standard milling and drilling cycles (4 to 5 axes simultaneous processing with RTCP and inclined plane are planned)
- Cutting: 2D/3D visualization of cutting contour. The configurable moving zoom window of the tool center point environment is used to illustrate local contour when comparing huge work pieces

Main features of Flexium 3D simulation:

- Wired path simulation (standard)
- Workpiece and Machine view (standard)
- Material removal
- Collision detection
- Tool Editor (standard)
- Blank Editor (standard)
- Machine Editor (standard)

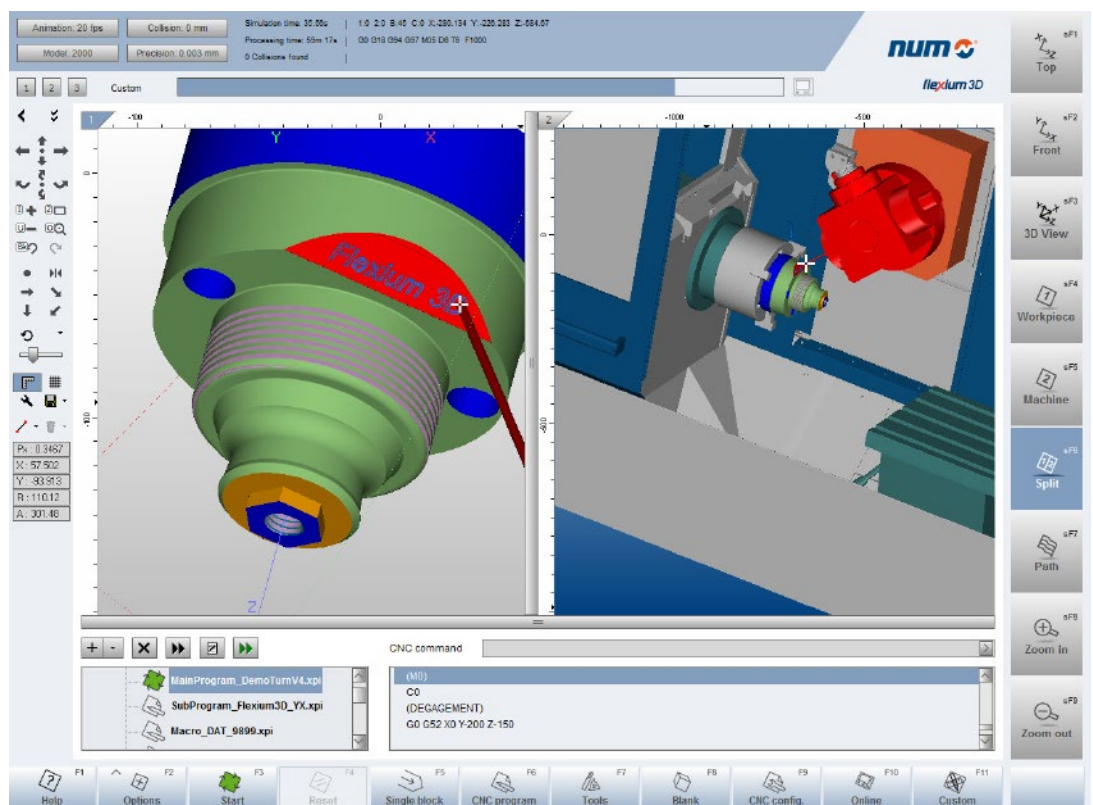

### Drives

The modern design of NUMDrive X servo drives makes them the ideal counterpart to the powerful Flexium+ CNC.

One distinguishing feature of the NUMDrive X is its high power density. The servo drives offer an enormous amount of computing and drive power within a very small space and thus have one of the highest power/volume ratios available. A high degree of integration and efficiency has allowed us to achieve an extremely compact design that makes NUMDrive X one of the smallest high-end drives on the market. Thanks to a small depth and a modular width (a multiple of 50 mm) the cabinet layout is greatly simplified.

The range is characterized by a wide choice of current from a few amperes up to 200 Arms, Bi-Axis versions are available up to 2x35 Arms to enable each application to be optimized at the lowest cost. For the maximum contour precision, speeds and cost-effectiveness, the NUMDrive X servo drives can be exactly adapted to the particular machine and application.

NUMDrive X is a modular system that is optimized for multi-axis applications. Use of a common power supply unit means that only one mains connection, one line filter and one braking resistor are required per system, reducing cabling and overall costs. The system's modularity also facilitates energy exchange between different axes via the DC bus, offers the possibility of using stored energy for retraction purposes, and – in the case of regenerative power supplies – allows energy to be re-injected into the mains to reduce machine operating cost. Such system conception also leads the way for a greener approach.

NUMDrive X offers a choice of two performance levels:

- Standard-Performance (SP) drives
- High-Performance (HP) drives

Featuring high internal resolution, a short sampling time and specially developed algorithms, the HP versions are designed for sophisticated and complex applications in precision machine tools. The position control loop is closed with a very high bandwidth, achieving exceptional precision and speed at the mechanical interface of the machine (motor axis, linear motor). NUMDrive X accepts almost all measuring systems and can control a broad range of motors (servo, torque, linear, asynchronous motors) from NUM or other manufacturers. This ensures that a solution can be optimized from the technical and economic perspectives.

The HP versions of NUMDrive X also incorporate unique functionality known as DEM-X (Drive Embedded Macro). This allows users to create their own real-time macro which can interact with all physical and virtual drive resources – even to the extent of manipulating the regulation algorithms. Users can design and implement filters and monitors, define test points and create pilot outputs that obey user-stipulated rules.

The SP versions of NUMDrive X are suited to systems and precision machine tools of medium complexity, as well as cost-sensitive applications.

Within the NUMSafe architecture, NUMDrive X provides the safe motion functionalities by means of two different modules:

- NUM-STOX is the basic module for implementing the Safe Torque Off function certified up to SIL 3 according to IEC 61508. This allows the realization of E-STOP functions category 0 and 1 according to EN60204-1
- NUM-SAMX is the extended functionality module which provides a huge number of safe motion monitoring functions. STO Safe Torque Off, SLS Safely Limited Speed, SOS Safe Operational Stop, SS1 Safe Stop 1, SS2 Safe Stop 2, SLP Safe Limited Position and SDM (Safe Direction Monitoring)

Every machine builder has experienced the complexity of encoder wiring and knows that it takes time and effort to install and debug satisfactorily. NUMDrive X introduces a revolutionary innovation to overcome these issues. The drive incorporates a full digital encoder interface which uses a two-wire communication protocol. The two wires are integrated in the power cable. For more detailed characteristics on such encoders please refer to the Motors chapter.

For controlling auxiliary axes or auxiliary spindles, the NUMDrive C with CANopen interface is the most suitable solution. The CAN interface complies with a subset of the Device Profile DS402. The EDS (Electronic Data Sheet) files are available for the application of Mono-Axis and Bi-Axis versions.

### Motors and Encoders

NUM produces a diverse range of brushless motors, all of which feature high power-to-weight ratios and superb dynamic performance, enabling solutions to be perfectly tailored to each application. In conjunction with NUMDrive X servo drives these motors offer high speed and power capabilities, as well as excellent stability even at very low rotational speeds. The motors are fitted with robust optical encoders of different resolution/accuracy levels to fit the requirements of the machine and the application.

As already indicated in the NUMDrive X section, the newest motor ranges SHX and SPX integrate a revolutionary encoder which on two wires only handles the encoder supply voltage, as well as high resolution position, redundant position (for safe applications), motor thermal sensor and diagnostic data. This solution eliminates the need for a separate encoder cable, so there is no longer any need to crimp and solder a large number of wires. The power cable merely contains two additional shielded wires, which are connected by screw terminals on the drive side. Aside from reduced installation time and cost, other advantages include reduced cabling costs, smaller cable carriers, lower moving masses, better reliability and electromagnetic immunity, and higher resolution control.



### PLC and I/Os The PLC

---

The PLC of the Flexium+ system is programmed in accordance with IEC 61131-3. Thanks to the five languages available in the programming suite, Flexium Tools, the most complex applications can be handled quickly and efficiently.

This development environment offers dedicated tools for development, commissioning and maintenance.

The complete machine project is defined graphically, using several wizards to help set up the drives, I/Os and CNC.

The PLC program editors can be opened in the following languages:

- Instruction List (IL)
- Ladder (LD)
- Function Block Diagram (FBD)
- Structured Text (ST)
- Sequential Function Chart (SFC)

**In order to protect their specific know-how, customers can create their own compiled libraries in addition to all standard libraries provided.** The functions included in such libraries will be considered as 'black-boxes'. They will perform the functions they are intended for but none except the creator will have access to the code inside.

A Flexium+ project contains all the data to run a machine (machine structure, components, parameters, programs) which helps restore the machine to an operational condition should anything go wrong.

**For enhanced security it is strongly recommended that an archive of the project is left with the machine. Different access rights can be assigned to the archive to prevent unauthorized use or tampering of its content.**

---

### PLC in a Multi-NCK System

---

A multi-NCK Flexium+ system for large machining cells can consist of up to 16 NCKs connected to a single PLC. This concept ensures the highest performance and makes configuration as well as operation simple and reliable.

# Flexium+ CNC System

## Flexium+ System Overview Components

### Flexium+ I/Os

The Flexium+ I/O system is based on EtherCAT (Ethernet for Control Automation Technology). This real-time Ethernet technology is standardized by the EtherCAT Technology Group. In addition to its large acceptance and fast speed, EtherCAT opens the way to the Safe architecture NUMSafe thanks to the FSoE<sup>1</sup> protocol.

### EtherCAT Protocol Process

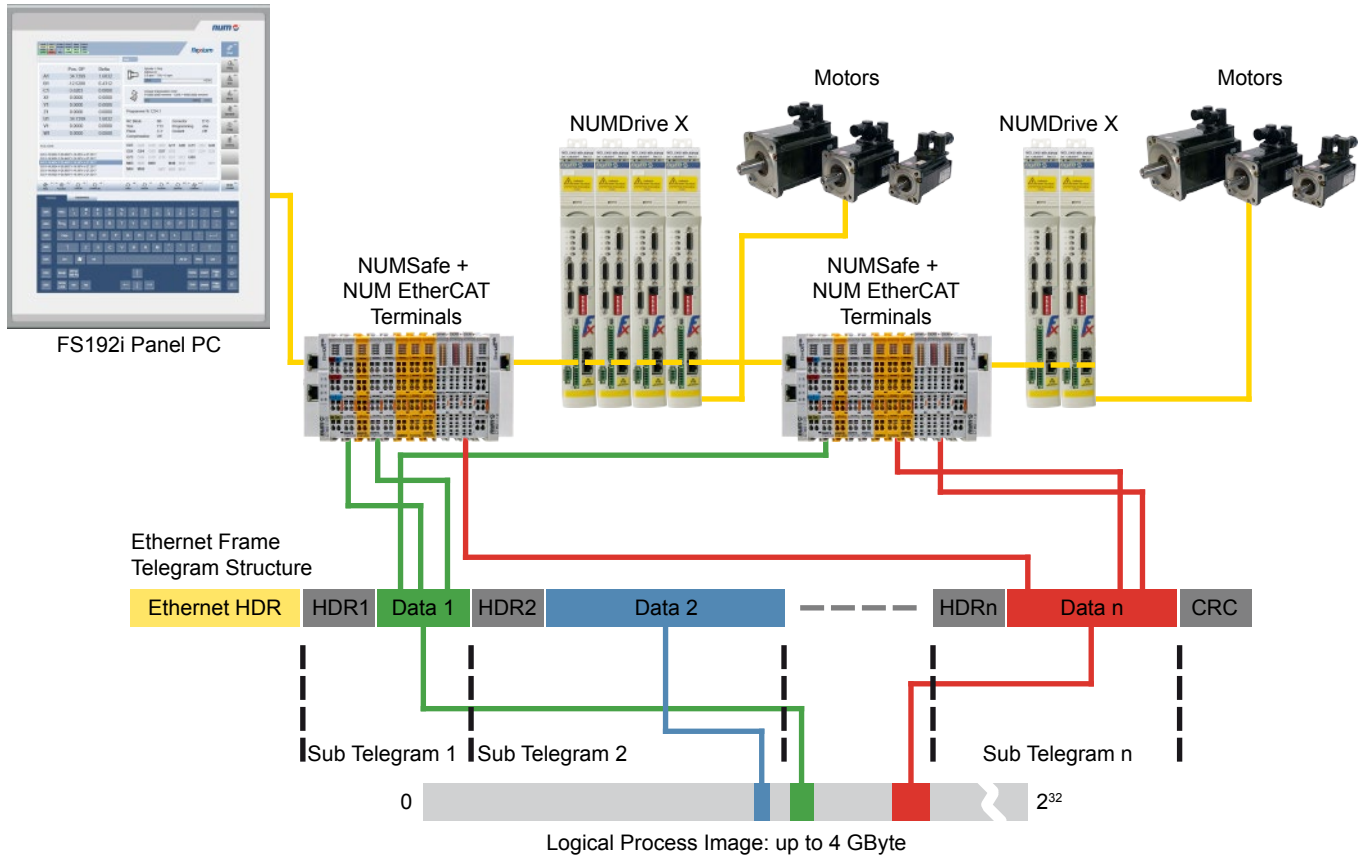

2

<sup>1</sup> FSoE: Fail Safe over Ethernet

### Flexium+ I/Os

#### Connection Topology - EtherCAT Fieldbus Combination

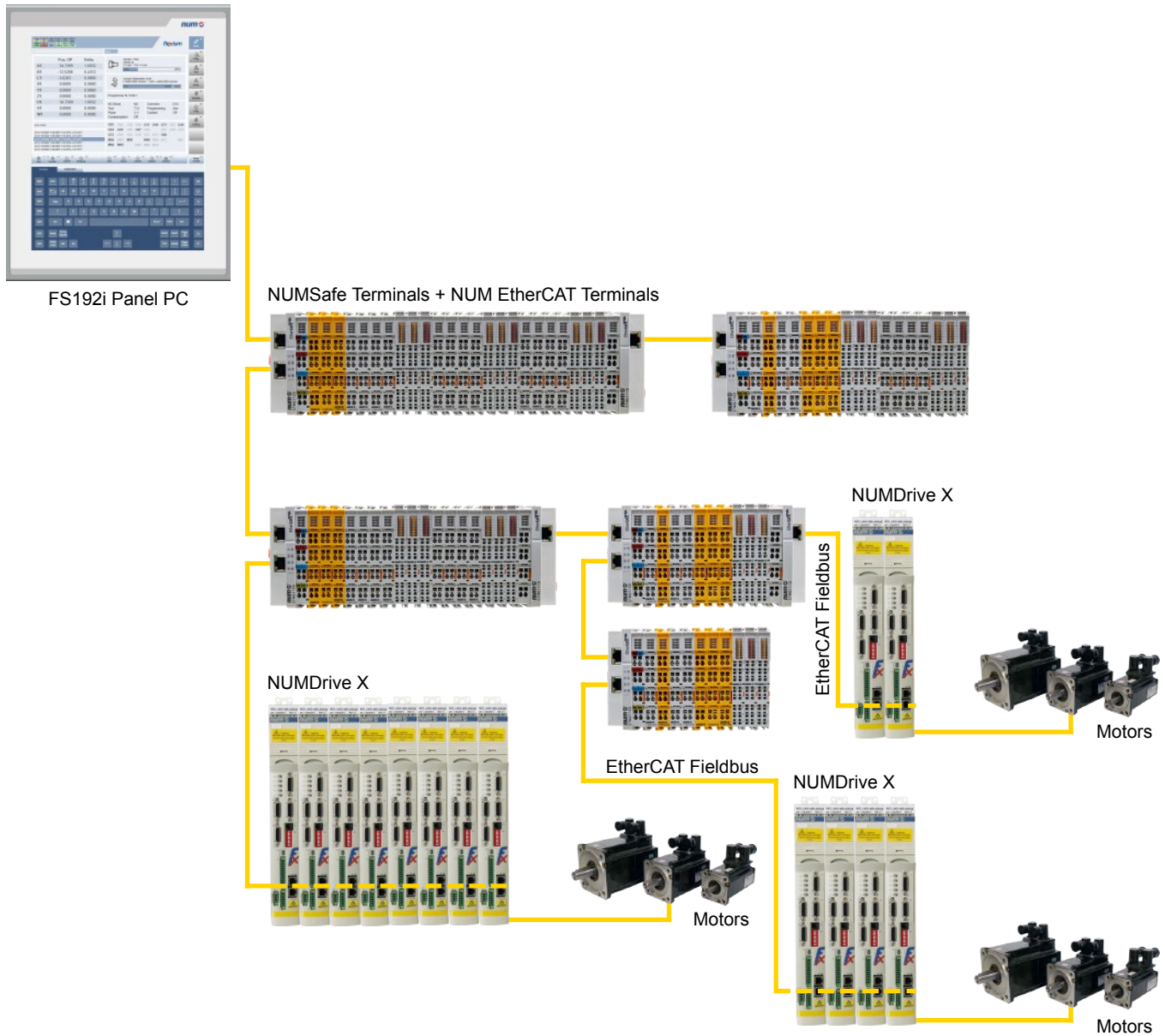

The range of I/Os consists of:

- Gateway module CTMG1100 / Gateway extension CTMG1110
- Digital and analog I/O module CTMTxxxx
- Technology modules CTMTxxxx

### Flexium Tools

This package running under Windows XP to Windows 8 includes all functions needed for the integration and commissioning of machines. Under a unique environment, it allows users to declare, parameterize and adjust all system components.

- Flexium+ NCKs (CNC)
- PLC structure (I/Os) and program
- Servo drives and motors
- Sensors
- EtherCAT and CANOpen gateways with a comprehensive set of I/Os and logic terminals

#### Easy Operation

The menu structure of Flexium Tools provides a perfect overview of the entire system. The different devices are displayed under a tree structure allowing easy access to all functions for online visualization and settings.

#### Project Handling

Access rights can be defined for different users. Each project consists of one single file to ensure easy handling and to prevent data losses. New equipment or versions are quickly integrated using Electronic Data Sheets (EDS) for I/O devices and Device Descriptions (DevDesc) for NUM devices. Libraries can be used in different versions and can be compiled to protect know-how. Complete projects, including libraries, devices and the source code can be archived, thus making restoration possible at any time in the future.

#### PLC System Programming

The PLC of the Flexium+ system is programmed in accordance with IEC 61131-3 and supports different graphical programming environments.

The logical and easily manageable development environment offers dedicated tools for development, commissioning and maintenance. The PLC program structure is displayed in a logical structure showing the different blocks and folders. The program editors can be opened in the following languages:

- Instruction List (IL)
- Ladder (LD)
- Function Block Diagram (FBD)
- Structured Text (ST)
- Sequential Function Control (SFC)

The PLC provides libraries for system functions, customer functions and its own programming functions.

Task management is very flexible with tasks that can be cyclic, event-controlled or freewheeling.

Data and variables are based on of a high level language. Data types can also be user defined.

The program can be easily structured using program building blocks, functions and function blocks with entities.

Object oriented programming is also supported and allows safe programs using objects, methods, properties, actions, interfaces and inherit functions.

# Flexium+ CNC System

## Flexium+ System Overview Components

### Flexium+ NCK (CNC) Parameterizing

Dedicated editors for options, programming, memory, channels, axes (with individual windows for settings, coupling, kinematics, travels, servo system, HSC) miscellaneous hand wheels, axes calibration and more ensure easy handling and the best overview during editing.

### Servo Drives Parameterizing

All servo drives of the Flexium+ System can be found and accessed easily in the menu structure of Flexium Tools. For better overview, the device structure is displayed in the way the system is set up, e.g. servo drives are listed under the controlling Flexium+ NCK.

### Field Busses

Theoretically, any CANopen and/or EtherCAT compatible device can be connected to the bus using the EDS/ESI/XML file supplied with the device. NUM provides a comprehensive range of most common I/O components based on EtherCAT (Ethernet for Control Automation Technology). This real-time Ethernet technology is standardized by the EtherCAT Technology Group.

NUM also provides machine panels (like MP04), drives for auxiliary axes and other devices that, by means of dedicated windows and libraries, can be easily integrated as field bus devices (CANopen).

### Instruments

For easy commissioning, a huge set of instruments is available: Frequency Analyzer, Ball-Bar, Contour Accuracy Oscilloscope and others.

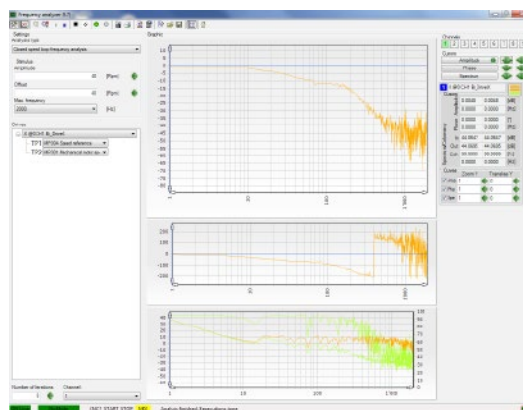

### Ball-Bar Function

The ball-bar function is integrated in Flexium Tools. It checks the behavior of the axes and allows adjustment of the servo drives' parameters.

Thanks to circles drawn by G02/G03 or by small segments (Tabcyls), this function generates a diagram of the radial error on the main axes or other axis pairs, which facilitates adjustment of the following parameters:

- Acceleration anticipation coefficient
- CNC reference filter time constant
- Pitch compensation.

Example of a Ball-Bar trace:

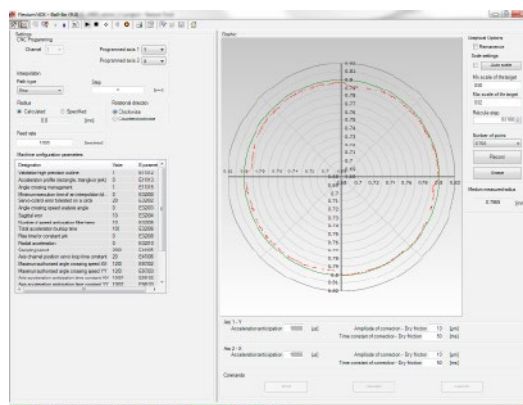

### Flexium+ and Safety

The NUMSafe function, perfectly integrated with the regular I/Os, implements safety technology in the Flexium+ system. Offering a wide range of benefits in terms of scalability, flexibility and reduced wiring needs, NUMSafe also provides a common programming environment for all system devices.

Architectures with mixed standard and safety related signals and components are possible.

The NUMSafe offer consists of:

- NUMSafe PLC (CTMP6900),
- NUMSafe Digital Input modules (CTMS1904) and
- NUMSafe Digital Output modules (CTMS2904)

Such components are positioned together with standard I/Os. By means of a NUM EtherCAT gateway they communicate with the automation PLC, with other EtherCAT gateways, servodrives and safety related components. The safety related motion functions are realized inside NUMDrive X by means of the NUM-SAMX board.

All safety related information is transmitted over the standard EtherCAT connection, with data reliability ensured by use of a Fail Safe over EtherCAT protocol (FSoE); wiring is reduced to a minimum, while flexibility and scalability are maximized.

The available monitoring functions, according to EN 61800-5-2, are:

- Safe Torque Off (STO)
- Safe Operating Stop (SOS)
- Safe Stop 1 (SS1)
- Safe Stop 2 (SS2)
- Safely-Limited Speed (SLS)
- Safely-Limited Position (SLP)
- Safe Direction Monitoring (SDM)

NUMSafe is compliant with EN 13849-1 and EN61800-5-2 up to PL e and SIL 3 respectively.



### Type of Platforms

---

<b>FXP1101100</b>	<b>Flexium+ 6</b>
<b>FXP1101150</b>	<b>Flexium+ 8</b>
<b>FXP2101200</b>	<b>Flexium+ 68</b>

The characteristics and content of each platform are described in Basic Features and Optional Extensions, page 58.

---

### Configuration

---

<b>FXSO200060</b>	<b>Turning</b>
<b>FXSO200061</b>	<b>Milling</b>

Each Flexium+ system can be configured for milling or turning. The choice is free of charge but must be stipulated at the time of order.

The main consequences of this choice are the canned cycles and the pre-selection of the interpolation plane.

The two options can be combined for more complex machines under the reference FXSO000581 (later in this chapter).

---

### Multi-NCK

---

<b>FXSW282117</b>	<b>System Multi-NCK</b>
-------------------	-------------------------

The Flexium+ 68 controls up to 32 axes/spindles in up to 8 channels. Multi-NCK extends this limit and allows control over several Flexium+ NCKs connected to one single PLC. Such systems can include more than 200 axes and are typical for NUMtransfer solutions.

For the operator, the several NCKs present themselves as just one machine, making operation clear and simple.

In large systems several operating panels can be used (multi-panel configuration).

---

### Axes, Spindles or Measure Inputs

---

<b>FXSO100006</b>	<b>6th axis/spindle</b>
<b>FXSO100008</b>	<b>7th and 8th axes/spindles</b>
<b>FXSO100012</b>	<b>9th to 12th axes/spindles</b>
<b>FXSO100016</b>	<b>13th to 16th axes/spindles</b>
<b>FXSO100032</b>	<b>17th to 32th axes/spindles</b>
<b>FXSO100373</b>	<b>Analog interface 1 for axis or spindle</b>
<b>FXSO100374</b>	<b>Analog interface 2 for axis or spindle</b>

These axes are directly controlled by the CNC software using a program loaded into the user memory area, or in drip feed mode for large programs (for example a CAD/CAM). Movements are generated in an X, Y, Z Cartesian coordinate system which may be supplemented by additional U, V, W axes. These axes may be independent or grouped in carrier/carried axis pairs. Three rotary axes modulo 360 degrees, A, B and C, are associated with the main linear axes.

### Handwheels

---

<b>FXSO100375</b>	<b>Handwheel interface 1</b>
<b>FXSO100376</b>	<b>Handwheel interface 2</b>
<b>FXSO100377</b>	<b>Handwheel interface 3</b>
<b>FXSO100378</b>	<b>Handwheel interface 4</b>

A Flexium+ system can handle up to four handwheels per NCK. Handwheels are interfaced on CAN or on the analog ports of the NCK (no more than 2 in this case).

Handwheels can be used for manual control of axes with a possibility of three values of increments. Validated by a specific G code, they can also be used to accelerate a move (gap-elimination) or to introduce a differential shift between axes.

Several types of handwheel devices are available in our offer: standalone, integrated in a machine panel or portable (please refer to chapter 3).

### Interpolation Capability

---

<b>FXSO100335</b>	<b>5th interpolated axis</b>
<b>FXSO100336</b>	<b>6th interpolated axis</b>
<b>FXSO100337</b>	<b>7th interpolated axis</b>
<b>FXSO100338</b>	<b>8th interpolated axis</b>
<b>FXSO100339</b>	<b>9th interpolated axis</b>

According to the selected option, the system is able to move the defined number of axes in complete synchronization. The feedrate applied is defined on the linear axes; additional axes will synchronize themselves to this feedrate. As a complementary feature it is possible to define with which axes the feedrate should be computed (function G92 F...).

### Multi-Channels

---

<b>FXSO100392</b>	<b>2nd channel</b>
<b>FXSO100394</b>	<b>3rd + 4th channel</b>
<b>FXSO100396</b>	<b>5th + 6th channel</b>
<b>FXSO100398</b>	<b>7th + 8th channel</b>

In the basic version, the Flexium+ 6 controls a single channel. Flexium+ 8 can control two channels and Flexium+ 68 up to 8 channels per NCK.

During commissioning, the CNC axes and spindles of a machine are dispatched among all channels available by machine parameter. Part programs can later modify this configuration if authorized to.

In a multi-channel system, the machining program consists of independent programs (one per channel) denoted by a common program number, followed by the channel number.

A spindle declared in a channel can be controlled by that channel or be released and controlled independently.

A multi-channel system can be configured in two ways:

- **Common Mode:** all channels simultaneously in the same mode. START, STOP and RESET commands are unique
- **Independent Mode:** when in execution, the different channels can execute different part programs in different modes (homing is always in common mode), the START, STOP and RESET commands are independent for each channel

The first channel is always an NC channel; additional channels can be configured as:

- **NC Channels:** with all functions of the first channel
- **Auxiliary Channels:** these execute a particular part program %9998.i under control of the PLC. This is very useful for machine functionalities like tool changer, pallet changer etc...



### Axis Generalities

---

Chapter 2 defines the axis configurations according to the system selected.

Axis and spindle performance is described below:

- Internal system resolution is  $10^{-9}$  meter with a maximum travel of  $10^3$  meters for linear axes and  $10^{-6}$  degrees with a maximum of  $10^6$  degrees for rotary axes (unlimited in case of modulo axis)
- The programming resolution is freely fixed from the nanometer to the 1/10 of mm for linear axes and  $10^{-6}$  degrees to  $10^{-1}$  degrees for rotary axes
- The maximum feedrate is linked to the sampling period and could go up to 1800 m/mm for linear axes and 5000 rpm for rotary axes
- The spindle speed ranges from 0.01 rpm to more than 100000 rpm

### Axes and Spindles Features

---

#### Digital Axes Bus

DISC NT+ servobus is based on a high-speed digital bus which manages transfers between the CNC axes and spindle servo drives.

This distributed architecture ensures very fast positioning and excellent servo system stiffness, thereby optimizing contour-following and surface finish.

In addition, such architecture saves an enormous amount of time on wiring and installation.

### Memory Functions

---

As standard, Flexium+ systems provide more than 40MB of dynamic memory for part programs. The permanent connection to the panel provides access to mass memory (hard drive or SSD) and optionally the LAN, offering almost unlimited storage capacity. From mass memory, the program can be stored in the dynamic memory for execution or it can be executed in drip feed mode (certain restrictions may apply).

The memory structure is as below:

This part of the global memory can be divided into four functional areas:

- Area 0: Modifiable user area (NC memory)
- Area 1: Protected customer area
- Area 2: Protected OEM area
- Area 3: Area reserved for NUM

Each program or macro in the protected areas can be protected against display, editing and downloading. This safeguards proprietary information and guarantees the functional integrity of the machine.

#### Resident Macros

Resident macros are part programs developed by NUM, the OEM or the customer himself, and are loaded into the protected memory areas. These programs are written in standard ISO language and structured programming to facilitate understanding and modification (examples: customized canned cycles).

**Editing the Macros Related to Canned Cycles:** A utility included in the Flexium+ HMI is used to retrieve these cycles for editing purposes. The modified cycles can then be retransferred to any area (other than the NUM area), where they will get a higher priority.

#### Program Editing

Programs can be edited in the mass memory (hard disk) area at any time. Such modifications will be taken into account only after reloading the program in the NC.

It is also possible to edit the programs directly into NC memory in end of block stop. Such edits are taken into account immediately. This is very useful for example to change a feedrate or to correct a syntax error.



## Axis Functions

### Standard Axis Functions

---

#### **Axis Calibration**

This function corrects the axis position according to the defects of the screw, rack or scale.

#### **Interaxes Calibration**

This function corrects the position reference of an axis via the position of another axis. The data are entered in a table. A typical use of this function is to compensate for the weight of the “ram head” on a milling machine.

#### **Backlash Compensation**

Positioning errors due to mechanical backlash on the linear and rotary axes are corrected automatically. The correction is related to the direction of movement.

#### **Dynamic Limit Switches**

The machine travels entered when setting up the machine may be dynamically limited by software. Dynamic limit switches are active in all modes.

#### **Look-Ahead Function**

The «Look-Ahead» function enables the NC to make a predictive analysis of the programmed path across several single machining blocks in advance. Thus, it has the opportunity to recognize the path characteristics and react accordingly. For optimal functioning of Look-Ahead, Flexium+ CNC prepares up to 1000 blocks per NC channel to adapt the programmed feed-rate even when there are many very small NC segments.

#### **Acceleration and Deceleration Control**

Allows progressive as well as Jerk-controlled acceleration functions to be used for smoother mechanical operation on high-speed machines.

#### **Anti-Pitch Correction**

When movement on an axis is reversed, this compensation prevents spikes at quadrant changes.

#### **Table Eccentricity Compensation (DAT3)**

This function applies to the A, B or C rotary axes. Shifting the main axes compensates the offsets due to the non coaxiality between Part Origin and the axis of rotation of the table. This eccentricity can be entered:

- On the CNC panel
- By external parameter E
- By extended NCK exchange

Please note that the compensation is not continuous. It is only taken into account when the main axes are moving. A continuous correction requires a dedicated application.

### Optional Axis Functions

#### FXSO000266

##### Duplicated and synchronized axes

This function couples one or more slave axes with a master axis, either by setting machine parameters (fixed coupling) or by programming external parameters. It also ensures synchronization of the master axis with the slave axis (it does not include axis control).

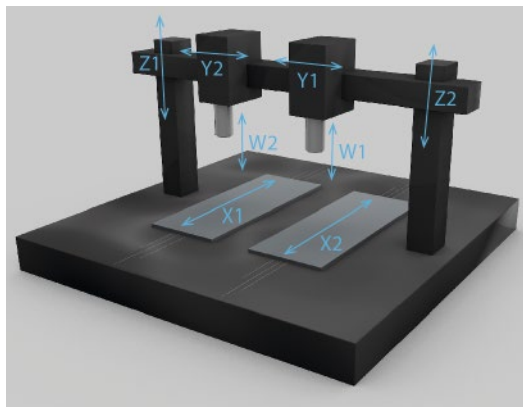

The figure above shows a mechanical gantry axis pair (Z1 and Z2) and programmable gantry axis pair (X1 and X2, Y1 and Y2).

#### FXSO000315

##### Inclined or tilt axes

On a lathe or a grinding machine, the X and Z axes can be orthogonal or inclined. The axis inclination or tilt is the angle A between the X axis and the normal to the Z axis. Coordinate conversion takes place downstream of the interpolator. In a multichannel system, different axis inclinations can be specified for each channel.

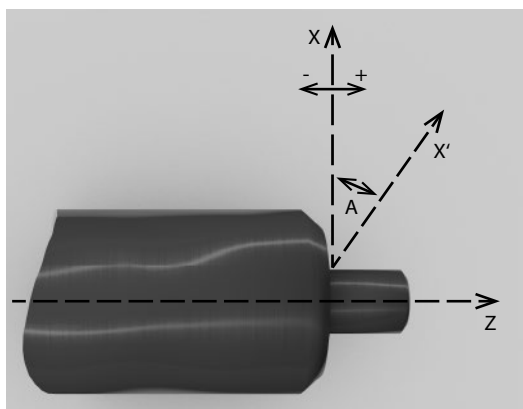

A: angle of inclination

#### FXSO000340

##### Conversion Cartesian to polar/cylindrical

In this turning configuration, the spindle is used as an interpolated axis with one of the CNC axes (X or Z). A resolution of at least 90,000 points per revolution is required for the measurement sensor. The spindle motor sensor used for the speed loop must be a high resolution sensor.

#### G20: Programming in X, Z and C polar coordinates

This function is used to program the X and Z linear axes and control a rotary C axis modulo 360 degrees.

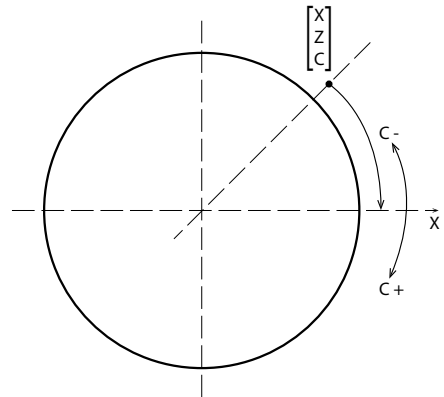

Use of G20 and polar coordinates

#### G21: Programming in X, Y and Z Cartesian coordinates

The system performs Cartesian/polar coordinate conversion (conversion of X-Y to X-C). The X and C axes are interpolated for milling in the plane perpendicular to the spindle axis. The tool is driven by an auxiliary spindle.

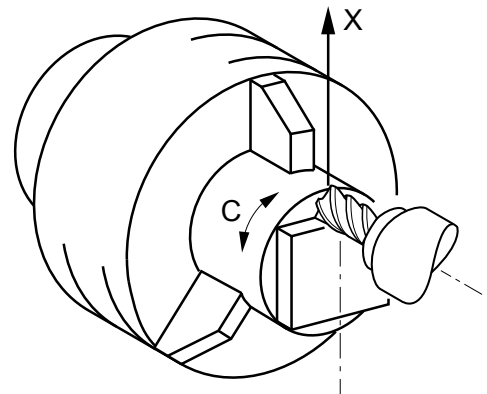

Use of G21

#### G22: Programming in X, Y and Z cylindrical coordinates

The system performs cylindrical/polar coordinate conversion (conversion of X-Y to Z-C). The C axis is interpolated for milling on the involute of the cylinder with radius X. The tool is driven by an auxiliary spindle.

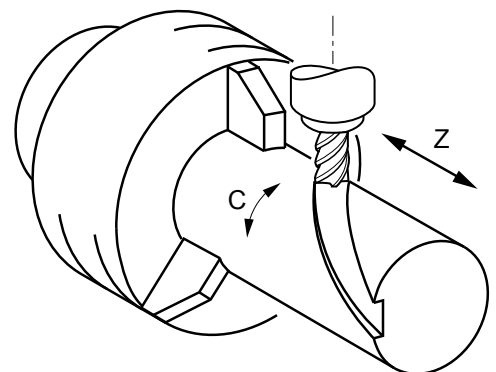

Use of G22

### **FXSO000426** **NURBS (B-Spline) interpolation**

Geometric continuity of contours is a necessity for High Speed Cutting (HSC). NURBS (Non Uniform Rational B-Spline) curves, widely used in CAD and now on CNCs, are curves with poles that describe a contour in rational parametric form in order to be able to cut complex shapes with a minimum of contour error.

### **FXSO100453** **Tandem function**

This function includes two algorithms that are very useful for interdependent motors:

- Backlash compensation
- Torque synchronization

### **FXSO000497** **Circular interpolation by three points**

This function (G23) is executed by programming:

- The start point (defined in the block preceding function G23)
- The end point and the intermediate point (defined in the block including function G23)

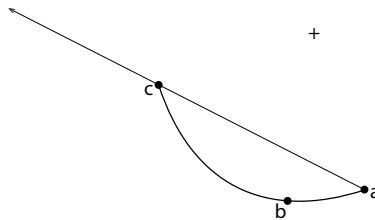

### **FXSO000499** **Smooth polynomial interpolation**

Smooth polynomial interpolation allows creation of tool center paths defined by polynomials of 5 degrees or less. These paths are perfectly smooth continuous curves without segments. All the calculated points are located strictly on the curve.

This type of interpolation cannot be used on modulo axes. It is incompatible with tool offsets and backtrack along the path.

### **FXSO000514** **Radial axis boring/milling function (U-axis)**

This function allows interpolation of a radial axis (Z or U) as required for a boring application.

### **FXSO000518** **Spline-Interpolation (G06, G48, G49)**

Spline interpolation is a mathematical method for smoothing curves. Spline curves are apparently continuous curves obtained by linking a series of points.

With spline interpolation, the tangent is continuous and the acceleration is constant in each of the points specified on the programmed paths.

Machining of a spline curve is programmed by defining:

- The points on the curve
- The sequence of execution of the curve

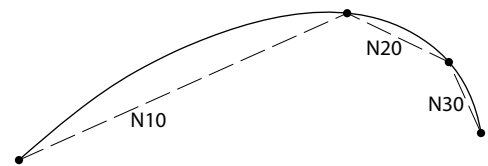

### **FXSO181706** **Spline interpolation with curve smoothing**

Based on polynomial interpolation, this function allows the programmer to define curves of any shape in three dimensions, merely by defining the intermediate points.



## Optional Spindle Functions

---

### **FXSO000156**

#### **Spindle synchronization**

This function controls speed synchronization of two measured spindles. It is used in particular for machining operations such as parting off.

Synchronization can be obtained with stopped spindles but also on the fly while the master spindle is rotating. The system will take into account the acceleration capacity of the slave spindle.

### **FXSO000331**

#### **Axis/spindle synchronization**

This function slaves the tool displacement to spindle rotation. It is used in particular for thread chasing.

This function also includes constant pitch thread-cutting cycles.

### **FXSO000332**

#### **Rigid Tapping**

The infeed on the tool axis is synchronized to the spindle rotation. At the end of tapping, reversal is gradual and smooth.

This function avoids the need of an axial floating tool holder.

### Machining Functions

#### **FXSO000154** **RTCP (Rotation Tool Center Point)**

The RTCP function (Rotation around Tool Center Point) can be used with all known five-axis machine structures.

It provides automatic compensation on the main machining axis for the offsets caused by movement of the rotary axes of a five-axis machine. This compensation preserves the position of the center of a ball-end tool during interpolation.

The RTCP function is parameterized using Flexium tools. The installation program generates a macro containing a description of the machine's kinematics.

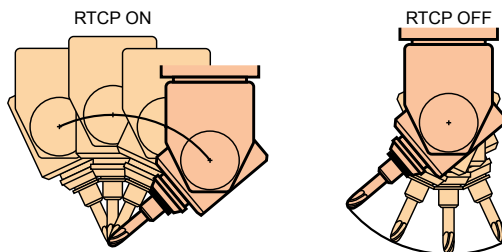

#### **FXSO000155** **High speed cutting**

This function practically eliminates the following error, even at high machining speeds. This is achieved by the following mechanisms:

- Total speed anticipation
- Acceleration anticipation
- Anti-pitch correction: when machining circles, the friction torque appears as dynamic backlash when reversing direction; the adjustable correction compensates for this friction torque
- Gradual acceleration with controlled jerk-rate derivative
- Accurate feed control based on upcoming changes in the machining path

This control requires evaluating the curve radius over a sufficiently long section of future path (horizon). It also requires detecting and evaluating the sharpness of corners which may exist on this segment of path. For form machining, up to 1000 blocks per channel can be pre-analyzed.

#### **Preliminary: NUMcoss**

NUMcoss is an additional component of High Speed Cutting (HSC) functionality in NUM CNCs (Flexium). It is integrated into Flexium+ HMI Panel software.

#### **Technical Principle and Targets**

With NUMcoss, the customer will get an excellent tool to speed up program execution for milling applications. Prior to data transfer to NC-kernel, NUMcoss analyses, smoothes and converts path conditions of the CAM generated ISO-programs into polynomial data. As this conversion happens on Flexium+ HMI (PC-side) the NC-kernel is not involved and its performance is free for quick interpolation and the ramp algorithm.

The main criteria in the geometric transformation of NUMcoss are modification tolerance and chord error for linear and rotary axes. That means in which dimension the given linear data (polygon path) can be modified during transition to polynomial data. Additional criteria are specific treatment of different segment lengths as well as correct filtration of spikes and geometric gaps.

#### **Smoothing Configuration**

NUMcoss provides a standard set of smoothing configuration parameters for the machine or application. These parameters can be changed in the ISO-program with specific commands. In addition to this, users can define their own sets of smoothing parameters depending on the type of machining (rough, finish and fine finish).

NUMcoss is an optional functionality for high speed applications. It can be used for analyzing and smoothing ISO-files either in drip feed mode (PPP) or for any other standard ISO-file execution.

#### **User Benefits**

With NUMcoss user benefits are:

- Improved part quality (enhanced performance, less machine noise, reduced number of facets on the work piece)
- Higher execution velocity (less-data transfer, fast polynomial interpolation, and guaranteed smoother axis movements)
- Higher accuracy (pre-defined error given from CAM data generation) will be achieved

### FXSO000404

#### Tilted nozzle management

This feature is mostly used for jet cutting applications. It is intended to take into account the fact that the cutting head is not always perpendicular to the interpolation plane by recalculating the angles and continuously repositioning the nozzle to keep the same inclination.

The nozzle orientation vector, that will finely reposition the head, is defined by two curves figuring the jet center path at the top of the part and at the bottom of it.

- At the top, the trajectory is created from the program trajectory like for the usual G41/G42 compensation
- At the bottom the trajectory is offset by the value of the jet radius + the tilting effect (nozzle angle along the part height)

Depending on the type of crossing it may add an additional connecting block between two programmed blocks. It also performs the anti-collision monitoring at top and at bottom.

Due to the orientation the jet section is no more a circle but an ellipse. The system will automatically adjust the value to compensate correctly.

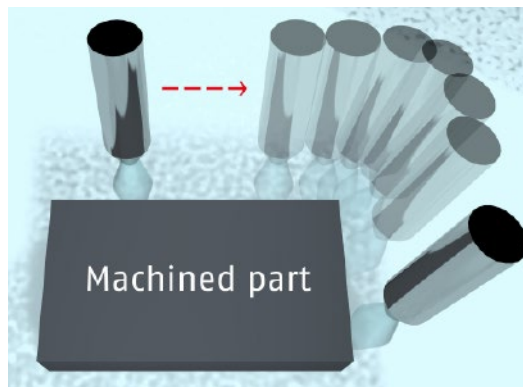

### FXSO000581

#### Combined machine (turning + milling)

This option includes the basic milling functions plus several functions for controlling a combined machine (milling + turning):

- Axis/spindle synchronization
- Support of a radial axis (drilling)
- Cartesian/polar coordinate conversion
- Turning cycles

### FXSO000595

#### Automatic gear-alignment

This function is part of the NUMgear application and is intended to align a previously cut gear after it has been removed from the machine in order to execute an additional pass.

### FXSO000695

#### Milling and standard pockets cycles

##### Milling Cycles (G31, G81 to G89)

The milling cycles can be called from the main machining program:

- Drilling (center drilling, counter boring, peck drilling, drilling with chip breaking), tapping
- Various types of drilling
- Other cycles: thread chasing, etc

These cycles are provided by ISO subroutines (macros) that can be edited. The standard set can be customized for the type of machine and job for which they are used.

It is also possible to create special cycles. These cycles can then be called from the main program by G functions.

##### Rectangular and Oblong Pocket Cycles (G45)

These cycles facilitate execution of circular, oblong, rectangular and square pocket cycles.

##### N.B.: Customized Cycles

It is possible to create additional cycles that are specific to an application or a machine. These cycles are then called by new G or M functions. For G functions, it is possible to create programs %10100 to %10255 and call them by functions G100 to G255 respectively.

For unassigned M functions, a machine parameter, 'subroutine call by M function' is used to call a program number defined at installation when the M function is detected in the part program.

### FXSO000696

#### Turning cycles

##### Turning Cycles (G63 to G66, G81 to G87, G89)

These cycles can be called from the main machining program:

- Groove roughing, face-turn roughing, plunging
- Drilling (center drilling, counter boring, peck drilling, drilling with chip breaking), tapping
- Drilling cycles

These cycles can be edited and special cycles can be created. They are called by G functions (see Customized Cycles above).



### **FXSO000914** **Inclined plane machining**

The inclined-plane machining function manages many different machine head structures and simplifies programming of the machining operations.

Rotation and translation are combined to define a three-axis reference system with any orientation, used by the CNC to control the machine.

All the standard functions can still be used in this condition:

- L and R tool offsets,
- Canned cycles as well as control of speed and feed,
- Acceleration and travel

The inclined reference system is defined as follows:

- UVW / XYZ translations
- ABC rotations around each of the XYZ axes

All five-axis machine structures are supported with their offsets:

- Machine-head with two rotary axes with or without angle
- Machine-head with one rotary axis and turntable with one rotary axis
- Turntable with two rotary axes

The inclined plane machining function is parameterized using Flexium tools. The installation program generates a macro containing a description of the machine's kinematics.

### **FXSO100538** **Polygon-cutting cycles**

This turning function is used for cutting flats or polygonal shapes on the surfaces of parts of revolution.

The cutting technique is based on synchronization of a rotary axis with a spindle rotating in the same direction with a programmed speed ratio.

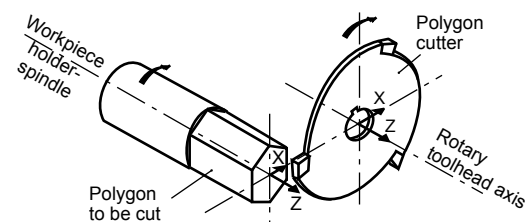

### **FXSO100590** **Probing cycles for turning**

These cycles are designed for use in adjustment and measurement applications generated manually or automatically.

They include the following functions:

- Probe calibration
- Tool presetting
- Workpiece measurement and offset adjustment
- Determination and restoring of DAT2 on the linear X and Z axes

All these cycles can be edited.

### **FXSO100591** **Probing cycles for milling**

These cycles are designed for use in setting and measurement applications generated manually or automatically.

They include the following functions:

- Probe calibration
- Tool presetting (L, R)
- Determination and restoring of DAT2 on the X, Y and Z axes (workpiece location)
- DAT2 on the A, B and C rotary axes (workpiece alignment on a table)
- Determination and restoring of DAT3 (off-centering of a workpiece on a table)

All these cycles can be edited.



## Programming Functions Standard Programming Functions

---

### ISO Code:

Flexium+ complies with the ISO standard and includes specific extensions for advanced functions.

The general programming format is as below:

%.....	
N.....	Sequence number
G...	Preparatory functions
XYZ+8.8	Axis movements
UVW+8.8	Auxiliary axis movements
ABC+5.8	Rotary axis movements
IJK+5.8	Circle center coordinates
EA3.3	Taper angle
EB5.8	Fillet or chamfer
EC3.8	Indexed spindle axis
ED3.8	Programmed angular offset
R8.8	Circle radius
F...	Feed rate
M...	Miscellaneous functions
S.....	Spindle speed
T.....	Tool number
D...	Tool offset
L...	Program variable
E.....	External parameter
H...	Subroutine number
/	Block skip

### Datum Shifts

Regardless of the programming mode selected, the system always processes the dimensions with respect to a zero point or origin.

#### Measurement Origin (OM)

The measurement origin is a suitable point defined on each axis which sets the absolute measurement origin or zero point. The coordinates of this point can be entered or modified in special machine parameters.

#### Part Origin (Op)

The part or workpiece origin is independent of the measurement system. It is defined with respect to a suitable setting point on the workpiece. The part origin is specified with respect to the measurement origin by datum shift DAT1.

#### Program Origin (OP)

The program origin defines the origin of the program coordinate system. It is independent of the measurement system and is specified with respect to the part origin by datum shift DAT2.

Flexium+ provides 4 Part origins and up to 99 program origins selectable by G code.

### Subroutines

Subroutines are special programs called by the main program. They are created by the OEM, by NUM (in the case of macros) or by the user to simplify and optimize the main program.

Example: Pattern repetition in several locations.

Subroutines can be called by the specific function G77. They can also be called by the PLC or by an M function.

### Parametric Programming

Parametric programming simplifies the writing of programs and the creation of identical families.

There are two kinds of parameters: L variables (Float) and E parameters.

L variables and external E parameters can be assigned to all the program addresses. Operations available on parameters:

- Addition, subtraction, multiplication, division, square root, truncation, sine, cosine, arc tangent
- Conditional and unconditional branches (>, <, =), logic
- AND and OR

### Profile Geometric Programming

This special ISO programming language allows the rapid development of parts with a complex geometry consisting of a sequence of linear and circular geometric elements.

Main Functions:

- Insertion of fillets and chamfers
- Multiple line definitions
- Multiple circle definitions
- Ability to implicitly declare from one to three consecutive elements and have the system compute the intersection or tangent points

### Customized Cycles

It is possible to create additional cycles that are specific to an application or a machine. These cycles are then called by new G or M functions. For G functions, it is possible to create programs %10100 to 10255 and call them by functions G100 to G255 respectively. For unassigned M functions, a machine parameter, 'subroutine call by M function' is used to call a program number defined at installation when the M function is detected in the part program.

### Inch/Metric

Internally, the system works in metric units. Display and programming default units for dimensions can be selected by a machine parameter when integrating the system. This default can be overwritten by the HMI, using function G70 for programming in inches, and function G71 for programming in metric units.



## Optional Programming Functions

---

### **FXSO000249      Dynamic operators in C**

Uses an identical principle to the standard dynamic operators (see item below).

The option of using C language brings additional power and the opportunity to access much more data.

The C compiler is not included. It will be indicated on request.

### **FXSO000250      Dynamic operators**

This powerful language opens the real-time kernel of the CNC.

It uses simple operations to perform real-time computations which can act directly on the axis position references and on discrete or analog inputs and outputs.

This tool, which also supports exchanges with the PLC program, offers the possibility of immediate correction according to the environment.

The dynamic operators operate with high priority at the real-time clock frequency of the CNC and do not penalize the functions managed by the CNC software. They are very useful in application programs, especially for operations on the servo systems and other high-speed tasks.

### **FXSO000506      Scaling factor (G74)**

The scaling factor can be entered from the keyboard or via an E parameter to modify the dimensions of the part to be machined. It is expressed in thousandths of the programmed dimensions.

The variations are between 0.001 and 9.999.

### **FXSO000507      Angular program offset (ED)**

Function ED is assigned a value which defines an angular rotation with respect to the program origin.

The angular offset affects the axes programmed in the blocks following the function.

Example of application: machining along a circular pattern.

### **FXSO000511      Recording current parameters values**

This function is used to save the values of several parameters in a file included in a subroutine or a block sequence of the main program.

The nominated file lists the L variables and E parameters that will be updated with current settings.

Syntax:

- G76 Transfers the current settings of L variables and E parameters to the specified program
- H Specifies the program to which the settings are to be transferred
- N..N.. Specifies the block sequence to which the settings are to be transferred

### **FXSO000520      On the fly measurement/probing**

The NCK provides two probing inputs. Application of a signal to either one will cause the actual positions of the axes to be stored in registers, and if programmed to do so, can trigger an interruption of the move.

### **FXSO000535      Structured and symbolic programming**

Structured programming based on symbolic variables makes programs easier to read and understand.

Symbolic variables (1 to 32 characters) can be created and assigned to all ISO functions and used in parametric expressions.

In addition a stack is available to preserve such variables as well as the L variables.

### **FXSO000536      Building a profile table**

This high-level programming function is used to create a table and to store into it the data concerning a contour.

The data in the table can then be accessed in any order, used by structured programming, and optionally modified and then executed.

Typical applications are contour transformation (particular tool compensation), backwards execution etc...

## Tool Functions Standard Tool Functions

### Tool Axis Selection (G16)

Tool Axis Orientation Function G16 with one of the mandatory arguments (P, Q, and R) followed by a plus or minus sign defines the tool axis orientation.

The tool axis can be oriented in six different positions on machines with an interchangeable tool-head.

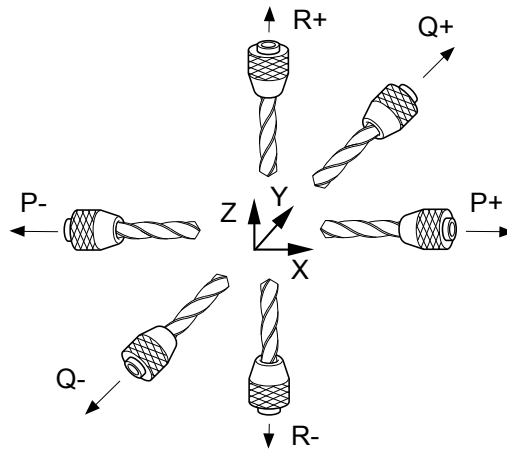

### Tools Offset

**Turning Tools:** The tool length offset is assigned to the tool axis orientation defined by G16. The programmed tool paths are corrected by a value equal to the tool length X and Z defined in the D offset selected.

**Tool Radius Offset:** the programmed tool paths are corrected by a value equal to the tool insert radius based on the tool nose orientation defined by codes C0 to C8 defined in the D offset selected.

- G41 offsets the contour to the left with respect to the direction of movement
- G42 offsets the contour to the right with respect to the direction of movement

Definition of tool nose orientation

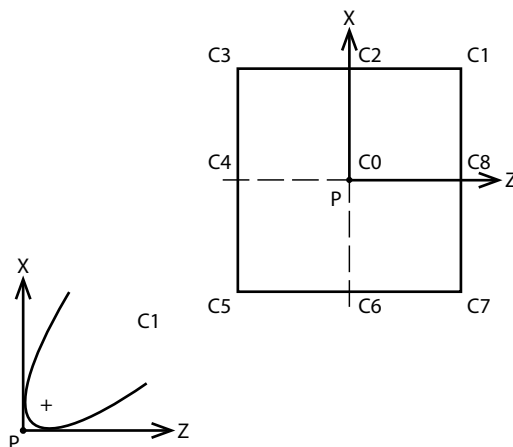

### Milling Tools

The tool length offset is assigned to the tool axis orientation defined by G16. The programmed tool paths are corrected by a value equal to the tool length L defined in the D offset selected.

**Tool Radius Offset:** the programmed tool paths are corrected by a value equal to the tool radius defined in the D offset selected.

- G41 offsets the contour to the left with respect to the direction of movement
- G42 offsets the contour to the right with respect to the direction of movement

### Tool Wear Compensation

It is possible to compensate for slight variations of the tool dimensions. These compensations are taken into account immediately when below a certain amount. They can be entered automatically by the PLC or by the operator (in such case they are incremental).



## Optional Tool Management Functions

### FXSO000400

#### 3D Radius correction (Toroid tools)

With 3D radius correction, the tool axis is parallel to one of the axes of the basic three-axis reference system defined by the tool axis orientation function (G16). Each programmed point is associated with a vector normal to the surface to be machined, defined by its P, Q and R components.

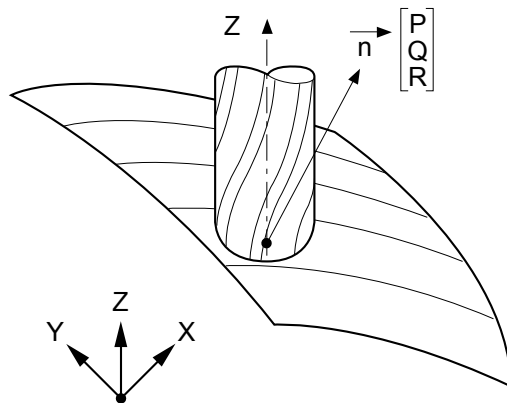

### FXSO000401

#### Extension to 255 offsets

The basic system includes 32 tool offsets for turning systems, and 99 for milling.

The D address followed by a number selects the tool offset.

The tool dimensions are stored in tables and validated according to the programmed axes.

### FXSO000411

#### 5-axis tool radius correction

With 5-axis tool offset, the tool axis can be inclined on machines equipped with a double twist tool head.

Each programmed point is associated with a vector normal to the surface to be machined, defined by components P, Q and R, plus a tool orientation vector defined by components I, J and K, where applicable, which define the angles of the twist head.

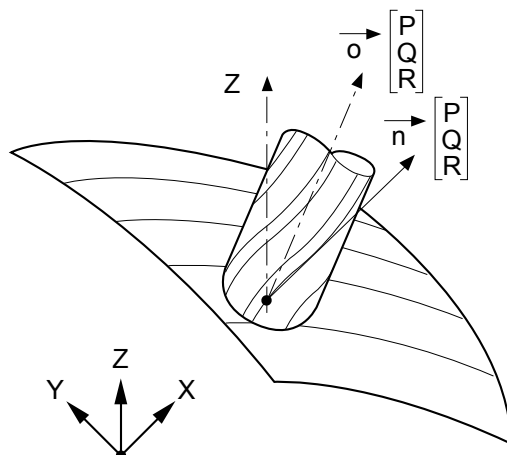



## Machine Operation

---

### **FXSO000082 Auto N/M functionality**

When enabled by the PLC, this function allows the operator to manually control up to five axes while the other axes remain under control of the part program.

The axes which can be controlled manually are selected and deselected by external parameters in the part program. Any command in the program for movement on these axes is then ignored.

If this function is used to mode the milling head axes then RCTP will probably be required.

### **FXSO000505 Emergency retract (G75)**

On receipt of a signal sent to the PLC the current block is immediately interrupted and a jump to a previously specified program sequence is executed.

This feature is widely used on grinding and gear cutting machines.

### **FXSO000523 Backtrack along programmed path**

This function, available on the first channel, is used to backtrack the axis and then return it to the point where the program was interrupted all being made under the operator's control.

On a feed stop command, the operator enables the backtrack-along-path command. As long as the command is active, the axes are moved back along the path at the feed rate programmed in the previously executed and memorized (up to 100). This function is operative in automatic, single-step and dry run modes.

When the operator enables the return command the trajectory is then executed forward up to the point of interruption where the initial mode will be restored.

The program can be resumed ahead of the backtrack point.

Tool offsets and wear offsets less than 0.1 mm can be applied during backtrack and return.

The automatic axis recall function can be used in intervention mode. In this case, the points on the manual backtrack path are stored (maximum 10 points) and restored in the same order in the axis recall phase at the traverse, up to a programmable distance from the restart point.



## Flexium+ Panels

---

The FS153i and FS192i Panels are generally used to run the PLC function and the Flexium+ HMI. In a Flexium+ system one and only one PLC is mandatory, regardless of the number of NCKs. For this reason different versions are available:

- PC panel with PLC function (RTS) and screen
- PC panel without PLC function but with screen (for multi panels systems)
- Panel without PC altogether (terminal for an external PC)

The PC panels are available with a 15" LCD or with a 19" LCD (portrait and landscape).

For the product characteristics, versions, part number and dimensions, see chapter 3.

### Standard HMI Functions

---

Developed in HTML and JavaScript for easier customization, the Flexium+ human-machine interface is based on the renowned Flexium HMI and incorporates a completely new graphic design. Whilst fully operational on a 15" operator panel, it is best experienced on the FS192i operator panel, to take full advantage of its 19" multitouch display and virtual keyboard capabilities.

Flexium+ HMI features 7 contexts, each one of these showing all information required. The different contexts are:

- **PRODUCTION:** Current execution data, Program in progress
- **PROGRAMMING:** Part program management and editing
- **TOOLS:** Entering tool offsets, tool wear management
- **WORK:** Work offsets
- **VARIABLE:** Display of programming (L..., E...) parameters as well as symbolic variables
- **DIAG:** Machine production diagnostic, Error messages, help ...
- **SERVICE:** Protected context for HMI setup and some machine diagnostic
- **sF8, sF9:** Free contexts for customization

Flexium+ HMI includes the basic version of Flexium 3D described below.

---

### Optional HMI Functions

---

#### **FXSW282112**      **Symbolic Names**

This function allows names to be assigned to the channels. These names are displayed instead of the usual address numbers, for example on the axes position page and in the status window.

The channels can be grouped and assigned to a machine. Part programs can be assigned to the channels. Symbolic names can also be assigned to axes and are displayed in the production context.

Symbolic names are used for display purposes. Programming remains in reference with the normalized name of the axes (X, Y, Z...).

#### **FXSW282113**      **Extended Tool Table**

This feature enhances the tool table in the tool context and allows for any tool the addition of:

- A name,
- A comment,
- A channel

This information is saved together with the tool data in one single file.

#### **FXSW282114**      **Teach-In**

This option adds a teach-in function to the editor in the programming context (sF2). The actual axes positions can be transferred easily into an open part-program.

The following settings are possible:

- Selection of the axes to teach
- Extension of the axes positions with CNC functions (G, M, F etc.)
- Insert a block or overwrite an existing block
- Overwrite only the axes positions of an existing block

#### **FXSW282117**      **Multi-NCK**

Flexium+ 68 controls up to 32 axes/spindles dispatched over up to 8 channels. Multi-NCK extends this limit and allows control over several Flexium+ NCKs interconnected through to one single PLC (PC Panel or Box PC). Such systems can drive more than 200 axes/spindles and are typical for NUMtransfer solutions.

For the operator, the several NCKs present themselves as just one machine, making operation clear and simple. In large systems several operating can be used.



## PLC Visualization

---

Flexium+ offers the possibility to create custom screens controlled directly by the PLC application. This is useful for diagnostic or maintenance purpose as well as supervision.

Four versions are available:

### **FXSW282160      PLC Visualization**

This brings the possibility to integrate a custom visualization within a frame of Flexium+ HMI. This integration is possible in:

- The production context (e.g. for a virtual machine panel)
- The two free contexts (sF8 and sF9)

### **FXSW282302      Target Visualization**

The PLC visualization runs on the system that contains the PLC real time monitor (generally the PC Panel). It shows a full screen or sizable image running independently of Flexium+ HMI.

### **FXSW282203      Web Visualization**

This brings the possibility to display a full custom visualization via a web interface (browser).

### **FXSW282300      HMI Classic Visualization**

Similar to Target Visualization above but running on a different PC than the one performing the PLC functions.

### Standard Flexium 3D Functions

---

Flexium 3D is a 3D graphical simulation software for part programs written in ISO-Code (DIN 66025 with NUM dialect), which exists in different versions for milling, drilling and/or turning applications as well as water jet and plasma cutting:

During the part program simulation the path of the TCP (tool center point) is visualized, the material removal on the work piece is simulated and a collision check is made between machine components, part and tools.

Operating the software is oriented on mouse and keyboard usage as well as single and dual touch gestures.

Flexium 3D takes as input the machine configuration (e.g. machine parameter, kinematics and physical parts, tool library, blank and collet definition), offset table and the NC program (part program).

An ISO-parser is integrated inside the host application (simulation), which analyses the part program, makes all tool length and tool radius compensations as well as offset transitions and rotations, and substitutes mill-, drill- and turning cycle definitions with real movements.

The wired path simulation is standard. According to the type of machine (T or M), optionally mixed configurations, material removal as well as collision checking are available.

Two versions are available:

- Office version: used as a standalone program preferred in production planning without CNC (Dongle is needed)
- Machine version: integrated in the Flexium+ HMI for pre-simulation or in online synchronization to the machining

### Optional Flexium 3D Functions

---

#### **FXHE557200 Flexium 3D Dongle**

The dongle is required to run Flexium3D outside a Flexium+ system.

#### **FXSW282150 Simulation for Turning**

The base system should be ordered as a turning or milling system.

#### **FXSW282151 Simulation for Milling**

The base system should be ordered as a turning or milling system.

#### **FXSW282152 Simulation Mixed T & M**

Once the base system is chosen, this option gives the possibility for simulation of both turning and milling.

#### **FXSW282153 Simulation with Material Removal**

The base system displays the tool path. This option also allows the blank part and material removal to be displayed during the process.

#### **FXSW282154 Simulation with Collision Detection**

This feature shows possible collisions during simulation. The software will show the number of collisions, their location on the part (with a red box) and in the part program (blocks highlighted in red). During setup it is possible to select which kind of collision should be detected. In order to work safely, this option will require the machine to be accurately described.

#### **FXSW282155 Online Simulation**

This function is available on the machine version. It allows the simulation to be synchronized to the actual movements of the axes, to show the process in real-time.

# Flexium+ CNC System

System Functions  
Flexium Tools Functions

## Flexium Tools Standard Functions

Flexium Tools is part of the Flexium Suite and includes all functions needed for the integration and commissioning of the machines. Flexium Tools allows users to program, configure and optimise system components within a unique environment:

- PLC
- Flexium NCKs (CNC)
- Servo drives and motors
- Sensors
- EtherCAT and CANopen gateways with a comprehensive set of I/O and logic terminals

## Easy Operation

The menu structure of Flexium Tools provides a perfect overview of the entire system. Navigation inside the device tree is simple and clear, allowing easy access to all functions for quick change of settings.

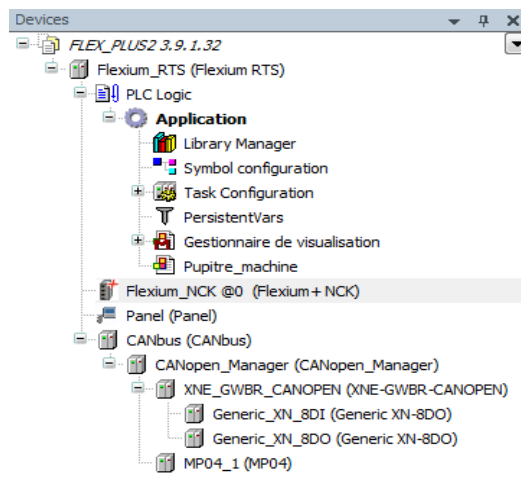

## Project Handling

Access rights can be defined for different users. Each project consists of one single file to ensure easy handling and to prevent data losses. New equipment or versions are quickly integrated using EDS for CANopen devices and Device Descriptions (DevDesc) for NUM devices. Libraries can be used in different versions and can be compiled to protect know-how. Complete projects, including libraries, devices and the source code can be archived, thus making restoration possible at any time in the future.

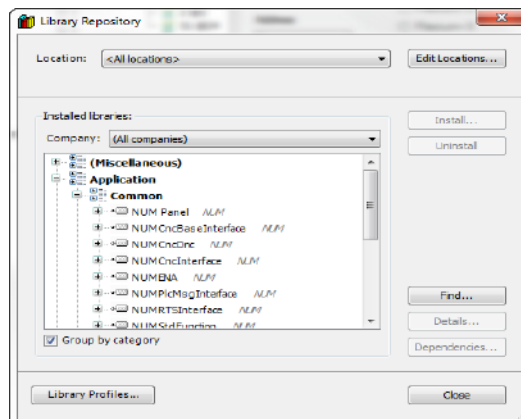

## PLC System Programming

The PLC of the Flexium system is programmed in accordance with IEC 61131-3 and allowed different graphical supported programming environments. For more details see next pages.

## Flexium NCK (CNC) Parameterising

Dedicated editors for options, programming, memory, channels, axes (with individual windows for settings, coupling, kinematics, travels, servo system, HSC) miscellaneous hand wheels, axes calibration and more ensure easy handling and the best overview during editing.

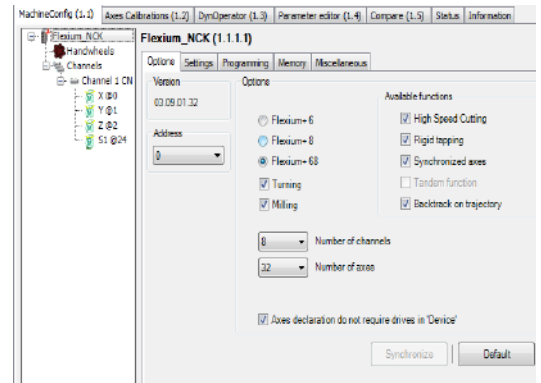

## Servo Drives Parameterising

All servo drives of the Flexium system can be found and accessed easily in the menu structure of Flexium Tools. For better overview, the structure is displayed in the way the system is set up, e.g. servo drives are listed under the controlling Flexium NCK.

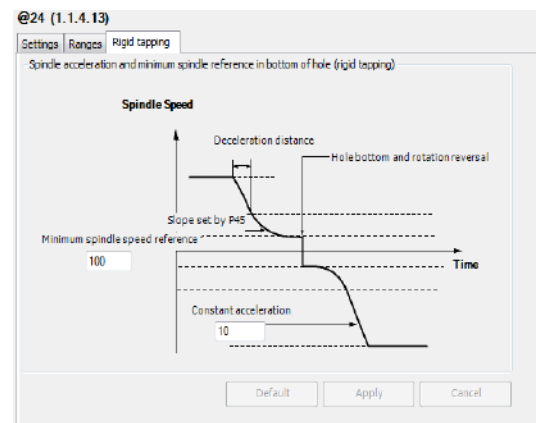
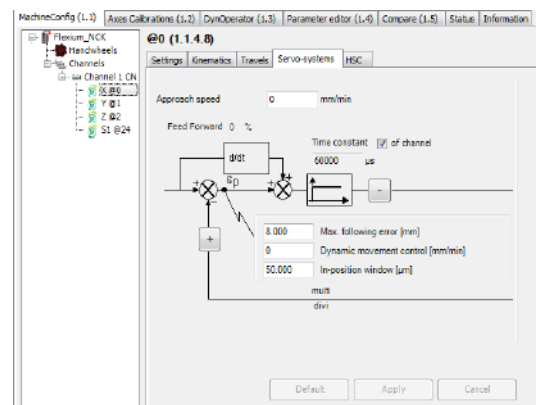

# Flexium+ CNC System

System Functions  
Flexium Tools Functions

## Field Busses

Theoretically, any CANopen and/or EtherCAT compatible device can be connected to the bus using the EDS/ESI/XML file supplied with the device. NUM provides a comprehensive range of most common I/O components based on EtherCAT technology (EtherCAT = Ethernet for Control Automation Technology). It is the real-time Ethernet technology standardized by EtherCAT Technology Group.

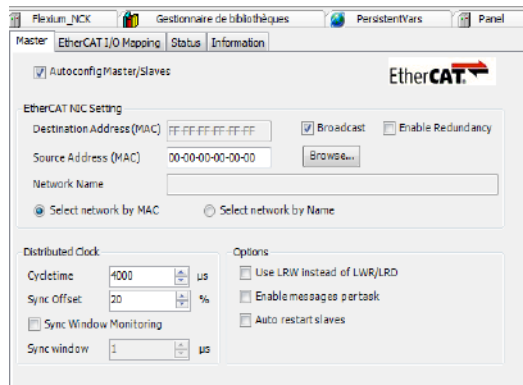

NUM provides machine panels (like MP04), drives for auxiliary axes and other devices that, by means of dedicated windows and libraries, can be easily integrated as field bus devices (CANopen).

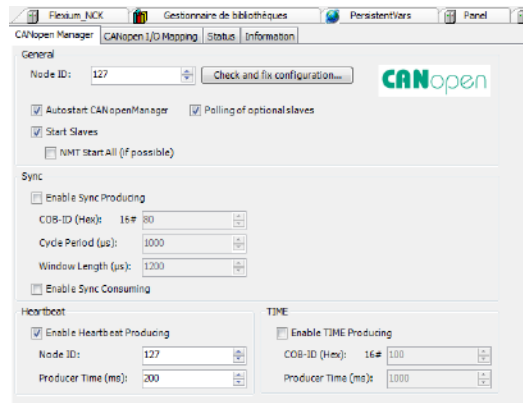

## Instruments

For easy commissioning, a huge set of instruments is available: Frequency Analyser, Ball-Bar, Contour Accuracy Oscilloscope and others.

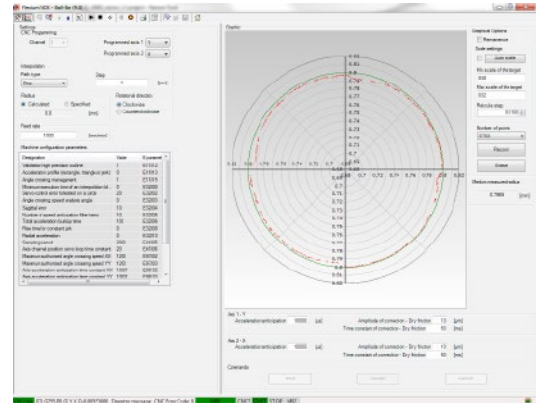

2

## Ball-Bar Function

The ball-bar function is integrated in Flexium Tools. It checks the behavior of the axes and sets the parameters related to the servo drives.

Thanks to circles drawn by G02/G03 or by small segments (Tabcyls), this function generates a diagram of the radial error on the main axes or other axis pairs, which facilitates adjustment of the following parameters:

- Acceleration anticipation coefficient
- CNC reference filter time constant
- Pitch compensation

## Ball-Bar Trace

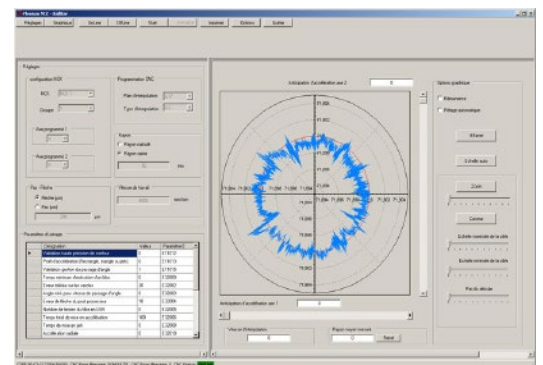

### PLC Programming

The PLC of the Flexium system is programmed in accordance with IEC 61131-3. Thanks to the five programming languages available in Flexium Tools, existing PLC programs written for NUM Power or Axiom Power CNCs can be easily converted.

The logical and easily manageable development environment offers dedicated tools for development, commissioning and maintenance. The PLC program structure is displayed in a logical structure showing the different blocks and folders. The program editors can be opened in the following languages:

- Instruction List (IL)
- Ladder (LD)
- Function Block Diagram (FBD)
- Structured Text (ST)
- Sequential Function Control (SFC)

The PLC provides libraries for system functions, customer functions and its own programming functions.

Task management is very comfortable and can be cyclic, event-controlled or freewheeling.

Data and variables are based on a high level language such as C. Data types can also be user defined.

The program can be easily structured using program building blocks, functions and function blocks with entities.

Object oriented programming is also supported and allows safe programs using objects, methods, properties, actions, interfaces and inherit functions.

#### PLC in a Multi-NCK System

A multi-NCK system for large systems can consist of up to 16 NCKs connected to a single PLC.

This concept ensures the highest performance and makes configuration as well as operation simple and easy. Even large multi-NCK systems - such as transfer machines - present themselves to the programmer and the operator as one single system.

```
PROGRAM ENA_Axespositions_OP
VAR
  R_Axis_OP_active:BOOL; // R_Axis_OK test active
  // axes positions by axes-address
  Q_R_Axis_OP_0:R_Axis_OP;
  Q_R_Axis_OP_1:R_Axis_OP;
  Q_R_Axis_OP_2:R_Axis_OP;
  Q_R_Axis_OP_3:R_Axis_OP;
  Q_R_Axis_OP_4:R_Axis_OP;
  Q_R_Axis_OP_5:R_Axis_OP;
  Q_R_Axis_OP_6:R_Axis_OP;
  Q_R_Axis_OP_7:R_Axis_OP;
  Q_R_Axis_OP_8:R_Axis_OP;

1 IF (Flexium_NCK.CommunicationReady) THEN
2
3   IF R_Axis_OP_active THEN
4
5     //*****
6     // axes positions by axes- address
7     //*****
8     // Settings for axis position reading
9     Q_R_Axis_OP_0(CNCAdr:=ADR(Flexium_NCK), byChannel:=0);
10    Q_R_Axis_OP_0.enable :=TRUE;
11    IF (Q_R_Axis_OP_0.uiResult = 0) THEN
12      g_di_Axis_OP(0,0):=Q_R_Axis_OP_0.Axis[0].Position;
13      g_di_Axis_OP(0,1):=Q_R_Axis_OP_0.Axis[1].Position;
14      g_di_Axis_OP(0,2):=Q_R_Axis_OP_0.Axis[2].Position;
15      g_di_Axis_OP(0,3):=Q_R_Axis_OP_0.Axis[3].Position;
16      g_di_Axis_OP(0,4):=Q_R_Axis_OP_0.Axis[4].Position;
17      g_di_Axis_OP(0,5):=Q_R_Axis_OP_0.Axis[5].Position;
18      g_di_Axis_OP(0,6):=Q_R_Axis_OP_0.Axis[6].Position;
19      g_di_Axis_OP(0,7):=Q_R_Axis_OP_0.Axis[7].Position;
20      g_di_Axis_OP(0,8):=Q_R_Axis_OP_0.Axis[8].Position;
21    END_IF
22
23    Q_R_Axis_OP_1(CNCAdr:=ADR(Flexium_NCK), byChannel:=1);
```

### Optional Functions

There is no option required to develop any case of Flexium+ application.

### Flexium+ PLC Standard Functions

---

Flexium+ PLC is a software PLC running under a real time system (RTS) and therefore largely independent of Windows. Flexium+ PLC runs on NUM devices (PC Panels FS153i or FS192i or Box PC). Consult us for other hardware.

---

### Flexium+ NC/PLC Exchanges

---

Communication with the NCK through RTE (Real Time Ethernet) exchange of process data like:

- **General Read Data**
    - Current modes, JOG increments, CNC error number, CNC active, external parameters
    - CNC and machine status
    - Active program number
    - Axes data (initialized, moving, clamped, axis state)
    - Spindles (status, speed)
  - **Channel Specific Read data**
    - Channel states, G functions, current modes
    - Encoded M functions without acknowledgement, on-the-fly
    - Encoded M functions with acknowledgement
    - 34 decoded M functions
    - Tool number
  - **General Write Data**
    - Control of axis jogs, mode control, error messages
    - Selection of channels, program numbers
    - Processing of spindles, potentiometers, commands, set points
    - Inhibiting of certain modes, jog commands, feed rates
    - Torque and reference enable for digital axes
    - External parameters
  - **Channel Specific Write Data**
    - Machine functions
    - Axis feed-rate override potentiometer for all channels
- 

### Flexium+ PLC/Machine Exchanges

---

Flexium+ PLC communicates with the machine via a field bus or CANopen or EtherCAT. The First CANopen interface is standard on Flexium+ 68.

---

### Flexium+ PLC Optional Functions

---

#### **FXSW282124      Extended NCK Access**

This function provides the option of accessing NC Data which are not exchanged cyclically (e.g. current axes' positions, machine parameters, all external parameters, ...) as well as providing access to the part program memory for uploading, downloading, memory available, directory.

#### **FXSO000430      First CANopen Interface**

Connection and license for a first CANopen bus. This feature is standard on Flexium+ 68.

#### **FXSO000432      Second CANopen Interface**

Connection and license for a second CANopen bus. This feature is only available on Flexium+ 68.

#### **NVRAM Memory for Systems with CANopen**

Access to 56 Kb of NVRAM memory for PLC variables. This feature depends on the type of PC-Panel ordered.

---

# Flexium+ CNC System

System Functions  
NUMSafe

## NUMSafe Architecture

The NUMSafe architecture is based on a Safe PLC (CTMP6900), Safe I/Os (CTMS2904 and CTMS1904) and NUM-SAMX connected through the EtherCAT field bus. The safe PLC contains the programmed logic of the safety application, while the safe motion monitoring functions are handled by NUM-STO and NUM-SAMX module built into NUMDrive X servodrives (see chapter 5).

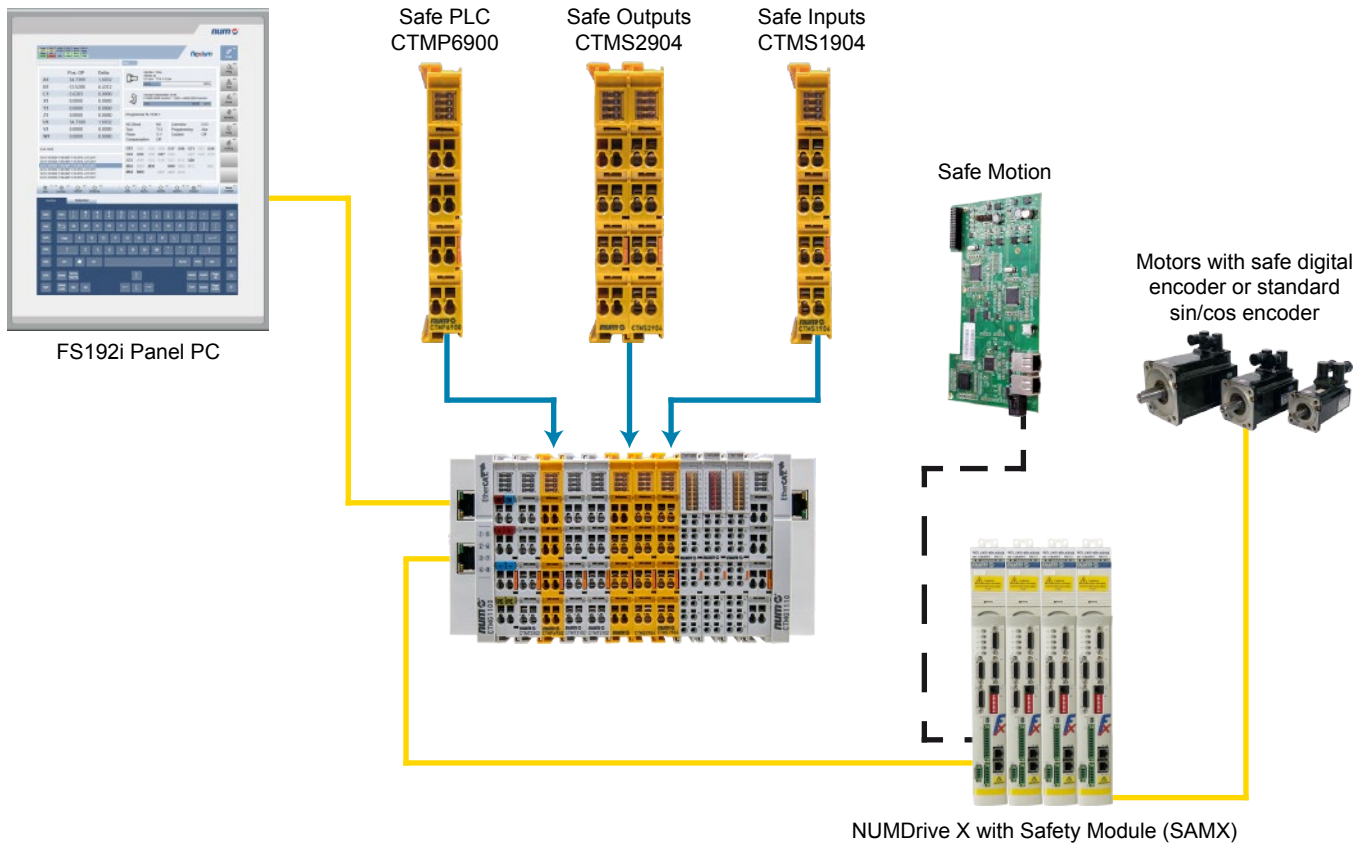

NUMSafe is a comprehensive solution for the functional safety management of each machine type. Architectures with mixed standard and safety related signals are possible (the safe PLC and I/Os can be positioned inside a standard terminal line up). All safety related and NON safety related data are transferred over the standard EtherCAT connection (FSoE), reducing wiring to the minimum and maximizing flexibility and scalability.

The safety related devices are configured and programmed by means of the Flexium Tools.

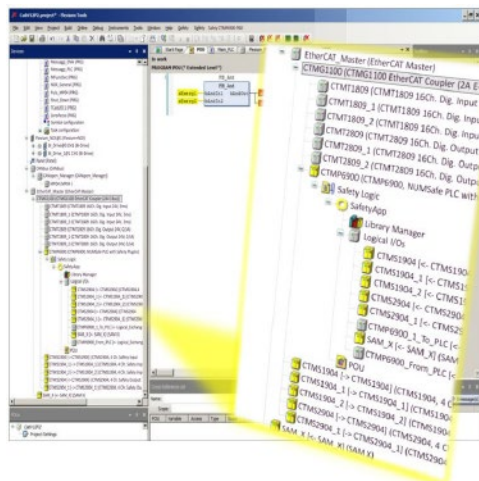

NUMSafe is compliant with EN 13849-1 and EN61800-5-2 up to PL e and SIL 3 respectively.

### NUMSafe Standard PLC Functions

NUMSafe PLC can establish 128 connections to other NUMSafe devices. Multiple NUMSafe PLCs are cascadeable within a network. Safety functions such as emergency stop, safety door monitoring, two-hand control, etc. can thus easily be selected and linked. All blocks can be freely connected among each other and are complemented by operators such as AND, OR, etc. The required functions are configured via Flexium Tools and loaded into the CTMP6900 NUMSafe PLC via the fieldbus.

The available function blocks are:

#### FB\_AND

Using the FB\_AND function block, several input signals can be ANDed to make an output signal. In addition, a setting can be made for each input as to whether it is to be negated. This can be switched over using the "Negation" command from the context menu.



#### FB\_CS

A NUMSafe connection can be deactivated via the FB\_CONNECTION SHUTDOWN function block. If the input of the block becomes active the connection is terminated, a shutdown command is sent to the FSoE partner and a feedback signal is provided at the output. Furthermore, the connection is terminated and the output is set if a shutdown command is received from the communication partner.



#### FB\_DECOUPLER

The FB\_DECOUPLE function block serves to decouple signals from a NUMSafe connection. The function block has 8 inputs and 8 outputs, wherein the inputs are looped through to the outputs one-to-one. The corresponding output must be linked as soon as one of the inputs of the block is used. This also applies in the reverse direction.



#### FB\_EDM

The FB\_EDM function block (External Device Monitor) monitors the signals bMon1 and bMon2 over time. A switch-on and a switch-off monitor can be configured. In the default condition both monitors are inactive.



#### FB\_ESTOP

An emergency stop circuit with up to eight emergency stop inputs (bEStopIn1 - bEStopIn8) can be implemented with the FB\_EStop function block. Each of the eight inputs can be negated using the "Negation" command from the context menu. As soon as an input requests the safe state, the first output (EStopOut) immediately enters the safe state ("0") and the second output (EStop-DelOut) enters the safe state after a configurable time delay.

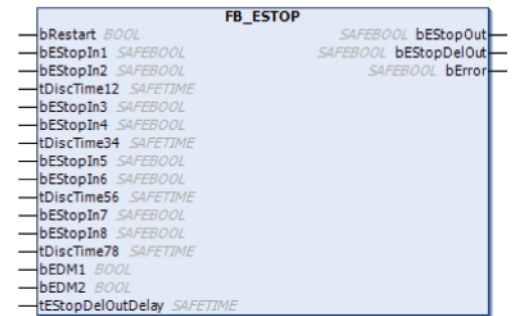

#### FB\_MON

A safety door circuit with up to four inputs (bMonIn(x)), for example, can be implemented with the FB\_MON function block. Each of the four inputs can be realized as a normally closed contact (break contact - 0 requests the safe state) or as a normally open contact (make contact - 1 requests the safe condition). As soon as an input requests the safe state, the first output (bMonOut) immediately enters the safe state ("0") and the second output (bMonDelOut) enters the safe state after a configurable time delay. By linking the FB output to several outputs, several immediately switching-off outputs (bMonOut) or delayed switching-off outputs (bMonDelOut) can be implemented with just one FB\_Mon.

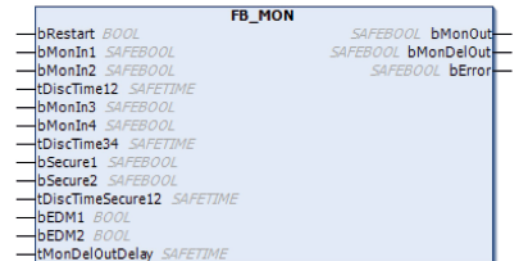

### FB\_MUTING

The FB\_Muting function block implements an intended suppression of the safety function e.g. for the transport of material into the safety area. The output of the function block remains set even though the connected sensors are interrupted.

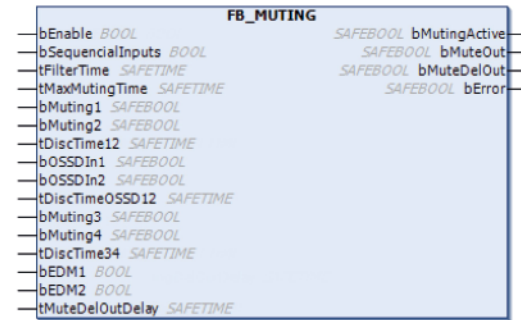

### FB\_MODE

Operating mode selector switches can be implemented with the FB\_MODE function block. The function block has 8 inputs and 8 outputs, which are looped through one-to-one, whereby up to 8 different modes of operation can be selected. The FB\_MODE sets the corresponding output only if precisely one input is set ("1"); the other outputs remain in the safe state ("0"). If no input is set or if more than one is set, all outputs are in the safe state. If the bRestart input is activated, the safe state of the outputs is quit at the start and when changing the operating mode only via a 0->1->0 signal sequence at the Restart input. Beyond that a discrepancy time can be specified at the tDiscTime input with which the change from one mode of operation to the next is monitored.

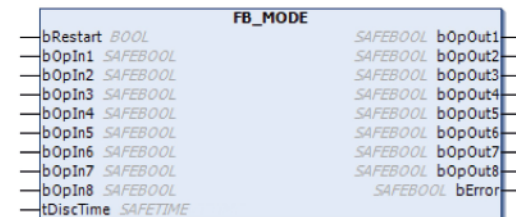

### FB\_OR

Using the FB\_OR function block, several input signals can be ORed to make an output signal. In addition, a setting can be made for each input as to whether it is to be negated. This can be set using the "Negation" command from the context menu.



### FB\_RS

The FB\_RS function block realizes a Reset/Set function. A logic 1 at the bSafeSet input and logic 0 at the bSafeReset input leads to a logic 1 at the output. A logic 0 at the bSafeSet input and logic 1 at the bSafeReset input leads to a logic 0 at the output. If both inputs are at logic 1, the Reset signal is dominant and leads to a logic 0 at the output. If both inputs are at logic 0, the output remains in its current state.

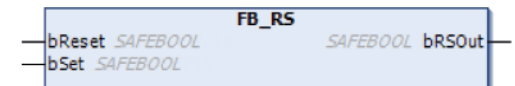

### FB\_SR

The FB\_SR function block realizes a Set/Reset function. A logic 1 at the bSafeSet input and logic 0 at the bSafeReset input leads to a logic 1 at the output. A logic 0 at the bSafeSet input and logic 1 at the bSafeReset input leads to a logic 0 at the output. If both inputs are at logic 1, the Set signal is dominant and leads to a logic 1 at the output. If both inputs are at logic 0, the output remains in its current state.

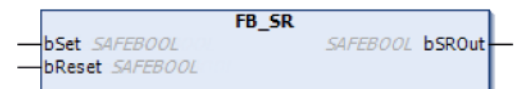

### FB\_TOF

A switch-off delay is realized with the FB\_TOF function block. A logic 1 at the bTofIn input is extended by the set time and forwarded to the output. If the input is set to 1 again before the switch-off delay time is reached, the output remains switched on. The error output is inactive, since the block does not set errors.



### FB\_TON

A switch-on delay is realized with the FB\_TON function block. A logic 1 at the bTonIn input is extended by the set time and forwarded to the output. If the input is set to 0 again before the delay time is reached, the output is not switched on. The error output is inactive, since the block does not set errors.



### FB\_TWOHAND

The FB\_TWOHAND block implements a two-hand circuit in which both input groups must be actuated at the same time in order to switch the output. Renewed setting of the output is only possible if both input groups are at logic 0 at the same time.





### NUMDrive X Standard Functions

#### Motor Type and Control Method

NUMDrive X accommodates open- and closed-loop control of different motor types:

- Closed loop with current vector control: synchronous rotary motors
- Closed loop with current vector control: synchronous torque and linear motors (optional for Bi-Axes drives, High Performance version is needed: MDLUX---B1C----)
- Closed loop with current vector control: asynchronous motors
- Open loop with current vector control: asynchronous motors
- Open loop in V/f mode: asynchronous motors

#### Motor Sensor

NUMDrive X can interoperate with different motor feedback types:

- Stegmann Hiperface encoder
- Heidenhain EnDat 2.1 & EnDat 2.2 encoder
- 1 Vpp toothed wheel / encoder
- Single cable motor sensor (encoder used in SHX, SPX motors)
- Renishaw RESOLUTE™ encoder with BiSS interface
- Magnescale encoder

#### High Performance Control Loop

NUMDrive X features high internal resolution, a short sampling time (20 kHz) and specially developed control algorithms, which all contribute to its very wide bandwidth (optional for Bi-Axes drives, High Performance version is needed: MDLUX---B1C----). The drive's wide bandwidth ensures exceptional dynamic performance, as well as precision and stiffness at the mechanical interface of the machine.

#### Direct Measure Sensor (optional for Bi-Axes drives High Performance version is needed: MDLUX---B1C----)

NUMDrive X can interoperate with different direct measure sensor:

- EnDat 2.1 & EnDat 2.2 encoder / linear scale
- Hall sensors
- 1 Vpp encoder / linear scale (also with coded references)
- Renishaw RESOLUTE™ encoder with BiSS interface
- Magnescale encoder

#### EPS: Electrical Position Synchronization

To drive synchronous motors correctly, the relative position of the rotor (or magnet plates for linear motors) has to be known; this is typically realized by using and configuring absolute encoders (single or multi-turn). The EPS function allows incremental encoders to be used for this purpose; detection of the rotor (or magnet plates for linear motors) position is realized at each power on.

#### Spindle-Axis Commutation, Star/Delta Commutation on the Fly

NUMDrive X manages synchronous and asynchronous motors either as axis feed or as spindle feed. Furthermore, each axis can become a spindle and vice versa. For each operation mode a dedicated parameter set is defined in order to optimize the motor working conditions and the sensor configuration.

For asynchronous motors, NUMDrive X supports on-the-fly star/delta commutation.

#### AP01: Absolute Position with Motor's Multi-Turn Encoder and Incremental Direct Measure Sensor

The AP01 function allows the absolute position of an axis to be obtained from its motor's multi-turn encoder; the incremental direct measure sensor is initialized during initialization of the CNC-drive system.

The CNC won't require the homing on the axis even if the direct measure sensor is not absolute.

### AP02: Rotary Axes with Mechanical Ratio Different from 2n

The AP02 function provides absolute position management (without the need to perform the HOMING procedure), even in the case of rotary axes with a mechanical ratio between the motor sensor (or direct measure sensor) and the load which is not 2n. The function also allows machine lengths that exceed the maximum number of encoder revolutions to be managed as an absolute axis.

### AP06: Coherence Control between Motor and Direct Measure Sensor

The AP06 function controls the coherence between a motor and its direct measure sensor; its parameters define the maximum accepted displacement and the minimum time for which the displacement is accepted.

### Digital Filters

Various digital filters are available, which can be freely set and cascaded to act at different points in the control loop. Types include first or second order low/high pass and notch filters, which can be applied to any combination of torque reference, speed reference and/or speed feedback.

### AP12: Active Dumping

As well as digital filters which can be used to dump mechanical resonances, the active dumping function is a complex closed loop algorithm particularly suitable for smoothing low frequency vibrations (below 150 Hz).

## NUMDrive X Optional Functions

### AP03 FXSO100453: Anti-Backlash Function

Rack and pinion kinematic solutions usually have an unacceptable backlash; mechanical solutions to reduce backlash exist, but they decrease the efficiency of the transmission significantly, and deteriorate over time due to wear. A better approach is provided by the NUMDrive X anti-backlash function, which uses two motors to drive the same rack; the motors and rack are preloaded to compensate for the backlash. The function can be used for linear or rotary axes.

For implementing the anti-backlash function the following is needed:

- NCK Option FXSO100453
- A Bi-Axes drive in High Performance version is needed: MDLUX---B1C----
- Two Mono-Axis drives with dedicated version: MDLUX---A1D----

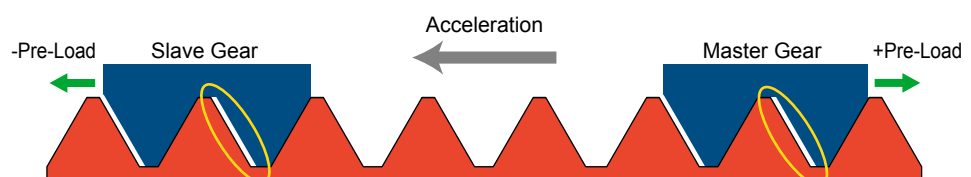

During strong acceleration phases, the needed thrust is higher than the pre-load: both motors/gears are thrusting in the same direction.

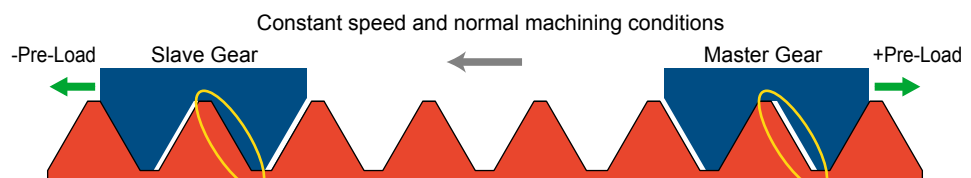

At constant speed, standstill and during machining, the pre-load compensates the backlash. The master position is the reference one.

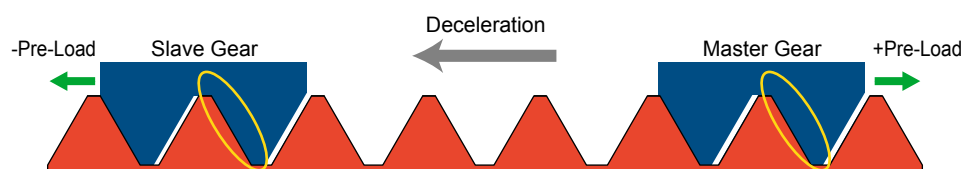

During strong deceleration phases the master gear recovers the backlash and retains the load.

### AP04 FXSO100453: Tandem Function

Similar to the anti-backlash function, this allows two or more drives/motors to be electronically connected so that the torque/force supplied to the rack is the sum up of all motor forces.

### AP05 FXSO100454: Winding Duplication

Some specialized applications demand very high power motors (>>100 kW), with their windings divided into N independent sets. With NUMDrive X it's possible to drive such independent windings by using N drives; the drives are hard synchronized so that the system performance is equivalent to a motor driven by one drive only.

- NCK Option FXSO100454
- A Bi-Axes drive in High Performance version is needed: MDLUX---B1C----
- Two Mono-Axis drives with dedicated version: MDLUX---A1D----

---

## NUMDrive X Standard Safety Functions

---

As standard, NUMDrive X servodrives are equipped with the NUM-STO safety feature. This provides the Safe Torque Off function as specified by the EN 61800-5-2.

When the STO function is activated NUMDrive X will not provide the motor with any energy that could generate torque (or force in the case of a linear motor).

---

## NUMDrive X Optional Safety Functions

---

The safe monitoring of axes' speed and position is carried out by NUM-SAMX safety module. NUM-SAMX interoperates by means of the EtherCAT (and FSoE) with the NUMSafe PLC and I/Os. NUM-SAMX is a hardware option of NUMDrive X; please refer to chapter 8 for part number definition.

NUM-SAMX performs the following safety functions:

### Safe Torque Off (STO)

Like NUM-STO, NUM-SAMX provides the STO function but in this case the activation of the function is performed by means of the NUMSafe PLC and FSoE.

When the STO function is activated NUMDrive X will not provide the motor with any energy that could generate torque (or force in the case of a linear motor).

### Safe Operational Stop (SOS)

The SOS function prevents the motor from deviating more than a defined amount from the stopped position. The NUMDrive X provides energy to the motor to enable it to resist external forces.

### Safe Stop 1 (SS1)

The SS1 function monitors the motor deceleration rate within set limits to stop the motor and initiates the STO function when the motor speed is below a specified limit.

### Safe Stop 2 (SS2)

The SS2 function monitors the motor deceleration rate within set limits to stop the motor and initiates the safe operating stop function when the motor speed is below a specified limit.

### Safe Limited Speed (SLS)

The SLS function prevents the motor from exceeding specified speed limit(s).

### Safe Limited Position (SLP)

The SLP function prevents the axes from exceeding specified position limit(s).

### Safe Direction Monitoring (SDM)

The SDI function prevents the motor shaft from moving in an unintended direction.

### Safe Interlock Signal

NUM-SAMX provides a safe signal to indicate whether the motor speed is below a specified limit.

# Flexium+ CNC System

Flexium+ Options Grid Summary Table  
Flexium+ Main Component Summary

## Flexium+ Main Component Summary

	Flexium+ Main Component Summary
PC Panel with PLC Function	FS153i or FS192i with RTS, real time system FS153 or FS192L + Industrial Box PC
Machine Panel <sup>3</sup>	MP04 (FXHE558xxx) <sup>1</sup> MP05 (FXHE558xxx)
Handheld Terminal <sup>3</sup>	nPad (NPAD052RE1SH0D1)
Portable Handwheel <sup>3</sup>	HBA (FXHE181xxx)
NCK	Flexium NCK <sup>2</sup>
I/Os System	NUMEtherCAT gateway and terminals (CTMG1100 + CTMTxxxx)
Safe PLC and Safe I/Os <sup>3</sup>	NUMSafe PLC and terminals (CTMP6900, CTMS2904, CTMS1904)
Safe Motion Functions	NUMDrive X with NUM-SAMX option (MDLUXxxxx1xSN0x)
Digital CNC Servodrives	NUMDrive X (MDLUXxxxx1xxN0x)
Digital PLC Servodrives (CANopen)	NUMDrive C (MDLU3xxxxCxxN0x) <sup>1</sup>
Servo Motors	SHXxxxxx
	SPXxxxxx
	BHXxxxxx
	BPXxxxxx
	BPHxxxxx
	BPGxxxxx
Spindle Motors	AMSxxxxx
	IMxxxxx

<sup>1</sup> CANopen card needed for FXPCxxxxx and Flexium option (FXSO000430 / FXSO000432) needed too

<sup>2</sup> Base component of a Flexium system – additional units required in Multi-NCK configuration

<sup>3</sup> Optional

# Flexium+ CNC System

## Flexium+ Options Grid Summary Table Basic Characteristics



### Basic Features and Optional Extensions

	Flexium+ 6	Flexium+ 8	Flexium+ 68
<b>Axes + Spindle (digital and analog)</b>			
Base	5 <sup>1</sup>	5 <sup>2</sup>	5
Optional max	-	-	6 to 32
<b>Interpolated Axes per Channel</b>			
Base	4	4	4
Optional max	-	-	9
<b>Channels</b>			
Base	1	1	1
Optional max	-	2	8
<b>Handwheels</b>			
Base	0	0	0
Optional max	2	2	4
<b>CANopen Interfaces</b>			
Base	0	0	1
Optional max	1	2	2

<sup>1</sup> up to 4 axes and 1 spindle

<sup>2</sup> up to 5 axes or 4 axes and 1 spindle

2

# Flexium+ CNC System

## Flexium+ Options Grid Summary Table Machine Configuration



### Machine Configuration

	Reference	Flexium+ 6	Flexium+ 8	Flexium+ 68
<b>Platforms</b>				
Flexium+ 6	FXP1101100	●	-	-
Flexium+ 8	FXP1101150	-	●	-
Flexium+ 68	FXP2101200	-	-	●
<b>Configuration <sup>1</sup></b>				
Turning	FXSO200060	○	○	○
Milling	FXSO200061	○	○	○
<b>Multi-NCK</b>				
System Multi-NCK	FXSW282117	-	-	○
<b>Axes, Spindles or Measure inputs <sup>2</sup></b>				
6th axis/spindle	FXSO100006	-	-	○
7th and 8th axes/spindles	FXSO100008	-	-	○
9th to 12th axes/spindles	FXSO100012	-	-	○
13th to 16th axes/spindles	FXSO100016	-	-	○
17th to 32th axes/spindles	FXSO100032	-	-	○
Analog interface 1 for axis or spindle	FXSO100373	○	○	○
Analog interface 2 for axis or spindle	FXSO100374	○	○	○
<b>Handwheels <sup>3,4</sup></b>				
Handwheel interface 1	FXSO100375	○	○	○
Handwheel interface 2	FXSO100376	○	○	○
Handwheel interface 3	FXSO100377	-	-	○
Handwheel interface 4	FXSO100 378	-	-	○
<b>Interpolation capability</b>				
5th interpolated axis	FXSO100335	-	-	○
6th interpolated axis	FXSO100336	-	-	○
7th interpolated axis	FXSO100337	-	-	○
8th interpolated axis	FXSO100338	-	-	○
9th interpolated axis	FXSO100339	-	-	○
<b>Channels</b>				
2nd channel	FXSO100392	-	○	○
3rd + 4th channel	FXSO100394	-	-	○
5th + 6th channel	FXSO100396	-	-	○
7th + 8th channel	FXSO100398	-	-	○

<sup>1</sup> The choice must be specified with the order

<sup>2</sup> Each axis, spindle or measurement unit requires a port

<sup>3</sup> Handwheels are either connected on an analog interface or as a CANOpen device. When connected on an analog interface, it is not necessary to order a measure input for it

<sup>4</sup> It is not possible to connect more than two devices (including handwheels) on the analog interfaces

● Standard      ○ Optional      – Not Available

# Flexium+ CNC System

## Flexium+ Options Grid Summary Table Axes, Spindle and Machining Functions

### Axes and Spindle Functions

	Reference	Flexium+ 6	Flexium+ 8	Flexium+ 68
<b>Axes functions</b>				
Duplicated and synchronized axes	FXSO000266	-	○	○
Inclined or tilted axes	FXSO000315	-	○	○
Conversion Cartesian to polar/cylindrical	FXSO000340	-	○	○
NURBS (B-Spline) interpolation	FXSO000426	-	-	○
Tandem function	FXSO000453	-	○	○
Circular interpolation by three points	FXSO000497	-	○	○
Smooth polynomial interpolation	FXSO000499	-	○	○
Radial axis boring / milling function (U-axis)	FXSO000514	-	○	○
Spline-Interpolation (G06, G48, G49)	FXSO000518	-	○	○
Programmable precision	FXSO000519	-	-	○
<b>Spindle functions</b>				
Spindle synchronization	FXSO000156	-	○	○
Axis/spindle synchronization	FXSO000331	-	○	○
Rigid Tapping	FXSO000332	-	○	○
<b>Machining functions</b>				
RTCP (Rotation Tool Center Point)	FXSO000154	-	-	○
High speed cutting	FXSO000155	-	○	○
Tilted nozzle management	FXSO000404	-	○	○
Combined machine (turning + milling)	FXSO000581	-	-	○
Automatic gear-alignment	FXSO000595	-	○	○
Milling and standard pocket cycles	FXSO000695	-	-	○
Turning cycles	FXSO000696	-	-	○
Inclined plane machining	FXSO000914	-	-	○
Polygon-cutting cycles	FXSO100538	-	-	○
Probing cycles for turning	FXSO100590	-	○	○
Probing cycles for milling	FXSO100591	-	○	○

#### Common features for all systems:

- Linear and circular interpolation
- Helical interpolation in milling systems
- Axes and Inter-axes calibration
- Progressive acceleration
- Anti-pitch correction
- Spindle indexing
- Spindle range automatic search

● Standard      ○ Optional      – Not Available



### Programs, Tools, Operation

	Reference	Flexium+ 6	Flexium+ 8	Flexium+ 68
<b>Programming functions</b>				
Dynamic operators in C	FXSO000249	-	○	○
Dynamic operators	FXSO000250	-	○	○
Scaling factor (G74)	FXSO000506	-	○	○
Angular program offset (ED)	FXSO000507	-	○	○
Recording current parameters values	FXSO000511	-	○	○
On the fly measurement / probing	FXSO000520	-	○	○
Structured and symbolic programming	FXSO000535	-	○	○
Building a profile table	FXSO000536	-	○	○
<b>Tools functions</b>				
3D Radius correction (Toroid tools)	FXSO000400	-	○	○
Extension to 255 offsets	FXSO000401	-	○	○
5 Axes tool radius correction	FXSO000411	-	-	○
<b>Machine operation</b>				
Auto N/M functionality	FXSO000082	-	-	○
Emergency retract (G75)	FXSO000505	-	○	○
Backtrack along programmed path	FXSO000523	-	○	○

#### Common features for all systems:

- Parametric programming
- Profile Geometric Programming
- Inch / Metric conversion
- 32 Tool offsets
- Radius and length compensation
- Tool wear offset by the PLC
- Tool axis selection

# Flexium+ CNC System

## Flexium+ Options Grid Summary Table PLC Functions

### PLC Functions

	Reference	Flexium+ 6	Flexium+ 8	Flexium+ 68
First CAN Interface	FXSO000430	○	○	●
Second CAN interface	FXSO000432	-	○	○
Multi NCK	FXSW282117	-	-	○
Extended NCK access	FXSW282124	○	○	○
PLC Visualization <sup>1</sup>	FXSW282160	○	○	○
HMI Classic <sup>2</sup>	FXSW282300	○	○	○
Target visualization <sup>3</sup>	FXSW282302	○	○	○
Web Visualization <sup>4</sup>	FXSW282303	○	○	○

<sup>1</sup> PLC Visualization allows for integrating PLC controlled pages in a frame of Flexium+ HMI

<sup>2</sup> HMI Classic: PLC controlled visualization displayed on a remote device

<sup>3</sup> Target visualization: PLC controlled visualization displayed on the same device than the one running the PLC.  
Contrary to the PLC visualization the screen are separated from Flexium HMI

<sup>4</sup> Web visualization: PLC controlled visualization displayed inside a browser on an external device

● Standard      ○ Optional      – Not Available

# Flexium+ CNC System

## Flexium+ Options Grid Summary Table Options Packages

### Options Packages - Description

For an optimal system configuration, the options can be regrouped in different technology packs. The list below defines the packs and their availability according to each system.

		Reference	Flexium+ 6	Flexium+ 8	Flexium+ 68
<b>T</b>	Turning Pack	FXPA000555	○	○	○
<b>M0</b>	Basic Milling Pack	FXPA000560	○	○	○
<b>M1*</b>	Milling Pack	FXPA000561	-	-	○
<b>M2*</b>	Milling Pack	FXPA000562	-	-	○
<b>M3*</b>	Milling Pack	FXPA000563	-	-	○
<b>HSC*</b>	HSC Milling Pack	FXPA000564	-	-	○
<b>AM</b>	Aluminum Machining Pack	FXPA000 566	-	-	○
<b>CUT*</b>	Water-jet, plasma cutting	FXPA000 567	-	-	○
<b>W1*</b>	Woodworking Pack	FXPA000576	-	-	○
<b>TR</b>	Tool grinding Pack	FXPA000586	-	-	○
<b>GS</b>	Surface Grinding Pack	FXPA000587	-	○	○
<b>GC</b>	Cylindrical Grinding Pack	FXPA000588	-	○	○
<b>GTWG</b>	Threaded Wheel Gear Grinding Pack	FXPA000589	-	○	○
<b>GH1</b>	Gear Hobbing Pack 1	FXPA000596	-	○	○
<b>GH2</b>	Gear Hobbing Pack 2	FXPA000597	-	○	○

\* Pack M0 is required

● Standard      ○ Optional      – Not Available

# Flexium+ CNC System

## Flexium+ Options Grid Summary Table Options Packages

### Pack Contents

	Reference	M0	M1*	M2*	M3*	HSC*	T	TR	GH1	GH2	GTWG	GC	GS	W1*	AM*	CUT*
RTCP	FXSO000154			○	○									○	○	○
High speed cutting	FXSO000155					○								○		
Axis/Spindle synchronisation	FXSO000331						○				○	○				
Rigid tapping	FXSO000332		○		○											
5 axis interpolation	FXSO000335			○	○			○						○	○	
3D radius Compensation	FXSO000400		○		○									○		
255 Tools offsets	FXSO000401	○	●	●	●	●								●	●	●
Tilted head management	FXSO000404															○
5 axis tool Compensation	FXSO000411			○	○	○								○		
3 pts circular interpolation	FXSO000497	○	●	●	●	●	○	○				○	○	●	●	●
Polynomial Interpolation	FXSO000499					○										
Emergency retract	FXSO000505								○	○	○	○	○			
Scaling factor	FXSO000506	○	●	●	●	●	○					○	○	●	●	●
Angular offset	FXSO000507	○	●	●	●	●	○					○	○	●	●	●
Recording parameters	FXSO000511	○	●	●	●	●	○	○	○	○	○	○	○	●	●	●
Spline interpolation	FXSO000518					○										
Programmable precision	FXSO000519							○				○	○			
Probing on the fly	FXSO000520	○	●	●	●	●	○	○	○	○	○	○	○	●	●	●
Structured programming	FXSO000535	○	●	●	●	●	○	○	○	○	○	○	○	●	●	●
Gear alignment	FXSO000595										○					
NUMgear hobbing cycles	FXSO000690								○	○						
NUMgear threaded wheel grinding cycles	FXSO000691										○					
Milling cycles	FXSO000695	○	●	●	●	●							○	●	●	●
Turning cycles	FXSO000696						○					○				
Full Electronic Gear Box	FXSO000697									○	○					
Simple Electronic Gear Box	FXSO000698								○							
Inclined plane	FXSO000914		○	○	○										○	
Flexium CAM engine	FXSW282180								○	○	○					
NUMgear HMI hobbing	FXSW282220								○	○						
NUMgear HMI threaded wheel gear grinding	FXSW282221										○					
Up to 8 channels	FXSO100398 + 392 394 396											○	○			

Packs marked with a \* require either pack M0 or T.  
○ option included in the pack  
● option implied by the mandatory pack (M0 or T)

# Flexium+ CNC System

## Flexium+ Options Grid Summary Table Applications



### Applications

The following table lists applications that were developed for a special purpose and could be tailored to suit new applications. Please consult us for detailed information.

	Reference	Flexium+ 6	Flexium+ 8	Flexium+ 68
Waterjet: feed control (G120)	FXSW283001	○	○	○
Gap control	FXSW283004	○	○	○
Kinematics transformation for NUMcut head	FXSW283005	-	-	○
Parameter exchange in in CNC/drives by PLC	FXSW283007	○	○	○
Spindle axis synchronization by NCK	FXSW283008	○	○	○

● Standard      ○ Optional      – Not Available

# Flexium+ CNC System

## Flexium+ Options Grid Summary Table HMI Functions



### HMI Functions

	Reference	Flexium+ 6	Flexium+ 8	Flexium+ 68
<b>HMI Features</b>				
Symbolic names	FXSW282112	○	○	○
Extended tool table	FXSW282113	○	○	○
Teach-in	FXSW282114	○	○	○
NUMtransferCNC	FXSW282200	○	○	○
NUMtransferCNC (Multi-CNC)	FXSW282201	-	-	○
<b>Flexium3D options</b>				
3D Simulation with material removal	FXSW282153	○	○	○
3D Simulation with collision detection	FXSW282154	○	○	○
Online simulation	FXSW282155	○	○	○
3D Machine editor	FXSW282156	○	○	○
<b>Visualization options</b>				
PLC Visualization	FXSW282160	○	○	○
CoDeSys Option: Target Visualization	FXSW282302	○	○	○
CoDeSys Option: WEB Visualization	FXSW282303	○	○	○
CoDeSys Option: HMI classic	FXSW282300	○	○	○

2

● Standard      ○ Optional      – Not Available

# Flexium+ CNC System

## Flexium+ Options Grid Summary Table NUMDrive X Functions

### NUMDrive X Functions

		Bi-Axes SP	Mono-Axis HP	Bi-Axes HP
Interface	High speed digital bus DISC NT+	•	•	•
Control Performance	Standard performance control loops	•	•	•
	High performance control loops	-	•	•
Compatible Motors	Closed loop: synchronous rotary motors	•	•	•
	Closed loop: synchronous torque and linear motors	-	•	•
	Closed loop: asynchronous motors	•	•	•
	Open loop: asynchronous motors (V/F mode)	•	•	•
Compatible Motor Sensor	Hiperface encoder	•	•	•
	Single cable motor encoder (SHX, SPX motors)	•	•	•
	EnDat 2.1 & EnDat 2.2 encoder	•	•	•
	1 Vpp toothed wheel / encoder	•	•	•
	Renishaw RESOLUTE™ encoder w/ BiSS interface Magnescale encoders	• •	• •	• •
Compatible Direct Measure Sensors	EnDat 2.1 & EnDat 2.2 encoder / linear scale	-	•	•
	Hall sensors	-	•	•
	1 Vpp encoder / linear scale (also with coded references)	-	•	•
	Renishaw RESOLUTE™ encoder w/ BiSS interface Magnescale encoders	- -	• •	• •
Special Functions	Spindle operation for synchronous and asynchronous motors	•	•	•
	Synchronous motor phasing without movement	•	•	•
	Spindle-Axis commutation	•	•	•
	Star/Delta commutation on the fly (for asynchronous motor)	-	•	•
	Rotary axis with mechanical ratio not 2x	•	•	•
	AP03: Anti-backlash function	-	○	○
	AP04: Torque duplication	-	○	○
	AP05: Winding duplication	-	○	○
	DEM-X: Drive Embedded Macro	-	○	○
	Coherence control between motor and direct measure sensor	-	•	•
	Various active dumping functions	-	•	•
	Various freely settable filters	•	•	•
	EPS: Electrical Position Synchronizaton	-	•	•
AP01: Absolute position with motor's multi-turn encoder and incremental direct measure sensor	-	•	•	

• Standard      ○ Optional      – Not Available

# Flexium+ CNC System

## Flexium+ Options Grid Summary Table NUMDrive X Functions



### NUMDrive X Functions

		Bi-Axes SP	Mono-Axis HP	Bi-Axes HP
Safety Functions compliant with EN 61800-5-2	NUM-STO module with Safe Torque Off	○	○	○
	NUM-SAMX module with	○	○	○
	- STO Safe Torque Off			
	- SLS Safely Limited Speed			
	- SOS Safe Operational Stop			
	- SS1 Safe Stop 1			
	- SS2 Safe Stop 2			
	- SLP Safe Limited Position			
- SDM Safe Direction Monitoring				

2



# Operator Panels and Industrial PC

## Table of Contents

	Page
<b>FS192i Operator Panels with Integrated iPC</b>	<b>71</b>
Technical Characteristics	73
Outlines	74
Ordering Codes	77
<b>FS153i Operator Panels with Integrated iPC</b>	<b>78</b>
User Interface Options	79
Technical Characteristics	80
Outlines	81
Ordering Codes	83
<b>FS192L, FS153 and FS122 Operator Panels</b>	<b>84</b>
<b>FS192L Operator Panel</b>	<b>85</b>
Technical Characteristics	86
Outlines	87
Ordering Code	90
<b>FS153 Operator Panels</b>	<b>91</b>
User Interface Options	91
Technical Characteristics	92
Outlines	93
Ordering Codes	95
<b>FS122 Operator Panels</b>	<b>96</b>
User Interface Options	96
Technical Characteristics	97
Outlines	98
Ordering Codes	99
<b>MP05 Machine Panel</b>	<b>100</b>
Outlines	101
Ordering Code	102
<b>MP04 Machine Panel</b>	<b>103</b>
Options	104
Technical Characteristics	105
Outlines	106
Ordering Codes	107
<b>Industrial Box PC</b>	<b>108</b>
Technical Characteristics	111
Outlines	112
Ordering Codes	114
<b>nPad</b>	<b>115</b>
Product Overview	116
Technical Characteristics	117
Outlines	119
Ordering Codes	120
<b>HBA-X Portable Handwheel</b>	<b>121</b>
Technical Characteristics	123
Outlines	124
Ordering Codes	125



# Operator Panels and Industrial PC

## FS192i Operator Panels with Integrated iPC

### FS192i Operator Panels with Integrated iPC

With the latest 19-inch projected capacitive touch screen system, NUM has set a new standard for operating panels in the machine tool industry. A compact and scalable panel PC with Intel's i5 allows entry to multi-processor technology with Windows 8 operating system.

The FS192i operator panel provides a durable, modern front end for machine control. It has an IP65 degree of protection at the front, and IP20 at the rear. High-quality 4 mm hardened safety glass protects the front, without introducing any disturbing reflections.

A narrow brushed aluminum frame with rounded edges provides complete side protection for the glass and multi-touch sensor.



3

# Operator Panels and Industrial PC

## FS192i Operator Panels with Integrated iPC

### FS192i Virtual Keyboards

The Flexium+ HMI, in conjunction with the FS192i operator panel, offers three virtual keyboards which provide reliable and cost-effective alternatives to their physical counterparts.

#### Virtual QWERTY Keyboard

Available in 5 languages, the virtual QWERTY keyboard implements a complete set of standard alphanumeric, function and scroll keys.



#### Virtual ISO Programming Keyboard

This dedicated virtual ISO programming keyboard provides users with fast access to common ISO commands. The layout and functions of the keys can be easily customized by the user.

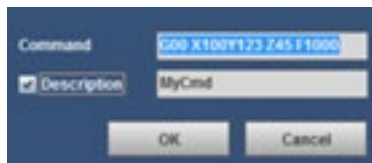

#### Virtual Machine Panel

Available as an option, this soft-key version of a complete machine panel eliminates the need for a physical machine panel such as the MP04, helping to reduce system costs significantly.



# Operator Panels and Industrial PC

## FS192i Operator Panels with Integrated iPC Technical Characteristics

### FS192i (with Integrated iPC) Technical Characteristics

FXPC192CN2Hxx00		
<b>Screen</b>	User interface options	Projected capacitive touch screen with hardened glass protection
	Technology	19" TFT LCD (16.9 million colours)
	Resolution	1024 x 1280 from 60Hz to 75Hz (vertical orientation)
	Size	304 x 379mm
	Backlight	Contr. 400:1 (Typ)
<b>Main PC Features</b>	CPU	i5 M520 2.4GHz Dua ICore
	RAM	SATA DDR3 2 GB
	Mass storage	SATA Hard disk ≥ 260 GB
	Operating system	Windows Embedded 8 Standard
	Graphic card	Intel® HD Graphics
<b>Communication Interfaces</b>	Ethernet (ETH)	2 x GbE LAN / RTE, 1 USB to LAN
	USB rear (x4)	V2.0 - 1.5/12/480 MBit/s, USB Type A
	Serial interface	COM1, COM2, (x2), RS232 D-Sub 9 pole male
	Dual CAN1 / CAN2 (optional)	max. 500 kBaud (isolated); 1 MBaud non isolated
	Dual CAN + NVRAM (optional)	max. 500 kBaud (isolated); 1 MBaud non isolated.
	DVI interface	1
	CRT monitor (VGA)	1
	Line IN/Line OUT MIC	Yes
<b>Power Supply</b>	Rated voltage	24 VDC SELV, safety extra low voltage. Protection class III.
	Voltage range	24 VDC 20.4...28.8 VDC rms / rated for 4A continuous load
	Protection against reverse polarity	Yes
	Protection against over voltage	Yes
	Potential isolation	No. (The 0V-pin of the PS is connected to the digital GND)
	Power consumption	50 W. As point of reference, the 24V-power supply should be rated for 4A continuous load.
<b>Ambient Conditions</b>	Climatic conditions operation	5..45 °C with vertical mounting with Hard disk. 5..35 °C with mounting up to max. 35° with Hard disk. 10...90 % rel. air humidity, non-condensing.  The measuring point is defined 5cm over the top of the PC case in the middle of the vent holes. It is recommended to ensure enough air circulation.
	Climatic storage conditions	-20...60 °C, 10...90 % rel. air humidity, non-condensing
	Climatic conditions, transport	Class 2K3 EN50178 (reduced) -20...60 °C, 10...90 % rel. Air humidity, non-condensing.
<b>EMC</b>	EMC immunity	Industry EN 61000-6-2
	EMC emission	Residential area EN 61000-6-3
<b>Degree of Protection</b>	Front	IP 65
	Rear	IP 20
<b>Weight</b>		11.2 kg
<b>Dimensions</b>	W x H x D	Please refer to the following pages.
<b>Fan</b>	Type	The Smart Fan control system supports Thermal® and Speed® cruise.
<b>Noise</b>		<70dB

# Operator Panels and Industrial PC

## FS192i Operator Panels with Integrated iPC Outlines

### FS192i (with Integrated iPC) Outlines

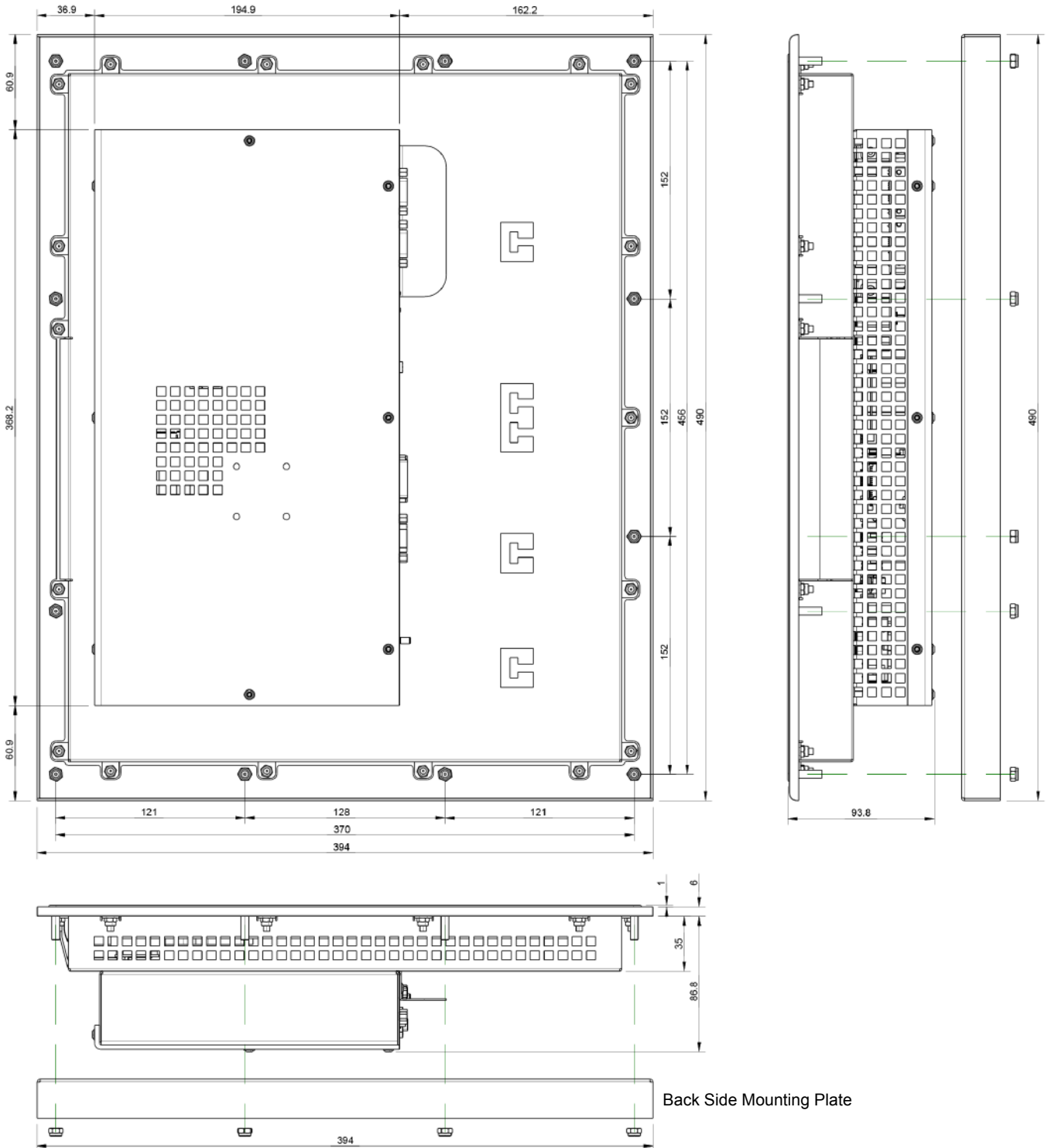

# Operator Panels and Industrial PC

FS192i Operator Panels with Integrated iPC  
Outlines



## FS192i (with Integrated iPC) Cut-Out and Hole Patterns

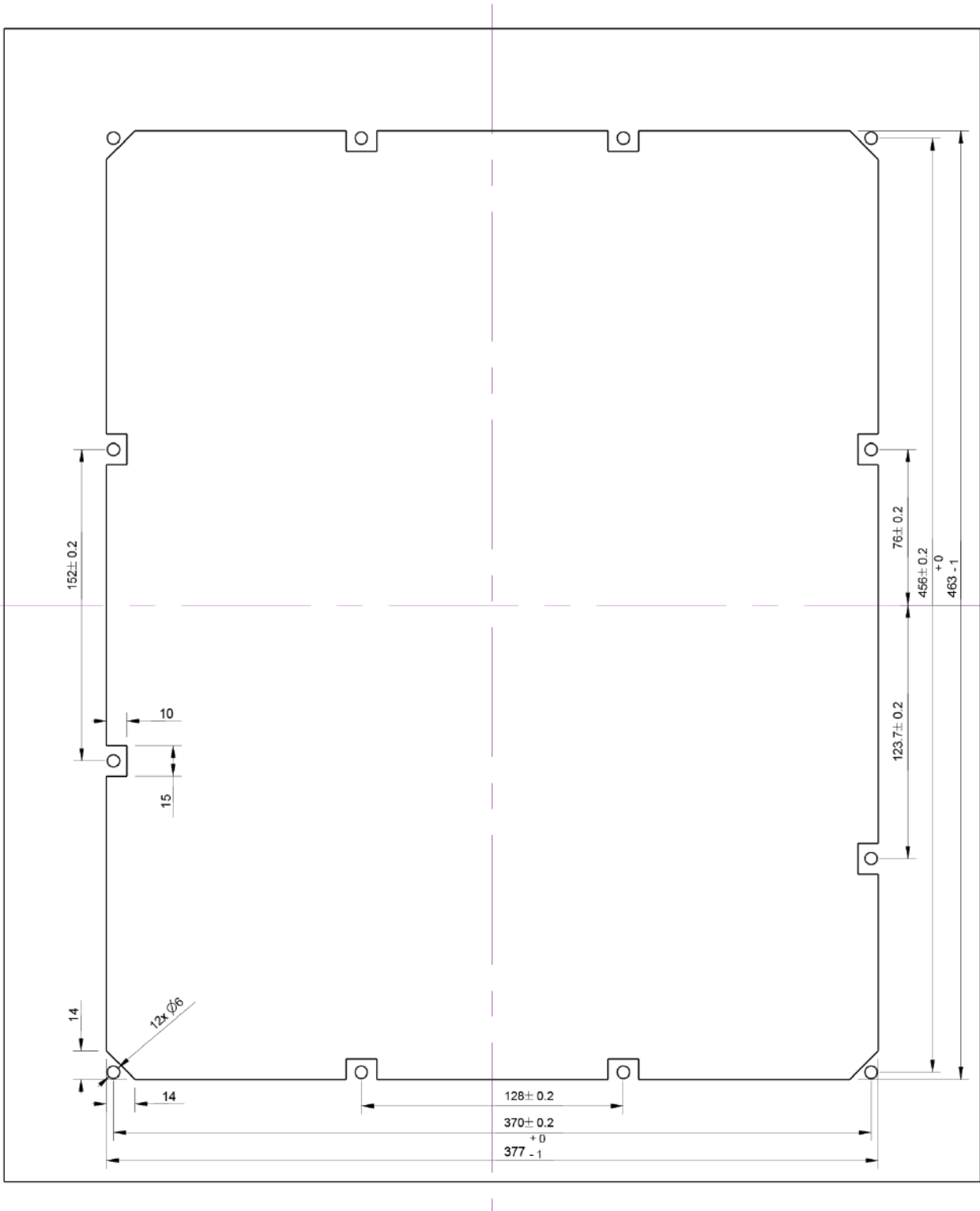

# Operator Panels and Industrial PC

## FS192i Operator Panels with Integrated iPC Outlines

### FS192i (with Integrated iPC) Cut Out when using Back Side Mounting Plate

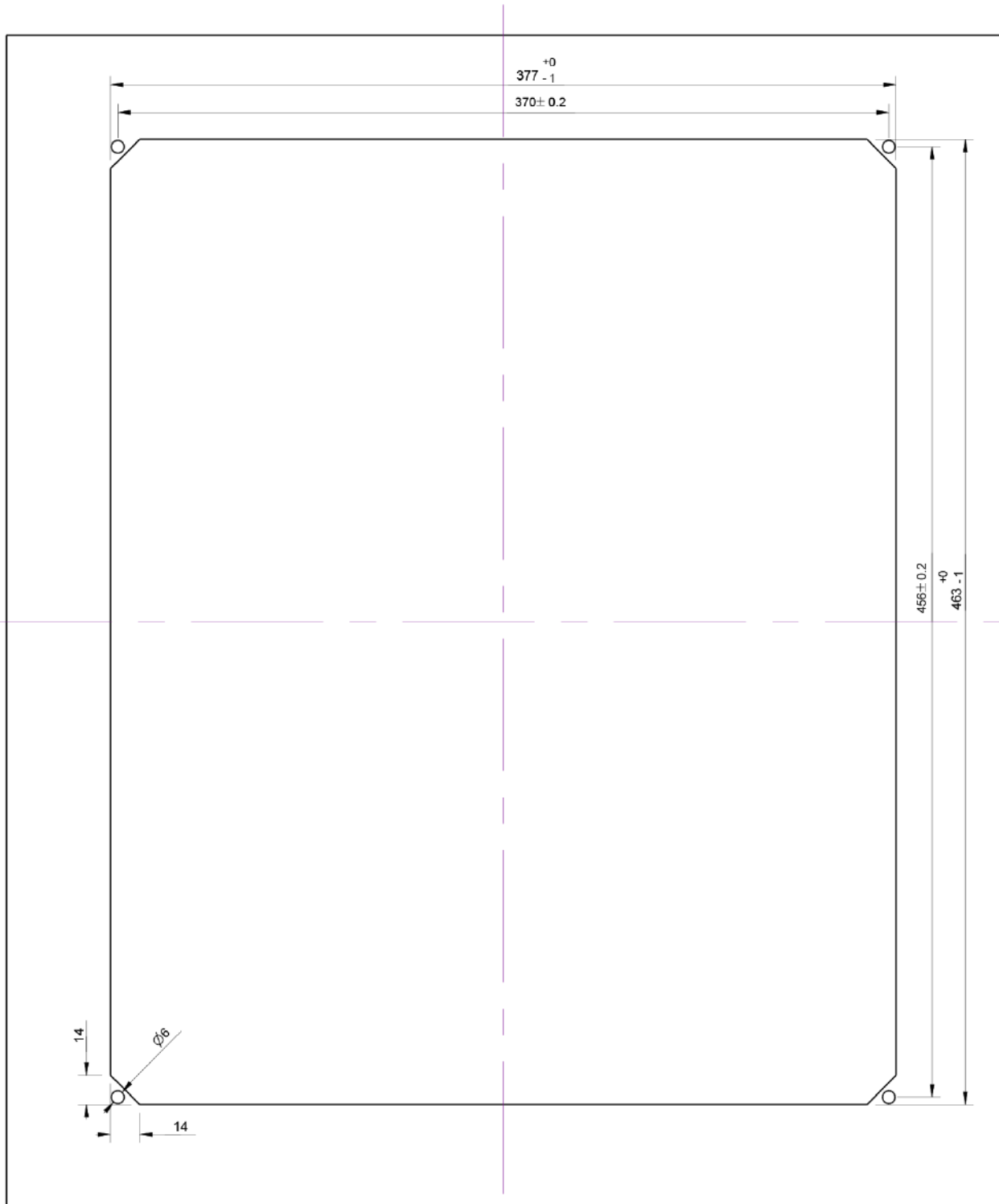

Cut-out in case of using back side mounting plate.

# Operator Panels and Industrial PC

## FS192i Operator Panels with Integrated iPC Ordering Codes

### Operator Panel FS192i Available Versions

FS192i Version	Ordering Codes
FS192i-TS P2 HD NR	FXPC192CN2HNN00
FS192i-TS P2 HD RT	FXPC192CN2HNR00
FS192i-TS P2 HD RT CAN	FXPC192CN2HCR00
FS192i-TS P2 HD RT CAN NVRAM	FXPC192CN2HDR00

	FXPC	19	2	C	N	2	H	D	R	1	0
<b>Display Unit</b>											
- LCD 19"		19									
<b>Panel/Mechanical Variant</b>											
- Second generation			2								
<b>Display Sensor</b>											
- Touch screen (proj.) capacitive				C							
<b>Keyboard Type</b>											
- No keyboard, no function keys					N						
<b>IPC Mother Board, Processor</b>											
- Performance level P2						2					
<b>Mass Memory Type</b>											
- HD (hard disk)							H				
<b>Option Board</b>											
- No fieldbus									N		
- CAN									C		
- CAN + NVRAM									D		
<b>Flexium RTS</b>											
- Real time										R	
<b>Operating System</b>											
- Windows 8 Kernel											1
<b>Spare Number</b>											0

3

# Operator Panels and Industrial PC

## FS153i Operator Panels with Integrated iPC

### FS153i Operator Panels with Integrated iPC

NUM has developed control panels either with or without an integrated industrial PC. Please refer to page 91 for details of the control panel without an integrated PC.

FS153i PC panels provide a powerful and ergonomic platform for the Flexium+ HMI, enabling you to interact with the machine in a simple and logical manner. The integrated PCs use modern dual-core processors. Two performance levels are available: P1 and P2 (see page 80 for details).

Depending on the application, you can choose the user interface:

- With 22 large function keys (keyboard option F)
- With 22 large function keys and an expanded QWERTY keyboard (keyboard option Q)
- Touch screen available as option

The display quality of their 15.1" screen makes the panels very legible even in poorly-lit environments. Compact and very rugged, the panels are sealed (IP65) and suitable for use in severe industrial environments.

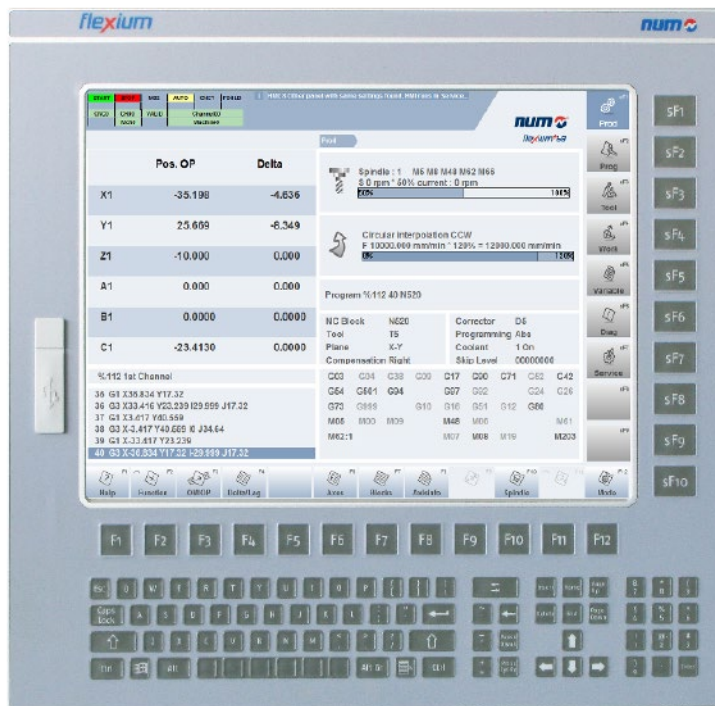

# Operator Panels and Industrial PC

## FS153i Operator Panels with Integrated iPC User Interface Options

### FS153i User Interface Options



Panel with 22 Function Keys  
(Reference with PC Panel coding «F»)

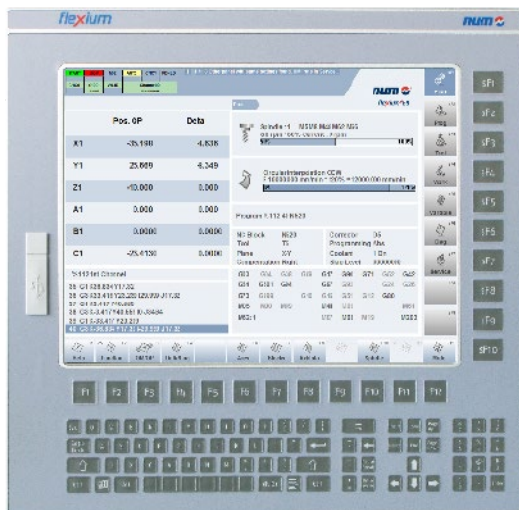

Panel with 22 Function Keys and QWERTY-Keyboard  
(Reference with PC Panel coding «Q»)

3

# Operator Panels and Industrial PC

## FS153i Operator Panels with Integrated iPC Technical Characteristics

### FS153i (with Integrated iPC) Technical Characteristics

		<b>FXPC153NF1Cxxxx</b> <b>FXPC153NQ1Cxxxx</b>	<b>FXPC153NF2Hxxxx</b> <b>FXPC153NQ2Hxxxx</b> <b>FXPC153RF2Hxxxx</b> <b>FXPC153RQ2Hxxxx</b>
Screen	User interface options	Active panel with integrated PC with: - 22 Function Keys - 22 Function Keys and Qwerty Keyboard - Touch Screen (resistive)	
	Technology	15" TFT LCD (16.9 million colors)	
	Resolution	1024 x 768 from 60Hz to 75Hz	
	Size	304 x 228 mm (12 x 9 inch)	
	Backlight	LED, Contr. 700:1 (Typ)	
Main PC Features	CPU	Atom™ D525 1.8 GHz Dual Core	i5-2510E 2.5 GHz Dual Core
	RAM	2 GB	2 GB
	Mass storage	8 GB SLC Compact Flash	250 GB Hard Disk
	Operating system	WES 2009	Win. Embedded 8.1 Industry Pro
Communication Interfaces	Ethernet (ETH)	3 x Gigabit LAN / RTE	3 x Gigabit LAN / RTE
	USB front	1 x USB Type A	
	USB rear	2 x USB Type A	6 x USB Type A
	Serial interface	3 x COM	No
	Dual CAN + NVRAM	Optional	
	DVI interface	No	1
	CRT monitor	1 x VGA	No
	DisplayPort	No	2
Power Supply	Line IN/Line OUT MIC	Yes	
	Rated voltage	24VDC (+15%/-15%) SELV	24VDC (+15%/-15%) SELV
	Protection against reverse polarity	Yes	
	Protection against over voltage	Yes	
	Potential insulation	No, the 0V pin is connected to the digital GND	
Environmental Conditions	Power consumption	ca. 20 W	ca. 45 W
	Climatic conditions, operation	0..45°C, 70% rel. air humidity, non-condensing	
	Climatic conditions, storage	-40...80°C, 70% rel. air humidity, non-condensing	
Degree of Protection	Climatic conditions, transport	-20...60°C, 90% rel. air humidity, non-condensing	
	Front	IP 65	
	Rear	IP 20	
Weight	Pollution degree	2	
		ca. 6.1 kg Function Key version ca. 6.5 kg Full Qwerty version	
Dimensions	W x H x D	410 x 330 (400) x 72.3 mm	
Cooling Type		Internal with fan	

# Operator Panels and Industrial PC

## FS153i Operator Panels with Integrated iPC Outlines

### FS153i (with Integrated iPC) Outlines

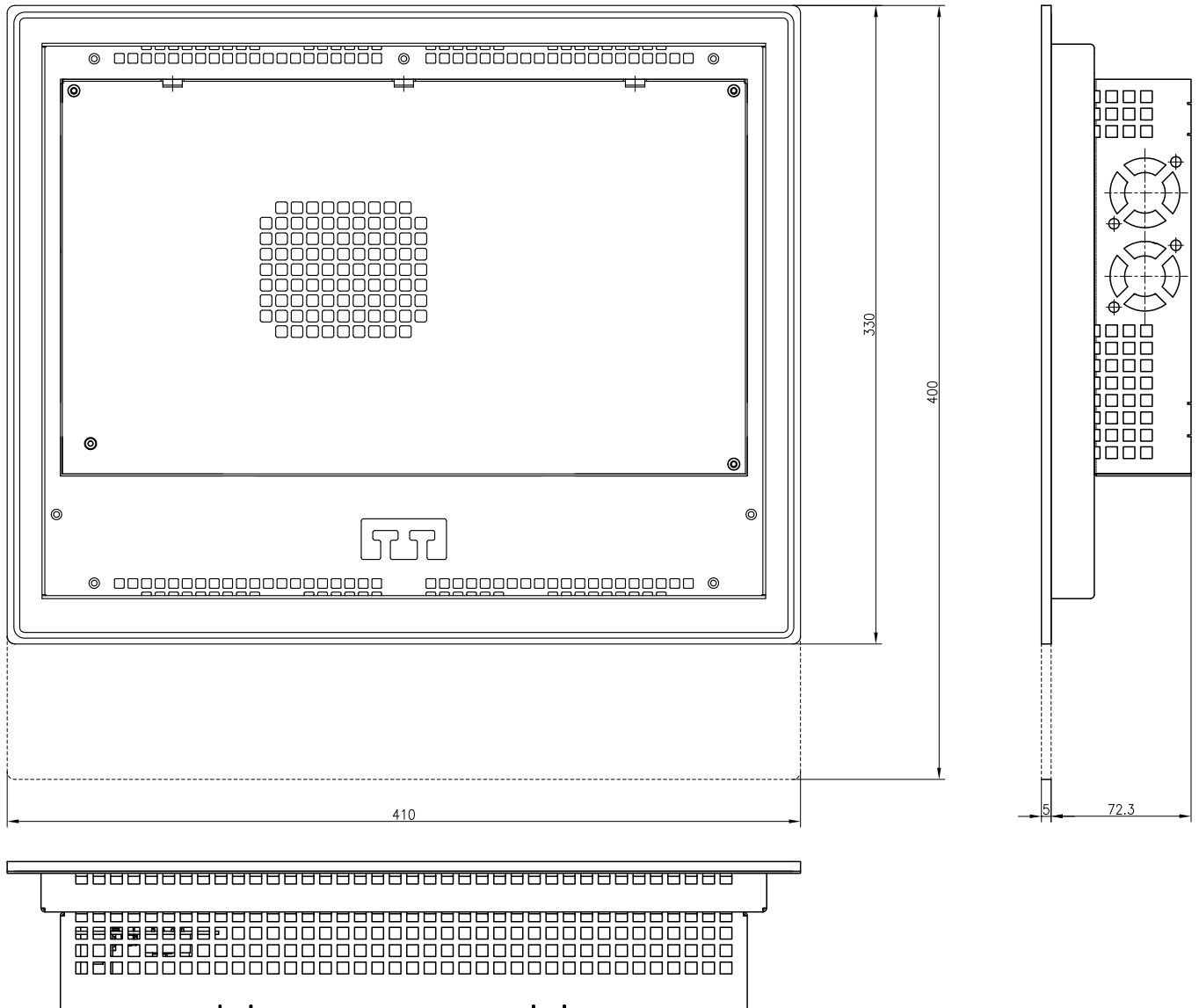

3

# Operator Panels and Industrial PC

FS153i Operator Panels with Integrated iPC  
Outlines



## Operator Panel FS153i Cut-Out and Hole Pattern

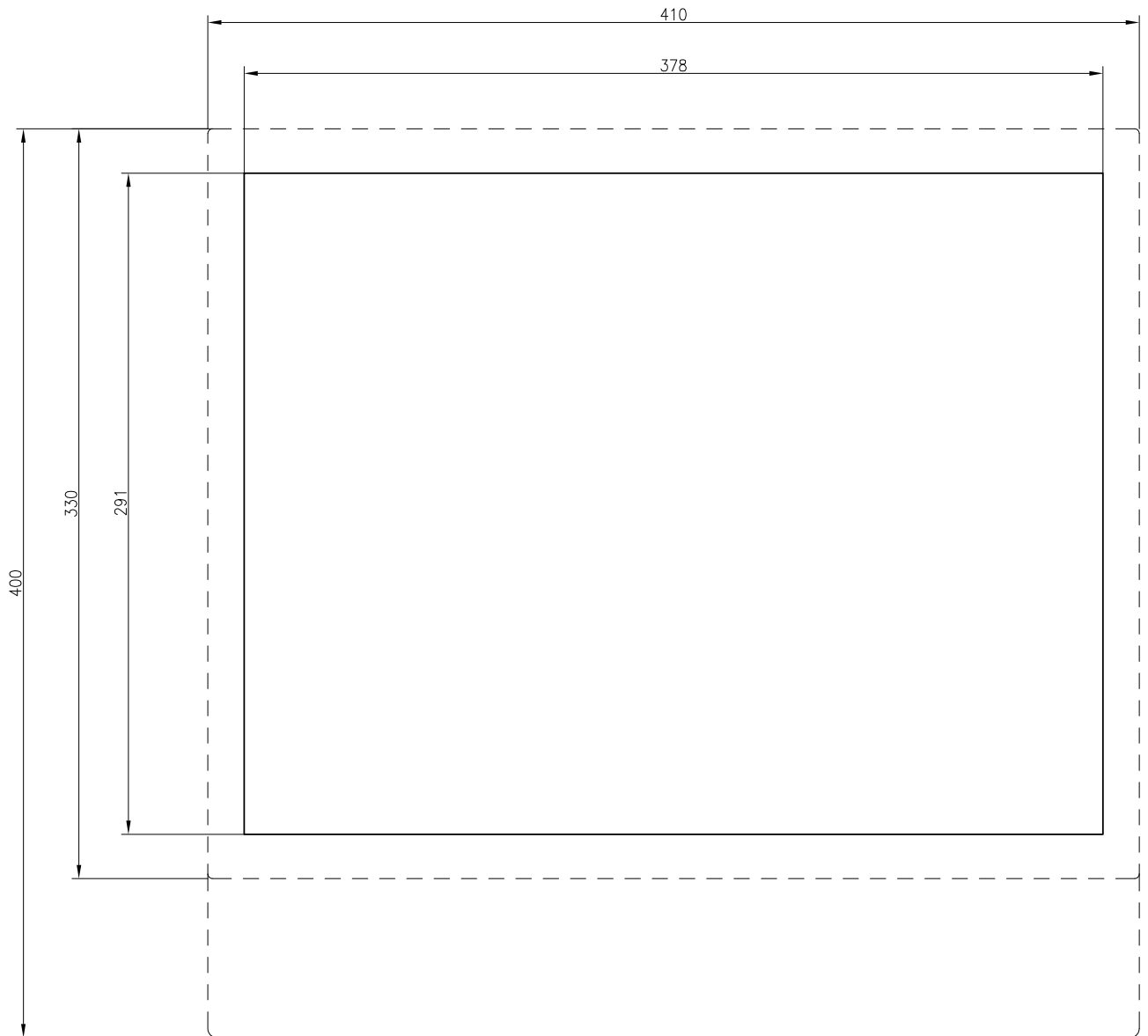

# Operator Panels and Industrial PC

## FS153i Operator Panels with Integrated iPC Ordering Codes

### Operator Panel FS153i Available Versions

The FS153i can be provided in the following versions:

- 2 different user interfaces (function keys FK, function keys with QWERTY keyboard FQ; touch screen optional)
- 2 different processors performance level P1 and P2
- Dual CAN+NVRAM interface optional

FS153i Version	Ordering Code
FS153i-FK P2 HD RT	FXPC153NF2HNR10
FS153i-FQ P2 HD RT	FXPC153NQ2HNR10
FS153i-FK TS P2 HD RT	FXPC153RF2HNR10
FS153i-FQ TS P2 HD RT	FXPC153RQ2HNR10
FS153i-FK P2 HD RT CAN NVRAM	FXPC153NF2HDR10
FS153i-FQ P2 HD RT CAN NVRAM	FXPC153NQ2HDR10
FS153i-FK TS P2 HD RT CAN NVRAM	FXPC153RF2HDR10
FS153i-FQ TS P2 HD RT CAN NVRAM	FXPC153RQ2HDR10
FS153i-FK P1 CF RT	FXPC153NF1CNR00
FS153i-FQ P1 CF RT	FXPC153NQ1CNR00
FS153i-FK P1 CF RT CAN NVRAM	FXPC153NF1CDR00
FS153i-FQ P1 CF RT CAN NVRAM	FXPC153NQ1CDR00

	FXPC	15	3	R	F	2	H	D	R	1	0
<b>Display Unit</b>											
- LCD 15"		15									
<b>Panel/Mechanical Variant</b>											
- Third generation			3								
<b>Display Sensor</b>											
- Touch screen resistive				R							
- No touch sensor				N							
<b>Keyboard Type</b>											
- 22 Function keys					F						
- 22 Function keys + Qwerty keyboard					Q						
<b>IPC Mother Board, Processor</b>											
- Performance level P1						1					
- Performance level P2						2					
<b>Mass Memory Type</b>											
- Compact flash <sup>1</sup>							C				
- HD (hard disk) <sup>2</sup>							H				
<b>Option Board</b>											
- No fieldbus								N			
- CAN + NVRAM								D			
<b>Flexium RTS</b>											
- Real time									R		
<b>Operating System</b>											
- Windows 8 Kernel										1	
<b>Spare Number</b>											0

<sup>1</sup> For performance level P1 only

<sup>2</sup> For performance level P2 only

# Operator Panels and Industrial PC

## FS192L, FS153 and FS122 Operator Panels

### FS192L, FS153 and FS122 Operator Panels (without Integrated iPC)

NUM has developed passive control panels for Flexium that are designed for use with an external PC or NUM Industrial Box PC P1/P2.

Three different passive panel sizes are available: 12" (FS122), 15" (FS153) units and 19" (FS192L).

The passive panels FS122 are available with and without touch screen. Both versions have got 22 functional keys.

The passive panels FS153-FK (keyboard option F) and FS153-FQ (keyboard option Q) have the same appearance and dimensions as NUM's FS153i panels, but do not have an integrated PC.

The passive panel FS192L is a landscape oriented projective, capacitive touch panel. The touch sensor supports dual-touch gestures.

The display quality makes the panels very legible, even in poorly-lit environments. Compact and very rugged, the panels are sealed (IP65) and suitable for use in severe industrial environments.

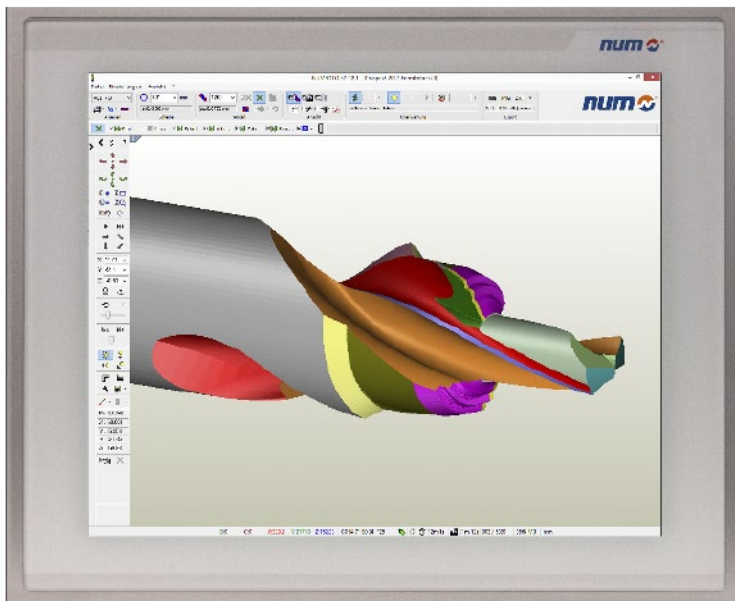

FS192L

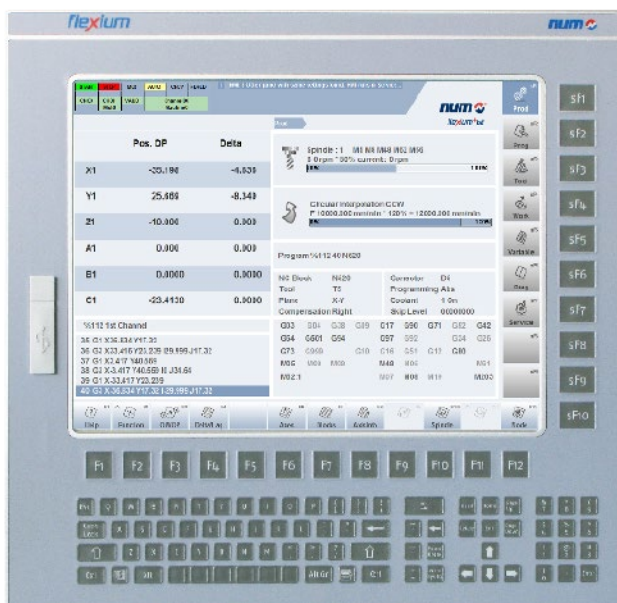

FS153-FQ

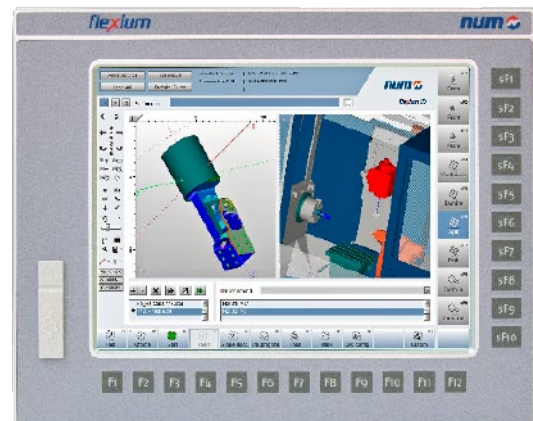

FS122

## FS192L Operator Panel

### FS192L Operator Panel

With the latest 19-inch landscape oriented, projected capacitive touch screen system, NUM has set a new standard for operating panels in the machine tool industry.

The FS192L operator panel provides a durable, modern front end for machine control. It has an IP65 degree of protection at the front, and IP20 at the rear. High-quality 4 mm hardened safety glass protects the front, without introducing any disturbing reflections.

A narrow brushed aluminum frame with rounded edges provides complete side protection for the glass and multi-touch sensor.

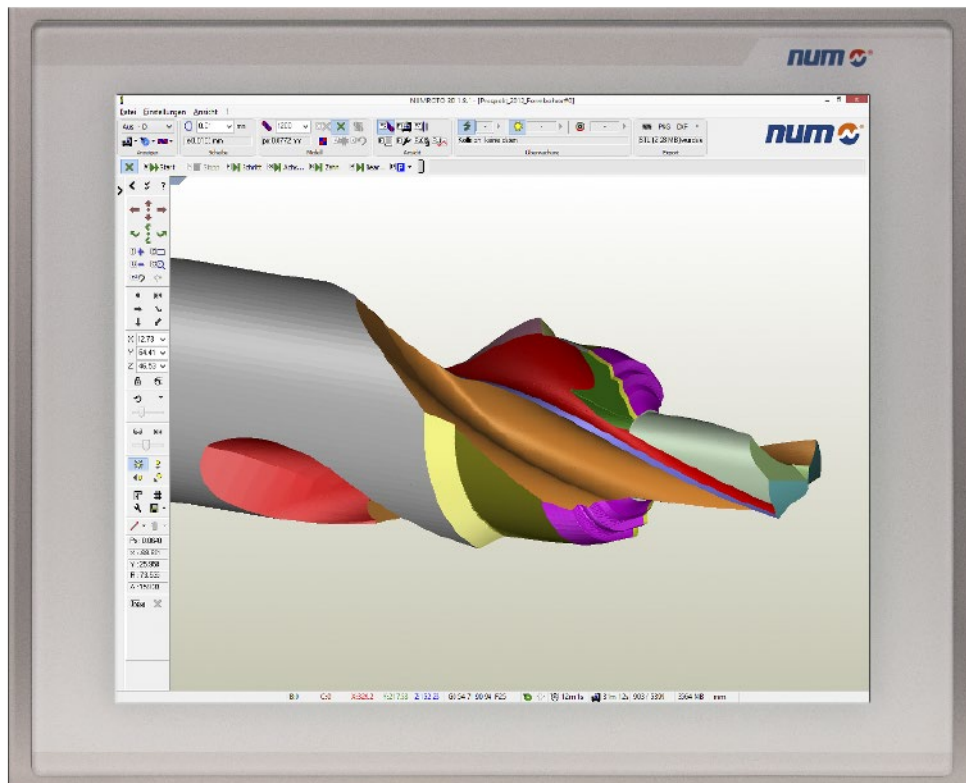

# Operator Panels and Industrial PC

## FS192L Operator Panel Technical Characteristics

### FS192L (without Integrated iPC) Technical Characteristics

FXPC192LCNNNNN00		
<b>Screen</b>	User interface options	Projected capacitive touch screen with hardened glass protection
	Technology	19" TFT LCD (16.9 million colours)
	Resolution	1280 x 1024 from 60Hz to 75Hz (horizontal/landscape orientation)
	Size	379 x 304 mm
	Backlight	Contr. 400:1 (Typ)
<b>Main PC Features</b>	CPU	External PC required
	RAM	
	Mass storage	
	Operating system	
	Graphic card	
<b>Communication Interfaces</b>	USB front (1x)	V2.0 - 1.5/12/480 MBit/s, USB Type A
	USB rear (x3)	V2.0 - 1.5/12/480 MBit/s, 2 USB Type A + 1 USB Type B
	DVI interface	1
<b>Power Supply</b>	Rated voltage	24 VDC SELV, safety extra low voltage. Protection class III.
	Voltage range	24 VDC 20.4...28.8 VDC rms / rated for 4A continuous load
	Protection against reverse polarity	Yes
	Protection against over voltage	Yes
	Potential isolation	No. (The 0V-pin of the PS is connected to the digital GND)
	Power consumption	ca. 50 W / As point of reference, the 24V-power supply should be rated for 4A continuous load.
<b>Ambient Conditions</b>	Climatic conditions operation	5..45 °C with horizontal mounting. 10...90 % rel. air humidity, non-condensing.
		The measuring point is defined 5cm over the top of the PC case in the middle of the vent holes. It is recommended to ensure enough air circulation.
	Climatic storage conditions	-20...60 °C, 10...90 % rel. air humidity, non-condensing
Climatic conditions, transport	Class 2K3 EN50178 (reduced) -20...60 °C, 10...90 % rel. Air humidity, non-condensing.	
<b>EMC</b>	EMC immunity	Industry EN 61000-6-2
	EMC emission	Residential area EN 61000-6-3
<b>Degree of Protection</b>	Front	IP 65
	Rear	IP 20
<b>Weight</b>		8.5 kg
<b>Dimensions</b>	W x H x D	Please refer to the following pages.
<b>Noise</b>		<70dB

# Operator Panels and Industrial PC

## FS192L Operator Panel Outlines

### Outlines FS192L (without Integrated iPC)

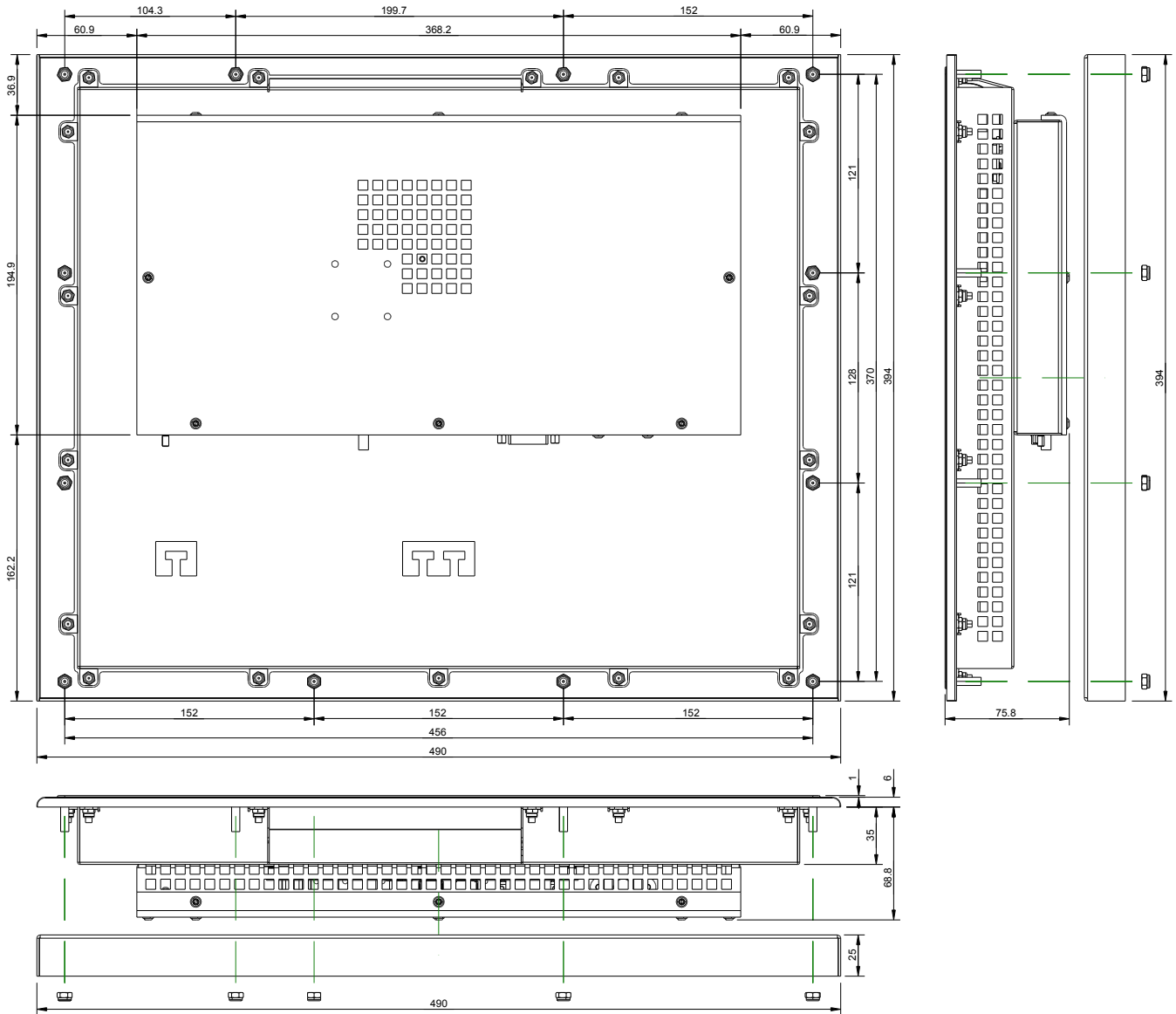

3

# Operator Panels and Industrial PC

## FS192L Operator Panel Outlines

### FS192L (without Integrated iPC) Cut-Out and Hole Patterns

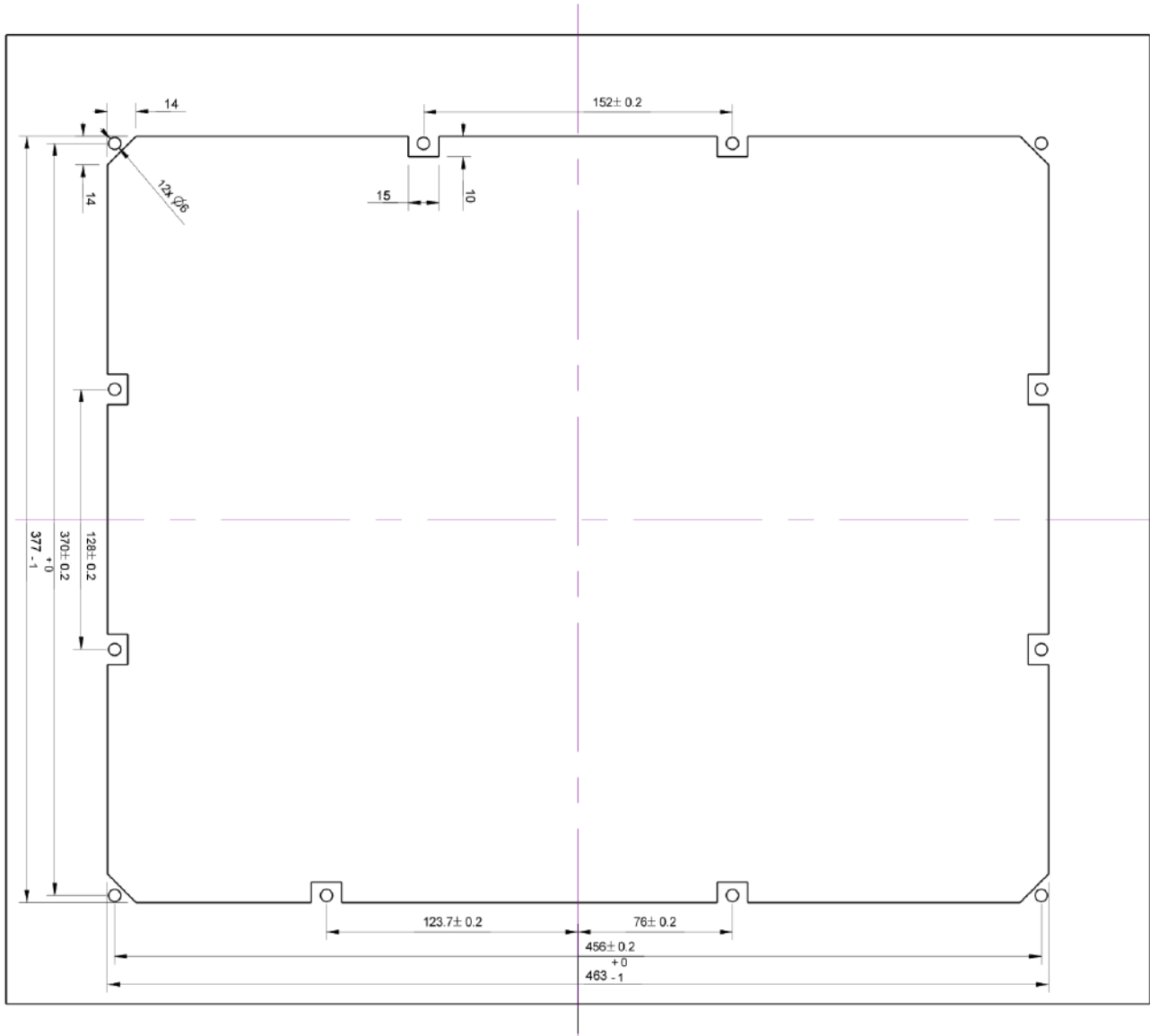

# Operator Panels and Industrial PC

## FS192L Operator Panel Outlines

### FS192L (without Integrated iPC) Cut Out when using Back Side Mounting Plate

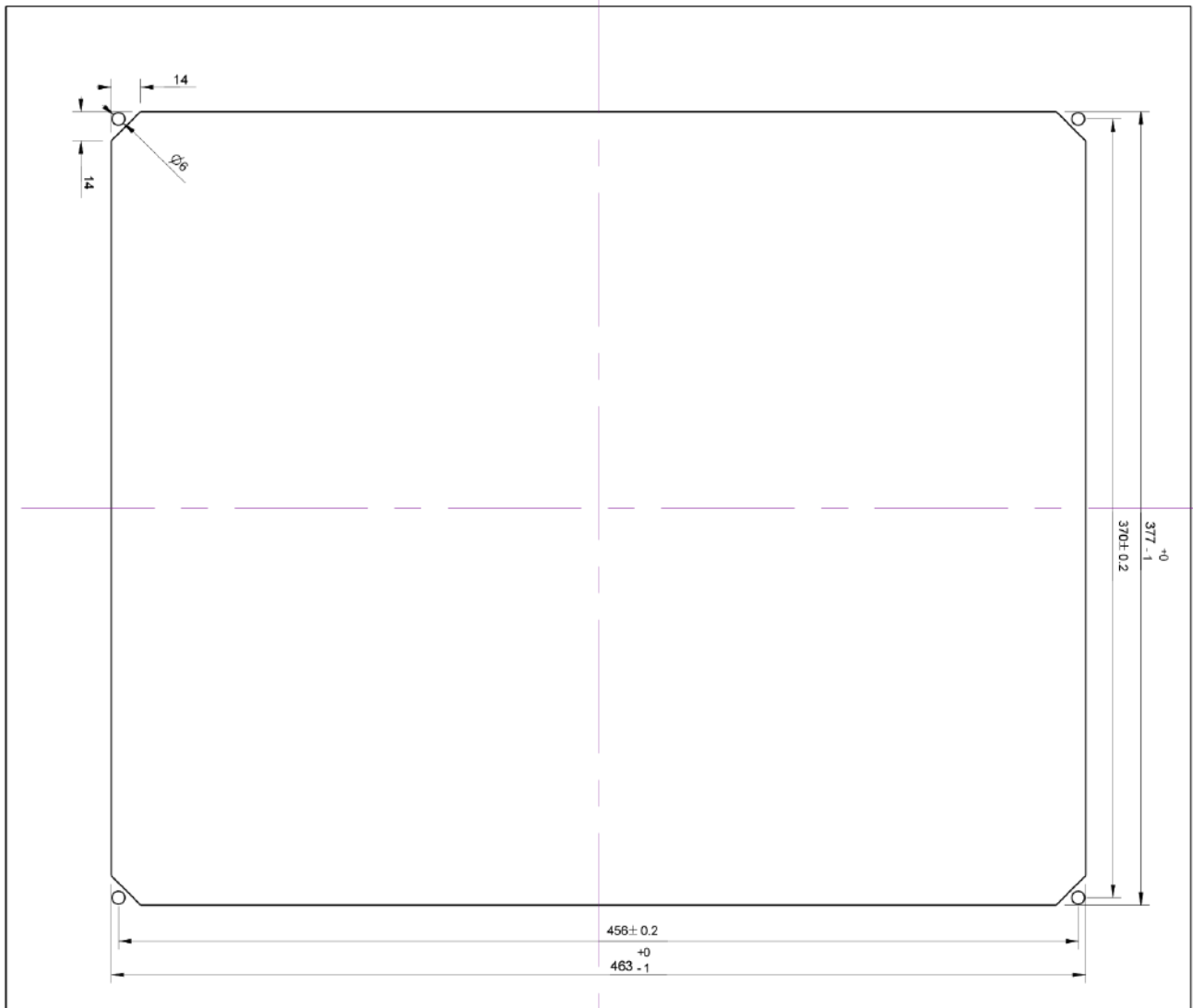

3

Cut-out in case of using back side mounting plate.

# Operator Panels and Industrial PC

## FS192L Operator Panel Ordering Code

### FS192L Ordering Code

The FS192L panels are recommended with NUM Industrial BoxPC P1/P2.

FS192L Version	Ordering Code
FS192L-TS	FXPC19LCNNNNN00

	FXPC	19	L	C	N	N	N	N	N	N	0	0
<b>Display Unit</b>												
- LCD 19"		19										
<b>Panel/Mechanical Variant</b>												
- Landscape			L									
<b>Display Sensor</b>												
- Touch screen (proj.) capacitive				C								
<b>Keyboard Type</b>												
- No keyboard, no function keys						N						
<b>IPC Mother Board, Processor</b>												
- No IPC, just operator panel							N					
<b>Mass Memory Type</b>												
- No IPC, just operator panel								N				
<b>Option Board</b>												
- No fieldbus, just operator panel									N			
<b>Flexium RTS</b>												
- No RTS, just operator panel										N		
<b>Operating System</b>												
- No IPC, just operator panel											0	
<b>Spare Number</b>												0

# Operator Panels and Industrial PC

## FS153 Operator Panels User Interface Options

### User Interface Options



Panel with 22 Function Keys

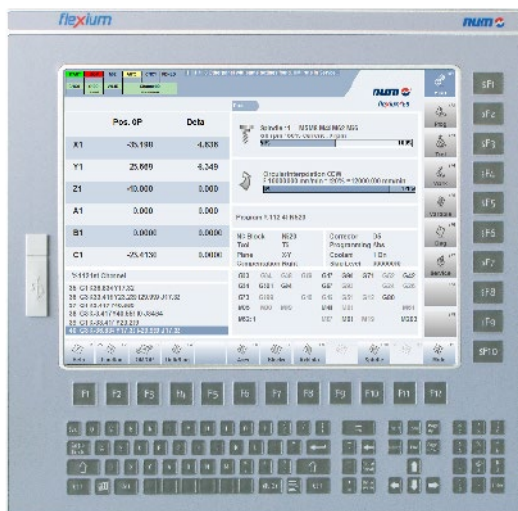

Panel with 22 Function Keys and QWERTY-Keyboard

3

# Operator Panels and Industrial PC

## FS153 Operator Panels Technical Characteristics

### FS153 (without Integrated PC) Technical Characteristics

		<b>FXPC153xFNNNN00</b> <b>FXPC153NQNNNN00</b>
Screen	User interface options	Operator panel without integrated PC: - 22 Function Keys - 22 Function Keys and Qwerty Keyboard - Touch Screen (resistive)
	Technology	15" TFT LCD (16.9 million colors)
	Resolution:	1024 x 768 from 60Hz to 75Hz
	Size	304 x 228 mm (12 x 9 inch)
	Backlight	LED, Contr. 700:1 (Typ)
Main PC Features	CPU	External PC required
	RAM	
	Mass storage	
	Operating system	
Communication Interfaces	USB front	1 x USB Type A
	USB rear	2 x USB Type A (only 1 x USB Type A in case of touch version) + 1 x USB type B
	DVI interface	1
	VGA interface	1
Power Supply	Rated voltage	24VDC (+15%/-15%) SELV.
	Protection against reverse polarity	Yes
	Protection against over voltage	Yes
	Potential insulation	no, the 0V pin is connected to the digital GND
	Power consumption	ca. 28 W
Environmental Conditions	Climatic conditions, operation	0..50°C , 70% relative air humidity, non-condensing
	Climatic conditions, storage	-20..60°C, 70% relative air humidity, non-condensing
	Climatic conditions, transport	-20..60°C, 90% rel. air humidity, non-condensing.
Degree of Protection	Front	IP 65
	Rear	IP 20
	Pollution degree	2
Weight		ca. 5.3 kg Function Key version ca. 5.7 kg Full Qwerty version
Dimensions	W x H x D	410 x 330 (400) x 52.3 mm
Cooling Type		Fanless

# Operator Panels and Industrial PC

## FS153 Operator Panels Outlines

### Outlines FS153 (without Integrated PC)

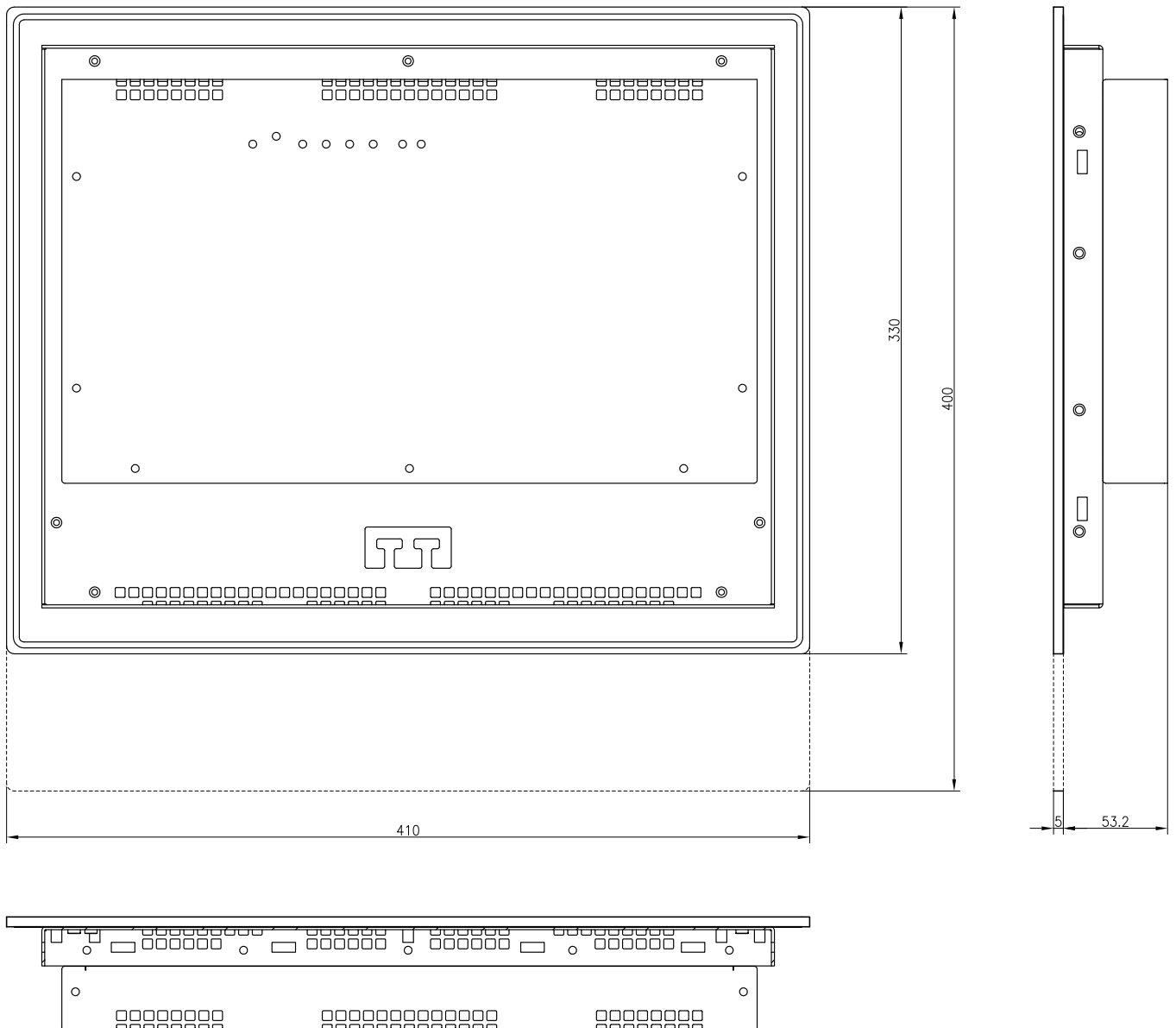

3

# Operator Panels and Industrial PC

FS153 Operator Panels  
Outlines



## Operator Panel FS153 Cut-Out and Hole Pattern

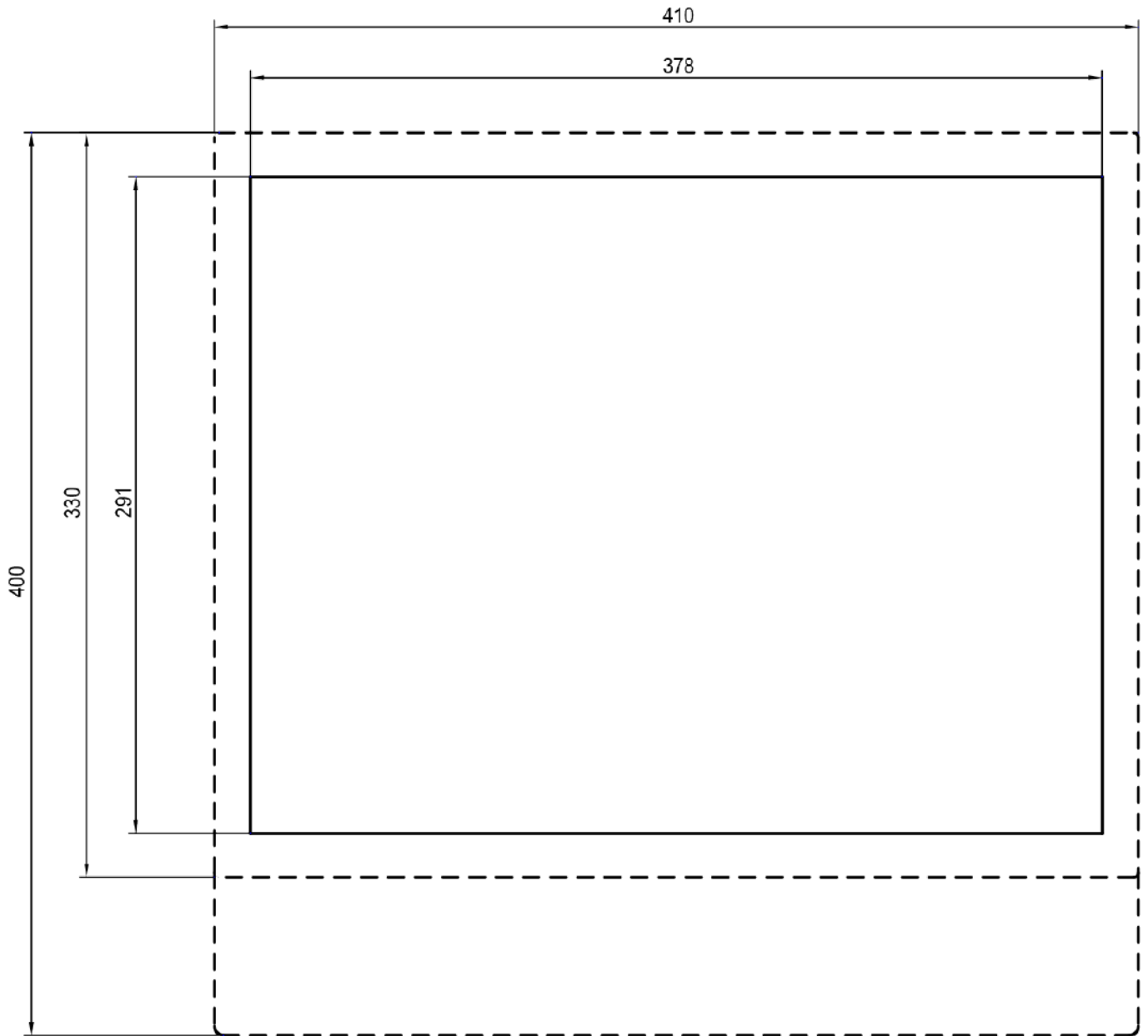

# Operator Panels and Industrial PC

## FS153 Operator Panels Ordering Codes

### FS153 Ordering Codes

The FS153 panels can be provided in two different versions and with two different fronts (function keys and function keys with QWERTY keyboard):

- FS153-FK: 15" Screen for PC-Panel with function keys
- FS153-FQ: 15" Screen for PC-Panel with function keys and QWERTY keyboard

FS153 Version	Ordering Codes
FS153-FK	FXPC153NFNNNN00
FS153-FK TS	FXPC153RFNNNN00
FS153-FQ	FXPC153NQNNNN00

	FXPC	15	3	R	F	N	N	N	N	0	0
<b>Display Unit</b>											
- LCD 15"		15									
<b>Panel/Mechanical Variant</b>											
- Third generation <sup>1</sup>			3								
<b>Display Sensor</b>											
- Touch screen resistive				R							
- No touch Sensor				N							
<b>Keyboard Type</b>											
- 22 Function keys					F						
- 22 Function keys + Qwerty keyboard					Q						
<b>IPC Mother Board, Processor</b>											
- No IPC, just operator panel						N					
<b>Mass Memory Type</b>											
- No IPC, just operator panel							N				
<b>Option Board</b>											
- No fieldbus, just operator panel								N			
<b>Flexium RTS</b>											
- No RTS, just operator panel									N		
<b>Operating System</b>											
- No IPC, just operator panel										0	
<b>Spare Number</b>											0

3

# Operator Panels and Industrial PC

## FS122 Operator Panels User Interface Options

### User Interface Options



Panel with 22 Function Keys

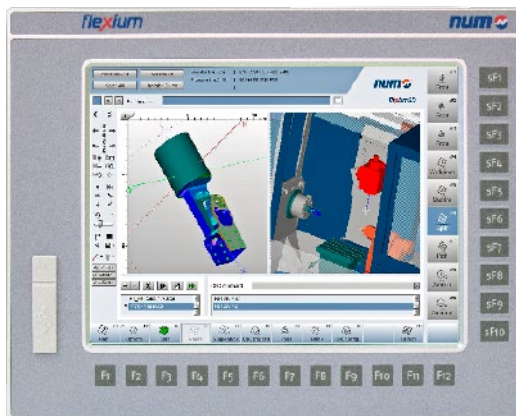

Panel with 22 Function Keys and  
Resistive Touch Screen

# Operator Panels and Industrial PC

## FS122 Operator Panels Technical Characteristics

### FS122 Technical Characteristics

FXPC122xFNNNN00		
<b>Screen</b>	User interface	22 Function Keys Resistive touch screen available as option
	Technology	12.1" LED
	Resolution	1024 x 768 on 60 Hz till 75 Hz
	Size	Diagonal 307 mm
	Contrast	Contr. 700:1
	Brightness	600cd/m <sup>2</sup>
<b>Main PC Features</b>	CPU	External PC required
	RAM	
	Mass storage	
	Operating system	
	Graphic card	
<b>Communication Interfaces</b>	USB front (x1)	V2.0 - 1.5/12/480 MBit/s USB Type A
	USB rear (x3)	V2.0 - 1.5/12/480 MBit/s 2 USB Type A + 1 USB type B (1)
	DVI interface	1
	VGA interface	1
<b>Power Supply</b>	Rated voltage	24 VDC SELV, safety extra low voltage. Protection class III
	Voltage range	24 VDC 20.4...28.8 VDC rms / rated
	Protection against reverse polarity	Yes
	Protection against over voltage	Yes
	Potential isolation	No. (The 0V-pin of the PS is connected to the digital GND)
	Power consumption	ca. 25 W. As point of reference, the 24V-power supply should be rated for 4A continuous load
<b>Ambient Conditions</b>	Climatic conditions operation	0..50 °C , 10...90 % relative air humidity, non-condensing
	Climatic storage conditions	-20...60 °C, 10...90 % relative air humidity, non-condensing
	Climatic conditions, transport	Class 2K3 EN50178 (reduced -20...60°C, 10...90% relative air humidity, non-condensing)
<b>EMC</b>	EMC immunity	Industry EN 61000-6-2
	EMC emission	Residential area EN 61000-6-3
<b>Degree of Protection</b>	Front	IP 65
	Rear	IP 20
<b>Weight</b>		3.45 kg
<b>Dimensions</b>	W x H x D	347 x 276 x 63 mm
	Cut out	331 x 260 mm (+0/-1mm)

3

# Operator Panels and Industrial PC

## FS122 Operator Panels Outlines

### FS122 Outlines

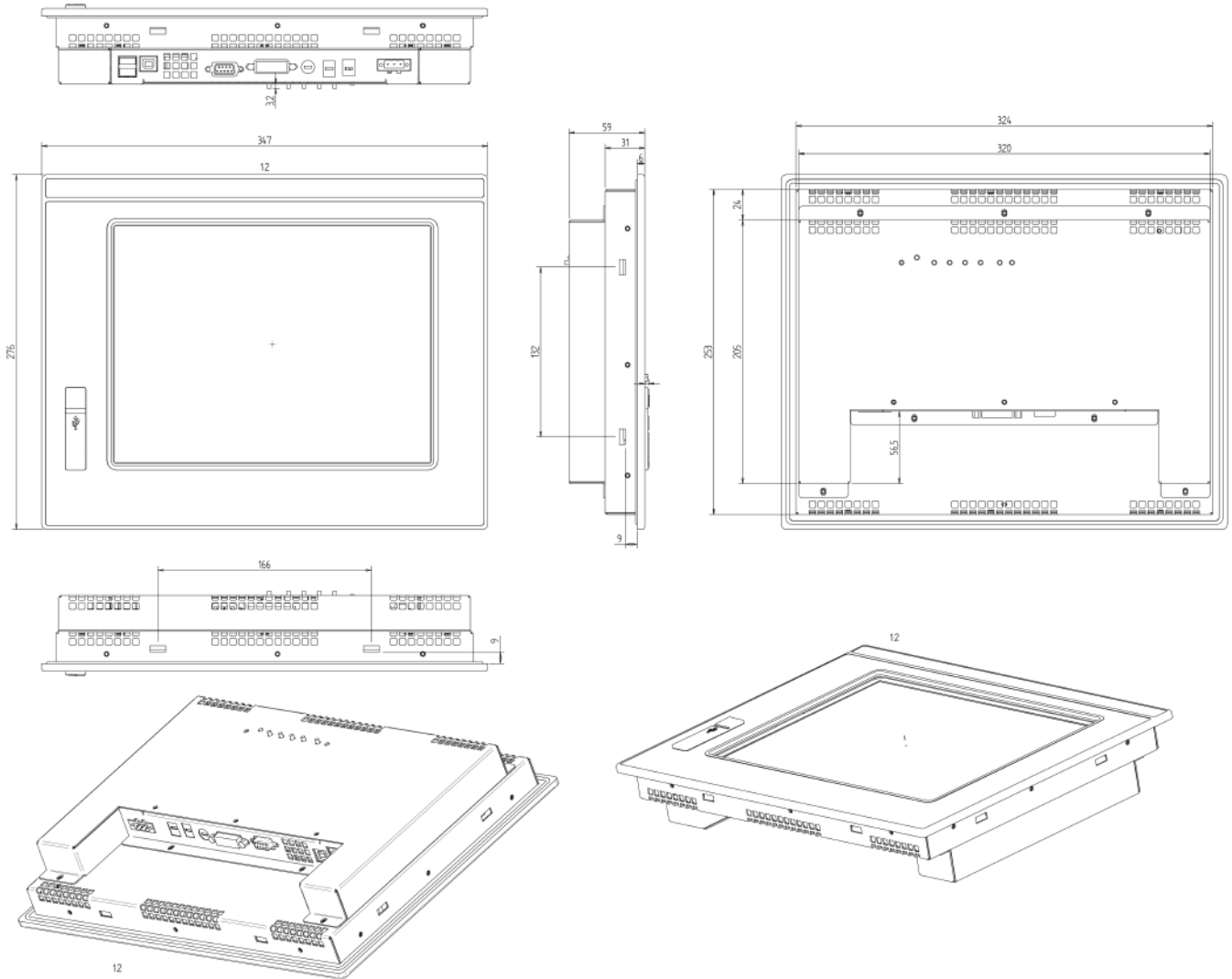

### Cut-Out and Pattern

For FS122 a simple rectangle cut out is needed (no holes); the cut out has the following dimensions: 331 x 260 mm (+0/-1mm).

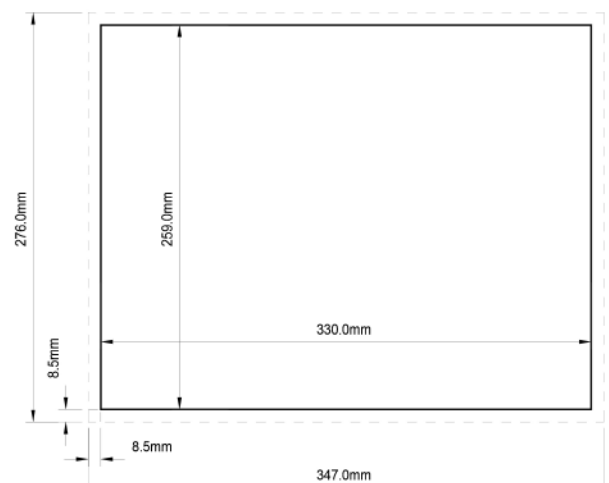

# Operator Panels and Industrial PC

## FS122 Operator Panels Ordering Codes

### FS122 Ordering Codes

FS122 Version	Ordering Codes
FS122-FK-TS	FXPC122RFN>NNN00
FS122-FK	FXPC122NFN>NNN00

	FXPC	12	2	R	F	N	N	N	N	0	0
<b>Display Unit</b>											
- LCD 12"		12									
<b>Panel/Mechanical Variant</b>											
- Second generation			2								
<b>Display Sensor</b>											
- Touch screen resistive				R							
- No touch Sensor				N							
<b>Keyboard Type</b>											
- 22 Function keys					F						
<b>IPC Mother Board, Processor</b>											
- No IPC, just operator panel						N					
<b>Mass Memory Type</b>											
- No IPC, just operator panel							N				
<b>Option Board</b>											
- No fieldbus, just operator panel								N			
<b>Flexium RTS</b>											
- No RTS, just operator panel									N		
<b>Operating System</b>											
- No IPC, just operator panel										0	
<b>Spare Number</b>											0

3

## MP05 Machine Panel

### MP05 Machine Panel

To accompany the new FS192i touch panel, NUM has launched the MP05 machine panel. This uses the same 4 mm hardened safety glass as the FS192i and has the same IP65 protection level at the front. A solid aluminum frame with back plate ensures correct stiffness.

MP05 complements the FS192i's virtual machine panel by adding physical interfaces for functions that need tactile feedback.

The combination provides OEMs with a powerful competitive advantage.

Components of the machine panel:

- E-Stop button
- 4 luminous push buttons (e.g. NC-Start, NC-Stop, NC-Reset, machine ON, customizable)
- USB 2.0 interface
- 2 step key switch
- 2 Overrides (Feed rate and Spindle, adjustable via PLC)
- Handwheel (100 Impulses/rev.)



# Operator Panels and Industrial PC

## MP05 Machine Panel Outlines

### MP05 Machine Panel Outlines

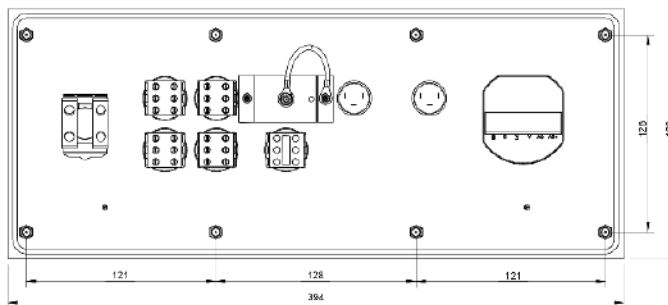
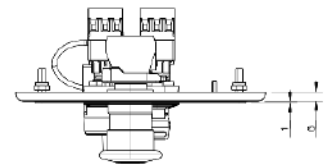
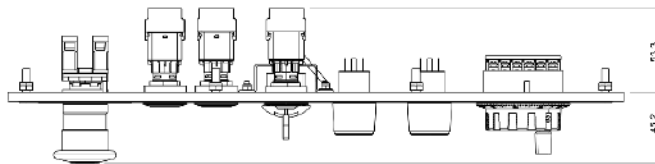
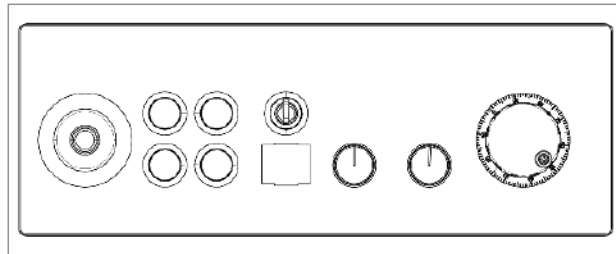

### Cut-Out and Hole Pattern

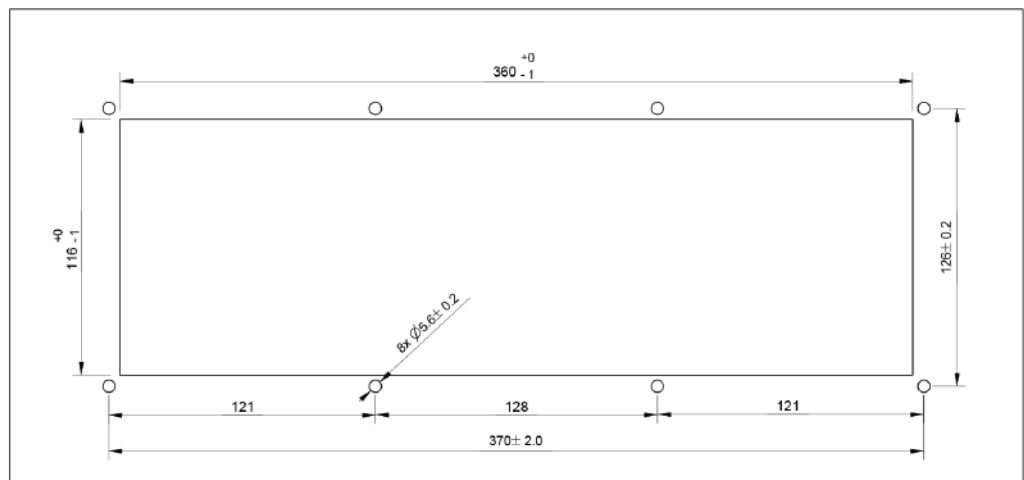

3

# Operator Panels and Industrial PC

MP05 Machine Panel  
Ordering Code



## MP05 Machine Panel

Machine Panel MP05 available versions:

MP05 with Handwheel	Ordering Code
Machine Panel MP05-H	FXHE558520

## MP04 Machine Panel

### MP04 Machine Panel

This panel is used for manually controlling movement, production initiation and intervention during machining.

Two versions are available:

- Machine Panel MP04–W, without handwheel (reference FXHE558110)
- Machine Panel MP04–H, with handwheel (reference FXHE558120)

The panels provide:

- 55 configurable keys with LEDs
- 2 potentiometers for spindle speed and feed rate override
- 1 handwheel (FXHE 558 120 only)
- 1 emergency stop button
- 1 three-position key switch
- 3 controls: Cycle start, Cycle stop and Reset
- 5 keys for additional functions with LEDs

The MP04 has to be connected via CAN.

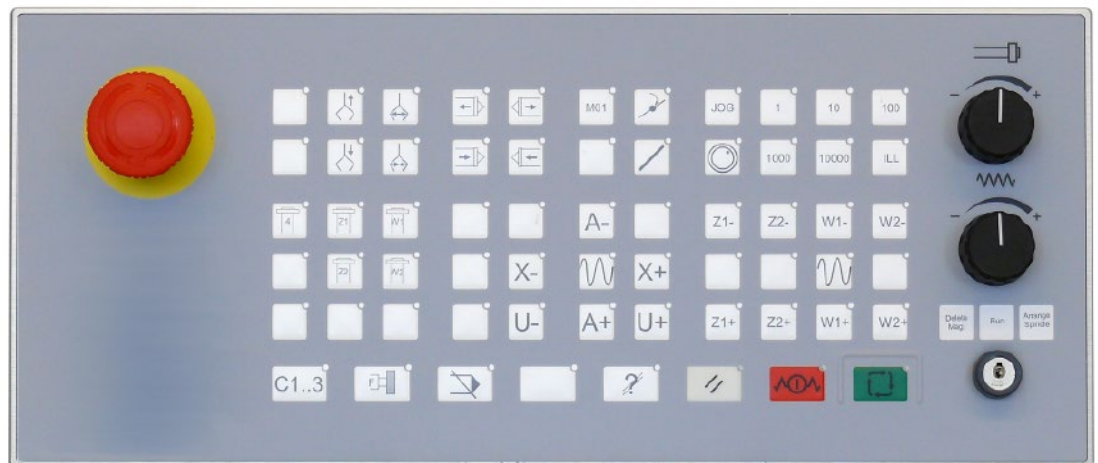

# Operator Panels and Industrial PC

## MP04 Machine Panel Options

### MP04 Machine Panel MP04-H (with Handwheel)

- CAN interface
- 63 programmable function keys
- Same width as FS153i
- Handwheel

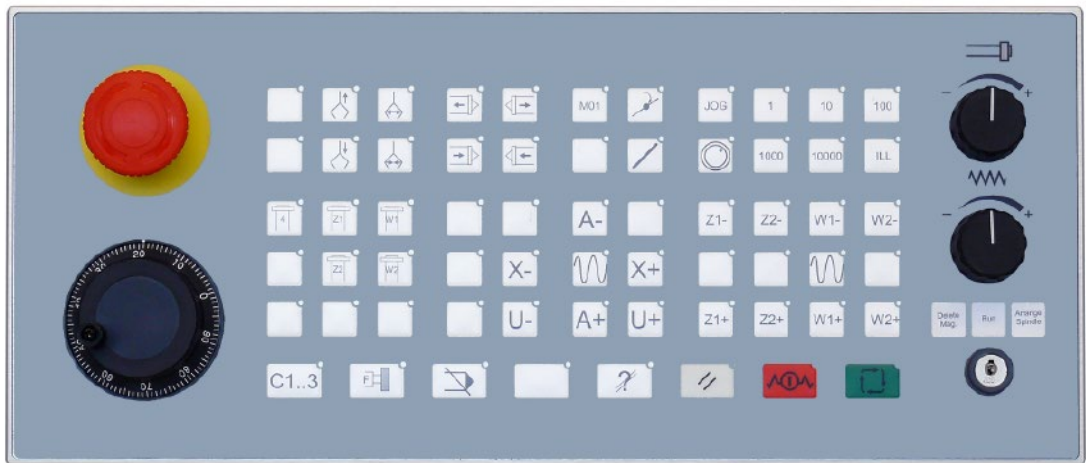

### MP04 Machine Panel MP04-W (without Handwheel)

- CAN interface
- 63 programmable function keys
- Same width as FS153i

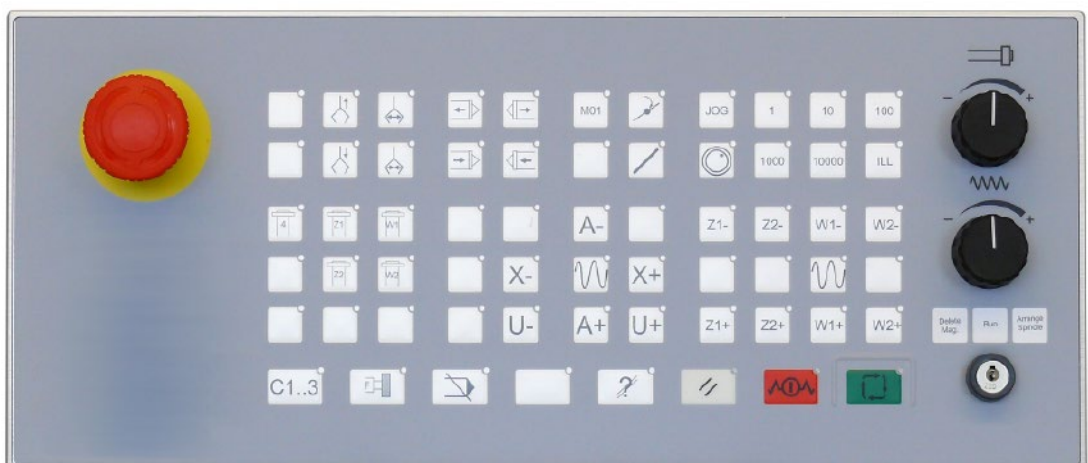

# Operator Panels and Industrial PC

## MP04 Machine Panel Technical Characteristics

### MP04 Machine Panels Technical Characteristics

		FXHE558110	FXHE558120
MP04 Panel	User interface	63 freely programmable keys	63 freely programmable keys
	Handwheel	Not present	Yes (100 Pulses per revolution)
	CAN interface	Yes (9 Pins Sub-D)	
On Board Sensor	Key switch	3 positions	
	Potentiometer	For spindle speed override (10kOhm potentiometers, 2.5 VDC, 10Bit resolution)	
	Potentiometer	For feed rate override (10kOhm potentiometers, 2.5 VDC, 10Bit resolution)	
	1 input for handwheel	For a 5 VDC handwheel with A & B push-pull signal, max. 100mA	
	Emergency stop	1	1
Press Buttons	55 softkeys with LED	Free configurable	
	3 controls with LED	Cycle start, cycle stop and reset	
	5 softkeys with LED	Free configurable for additional functions with LED	
Digital Inputs	12 digital inputs	Organisation: 3 groups of semiconductor type terminals	
	Operating voltage	24V -15% / +10% (20.4 -26.4V)	
	Logic 0	0 to 5 VDC	
	Logic 1	6 to 26.4 VDC	
	In current	4mA typical at 24 VDC	
	Reaction time	8ms typical (debounced)	
Digital Outputs	12 digital outputs	Organisation: 3 groups of semiconductor type terminals	
	Operating voltage	24V -15% / +10% (20.4 -26.4V)	
	Rated current	100 mA maximum per output	
	Outputs simultaneously active	100%	
	Protection	Short-circuit and permanent overloads (trip device)	
Power Supply	Rated voltage	24 VDC SELV, safety extra low voltage. Protection class III	
	Voltage range	24 VDC 20.4...28.8 VDC rms	
	Protection against reverse polarity	Yes	
	Protection against over voltage	Yes	
	Fuse protection	Yes, self resettable	
	Potential isolation	No. (The 0V-pin of the PS is connected to the digital GND)	
	Power consumption	ca. 15 W (max)	
Ambient Conditions	Climatic conditions, operation	0..45°C with mounting, 10...90% rel. air humidity, non-condensing.	
	Climatic conditions, storage	-20...60°C, 10...90% rel. air humidity, non-condensing	
	Climatic conditions, transport	Class 2K3 EN50178 (reduced) -20...60°C, 10...90% rel. Air humidity, non-condensing.	
EMC	EMC immunity	Industry EN 61000-6-2	
	EMC emission	Residential area EN 61000-6-3	
	Electrical safety	EN 60950 and EN 50178	
	Conformity	MP04-W and MP04-H meets the requirements specified by the EU Council Directives for harmonizing the regulations of EU member states relating to electromagnetic compatibility (89/336/EEC).	
Degree of Protection	Front	IP 65 (NEMA 12), EN 60068-2-68	
	Rear	IP 20	
Weight		ca. 1.2 kg	ca. 1.3 kg
Dimensions	W x H x D	410 x 330 x 65 mm	410 x 400 x 65 mm
	Cut-out	378 x 298 mm (+0/-1 mm) / Please refer to next pages.	

3

# Operator Panels and Industrial PC

## MP04 Machine Panel Outlines

### MP04-H and MP04-W Machine Panel Outlines

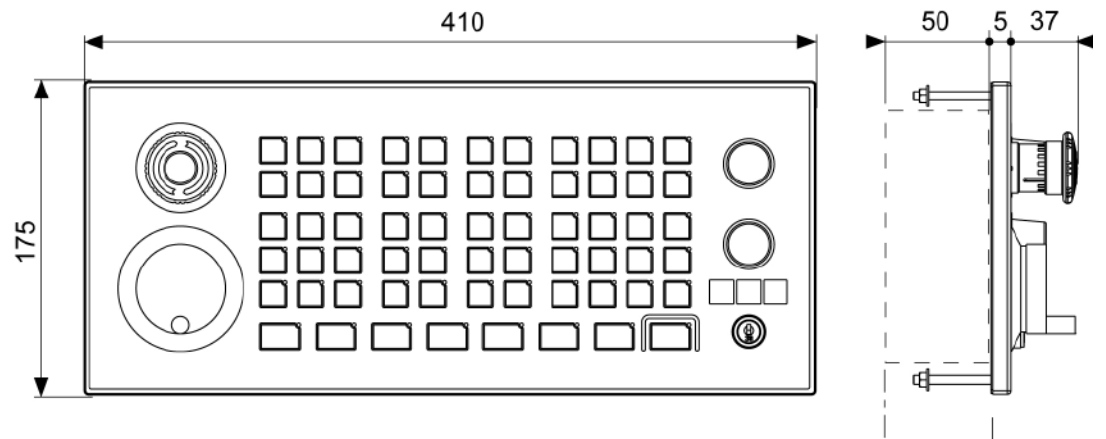

### Cut-Out and Hole Pattern

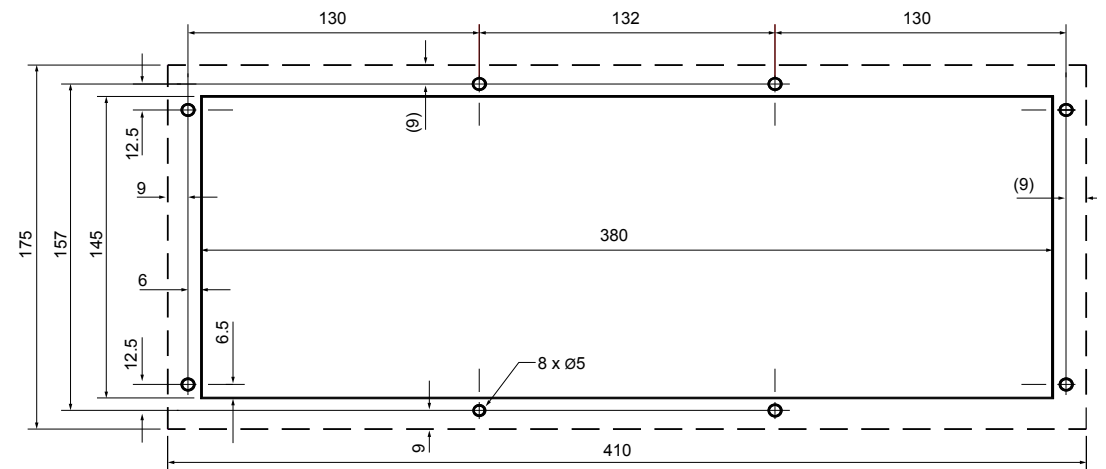

Tolerance of the cut-out: +0/-1mm

# Operator Panels and Industrial PC

## MP04 Machine Panel Ordering Codes

### MP04-H and MP04-W Machine Panel Ordering Codes

- Machine Panel MP04–W without handwheel
- Machine Panel MP04–H with handwheel

MP04 Version	Ordering Codes
Machine Panel MP04–W	FXHE558110
Machine Panel MP04–H	FXHE558120

3

# Operator Panels and Industrial PC

## Industrial Box PC

### NUM Industrial Box PC

NUM's Industrial Box PC can be used in two different ways:

- For very demanding applications that require a powerful workstation (e.g. for CAD/CAM), the PC1 version of the Industrial Box PC handles only the Flexium+ PLC.
- The P2 version of NUM's Industrial Box PC can be used with an FS153 passive panel to handle the Flexium HMI as well as the Flexium+ PLC.



Box PC P1

Box PC P2

# Operator Panels and Industrial PC

## Industrial Box PC

### NUM Industrial Box PC 1 (FXPC002NN1CxR00)

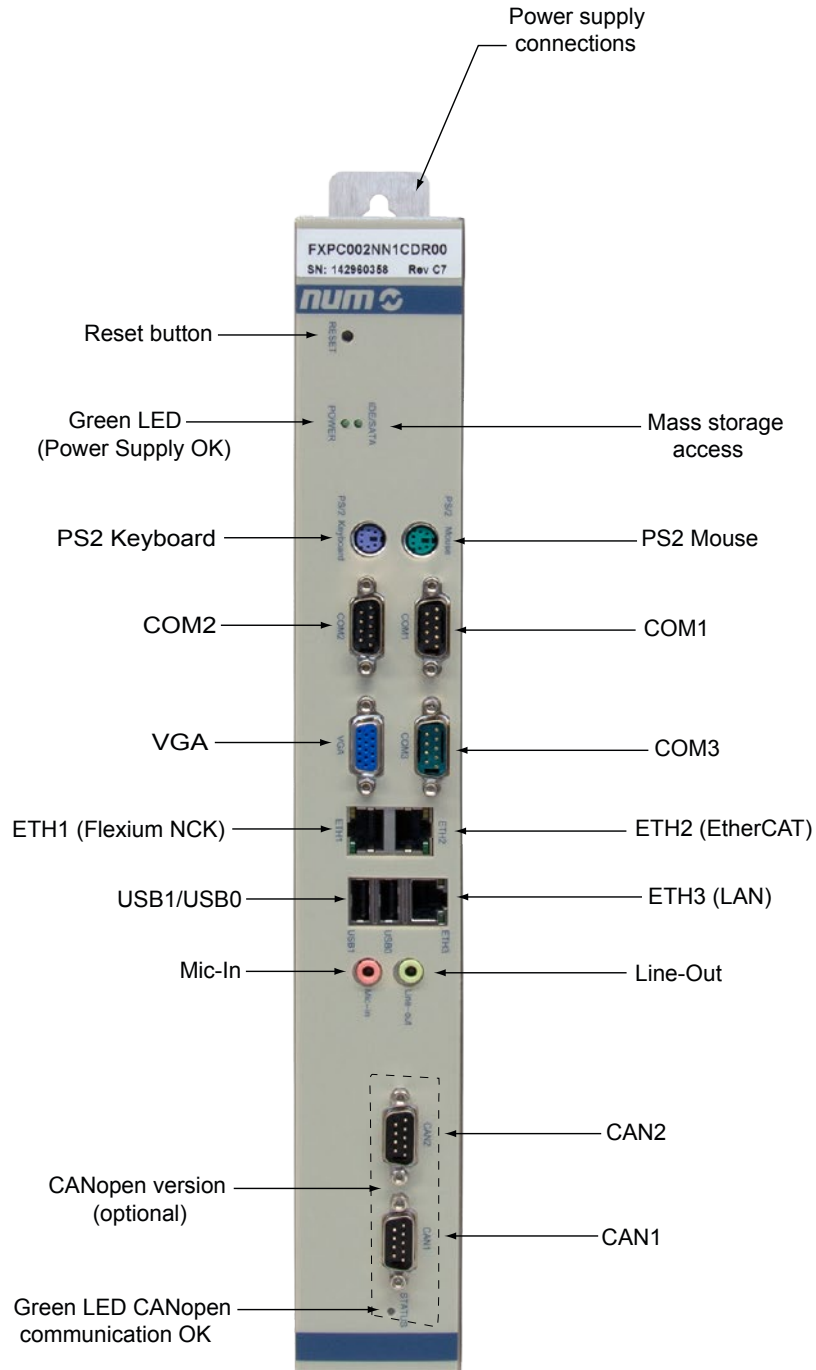

# Operator Panels and Industrial PC

## Industrial Box PC

### NUM Industrial Box PC 2 (FXPC002NN1HxR00)

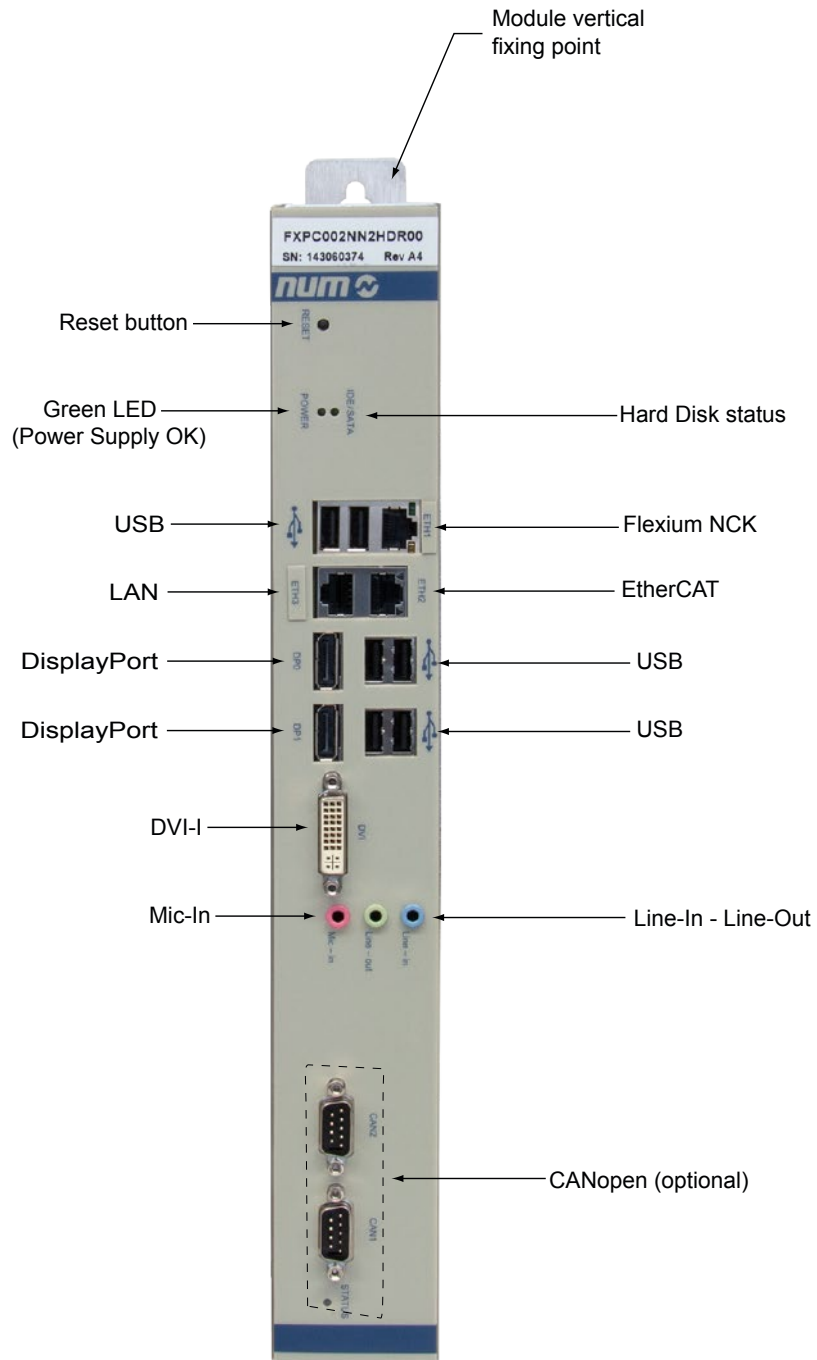

# Operator Panels and Industrial PC

## Industrial Box PC Technical Characteristics

### NUM Industrial Box PC Technical Characteristics

		FXPC002NN1CxR00 (PC P1)	FXPC002NN2Hxr10 (PC P2)
Main PC Features	CPU	Intel® Atom™ CPU D525 @ 1.80 GHz Dual Core	Intel® Core i5-2510E @ 2.50 GHz Dual Core
	RAM	2 GB	2 GB
	Mass storage	CF 8 GB	HD 250 GB
	Operating system	WES 2009	Win. Embedded 8.1 Industry Pro Win. XP Prof. for Embedded Systems
Communication Interfaces	Ethernet (ETH)	3x Gigabit LAN / RTE	3x Gigabit LAN / RTE
	CAN+NVRAM	2 - CAN1 / CAN2 (as option)	
	USB	2	6
	COM	3	0
	PS2	Yes. Keyboard / Mouse	0
	Mic-In / Line Out	Yes	
	VGA	1	0
	DVI interface	No	1
Power Supply	DisplayPort	No	2
	Rated voltage	24 VDC (+15%/-15%) / 1A	24 VDC (+15%/-15%) / 4A
	Protection fuse	Yes. Internal fuse 2A/250V	
	Power consumption	ca. 14 W	ca. 40 W
Ambient Conditions	Climatic conditions, operation	0..40°C, 70% rel. air humidity, non-condensing	
	Climatic conditions, storage	-40...80°C, 70% rel. air humidity, non-condensing	
	Environmental conditions, installation	Requires protection to at least IP54	
	Climatic conditions, transport	Class 2K3 EN50178 (reduced) -20...60°C, 10...90% rel. Air humidity, non-condensing.	
Degree of Protection	IP20		
Pollution Degree	2		
Cooling Type	Internal (with fan)		Internal (with fan)
Weight	ca. 2.4 kg		ca. 2.5 kg
Dimensions	W x H x D	50 x 355 (410) x 206 mm (Please refer to the next pages)	

3

# Operator Panels and Industrial PC

## Industrial Box PC Outlines

### NUM Industrial Box PC 1 Outlines (FXPC002NN1CxR00)

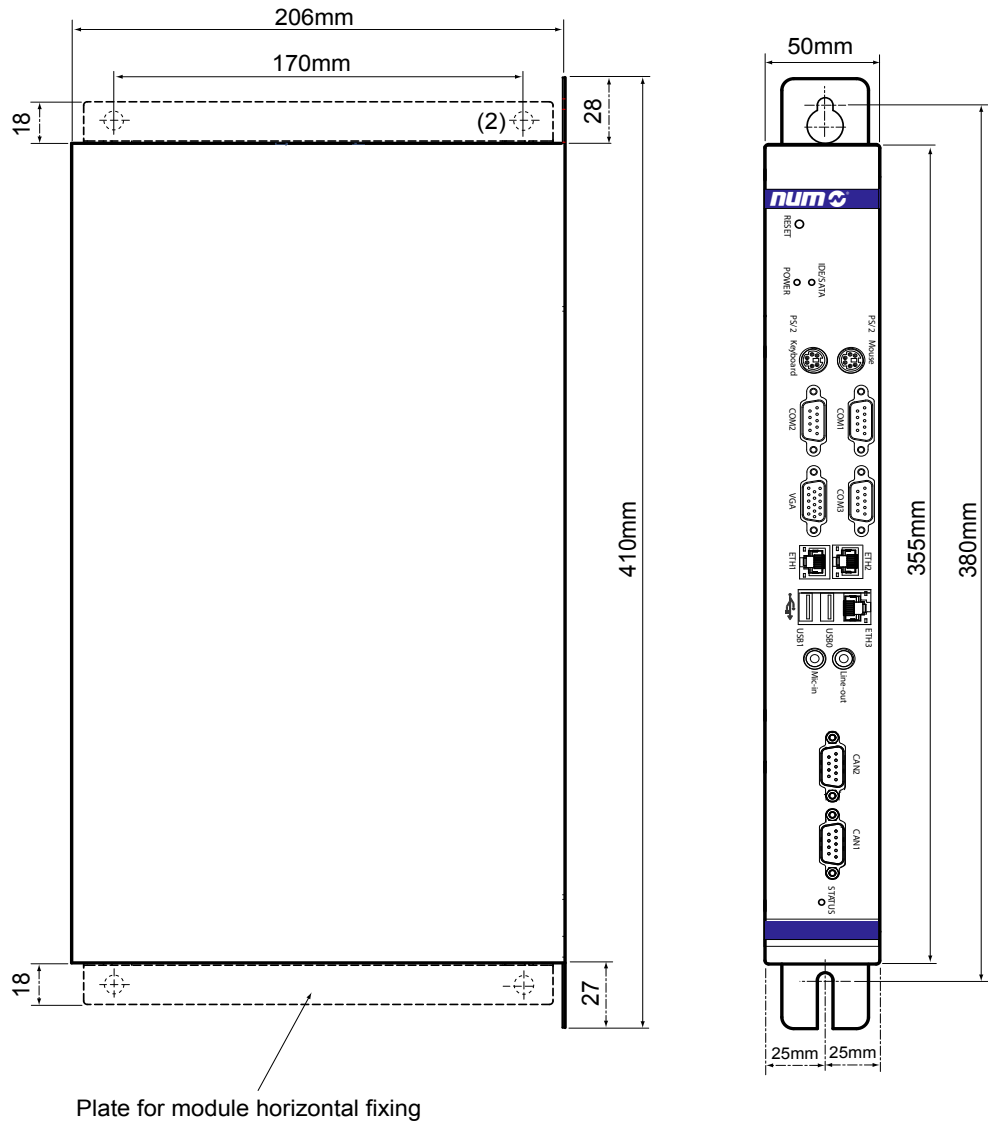

### Module horizontal fixing

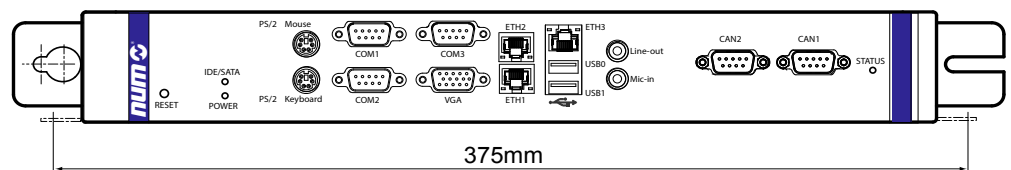

# Operator Panels and Industrial PC

## Industrial Box PC Outlines

### NUM Industrial Box PC 2 Outlines (FXPC002NN2HxR00)

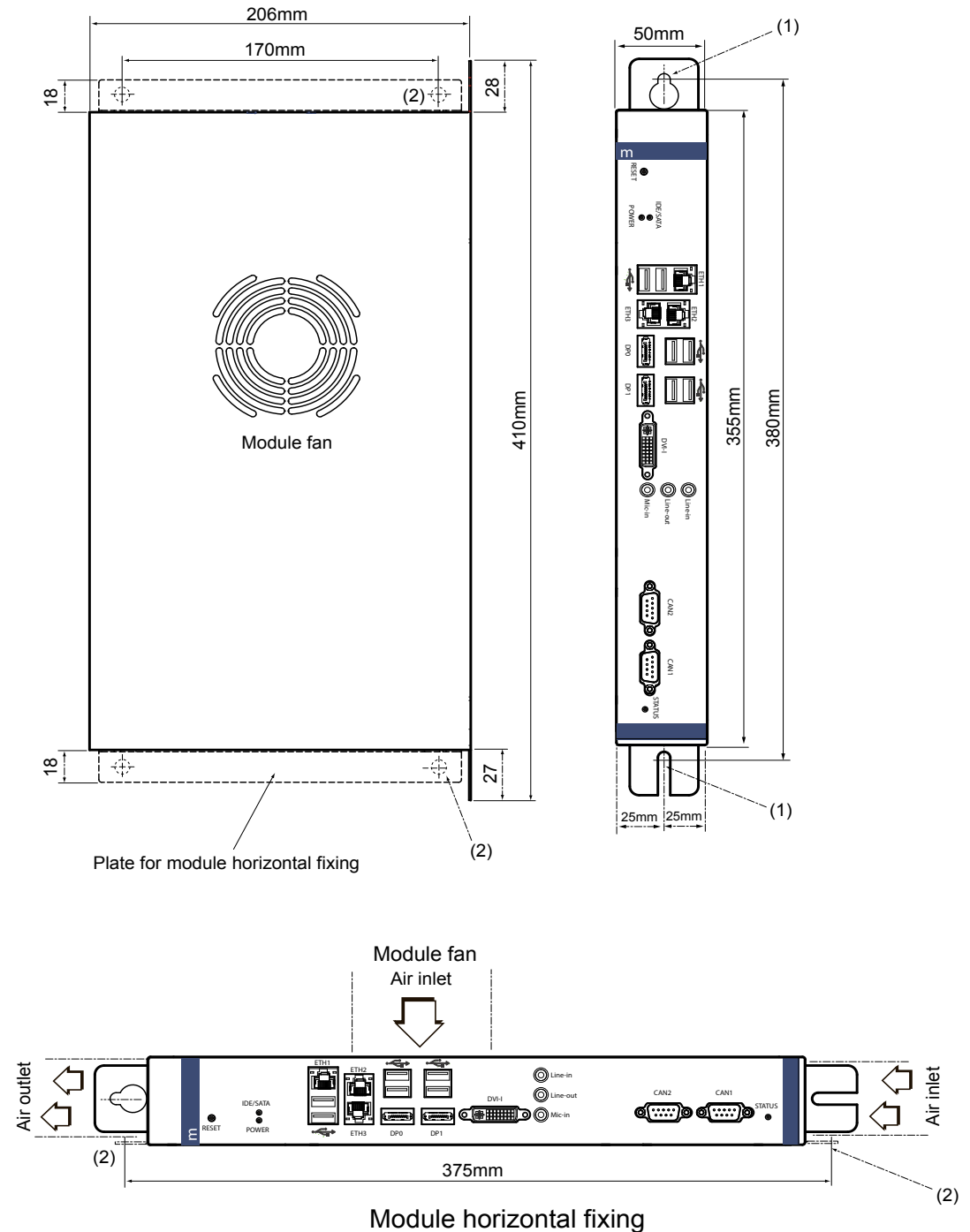

- (1) Provide 2 x M6 fixing screws.
- (2) Provide 4 x M4 fixing screws.

3

# Operator Panels and Industrial PC

## Industrial Box PC Ordering Codes

### NUM Industrial Box PC Ordering Codes

BoxPC Version	Ordering Codes
BoxPC P1 CF RT CAN NVRAM	FXPC002NN1CDR00
BoxPC P1 CF RT	FXPC002NN1CNR00
BoxPC P2 HD RT CAN NVRAM	FXPC002NN2HDR00
BoxPC P2 HD RT	FXPC002NN2HNR00
BoxPC P2 HD RT CAN NVRAM W8.1	FXPC002NN2HDR10
BoxPC P2 HD RT W8.1	FXPC002NN2HNR10

	FXPC	00	2	N	N	2	H	D	R	1	0
<b>Display Unit</b>											
- Industrial Box PC		00									
<b>Panel/Mechanical Variant</b>											
- Second generation			2								
<b>Display Sensor</b>											
- No touch sensor, just Box PC				N							
<b>Keyboard Type</b>											
- No keyboard, just Box PC					N						
<b>IPC Mother Board, Processor</b>											
- Performance level P1						1					
- Performance level P2						2					
<b>Mass Memory Type</b>											
- Compact Flash <sup>1</sup>							C				
- HD (Hard Disk) <sup>2</sup>							H				
<b>Option Board</b>											
- No fieldbus								N			
- CAN + NVRAM								D			
<b>Flexium RTS</b>											
- Real time									R		
<b>Operating System</b>											
- Windows XP Kernel										0	
- Windows 8 Kernel <sup>2</sup>										1	
<b>Spare Number</b>											0

<sup>1</sup> For performance level P1 only

<sup>2</sup> For performance level P2 only



### nPad Mobile Operator Panel

The NUM nPad Mobile Operator Panel is a small, light and comfortable-to-hold remote system controller. When appropriately configured and connected to a machine's control and safety logic, it allows machine setup and operation, and execution of safety-related functions, to be commanded remotely.

The nPad Mobile Operator Panel is equipped with the Windows CE operating system and a CoDeSys HMI.

A communication library enables signals from the handwheel, touch buttons, selector, override potentiometers and other functions to access the nPad hardware.

Only one software toolset – Flexium Tools – is needed for graphical editing and programming, pattern design and system integration. The same toolset is used for NCK/Drive configuration and PLC programming. Advanced features include multi-language visualization support, and the graphical touch panel software can be simulated even in the absence of nPad hardware.

The safety-related devices available on the nPad are:

- Emergency Stop pushbutton
- Enabling device switch (dead-man's button)
- State Selector switch

The nPad features a powerful processor that is widely used in industrial products, together with a high reliability solid state disk and a robust and easy-to-use 5" TFT LCD touch-sensitive color display, housed in a compact handheld unit. A top-mounted USB 2.0 port is provided.

nPad also provides 19 soft-keys, 2 override potentiometers, a handwheel and a BCD selector, as well as Emergency Stop and Dead Man's buttons.

All configuration and control commands from the keyboard or touch screen display, together with signals from the handwheel and override potentiometers, are sent to the machine's control logic via Ethernet.

Safety related signals from the Emergency Stop pushbutton, Enabling Device and State Selector outputs are hard-wired to the machine's safety logic by dedicated cabling.

NUM's nPad Mobile Operating Panel is designed, developed and manufactured for conventional use in industry.

# Operator Panels and Industrial PC

## nPad Product Overview

### nPad Mobile Operator Panel Product Overview



# Operator Panels and Industrial PC

## nPad Technical Characteristics

### nPad Mobile Operator Panel Technical Characteristics

Emergency Stop Button	2 N.C contacts
Enabling Device	3-position switch, 2 N.O. contacts
State Selector	16 state BCD coded
Handwheel	40 counts per turn
Override Potentiometer	2 potentiometers
CPU and Electronics	<ul style="list-style-type: none"> <li>• 600MHz ARM Cortex-A8 core</li> <li>• 16kB instruction Cache</li> <li>• 256kB L2 Cache</li> <li>• Embedded Graphics engine</li> </ul>
Flash Memory	128 MB Flash NOR Solid State Disk (SSD)
RAM Memory	128 MB DDR2 SDRAM
Ethernet Interface	<ul style="list-style-type: none"> <li>• 10/100 Mbps Fast Ethernet</li> <li>• Fulfils standards: IEEE 802.3, IEEE 802.3u 100BASE-TX</li> <li>• Supports auto cross-over function (AUTO-MDI)</li> <li>• Connection: 2 shielded twisted pairs</li> </ul>
USB Interface	<ul style="list-style-type: none"> <li>• USB 2.0 HOST</li> <li>• max 500mA</li> <li>• USB type-A</li> </ul>
Keyboard	<p>The mobile panel has a rubber keypad containing 19 keys:</p> <ul style="list-style-type: none"> <li>• 6 keys are command keys, useful for direct machine control</li> <li>• The remaining 13 keys are function keys, useful for navigating and operating through the panels of the software application</li> <li>• The letter or symbol printed on each key illustrates its function</li> </ul>
Display	<p>TFT LCD:</p> <ul style="list-style-type: none"> <li>• Diagonal 5" (12.7 cm)</li> <li>• Colours: 16 millions</li> <li>• Resolution: RGB 480x272 pixels</li> <li>• Contrast ratio: 500:1</li> <li>• Viewing angle: <ul style="list-style-type: none"> <li>- Horizontal: Direction Right / Direction Left = 70°</li> <li>- Vertical: Direction Up = 50° / Direction Down = 70°</li> </ul> </li> <li>• Brightness: 300 cd/m<sup>2</sup></li> <li>• Half-brightness time: at least 20000 hours</li> <li>• Touch screen technology: Resistive sensor technology</li> </ul>
Status LED	<p>Bicolor LED: Red / Green</p> <ul style="list-style-type: none"> <li>• 2 LEDs: <ul style="list-style-type: none"> <li>- RED color: indicates hardware failures</li> <li>- GREEN color: may be fixed or blinking and is controlled by OS</li> </ul> </li> <li>• Touch screen TFT LCD Display</li> </ul>

# Operator Panels and Industrial PC

## nPad Technical Characteristics

### nPad Mobile Operator Panel Technical Characteristics

Power Supply	<ul style="list-style-type: none"> <li>• Rated voltage : 24 VDC +/-25%</li> <li>• Max interruption of the supply : 10 ms</li> <li>• Starting current: 250 mA @ 24V</li> <li>• Power consumption: 3.12W (typ) = 130mA @ 24V</li> <li>• Electrical insulation: No</li> </ul>
Overall Dimensions (L, H, W)	220 x 50 x 130 mm
Weight	730 g (without cable and without handstrap)
Temperature	<ul style="list-style-type: none"> <li>• Operating temperature: +5° to +45°C</li> <li>• Transport and storage temperature: -20° to +70°C</li> </ul>
Relative Humidity	<ul style="list-style-type: none"> <li>• Operating: Max 95% non-condensing</li> <li>• Transport: Max 95% non-condensing</li> </ul>
Vibration and Shock during Operation	Fulfils EN 60204/A1:2009 (par. 4.4.8), EN 61131-2:2007 (par. 4.2.2), EN 60068-2-31:2008
Operating Altitude	Max 3000 m
Degree of Protection	IP64
Housing and Chemical Resistance	Vibration and shock resistant according to EN 60204/A1:2009 (par. 4.4.8)
	Non-flammable material housing (fulfils UL 94-5VA)
	Extremely robust housing. Drop-tested according to EN 60068-2-31:2008
	Body structure: RAL 7035
	Rubber part: RAL 7016
	nPad has been designed to withstand to aggressive fluids such as: Denatured Ethyl Alcohol, Diesel, Gasoline, Silicon, Acetone and various fluids used for cooling

# Operator Panels and Industrial PC

nPad  
Outlines



## nPad Mobile Operator Panel Outlines

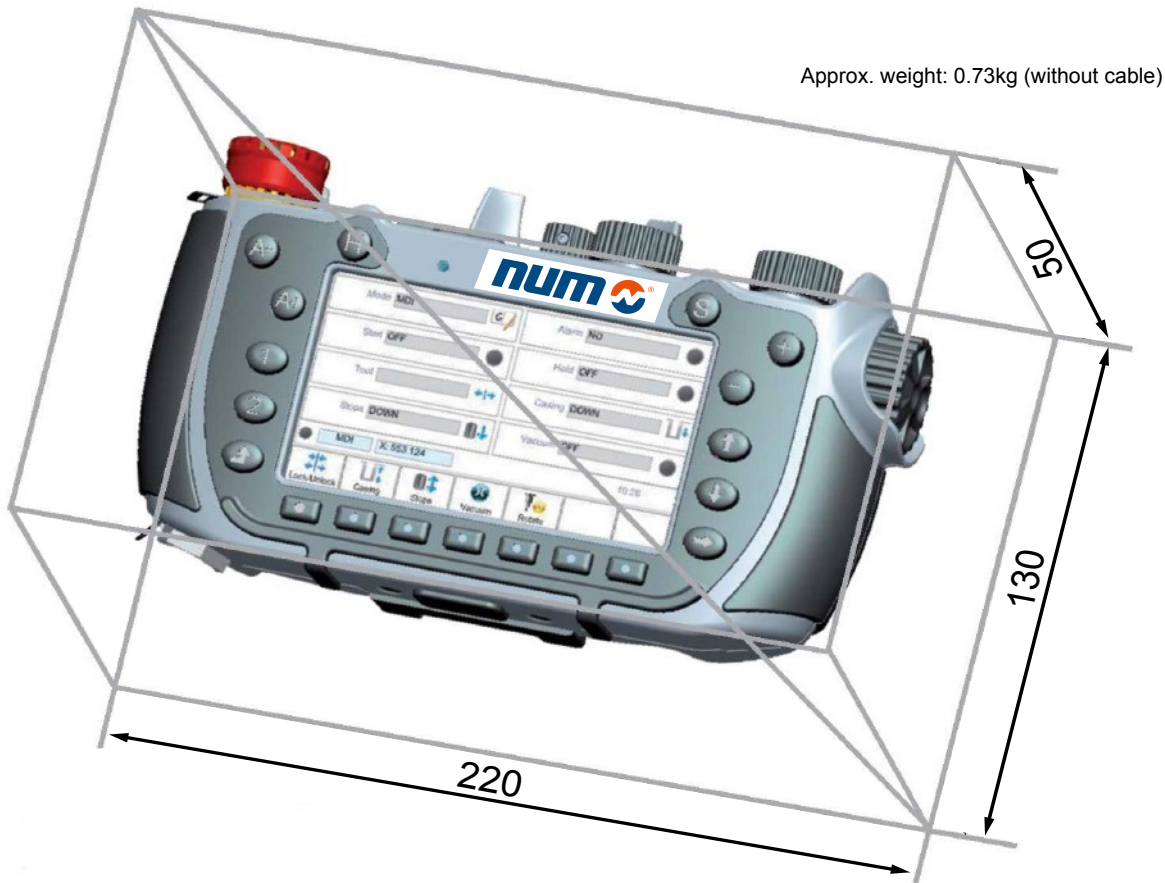

3

# Operator Panels and Industrial PC

## nPad Ordering Codes

### nPad Mobile Operator Panel Ordering Codes

	NPAD	05	2	R	E	1	S	H	0	D	1
<b>Display Unit</b>											
- LCD 05"		05									
<b>Panel/Mechanical Variant</b>											
- Variant			2								
<b>Display Sensor</b>											
- Touch Screen resistive				R							
<b>Connection Technology</b>											
- Wired (Ethernet + wires)					E						
- Wireless (Wi-Fi + BlueTooth)					W						
<b>Processor Performance</b>											
- Performance level P1						1					
<b>Safety Functions</b>											
- E-Stop, Enabling Device and State selector							S				
<b>Handwheel</b>											
- H								H			
<b>Options</b>											
- Standard									0		
<b>Cable Length</b>											
- Wireless version										0	
- 10 m											D
<b>Cable Termination (for wired version only)</b>											
- Wireless version											0
- Cable gland and free wires											1

The nPad package does not include the NPADA001 terminal connector, which if required, must be ordered separately.

## HBA-X Portable Handwheel

### HBA-X Portable Handwheel

The HBA-X portable handwheel for Flexium+ provides a number of operation functions:

- Axis selection
- Hand mode and speed selection
- Forward/backward movement and speed override
- Handwheel
- 3 step acknowledge button (Enabling Device “dead-man’s button”)
- Connection to the system for Flexium+ 6, 8 and 68 via cable and IO modules
- Buttons and switches: via I/Os
- Handwheel: directly to the Flexium+ NCK
- Enabling Device (Dead-man’s) button: into the safety circle

Connection to the Flexium+ system can be made in two different ways:

- HBA-Xc (5V) (FXHE181121):  
can be connected either directly to the Flexium+ NCK or by means of EtherCAT and the terminal CTMT5101.
- HBA-Xd (24V) (FXHE181122):  
can be connected by means of EtherCAT and the terminal CTMT5151.

The connection through EtherCAT allows hot plug-in of the HBA-X device.



### HBA-X Portable Handwheel Description

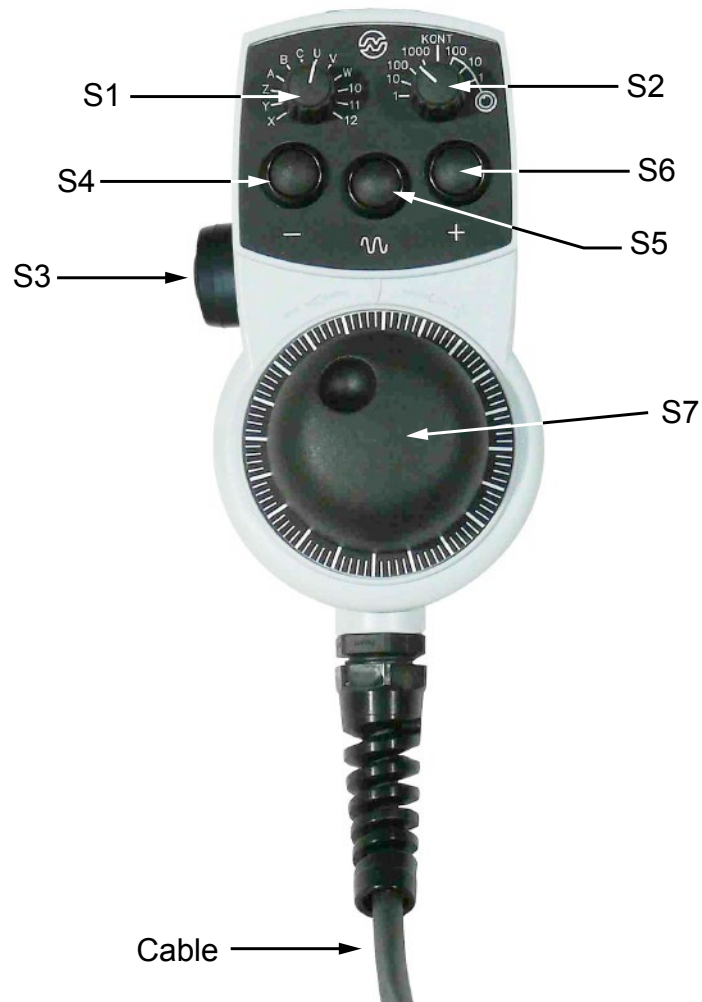

S1	Selector switch (12 position axis selection)
S2	Selector switch (8 position incremental selection and rate multiplier)
S3	3 stage acknowledge button Enabling Device (dead-man's button)
S4	Push button (negative)
S5	Push button (fast)
S6	Push button (positive)
S7	Handwheel
Cable	HBA-X cable + plug connector (23 pins M) together with a 23-pin F connector socket



### HBA-X Portable Handwheel Technical Characteristics

Handwheel	<ul style="list-style-type: none"> <li>• Impulse per revolution: 100</li> <li>• Supply voltage: 5 VDC <math>\pm</math> 5% for HBA-Xc / 24 VDC <math>\pm</math> 5% for HBA-Xd</li> <li>• Output circuit: 5 VDC or 24 VDC</li> </ul>
Push Button	<ul style="list-style-type: none"> <li>• Control element: 3 single closure</li> <li>• Switching voltage max: 30 VDC</li> <li>• Switching current max: 100mA</li> <li>• Switching power max: 1 W</li> </ul>
Acknowledge Button 3-Step	<ul style="list-style-type: none"> <li>• Control element: 1 double closure</li> <li>• Switching voltage max: 30 VDC</li> <li>• Switching current max: 1mA</li> <li>• Switching power max: 0.25 W</li> </ul>
Connection <sup>1,2</sup>	<ul style="list-style-type: none"> <li>• 23-pin connector</li> <li>• Cable 5 m</li> </ul>
Housing	<ul style="list-style-type: none"> <li>• Material: Plastic (polycarbonate)</li> <li>• Colour: Grey RAL 7040</li> <li>• Starting current: 250mA @ 24V</li> <li>• Power consumption: 3.12 W (typ) = 130mA @ 24V</li> <li>• Electrical insulation: No</li> </ul>
Overall Dimensions (L, H, W)	160 x 85 x 67 mm
Weight	Approx. 1.3 kg
Temperature	<ul style="list-style-type: none"> <li>• Operating temperature: 0 to +50°C</li> <li>• Transport and storage temperature: -20° to +50°C</li> </ul>
Relative Humidity	<ul style="list-style-type: none"> <li>• Operating: Max 95% non-condensing</li> <li>• Transport: Max 95% non-condensing</li> </ul>
Operating Altitude	Max 3000 m
Degree of Protection	IP65

<sup>1</sup> Different OEM handwheel locations may require an additional FXHE181310 socket for connection purposes

<sup>2</sup> Standard cable length is:

- 5 m for straight cable

Maximum distance from CNC is 40 m

# Operator Panels and Industrial PC

## HBA-X Portable Handwheel Outlines

### HBA-X Portable Handwheel Outlines

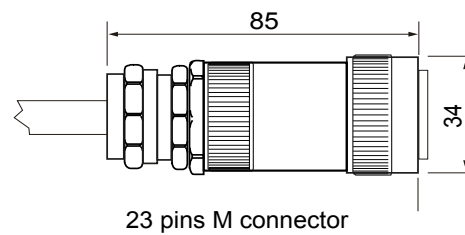
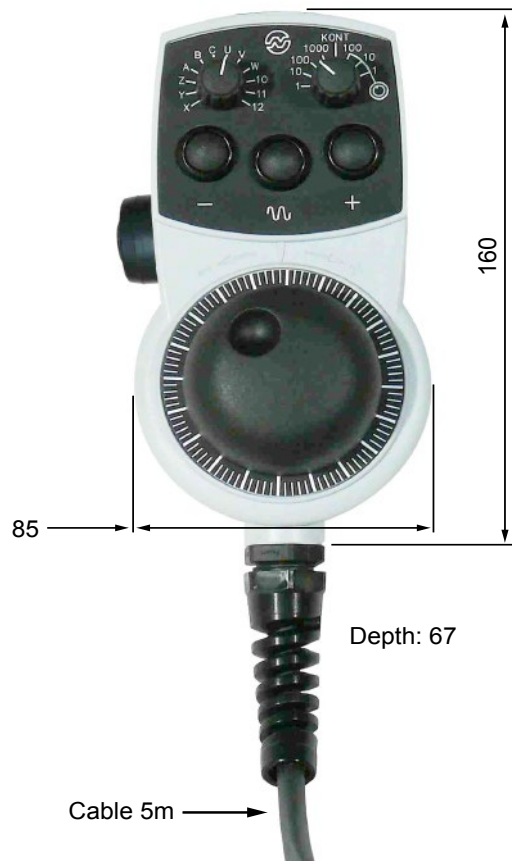

# Operator Panels and Industrial PC

HBA-X Portable Handwheel  
Ordering Codes



## Portable Handwheel HBA-X Ordering Codes

XBA Version	Ordering Codes
HBA-Xc (5V)	FXHE181121
HBA-Xd (24V)	FXHE181122

3



	Page
<b>Description</b>	<b>129</b>
<b>General Characteristics</b>	<b>131</b>
<b>Dimensions and Ordering Code</b>	<b>132</b>



# Flexium+ NCK

## Description

### Flexium+ NCK

Flexium+ NCK is the heart of a system. In a compact design compatible in size with the NUMDrive C components it packs a powerful engine, up to 40MB of user's memory, the connectivity for up to 32 digital axes or spindles and the PLC link, all delivered on standard RJ45 ports.

Additional Ethernet and clock synchronization ports for multi NCK operation, two analog axis ports, two probing inputs as well as sixteen digital inputs, sixteen digital outputs all with direct part program access, four analog inputs and two analog outputs complete this unit.

The Flexium+ NCK (Numerical Control Kernel) is the key unit of the CNC system, which uses the CNC software to manage part programs and machining data, to compute paths and speeds and to monitor axis movements.

CNC units can be linked together in a global configuration, whereby, for example, large transfer systems with more than 200 interpolating axes can be easily implemented.

Integrating machine control panels, inputs and outputs, handwheels, positioning axes and more is easy, thanks to the versatility of the field bus interfaces. The NCK hardware is identical between Flexium+ 6, Flexium+ 8 and Flexium+ 68.

Some features such as analog axes and handwheels require a software option.

4

NCK Front View

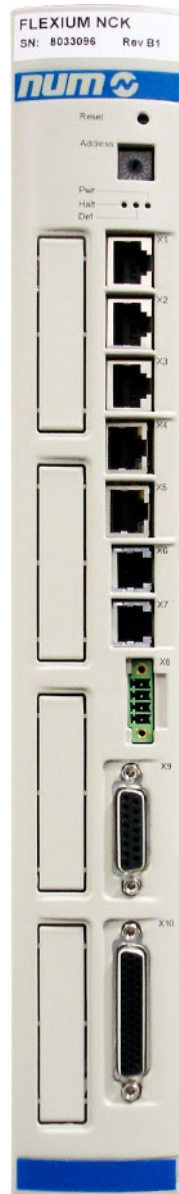

NCK Top View



NCK Bottom View



### NCK Module Description

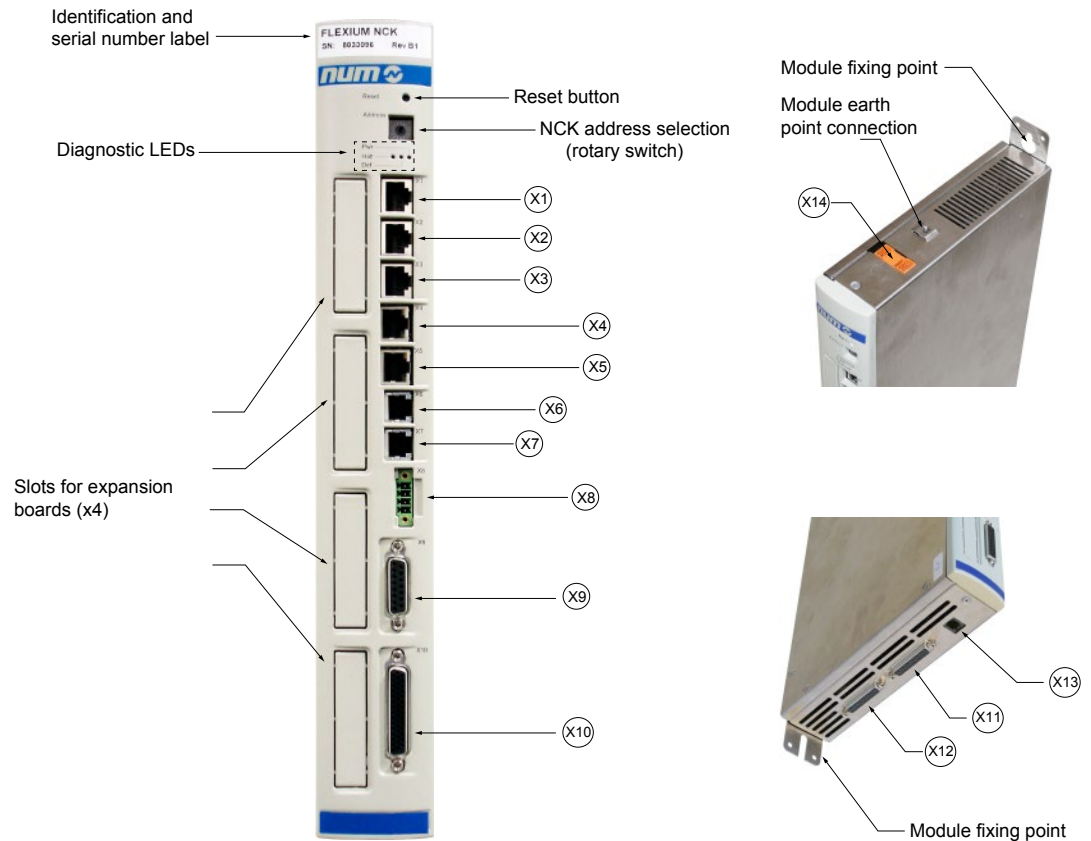

Connector	Description
X1, X2, X3	3 DISC NT+ rings (NCK to NUMDrive connection)
X4	Do not use
X5	Ethernet port for operator panel FS153 connection
X6	NCK clock output
X7	NCK clock input
X8	Watchdog interface connections: 12VDC/100mA + 30VDC/1A or 250VAC/1A
X9	Analog I/Os: - 2 outputs 16bits +/-10VDC - 4 inputs 12bits -10/0 ...10VDC
X10	Digital I/Os: 16 inputs 24VDC, 16 outputs 24VDC / 1A or Probing 2 inputs 24VDC
X11	1 Analog axis or Handwheel connections: - Reference: ±10VDC 16bits
X12	- Measure: quadrature complemented incremental encoder with zero pulse
X13	Serial port for debug (internal use only)
X14	Power supply connections: - 24VDC 1A

### General Characteristics

Flexium+ NCK		
Power Supply	Rated voltage	24 VDC +20% -15% or 48 VAC 35kHz
	Power consumption	24 VDC (0.5A), 12W
Analog Inputs	4 analog inputs available	
	Input impedance	40kΩ
	Resolution	12 bits
	Input voltage range	0 / +10V
Analog Outputs	2 analog outputs available	
	Output voltage range	- 10V / +10V
	Minimum load	2kΩ
	Resolution	16 bits
Digital Inputs	16 digital input available	
	Rated voltage	24 VDC
	Voltage limits	- 30 to 35 V
	Maximum current	6mA per input
	Operating voltage ranges	- Low-level: 0-5 V (current < 1mA) - High-level: 15-30 V (2.8mA < current < 4.3mA)
	Reverse voltage withstand	30 VDC permanent
	Response time	100µs
	Sampling period	2ms
	Logic	Positive (current sink)
	Protection	Complying with: IEC 62000-4-5, IEC 61000-4-4, IEC 61000-4-6
Digital Outputs	16 digital output available	
	Nominal voltage	24VDC (external power supply)
	Voltage range	15 - 35 VDC
	Maximum internal consumption current	30mA
	Rated voltage	24 VDC (external power supply)
	Rated current	250mA per output
	Maximum current (at 40°C maximum)	0.5A per output
	Maximum consumption current	8A for all outputs (protection by fuse)
	Delay on the resistance load (I=0.5 A)	250µs
	Protection per output	Overload and short-circuit (thermal circuit-breaker)
Digital Inputs for Probing	2 digital inputs available	
	Maximum operational current	2mA
	Minimum current required	1mA
	Input on 24V	- Low-level voltage: between 0 and 4.7V - High-level voltage: between 18 and 27V
Analogue Axes	Maximum 2. Please refer to chapter 7 for more detailed information.	
Ambient Conditions	Operating temperature range	0°C to 40°C
	Climatic conditions storage	-25°C to 70°C
	Relative humidity, noncondensing	max 75%
Protection Class	IP 20	
Weight	ca. 2.2 kg	
Dimensions	W x H x D	50 x 355 x 206 mm

# Flexium+ NCK

## Dimensions and Ordering Code

### NCK Overall Dimensions

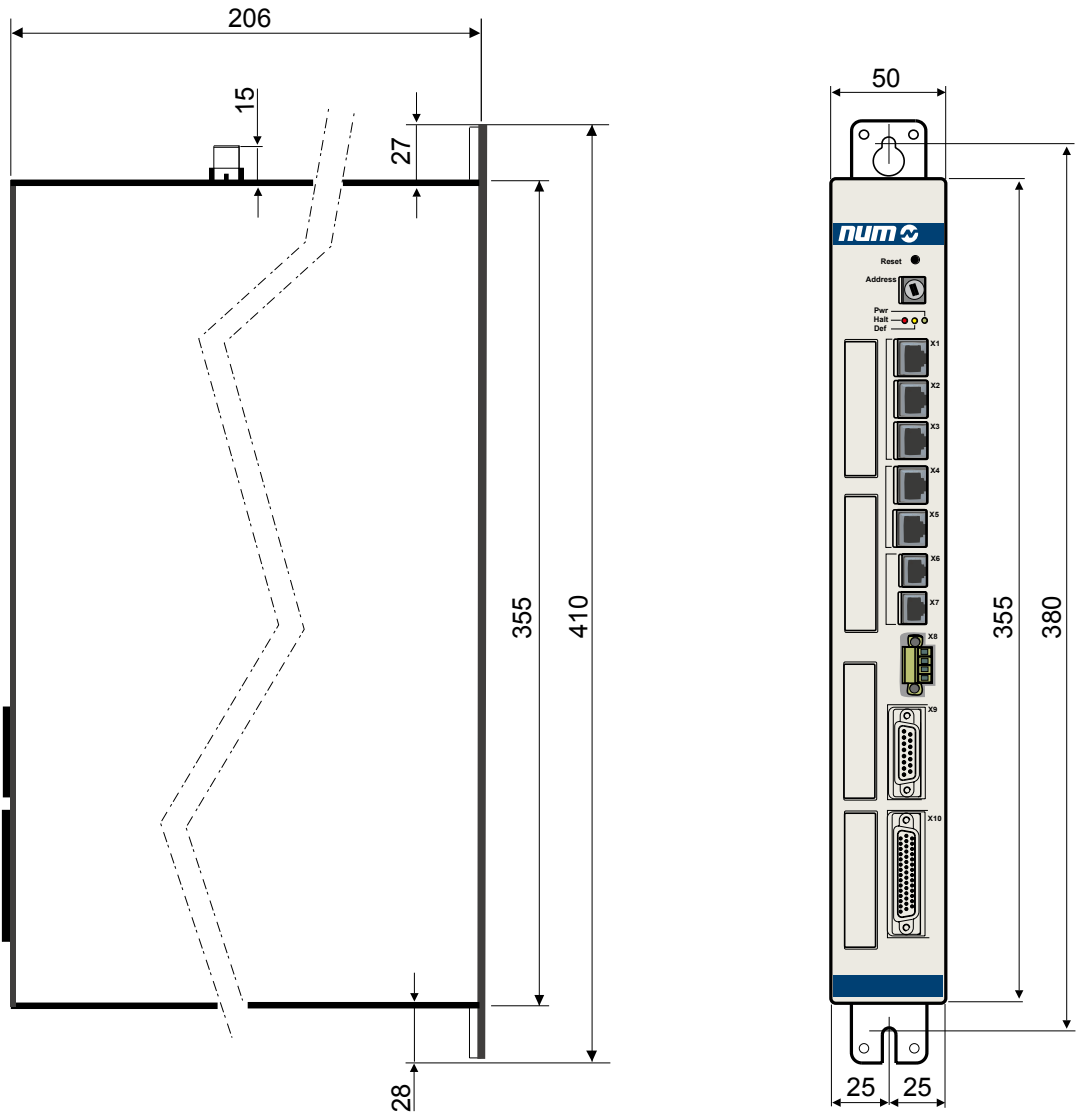

### NCK Ordering Code

Flexium+ NCK is included in the Flexium+ 6, Flexium+ 8 and Flexium+ 68 platform.

# NUMSafe PLC and Safe I/Os

## Table of Contents

	Page
<b>CTMP6900 - NUMSafe PLC</b>	<b>135</b>
Technical Characteristics	136
Outlines and Ordering Code	137
<b>CTMS1904 - NUMSafe Digital Inputs Terminal</b>	<b>138</b>
Technical Characteristics	139
Outlines and Ordering Code	140
<b>CTMS2904 - NUMSafe Digital Outputs Terminal</b>	<b>141</b>
Technical Characteristics	142
Outlines and Ordering Code	143



# NUMSafe PLC and Safe I/Os

## CTMP6900 - NUMSafe PLC

### CTMP6900 - NUMSafe PLC

The NUMSafe PLC controls the Safety PLC program and is connected in the same manner as any other EtherCAT terminal.

The CTMP6900 meets the requirements of IEC 61508 SIL 3 and EN 954 Cat. 4, DIN EN ISO 13849-1:2006 (Cat 4, PL e), NRTL, UL508, UL1998 and UL991.

The NUMSafe PLC has the typical design of an EtherCAT terminal.

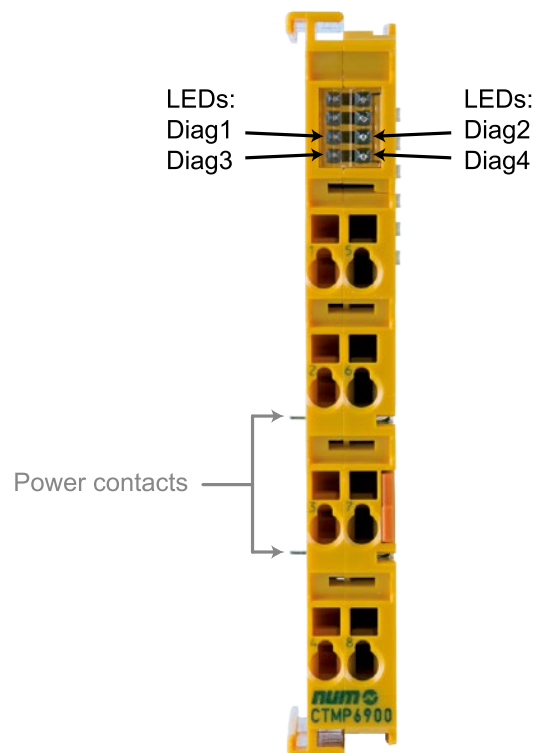

# NUMSafe PLC and Safe I/Os

## CTMP6900 - NUMSafe PLC Technical Characteristics



### CTMP6900 - Technical Characteristics

Product Name	CTMP6900
Number of Inputs	0
Number of Outputs	0
Status Display	4 diagnostic LEDs
Minimum Cycle Time	Approx. 500µs
Fault Response Time	≤ watchdog times
Watchdog Time	Min. 1ms, max. 60000ms
Input Process Image	Dynamic according to the NUMSafe configuration in "CODESYS Safety for EtherCAT Safety Module" programming system
Output Process Image	Dynamic according to the NUMSafe configuration in "CODESYS Safety for EtherCAT Safety Module" programming system
CTMP6900 Supply Voltage	From NUM EtherCAT Gateway CTMG1100
Current Consumption from the E-Bus	Approx. 188mA
Power Dissipation of the Terminal	Typically 1 W
Dimensions (W x H x D)	12 x 100 x 68 mm
Weight	Approx. 50 g
Permissible Ambient Temperature (Operation)	0°C to +55°C
Permissible Ambient Temperature (Transport / Storage)	-25°C to +70°C
Permissible Air Humidity	5% to 95%, non-condensing
Permissible Air Pressure (Operation / Storage / Transport)	750hPa to 1100hPa
Climate Class According to EN 60721-3-3	3K3
Permissible Contamination Level	Contamination level 2
Unacceptable Operating Conditions	NUMSafe terminals must not be used under the following operating conditions: - under the influence of ionizing radiation - in corrosive environments - in an environment that leads to unacceptable soiling of the EtherCAT terminal
Vibration / Shock Resistance	Conforms to EN 60068-2-6 / EN 60068-2-27, EN 60068-2-29
EMC Immunity / Emission	Conforms to EN 61000-6-2 / EN 61000-6-4
Shocks	15 g with pulse duration 11 ms in all three axes
Protection Class	IP20
Permitted Operating Environment	Control cabinet or terminal box with minimum protection class IP54 according to IEC 60529
Permissible Installation Position	Please refer to M00032 manual
Approvals	CE, cULus, ATEX

# NUMSafe PLC and Safe I/Os

CTMP6900 - NUMSafe PLC  
Outlines and Ordering Code

## CTMP6900 - Outlines

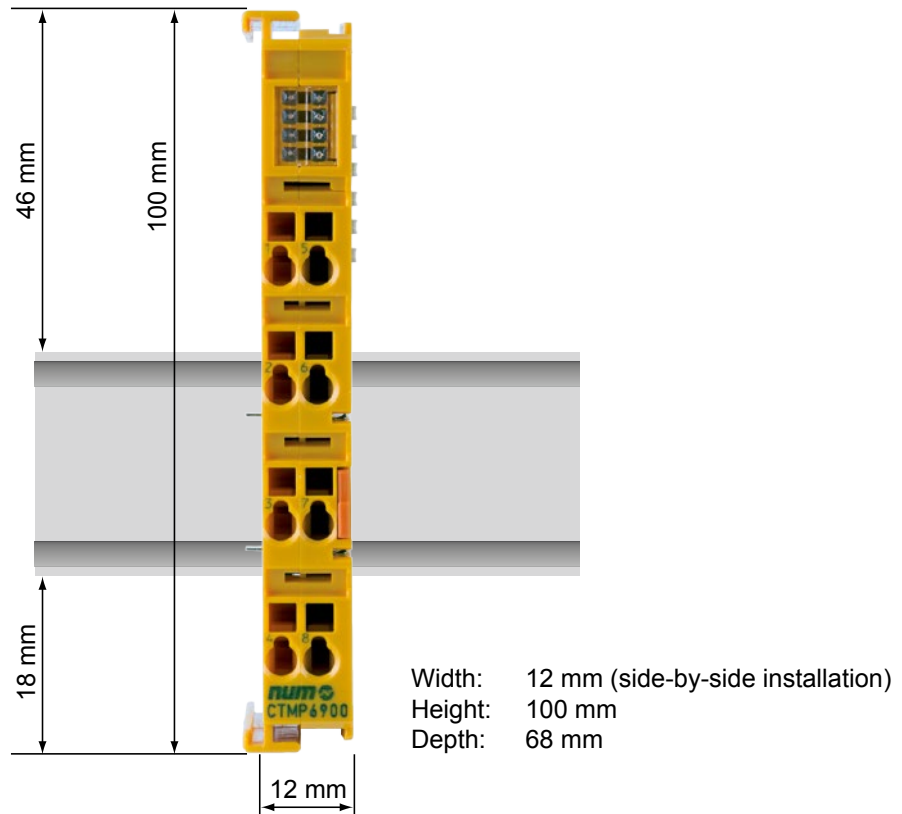

## CTMP6900 - Ordering Code

Product	Ordering Code
NUMSafe PLC	CTMP6900

# NUMSafe PLC and Safe I/Os

## CTMS1904 - NUMSafe Digital Inputs Terminal

### CTMS1904 - NUMSafe Digital Inputs Terminal

The CTMS1904 is a digital input terminal, with floating contacts for 24VDC.

The EtherCAT terminal has 4 fail-safe inputs.

With two-channel connection, the CTMS1904 meets the requirements of IEC 61508 SIL 3, EN 954, Cat 4, DIN EN ISO 13849-1:2006 (Cat 4, PL e), NRTL, UL508, UL1998 and UL991.

The NUMSafe Digital Inputs Terminal has the typical design of an EtherCAT terminal.

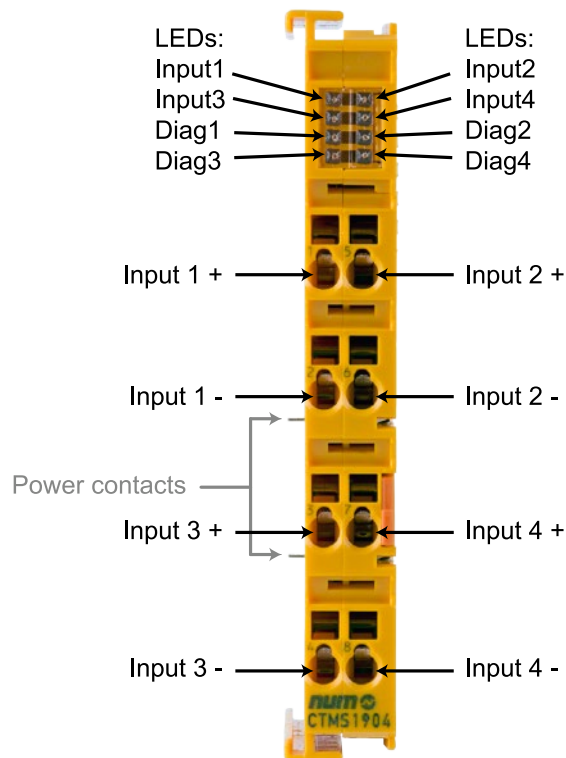

# NUMSafe PLC and Safe I/Os

## CTMS1904 - NUMSafe Digital Inputs Terminal Technical Characteristics

### CTMS1904 - Technical Characteristics

Product Name	CTMS1904
Number of Inputs	4
Number of Outputs	0
Response Time (Read Input / Write to E-Bus)	Typically: 4ms, maximum: see fault response time
Fault Response Time	≤ Watchdog time
Cable Length Between Actuator and Terminal (Unshielded), (Shielded)	100 m max.(at 0.75 or 1 mm <sup>2</sup> )
Input Process Image	6 bytes
Output Process Image	6 bytes
CTMS1904 Supply Voltage	From NUM EtherCAT Gateway CTMG1100
Current Consumption of the Modular Electronics at 24V (without Current Consumption of Sensors)	4 channels occupied: typically 12mA 0 channels occupied: typically 1.4mA
Current Consumption from the E-Bus	4 channels occupied: approx. 200mA
Power Dissipation of the Terminal	Typically 1 W
Electrical Isolation (Between the Channels)	No
Electrical Isolation (Between the Channels and the E-Bus)	Yes
Insulation Voltage (Between the Channels and the E-Bus, Under Common Operating Conditions)	Insulation tested with 500 VDC
Dimensions (W x H x D)	12 x 100 x 68 mm
Weight	Approx. 50 g
Permissible Ambient Temperature (Operation)	0°C to +55°C
Permissible Ambient Temperature (Transport / Storage)	-25°C to +70°C
Permissible Air Humidity	5% to 95%, non-condensing
Permissible Air Pressure (Operation / Storage / Transport)	750hPa to 1100hPa
Climate Class According to EN 60721-3-3	3K3
Permissible Contamination Level	Contamination level 2
Unacceptable Operating Conditions	NUMSafe terminals must not be used under the following operating conditions: - under the influence of ionizing radiation - in corrosive environments - in an environment that leads to unacceptable soiling of the EtherCAT Terminal
Vibration / Shock Resistance	Conforms to EN 60068-2-6 / EN 60068-2-27, EN 60068-2-29
EMC Immunity / Emission	Conforms to EN 61000-6-2 / EN 61000-6-4
Shocks	15 g with pulse duration 11ms in all three axes
Protection Class	IP20
Permitted Operating Environment	Control cabinet or terminal box with minimum protection class IP54 according to IEC 60529
Permissible Installation Position	Please refer to M00032 manual
Approvals	CE, cULus, ATEX

5

# NUMSafe PLC and Safe I/Os

CTMS1904 - NUMSafe Digital Inputs Terminal  
Outlines and Ordering Code

## CTMS1904 - Outlines

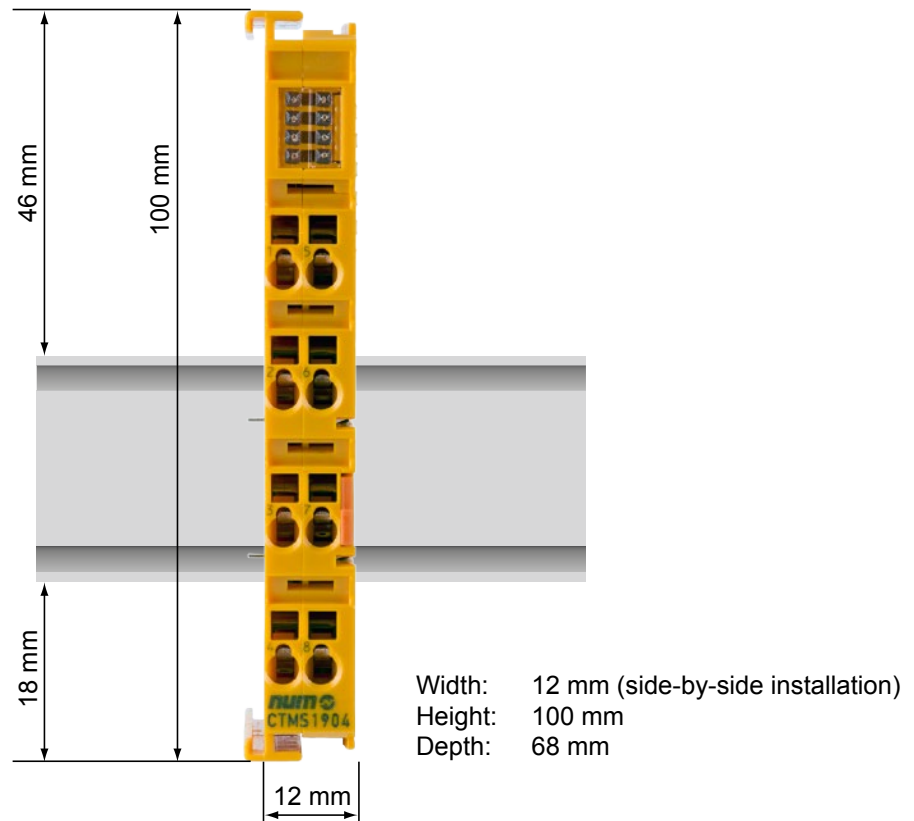

## CTMS1904 - Ordering Code

Product	Ordering Code
NUMSafe Digital Inputs Terminal	CTMS1904

# NUMSafe PLC and Safe I/Os

## CTMS2904 - NUMSafe Digital Outputs Terminal

### CTMS2904 - NUMSafe Digital Outputs Terminal

The CTMS2904 is a safe output terminal with digital outputs for connecting actuators (contactors, relays, etc.) with a maximum current 0.5A (24VDC).

The EtherCAT terminal has 4 fail-safe outputs.

The CTMS2904 meets the requirements of IEC 61508 SIL 3, EN 954 Cat 4, DIN EN ISO 13849-1:2006 (Cat 4, PL e), NRTL, UL508, UL1998 and UL991.

The NUMSafe Digital Outputs Terminal has the typical design of an EtherCAT terminal.

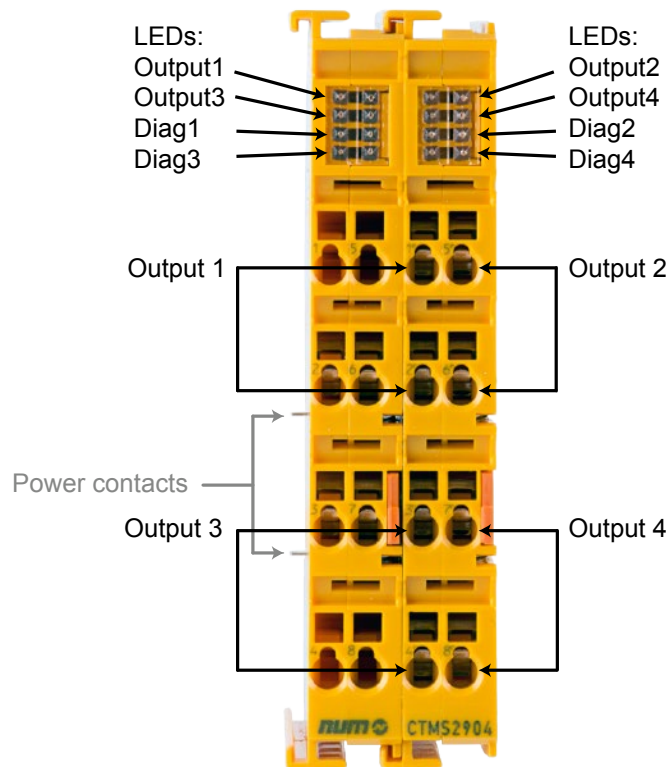

# NUMSafe PLC and Safe I/Os

## CTMS2904 - NUMSafe Digital Outputs Terminal Technical Characteristics

### CTMS2904 - Technical Characteristics

Product Name	CTMS2904
Permissible Contamination Level	0
Number of Outputs	4
Status Display	4 (one green LED per output)
Fault Response Time	≤ Watchdog times
Output Current per Channel	Max. 500mA, min. 20mA with current measurement active
Actuators	When selecting actuators please ensure that the CTMS2904 test pulses do not lead to actuator switching
Cable Length Between Actuator and Terminal (Unshielded), (Shielded)	Max. 100 m
Wire Cross Section	Min. 0.75 mm <sup>2</sup>
Input Process Image	6 bytes
Output Process Image	6 bytes
CTMS2904 Supply Voltage	From NUM EtherCAT Gateway CTMG1100
Current Consumption from the E-Bus	Approx. 221mA
Power Dissipation of the Terminal	Typically 2 W
Electrical Isolation (Between the Channels)	No
Electrical Isolation (Between the Channels and the E-Bus)	Yes
Insulation Voltage (Between the Channels and the E-Bus, Under Common Operating Conditions)	Insulation tested with 500 VDC
Dimensions (W x H x D)	24 x 100 x 68 mm
Weight	Approx. 100 g
Permissible Ambient Temperature (Operation)	0°C to +55°C
Permissible Ambient Temperature (Transport / Storage)	-25°C to +70°C
Permissible Air Humidity	5% to 95%, non-condensing
Permissible Air Pressure (Operation / Storage / Transport)	750hPa to 1100hPa
Climate Class According to EN 60721-3-3	3K3
Permissible Contamination Level	Contamination level 2
Unacceptable Operating Conditions	NUMSafe terminals must not be used under the following operating conditions: - under the influence of ionizing radiation - in corrosive environments - in an environment that leads to unacceptable soiling of the EtherCAT terminal
Vibration / Shock Resistance	Conforms to EN 60068-2-6 / EN 60068-2-27, EN 60068-2-29
EMC Immunity / Emission	Conforms to EN 61000-6-2 / EN 61000-6-4
Shocks	15 g with pulse duration 11ms in all three axes
Protection Class	IP20
Permitted Operating Environment	Control cabinet or terminal box with minimum protection class IP54 according to IEC 60529
Permissible Installation Position	Please refer to M00032 manual
Approvals	CE, cULus, ATEX

# NUMSafe PLC and Safe I/Os

CTMS2904 - NUMSafe Digital Outputs Terminal  
Outlines and Ordering Code

## CTMS2904 - Outlines

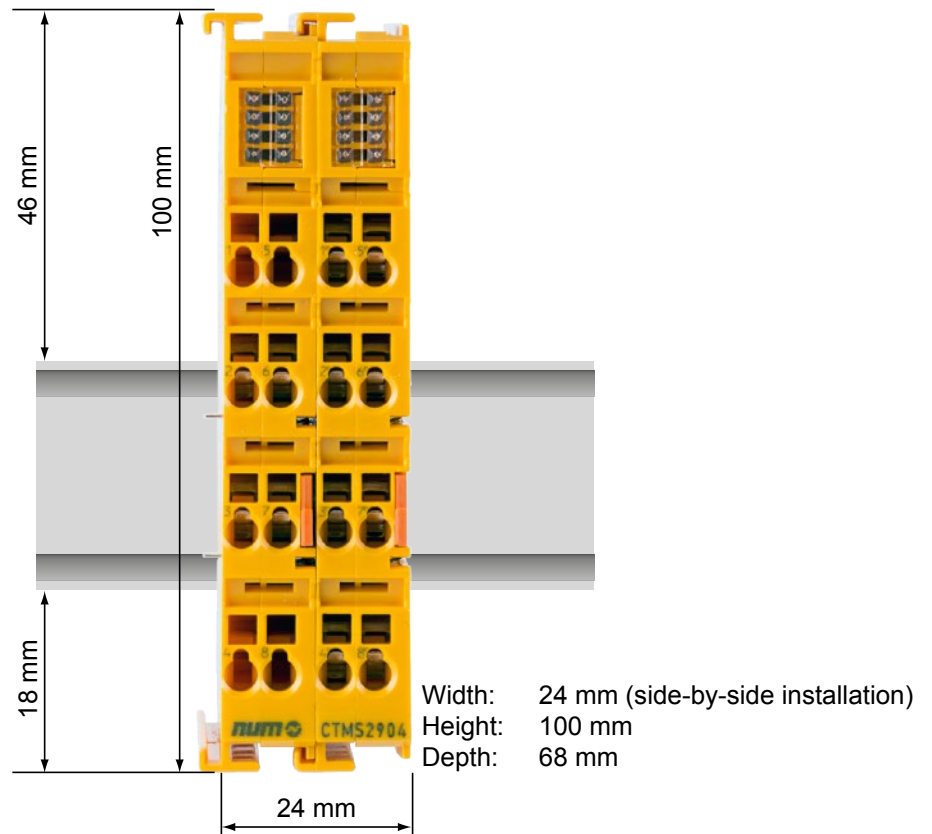

## CTMS2904 - Ordering Code

Product	Ordering Code
NUMSafe Digital Outputs Terminal	CTMS2904



	Page
<b>Overview and Product Positioning</b>	<b>147</b>
<b>BHX &amp; SHX Servomotors</b>	<b>149</b>
Characteristics	149
BHX - Ordering Codes	150
SHX - Ordering Codes	151
<b>BPX &amp; SPX Servomotors</b>	<b>152</b>
Characteristics	152
BPX - Ordering Codes	153
SPX - Ordering Codes	154
<b>BHX &amp; BPX Servomotors</b>	<b>155</b>
Outlines	155
<b>SHX &amp; SPX Servomotors</b>	<b>157</b>
Outlines	157
<b>BPH Servomotors</b>	<b>158</b>
General Characteristics	158
Technical Characteristics	159
Ordering Codes	160
<b>BPG Servomotors</b>	<b>161</b>
Characteristics	161
Ordering Codes	162
<b>BPH &amp; BPG Servomotors</b>	<b>163</b>
Outlines	163
<b>BHL Servomotors</b>	<b>164</b>
Characteristics	164
Ordering Codes	165
Outlines	166
<b>AMS &amp; IM Spindle Motors</b>	<b>167</b>
General Characteristics	167
Technical Characteristics	168
AMS Ordering Codes	169
IM Ordering Codes	170
Outlines	171
<b>Encoder Characteristics</b>	<b>173</b>
<b>Custom Motors</b>	<b>174</b>





### Overview and Product Positioning

NUM manufactures a comprehensive range of motors, all featuring high power-to-weight ratios and excellent dynamic range. Availability of a vast variety of motors enables NUM to provide solutions that are perfectly tailored to each application.

In conjunction with NUMDrive servo drives these motors offer excellent stability even at very low rotational speeds.

NUM motors are equipped with robust optical encoders of different resolution/accuracy levels to fit the requirements of the machine and the application.

Developed for use with NUM's latest-generation NUMDrive X digital servodrives and Flexium+ CNC platform, our innovative SHX and SPX brushless servomotors only require a single cable connection, providing major savings by eliminating the need for a separate encoder cable. Machine builders can now use a single drive-to-motor cable for each motion axis, thereby reducing cabling, speeding installation/commissioning, and improving system performance.

An innovative embedded digital interface scheme allows the encoder power and position feedback data – together with diagnostic information and thermal data from the motor's temperature sensor – to be carried on just two shielded wires contained within the motor's power cable. This approach has significant advantages for machine builders. In addition to lower cabling costs, cable chains are smaller and lighter, the onerous task of installing and debugging cable runs is much less time consuming, and the reduced number of interconnections improves reliability and immunity to electromagnetic interference.

NUM also offers a wide choice of built-in and liquid-cooled motors, including custom designed models. For details about any of these types of motors, please contact your local NUM sales office.

### Product Positioning

The different motor ranges are positioned as shown in the table below:

Motor Range	Main Characteristics	Typical Applications	Cont. Torque / Power Range	Available Frame Sizes	Available Options
<b>SHX</b>	Single cable servo-motor with very compact design, medium inertia, IP64	Designed for feeding axes of cost sensitive machine tools	From 1.2 Nm up to 20 Nm	75 mm 95 mm 126 mm 155 mm	Holding brake Keyed shaft Medium resolution SAFETY single/multi turn encoder High inertia version
<b>SPX</b>	Single cable servo-motor with extremely compact design, high peak torques, smooth operation, medium inertia, IP67	Designed for feeding axes of high-end machine tools, grinding machines, robotics and special machines	From 0.5 Nm up to 23 Nm	75 mm 95 mm 126 mm 155 mm	Holding brake Keyed shaft Medium resolution SAFETY single/multi turn encoder High inertia version
<b>BHX</b>	Very compact design, medium inertia, IP64 servomotor	Designed for feeding axes of cost sensitive machine tools	From 1.2 Nm up to 20 Nm	75 mm 95 mm 126 mm 155 mm	Holding brake Keyed shaft Medium and high resolution single/multi turn encoder High inertia version
<b>BPX</b>	Extremely compact design, high peak torques, smooth operation, medium inertia, IP67 servomotor	Designed for feeding axes of high-end machine tools, grinding machines, robotics and special machines	From 0.5 Nm up to 23 Nm	75 mm 95 mm 126 mm 155 mm	Holding brake Keyed shaft Medium and high resolution single/multi turn encoder High inertia version
<b>BPH</b>	Compact design, smooth operations, medium inertia, up to IP67 servomotor	Designed for feeding axes of high-end machine tools, grinding machines, robotics and special machines	From 1.3 Nm up to 100 Nm	75 mm 95 mm 115 mm 142 mm 190 mm	Holding brake Keyed shaft Medium and high resolution single/multi turn encoder IP67 degree of protection
<b>BPG</b>	Compact design, smooth operation, very high inertia, up to IP67 servomotor	Designed for feeding axes of high end machine tools, grinding machines, robotics and special machines	From 1.3 Nm up to 56 Nm	75 mm 95 mm 115 mm 142 mm 190 mm	Keyed shaft Medium and high resolution single/multi turn encoder IP67 degree of protection
<b>BHL</b>	Very compact design, high inertia, IP64 servomotor	Designed for feeding axes of large machine tools	From 85 Nm up to 160 Nm	260 mm	Holding brake Keyed shaft Medium and high resolution single/multi turn encoder
<b>AMS/IM</b>	Compact fan cooled spindle motor	Designed for main spindles	From 2.2 kW up to 55 kW	100 mm 132 mm 160 mm 180 mm shaft height	Keyed shaft High resolution single/multi turn encoder Low vibration level High radial loads

### General Characteristics

BHX and SHX servomotors are very compact medium inertia units, designed for the feeding axes of cost sensitive machine tools. They are available in 75 mm, 95 mm, 126 mm and 155 mm frame sizes, with a variety of options.

SHX servomotors are mechanically identical to BHX servomotors and have the same basic characteristics. However, thanks to an innovative encoder protocol, SHX servomotors only require a single cable to connect with NUMDrive X drives.

General Motor Features	As per EN60034-1
Environment Storage Conditions	
- Temperature Range	-20 to +80 °C
- Relative Humidity	max. 80% without condensation
Environment Working Conditions	
- Temperature Range	0 to 40 °C without derating, max. 55 °C with derating
- Altitude	0 to 1000 m without derating, max. 3000 m with derating
Continuous Stall Torque Range	From 1.2 to 11 Nm
Degree of protection as per EN60529	Housing IP64, shaft IP54
Connection	By rotary connector
Permanent Magnet Holding Brake	24 Vdc available as option (excluding for high inertia version)
Motor Transducer	High resolution single turn and multi turn optical encoder Medium resolution single turn and multi turn optical encoder Medium resolution single turn and multi turn optical encoder 2 wires (only for SHX and SPX) Medium resolution single turn and multi turn optical encoder 2 wires SIL 2 (only for SHX and SPX)
Mounting Restriction	No mounting restrictions, IMB5 - IMV1 - IMV3 as per EN60034-7
Finishing	Not painted, dielectric varnish only

### Technical Characteristics

For peak torque figures please refer to chapter 7 where the drive-motor associations are described.

BHX SHX	Low speed cont. torque	Rated speed	Rotor Inertia			Motor weight			Brake		Low speed cont. current	Dimen- sioning Power
			without brake	with brake	high inertia version	without brake	with brake	high inertia version	Torque	Current		
			[g.m <sup>2</sup> ]	[g.m <sup>2</sup> ]	[g.m <sup>2</sup> ]	[kg]	[kg]	[kg]	[Nm]	[A]		
0751V5...	1.2	6 000	0.07	0.08	0.12	2.1	2.3	2.4	2.2	0.4	1.7	0.75
0752V5...	2.1	6 000	0.13	0.14	0.18	3.1	3.3	3.4			3.1	1.32
0951V5...	2.4	6 000	0.20	0.26	0.54	3.4	4.1	4.3			3.0	1.51
0952N5...	4.3	3 000	0.37	0.43	0.71	4.8	5.5	5.7	6	0.7	2.8	1.35
0952V5...		6 000									5.6	2.70
1261N5...	4.5	3 000	0.55	0.69	1.49	5.5	7	7.2	13	0.8	3.2	1.41
1261V5...		6 000									6.4	2.83
1262N5...	8.4	3 000	1.07	1.21	2.01	8	9.5	9.7	13	0.8	6.0	2.64
1262V5...		6 000									12.0	5.28
1263R5...	11	4 500	1.58	1.72	2.52	10.6	12.1	12.3	29	0.9	10.0	5.18
1552N5...	12	3 000	2.45	2.86	5.25	11.6	13.8	14.3			7.5	3.8
1552R5...		4 500									10.2	5.7
1554N5...	20	3 000	4.76	5.17	7.56	18.2	20.4	20.9	29	0.9	12.4	6.3

# NUM Motors

BHX & SHX Servomotors  
 BHX - Ordering Codes



## BHX Servomotor Ordering Codes

	<b>BHX</b>	<b>075</b>	<b>1</b>	<b>V</b>	<b>5</b>	<b>Q</b>	<b>A</b>	<b>2</b>	<b>L</b>	<b>0</b>	<b>0</b>
<b>Series</b>											
<b>Size (075, 095, 126, 155)</b>											
<b>Length</b>											
<b>Winding type</b>											
<b>Connection type</b>											
- Standard right-angled M23 rotatable connectors					5						
<b>Sensor type</b>											
- High resolution multi-turn encoder						P					
- High resolution single-turn encoder						Q					
- Medium resolution multi-turn encoder						J					
- Medium resolution single-turn encoder						K					
<b>Brake</b>											
- Without brake							A				
- With brake							F				
- High inertia version <sup>1</sup>							G				
<b>Version</b>											
- Standard								2			
<b>Shaft extension</b>											
- Smooth									L		
- Keyed									C		
<b>Type of customization</b>											
- Standard										0	
<b>Degree of protection (shaft extension/frame)</b>											
- IP 54/64											0

<sup>1</sup> Brake option not available

# NUM Motors

BHX & SHX Servomotors  
SHX - Ordering Codes



## SHX Servomotor Ordering Codes

	SHX	075	1	V	5	3	A	2	L	0	0
<b>Series</b>											
<b>Size (075, 095, 126, 155)</b>											
<b>Length</b>											
<b>Winding type</b>											
<b>Connection type</b>											
- Standard right-angled M23 rotatable connectors					5						
<b>Sensor type</b>											
- Medium resolution multi-turn encoder 2-wires						I					
- Medium resolution single-turn encoder 2-wires						L					
- Medium resolution multi-turn encoder 2-wires SIL 2						3					
- Medium resolution single-turn encoder 2-wires SIL2						4					
<b>Brake</b>											
- Without brake							A				
- With brake							F				
- High inertia version <sup>1</sup>							G				
<b>Version</b>											
- Standard								2			
<b>Shaft extension</b>											
- Smooth									L		
- Keyed									C		
<b>Type of customization</b>											0
- Standard											0
<b>Degree of protection (shaft extension/frame)</b>											
- IP 54/64											0

<sup>1</sup> Brake option not available

## BHX & SHX Servomotor Outlines

See pages 155-157 for BHX, SHX, BPX & SPX servomotor outlines.

6

# NUM Motors

## BPX & SPX Servomotors Characteristics

### General Characteristics

BPX and SPX servomotors are extremely compact medium inertia units with a high peak torque capability, designed for the feeding axes of high-end machine tools, grinding machines, robotics and special machines. They are available in 55 mm, 75 mm, 95 mm, 126 mm and 155 mm frame sizes, with a variety of options.

SPX servomotors are mechanically identical to BPX servomotors and have the same basic characteristics. However, thanks to an innovative encoder protocol, SPX servomotors only require a single cable to connect with NUMDrive X drives.

General Motor Features	As per EN60034-1
Environment Storage Conditions	
- Temperature Range	-20 to +80 °C
- Relative Humidity	max. 80% without condensation
Environment Working Conditions	
- Temperature Range	0 to 40 °C without derating, max. 55 °C with derating
- Altitude	0 to 1000 m without derating, max. 3000 m with derating
Continuous Stall Torque Range	From 0.5 to 12.6 Nm
Degree of protection as per EN60529	IP67 (Excluding BPX055)
Connection	By rotary connector
Permanent Magnet Holding Brake	24 Vdc available as option (excluding the high inertia version)
Motor Transducer	High resolution single turn and multi turn optical encoder Medium resolution single turn and multi turn optical encoder Medium resolution single turn and multi turn optical encoder 2 wires (for SHX only) Medium resolution single turn and multi turn optical encoder 2 wires SIL 2 (for SHX only)
Mounting Restriction	No mounting restrictions, IMB5 - IMV1 - IMV3 as per EN60034-7
Finishing	Black glossy polyurethane varnish

### Technical Characteristics

For peak torque figures please refer to chapter 7 where the drive-motor associations are described.

BPX SPX	Low speed cont. torque	Rated speed	Rotor Inertia			Motor weight			Brake		Low speed cont. current	Dimen- sioning Power
			without brake	with brake	high inertia version	without brake	with brake	high inertia version	Torque	Current		
			[g.m <sup>2</sup> ]	[g.m <sup>2</sup> ]	[g.m <sup>2</sup> ]	[kg]	[kg]	[kg]	[Nm]	[A]		
0551V5...	0.5	6 000	0.006	0.008	-	1.2	1.4	-	0.8	0.4	0.7	0.31
0751V5...	1.4	6 000	0.07	0.08	0.12	2.2	2.4	2.5	2.2	0.4	2.0	0.88
0752V5...	2.3	6 000	0.13	0.14	0.18	3.2	3.4	3.5			3.4	1.45
0951V5...	2.7	6 000	0.20	0.26	0.54	3.6	4.3	4.5	6	0.7	3.4	1.70
0952N5...	5.0	3 000	0.37	0.43	0.71	5.2	5.9	6.1			3.3	1.57
0952V5...		6 000									6.6	3.14
1261N5...	5.2	3 000	0.55	0.69	1.49	6.0	7.5	7.7	13	0.8	3.7	1.63
1261V5...		6 000									7.4	3.27
1262N5...	9.8	3 000	1.07	1.21	2.01	8.5	10	10.2			7.0	3.08
1262V5...		6 000							14.0	6.16		
1263R5...	12.6	4 500	1.58	1.72	2.52	11.2	12.7	12.9	29	0.9	11.5	5.94
1552N5...	13.8	3 000	2.45	2.86	5.25	12.5	14.7	15.2			8.7	4.34
1552R5...		4 500									11.7	6.50
1554N5...	23	3 000	4.76	5.17	7.56	19.1	21.3	21.8	14.2	7.23		

# NUM Motors

BPX & SPX Servomotors  
BPX - Ordering Codes

## BPX Servomotor Ordering Codes

	<b>BPX</b>	<b>075</b>	<b>1</b>	<b>V</b>	<b>5</b>	<b>Q</b>	<b>A</b>	<b>2</b>	<b>L</b>	<b>0</b>	<b>2</b>
<b>Series</b>											
<b>Size</b> (055, 075, 095, 126, 155)											
<b>Length</b>											
<b>Winding type</b>											
<b>Connection type</b>											
- Standard right-angled M23 rotatable connectors					5						
<b>Sensor type</b>											
- High resolution multi-turn encoder <sup>3</sup>						P					
- High resolution single-turn encoder <sup>3</sup>						Q					
- Medium resolution multi-turn encoder						J					
- Medium resolution single-turn encoder <sup>3</sup>						K					
<b>Brake</b>											
- Without brake							A				
- With brake							F				
- High inertia version <sup>1,4</sup>							G				
<b>Version</b>											
- Standard								2			
<b>Shaft extension</b>											
- Smooth									L		
- Keyed									C		
<b>Type of customization</b>											
- Standard										0	
<b>Degree of protection (shaft extension/frame)</b>											
- IP 65/65 <sup>2</sup>											1
- IP 67/67											2

<sup>1</sup> Brake option not available

<sup>2</sup> Mandatory choice for BPX055, not available for other sizes

<sup>3</sup> Sensor type not available for BPX055

<sup>4</sup> Option not available for BPX055

# NUM Motors

BPX & SPX Servomotors  
SPX - Ordering Codes

## SPX Servomotor Ordering Codes

	SPX	075	1	V	5	3	A	2	L	0	2
<b>Series</b>											
<b>Size</b> (075, 095, 126, 155)											
<b>Length</b>											
<b>Winding type</b>											
<b>Connection type</b>											
- Standard right-angled M23 rotatable connectors					5						
<b>Sensor type</b>											
- Medium resolution multi-turn encoder 2-wires						I					
- Medium resolution single-turn encoder 2-wires						L					
- Medium resolution multi-turn encoder 2-wires SIL 2						3					
- Medium resolution single-turn encoder 2-wires SIL 2						4					
<b>Brake</b>											
- Without brake							A				
- With brake							F				
- High inertia version <sup>1</sup>							G				
<b>Version</b>											
- Standard								2			
<b>Shaft extention</b>											
- Smooth									L		
- Keyed									C		
<b>Type of customization</b>											
- Standard										0	
<b>Degree of protection (shaft extension/frame)</b>											
- IP 67/67											2

<sup>1</sup> Brake option not available

# NUM Motors

## BHX & BPX Servomotors Outlines

### Servomotor Outlines

**bhx**  
**bpX**

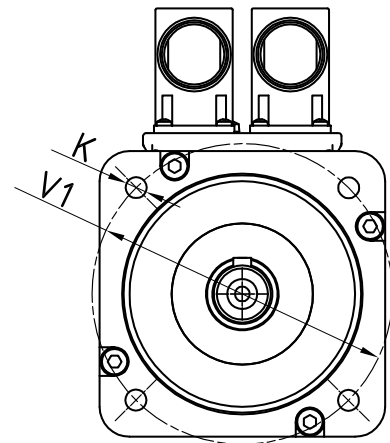
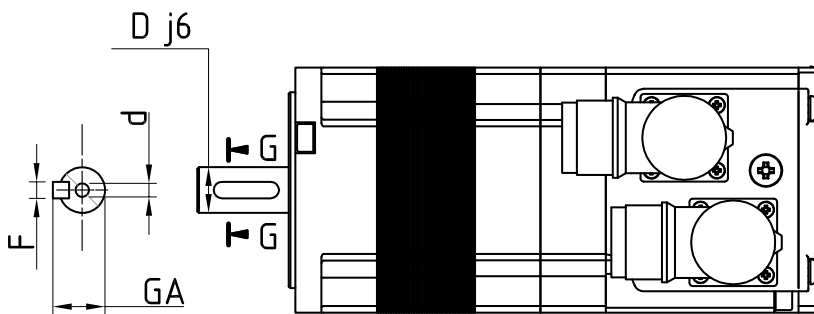
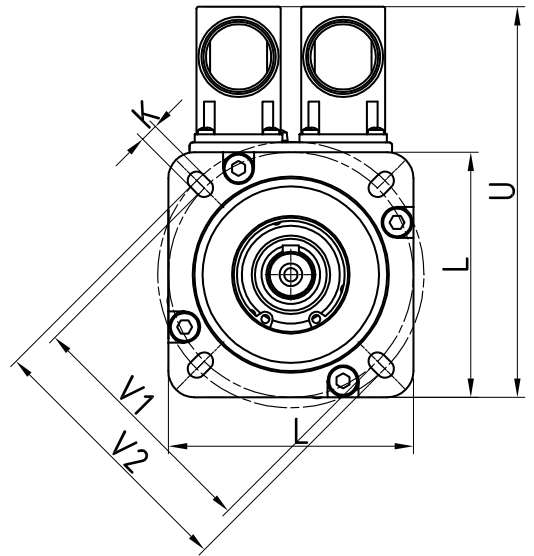
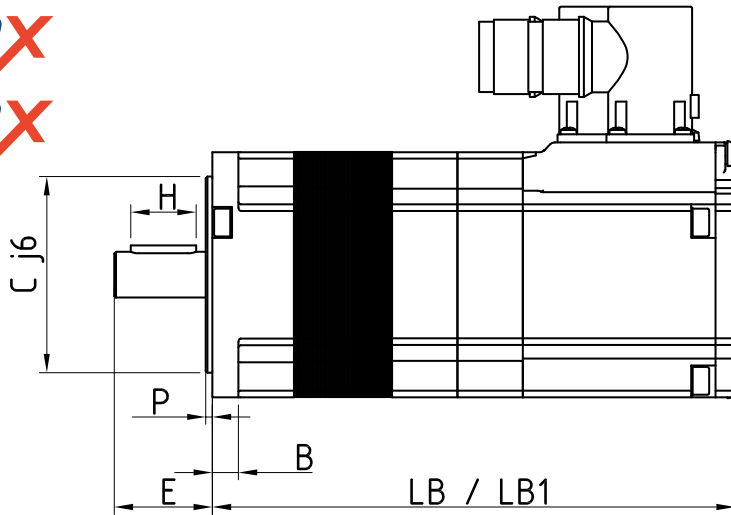

6

BHX BPX	L	LB*	LB1*	C	P	B	V1	V2	K	U	D	E	H	F	GA	d
	[mm]	[mm]	[mm]	[mm]	[mm]	[mm]	[mm]	[mm]	[mm]	[mm]	[mm]	[mm]	[mm]	[mm]	[mm]	[mm]
0751..	75	140	160	60	2.5	8	75	81.5	5.5	119.5	14	30	20	5	16	M5x10
0752..		170	190													
0951..	95	153	183	80	3	10	100	---	7	140.5	19	40	30	6	21.5	M6x16
0952..		183	213													
1261..	126	149	194	110	3.5	11	130	---	9	175	24	50	40	8	27	M8x19
1262..		179	224													
1263..		209	254													
1552..	155	192	235	130	3.5	13	165	---	11	200	32	58	45	10	35	M12x28
1554..		242	285													

\* LB without brake, LB1 with brake or high inertia version

# NUM Motors

## BHX & BPX Servomotors Outlines

### BPX 055 Servomotor Outlines

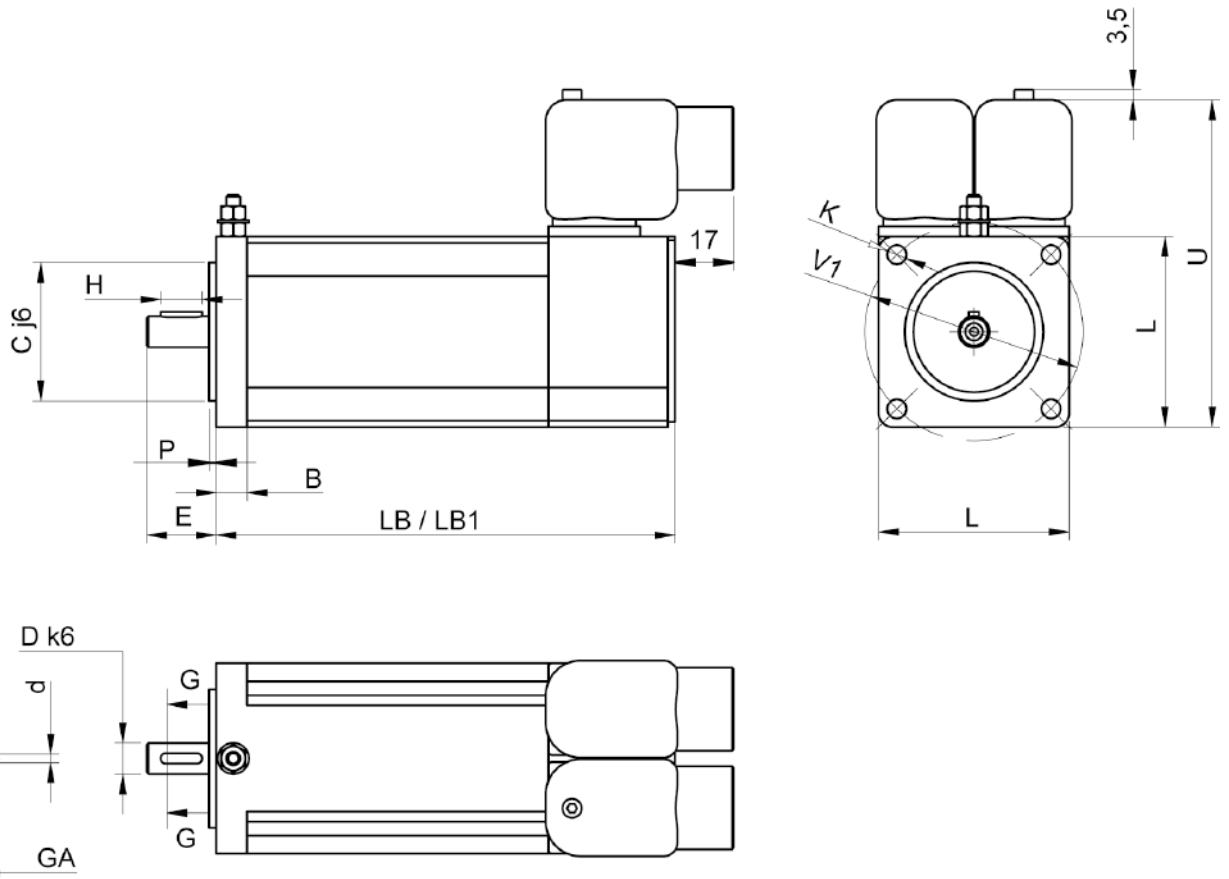

BPX	L	LB	LB1	C	P	B	V1	K	U	D	E	H	F	GA	d
	[mm]	[mm]	[mm]	[mm]	[mm]	[mm]	[mm]	[mm]	[mm]	[mm]	[mm]	[mm]	[mm]	[mm]	[mm]
0551	55	133	159	40	2	9	63	5.5	94.5	9	20	12	3	10.2	M3 x 9

# NUM Motors

## SHX & SPX Servomotors Outlines

### Servomotor Outlines

**shx**  
**spx**

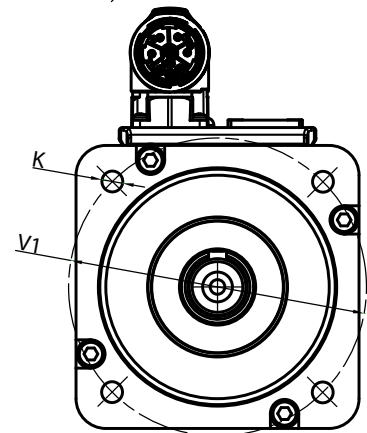
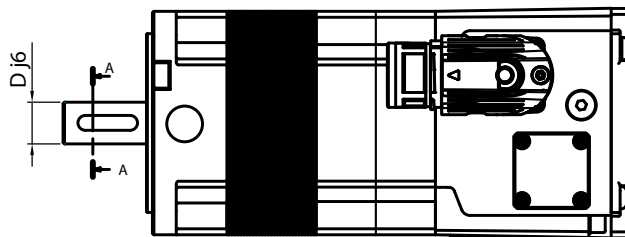
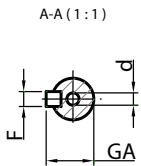
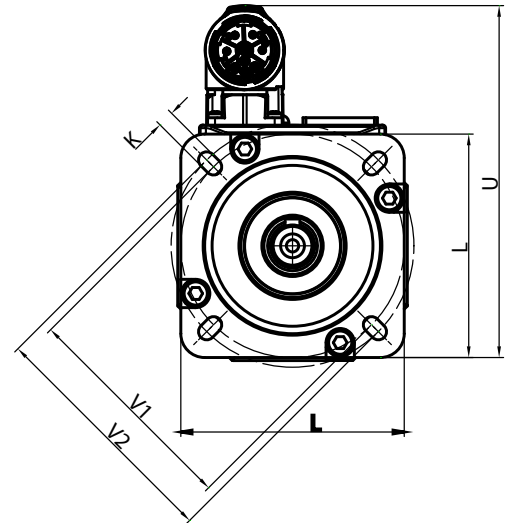
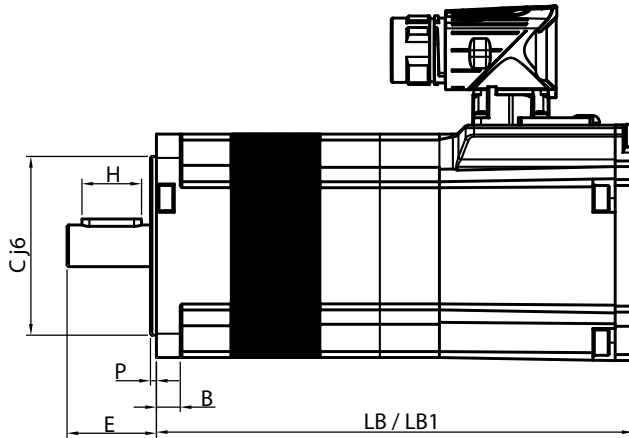

6

SHX SPX	L	LB*	LB1*	C	P	B	V1	V2	K	U	D	E	H	F	GA	d
	[mm]	[mm]	[mm]	[mm]	[mm]	[mm]	[mm]	[mm]	[mm]	[mm]	[mm]	[mm]	[mm]	[mm]	[mm]	[mm]
0751..	75	140	160	60	2.5	8	75	81.5	5.5	119.5	14	30	20	5	16	M5x10
0752..		170	190													
0951..	95	153	183	80	3	10	100	---	7	140.5	19	40	30	6	21.5	M6x16
0952..		183	213													
1261..	126	149	194	110	3.5	11	130	---	9	175	24	50	40	8	27	M8x19
1262..		179	224													
1263..		209	254													
1552..	155	192	235	130	3.5	13	165	---	11	200	32	58	45	10	35	M12x28
1554..		242	285													

\* LB without brake, LB1 with brake or high inertia version

### BPH Servomotor General Characteristics

BPH servomotors are compact medium inertia units, designed for the feeding axes of high-end machine tools, grinding machines, robotics and special machines. They are available in 75 mm, 95 mm, 115 mm, 142 mm and 190 mm frame sizes, with a variety of options.

General Motor Features	As per EN60034-1
Environment Storage Conditions	
- Temperature Range	-20 to +80 °C
- Relative Humidity	max. 80% without condensation
Environment Working Conditions	
- Temperature Range	0 to 40 °C without derating, max. 55 °C with derating
- Altitude	0 to 1000 m without derating, max. 3000 m with derating
Continuous Stall Torque Range	From 1.3 to 100 Nm
Degree of protection as per EN60529	IP65 IP67 as option
Connection	By 90° connector
Permanent Magnet Holding Brake	24 Vdc available as option
Motor Transducer	High resolution single turn and multi turn optical encoder Medium resolution single turn and multi turn optical encoder
Mounting Restriction	No mounting restrictions, IMB5 - IMV1 - IMV3 as per EN60034-7
Finishing	Black

# NUM Motors

## BPH Servomotors Technical Characteristics

### BPH Servomotor Technical Characteristics

For peak torque figures please refer to chapter 7 where the drive-motor associations are described.

BPH	Low Speed Cont. Torque	Rated Speed	Rotor Inertia		Motor Weight		Brake		Low Speed Cont. Current	Dimensioning Power
			Without Brake	With Brake	Without Brake	With Brake	Torque	Current		
	[Nm]	[rpm]	[g.m <sup>2</sup> ]	[g.m <sup>2</sup> ]	[kg]	[kg]	[Nm]	[A]	[Arms]	[kW]
0751N5...	1.3	3 000	0.08	0.12	3.5	3.85	2.5	0.5	2.2	0.41
0751V5...		6 000								
0752N5...	2.3	3 000	0.12	0.16	4.3	4.65	5	0.7	2.7	0.72
0752V5...		6 000								
0754N5...	4	3 000	0.21	0.25	6	6.35	11	0.8	3.5	1.26
0952N5...	4.3	3 000	0.3	0.41	6.7	7.5			0.7	3.5
0952V5...		6 000					5.9	2.70		
0953N5...	6	3 000	0.41	0.52	8	8.8	12	0.8	5.2	1.88
0953V5...		6 000							10.3	3.77
0955N5...	9.2	3 000	0.64	0.75	10.5	11.3	22	1	5.8	2.89
1152N5...	7.4	3 000	0.7	1.07	9.6	10.9			12	0.8
1152V5...		6 000					10.5	4.65		
1153K5...	10.5	2 000	0.97	1.34	11.7	13	20	1.5	5.3	2.20
1153N5...		3 000							9.2	3.30
1153V5...		6 000							12.6	6.60
1154K5...	13.3	2 000	1.25	1.62	13.8	15.1	40	80	6.2	2.79
1154N5...		3 000							10.1	4.18
1154V5...		6 000							17.6	8.36
1156N5...	18.7	3 000	1.8	2.17	17.9	19.2	40	1.5	12	5.87
1422K5...	12	2 000	1.59	2.54	17.2	19.4			20	1
1422N5...		3 000					10.4	3.77		
1422R5...		4 250					11.5	5.34		
1423K5...	17	2 000	2.19	3.14	20.1	22.3	40	1.5	9.5	3.56
1423N5...		3 000							11.7	5.34
1423R5...		4 250							16.9	7.57
1424K5...	22	2 000	2.79	3.74	23	25.2	40	1.5	10.4	4.61
1424N5...		3 000							15.6	6.91
1424R5...		4 250							20.8	9.79
1427N5...	35	3 000	4.29	5.24	31.7	33.9	40	1.5	24.2	11.00
1902K5...	25	2 000	5.14	8.25	32.1	36.2			20	1
1902N5...		3 000					19.9	7.85		
1902R5...		4 250					29.2	11.13		
1903K5...	36	2 000	7.1	10.2	37.3	41.4	40	1.5	19.7	7.54
1903N5...		3 000							27.8	11.31
1904K5...	46	2 000	9.04	12.1	42.4	46.5	40	1.5	20.6	9.63
1904N5...		3 000							30.3	14.45
1905H5...	56	1 500	11	14.1	47.6	51.7	80	1.5	20	8.80
1905L5...		2 500							31.4	14.66
1907K5...	75	2 000	14.9	18	58	62.1	80	1.5	27.9	15.71
1907N5...		3 000							52.3	23.56
190AK5...	100	2 000	20.75	23.8	73.9	78	80	1.5	44	20.94

# NUM Motors

## BPH Servomotors Ordering Codes

### BPH Servomotor Ordering Codes

	<b>BPH</b>	<b>075</b>	<b>1</b>	<b>N</b>	<b>5</b>	<b>Q</b>	<b>A</b>	<b>2</b>	<b>L</b>	<b>0</b>	<b>1</b>
<b>Series</b>											
<b>Size</b> (075, 095, 115, 142, 190)											
<b>Length</b>											
<b>Winding type</b>											
<b>Fixed value</b>					5						
<b>Sensor type</b>											
- High resolution multi-turn encoder						P					
- High resolution single-turn encoder						Q					
- Medium resolution multi-turn encoder						J					
- Medium resolution single-turn encoder						K					
<b>Brake</b>											
- Without brake							A				
- With brake							F				
<b>Fixed value</b>								2			
<b>Shaft extension</b>											
- Smooth									L		
- Keyed									C		
<b>Fixed value</b>										0	
<b>Degree of protection (shaft extension/frame)</b>											
- IP 65/65											1
- IP 67/67 option											2

### BPH Servomotor Outlines

See page 163 for BPH & BPG servomotor outlines.

### BPG Servomotor General Characteristics

BPG servomotors are compact very high inertia units, designed for the feeding axes of high-end machine tools, grinding machines, robotics and special machines. They are available in 75 mm, 95 mm, 115 mm, 142 mm and 190 mm frame sizes, with a variety of options.

General Motor Features	As per EN60034-1
Environment Storage Conditions	
- Temperature Range	-20 to +80 °C
- Relative Humidity	max. 80% without condensation
Environment Working Conditions	
- Temperature Range	0 to 40 °C without derating, max. 55 °C with derating
- Altitude	0 to 1000 m without derating, max. 3000 m with derating
Continuous Stall Torque Range	From 1.3 to 56 Nm
Degree of protection as per EN60529	IP65 IP67 as option
Connection	By 90° connector
Permanent Magnet Holding Brake	Not available
Motor Transducer	High resolution single turn and multi turn optical encoder Medium resolution single turn and multi turn optical encoder
Mounting Restriction	No mounting restrictions, IMB5 - IMV1 - IMV3 as per EN60034-7
Finishing	Black

### BPG Servomotor Technical Characteristics

For peak torque figures please refer to chapter 7 where the drive-motor associations are described.

BPG	Low Speed Cont. Torque	Rated Speed	Rotor Inertia		Motor Weight		Brake		Low Speed Cont. Current	Dimensioning Power
			Without Brake	With Brake	Without Brake	With Brake	Torque	Current		
			[g.m <sup>2</sup> ]	[g.m <sup>2</sup> ]	[kg]	[kg]	[Nm]	[A]		
0751N5...	1.3	3 000	0.25		4				2.2	0.41
0752N5...	2.3	3 000	0.3		4.8				2.7	0.72
0952N5...	4.3	3 000	0.86		7.6				3.5	1.35
0953N5...	6	3 000	0.97		8.9				5.2	1.88
1152N5...	7.4	3 000	2.45		11.2				5.5	2.32
1153K5...	10.5	2 000	2.73		13.3				5.3	2.20
1153N5...		3 000							9.2	3.30
1153V5...		6 000							12.6	6.60
1422N5...	12	3 000	6.7		20.4				10.4	3.77
1423N5...	17	3 000	7.3		23.3				11.7	5.34
1424K5...	22	2 000	7.9		26.2				10.4	4.61
1424R5...		4 250							20.8	9.79
1427N5...	35	3 000	9.7		34.9				24.2	11.00
1902K5...	25	2 000	20.9		38.1				16.6	5.24
1902N5...		3 000							19.9	7.85
1903K5...	36	2 000	22.9		43.3				19.7	7.54
1903N5...		3 000							27.8	11.31
1904N5...	46	3 000	24.8		48.6				30.3	14.45
1905L5...	56	2 500	26.8		53.6				31.4	14.66

# NUM Motors

## BPG Servomotors Ordering Codes

### BPG Servomotor Ordering Codes

	<b>BPG</b>	<b>075</b>	<b>1</b>	<b>N</b>	<b>5</b>	<b>Q</b>	<b>A</b>	<b>2</b>	<b>L</b>	<b>0</b>	<b>1</b>
<b>Series</b>											
<b>Size</b> (075, 095, 115, 142, 190)											
<b>Length</b>											
<b>Winding type</b>											
<b>Fixed value</b>					5						
<b>Sensor type</b>											
- High resolution multi-turn encoder						P					
- High resolution single-turn encoder						Q					
- Medium resolution multi-turn encoder						J					
- Medium resolution single-turn encoder						K					
<b>Brake</b>											
- Brake not available							A				
<b>Fixed value</b>								2			
<b>Shaft extension</b>											
- Smooth									L		
- Keyed									C		
<b>Fixed value</b>										0	
<b>Degree of protection (shaft extension/frame)</b>											
- IP 65/65											1
- IP 67/67 option											2

# NUM Motors

## BPH & BPG Servomotors Outlines

### BPH & BPG Servomotor Outlines

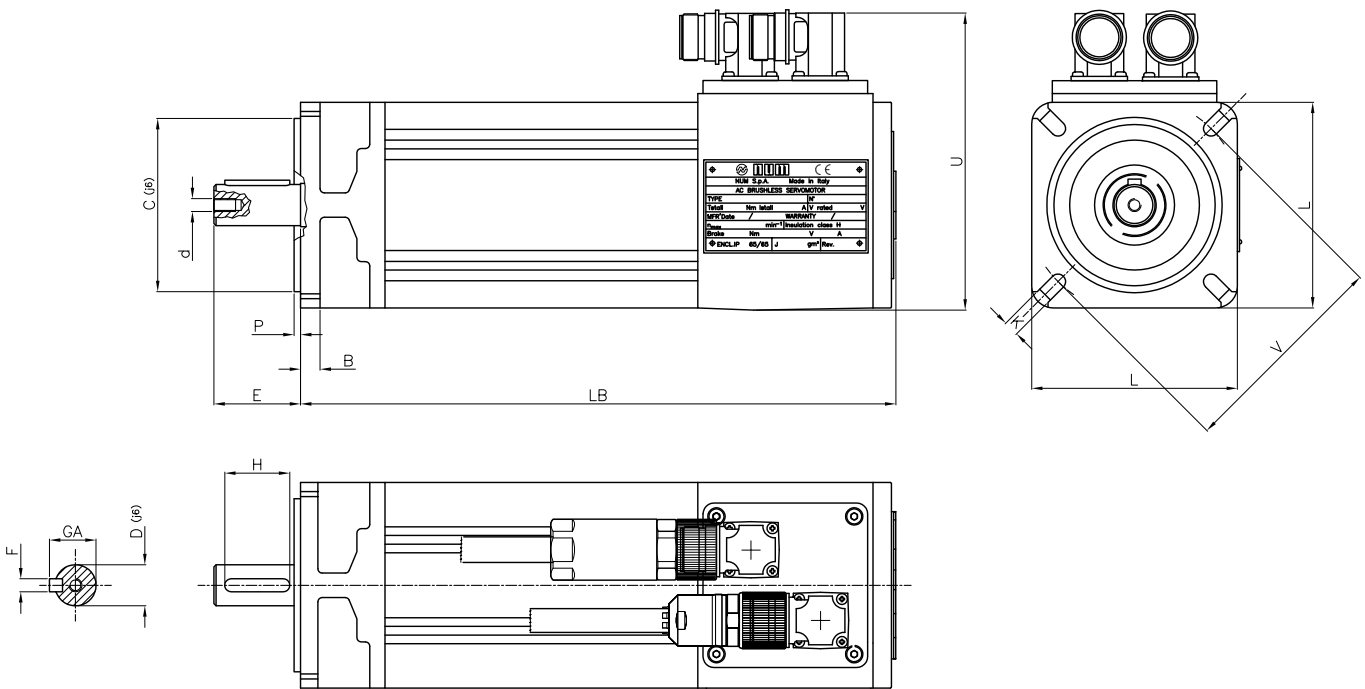

6

BPH BPG									BPH Shaft					BPG Shaft											
	L	LB***	C	P	B	V	K	U	D	E	H	F	GA	d	D	E	H	F	GA	d					
	[mm]	[mm]	[mm]	[mm]	[mm]	[mm]	[mm]	[mm]	[mm]	[mm]	[mm]	[mm]	[mm]	[mm]	[mm]	[mm]	[mm]	[mm]	[mm]	[mm]					
0751..	75	221	60	2.5	8	75	6	117	11	23	15	4	12.5	M4x10	14	30	20	5	16	M5x12					
0752..		250							14	30	20	5	16	M5x12											
0754..		308																							
0952..	95	275	80	3	9	100	7	137	19	40	30	6	21.5	M6x16	19	40	30	6	21.5	M6x16					
0953..		304																							
0955..		362																							
1152..	115	290	95	3	10	115	9	166	19	40	30	6	21.5	M6x16	24	50	40	8	27	M8x19					
1153..		319																							
1154..		348												24							50	40	8	27	M8x19
1156..		406																							
1422..	142	316	130	3	14	165	11	193	24	50	40	8	27	M8x19	32	58	46	10	35	M12x28					
1423..		345																							
1424..		374																							
1427..		461												32							58	45	10	35	M12x28
1902..	190	355	180	3	17	215	14	242*	32	58	45	10	35	M12x28	38	80	70	10	41	M12x28					
1903..		384																							
1904..		413																							
1905..		442																							
1907..		500												38							80	70	10	41	M12x28
190A..		605																							

\* 190 2K. 2N. 3K. 4K. 5H

\*\* 190 2R. 3N. 4N. 5L. 7K. AK

\*\*\* BPH length doesn't change with or without brake

### BHL Servomotor General Characteristics

BHL servomotors are very compact high inertia units, designed for the feeding axes of large machine tools. They are available in one, 260 mm, frame size, with a variety of options.

General Motor Features	As per EN60034-1
Environment Storage Conditions	
- Temperature Range	-20 to +80 °C
- Relative Humidity	max. 80% without condensation
Environment Working Conditions	
- Temperature Range	0 to 40 °C without derating, max. 55 °C with derating
- Altitude	0 to 1000 m without derating, max. 3000 m with derating
Continuous Stall Torque Range	From 85 to 160 Nm
Degree of Protection as per EN60529	Housing IP65, shaft and fan IP54
Connection	Fanless version: connector Fan cooled version: terminal board
Permanent Magnet Holding Brake	24 Vdc available as option
Motor Transducer	High resolution single turn and multi turn optical encoder
Mounting Restriction	No mounting restrictions, IMB5 - IMV1 - IMV3 as per EN60034-7
Finishing	Black

### BHL Servomotor Technical Characteristics

For peak torque figures please refer to chapter 7 where the drive-motor associations are described.

BHL	Low Speed Cont. Torque	Rated Speed	Rotor Inertia		Motor Weight		Brake		Low Speed Cont. Current	Dimensioning Power
			Without Brake	With Brake	Without Brake	With Brake	Torque	Current		
			[Nm]	[rpm]	[g.m <sup>2</sup> ]	[g.m <sup>2</sup> ]	[kg]	[kg]		
2601N5...	85	3 000	45	48.1	95	99	80	1.5	52	26.70
2601N1...*	120				100	104			75	37.70
2602K5...	120	2 000	66.2	69.3	126	130			52	25.13
2602K1...*	160				131	135			69.3	33.51

\* BHL motors with forced convection (V) require an auto-transformer for 480Vac network (code: AMOTRF001)

# NUM Motors

## BHL Servomotors Ordering Codes

### BHL Servomotor Ordering Codes

	<b>BHL</b>	<b>260</b>	<b>1</b>	<b>N</b>	<b>1</b>	<b>Q</b>	<b>A</b>	<b>2</b>	<b>L</b>	<b>0</b>	<b>5</b>
<b>Series</b>											
<b>Size</b>											
<b>Length</b>											
<b>Winding type</b>											
<b>Power connection</b>											
- With terminal box mandatory for forced convection version						1					
- With power connector mandatory for natural convection version						5					
<b>Sensor type</b>											
- High resolution multi-turn encoder							P				
- High resolution single-turn encoder							Q				
<b>Brake</b>											
- Without brake								A			
- With brake								F			
<b>Cooling</b>											
- Natural convection									2		
- With fan (ventilated)									V		
<b>Shaft extension</b>											
- Smooth										L	
- Keyed										C	
<b>Fixed value</b>											0
<b>Degree of protection (shaft extension/frame/fan if present)</b>											
- IP 54/65/54											5

6

# NUM Motors

## BHL Servomotors Outlines

### BHL Servomotor Outlines

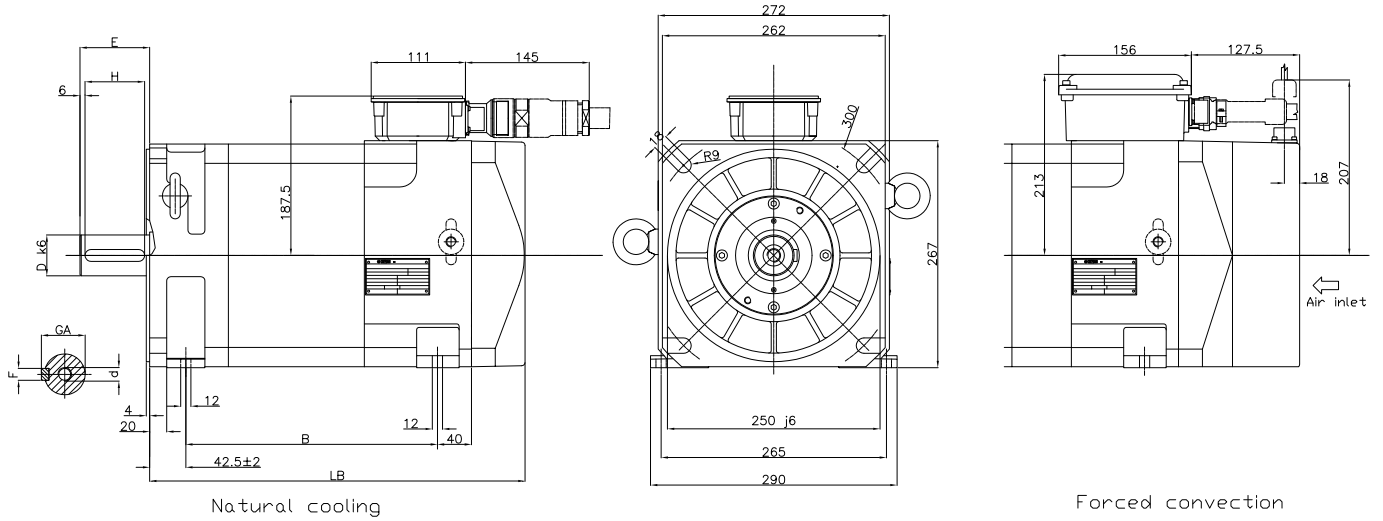

BHL	LB	B	D	E	H	F	GA	d
	[mm]	[mm]	[mm]	[mm]	[mm]	[mm]	[mm]	[mm]
2601x5xx2...	440	296 ± 2	48	82 ± 1	70	14	51.5	M16x36
2601x1xxV...	521	296 ± 2	48	82 ± 1	70	14	51.5	M16x36
2602x5xx2...	510	366 ± 2	48	82 ± 1	70	14	51.5	M16x36
2602x1xxV...	591	366 ± 2	48	82 ± 1	70	14	51.5	M16x36

### AMS & IM Spindlemotors General Characteristics

AMS asynchronous spindle motors incorporate a high resolution encoder and are capable of fast and accurate positioning, making them ideal for C axis control as well as spindle indexing applications. The motors are compact, have a low rotor inertia, and feature a built-in axial fan.

By using the flux vector control capabilities of NUMDrive modules, AMS spindle motors ensure very smooth rotation, even at low speeds.

Special versions of AMS spindle motors (size 132 and 160) are available for applications involving very high radial loads.

General Motor Features	As per EN60034-1
Environment Storage Conditions	
- Temperature Range	-20 to +80 °C
- Relative Humidity	max. 80% without condensation
Environment Working Conditions	
- Temperature Range	0 to 40 °C without derating, max. 55 °C with derating
- Altitude	0 to 1000 m without derating, max. 3000 m with derating
Rated Power	From 3.7 up to 55 kW
Degree of Protection as per EN60529	IP65 for the housing IP54 for the fan IP54 for the shaft, optionally IP65
Connection	By terminal board for the power By connector for the encoder
Motor Transducer	High resolution single turn and multi turn optical encoder
Mounting Restriction	No mounting restrictions, IMB5 - IMV1 - IMV3 as per EN60034-7
Vibration Class as per EN60034-14	R class, optionally S class
Fan Input Voltage	400 Vac ± 5% 3 phases, 50/60 Hz (AMS motors) 220 Vac ± 5% 1 phase, 50/60 Hz (IM motors)

# NUM Motors

## AMS & IM Spindle Motors Technical Characteristics

### AMS & IM Spindlemotors Technical Characteristics

For peak torque figures please refer to chapter 7 where the drive-motor associations are described.

AMS	Connection Type	Rated Continuous Power	Rated Speed	Max Speed	Rated Torque	Rated Continuous Current	Rotor Inertia	Fan (3 Phases)		Motor Weight	
								Voltage	Current		
								[kW]	[rpm]		[rpm]
100SB1...	Y	3.7	1500	6500	24	20	9	400	0.11	37	
100MB1...	Y	5.5			35	26	14			49	
100GB1...	Y	9			57	39	23			71	
100SD1...	Y	3.7			12000	24	20			9	37
100MD1...	Y	5.5				35	26			14	49
100GD1...	Y	9				57	39			23	71
132SA1...	Y	5	750	7000	64	26	55	0.2	105		
132SC1...	Y	10	1500		64	39					
132SE1...	Δ	15	1750		82	52					
132MA1...	Y	7.5	750		95	39	75			131	
132MC1...	Y	15	1500		95	52					
132ME1...	Δ	19.5	2000		100	72					
132LA1...	Y	11	750	10000	140	52	113	0.3	183		
132LE1...	Y	22	1250		168	72					
132SF1...	Y	5	750		64	26	55			105	
132SG1...	Y	10	1500		64	39					
132SH1...	Δ	15	1750		82	52					
132MF1...	Y	7.5	750		95	39	75			131	
132MG1...	Y	15	1500	95	52						
132MH1...	Δ	19.5	2000	100	72						
132LF1...	Y	11	750	9000	140	52	113	0.3	183		
132LI1...	Y	12.5	680		175	39					
132LH1...	Y	22	1250		168	72					
160MA1...	Y	18	650	8500	264	52	250	0.3	215		
	Δ		1300		132						
160MB1...	Y	26	1200		208	72					
	Δ		2400		104						
160MC1...	Δ	36	1700		202	100					
160LA1...	Y	18	500		6500	344	52			370	0.3
	Δ		1000	172							
160LB1...	Y	26	950	260		72					
	Δ		1900	130							
160LC1...	Δ	36	1050	328		100					

IM	Connection Type	Rated Continuous Power	Rated Speed	Max Speed	Rated Torque	Rated Continuous Current	Rotor Inertia	Fan (1 Phase)		Motor Weight
								Voltage	Current	
								[kW]	[rpm]	
18MK14...	YY	55	1050	7500	500	145	570	230	0.8	415

# NUM Motors

AMS & IM Spindle Motors  
AMS Ordering Codes

## AMS Spindle Motor Ordering Codes

	AMS	100	S	B	1	Q	22	L	R	0
<b>Series</b>										
<b>Size</b> (100, 132, 160)										
<b>Length</b>										
<b>Winding type</b>										
<b>Fixed value</b>					1					
<b>Sensor type</b>										
- High resolution multi-turn encoder						P				
- High resolution single-turn encoder						Q				
<b>Fixed value</b>							22			
<b>Shaft extension</b>										
- Smooth								L		
- Keyed								C		
<b>Vibration class</b>										
- Class R									R	
- Class S									S	
<b>Degree of protection (shaft extension/frame/fan) and radial load</b>										
- IP 54/65/54 with standard permissible radial load										0
- IP 65/65/54 with standard permissible radial load										1
- IP 54/65/54 with high permissible radial load (just for size 132 and 160)										2
- IP 65/65/54 with high permissible radial load (just for size 132 and 160)										3

6

# NUM Motors

AMS & IM Spindle Motors  
IM Ordering Codes

## IM Spindle Motor Ordering Codes

	IM	18	M	K14	C	Q	22	L	R	0
<b>Series</b>										
<b>Size</b>										
<b>Length</b>										
<b>Winding type</b>										
<b>Fixed value</b>					C					
<b>Sensor type</b>										
- High resolution multi-turn encoder						P				
- High resolution single-turn encoder						Q				
<b>Fixed value</b>							22			
<b>Shaft extension</b>										
- Smooth								L		
- Keyed								C		
<b>Vibration class</b>										
- Class R									R	
- Class S									S	
<b>Degree of protection (shaft extension)</b>										
- IP 54										0
- IP 65										1

# NUM Motors

## AMS & IM Spindle Motors Outlines

### AMS Spindle Motor Outlines

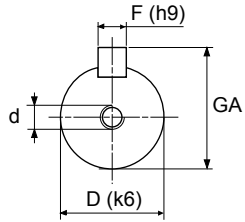

	Shaft							
	LB	B	D	E	W	F	GA	d
	mm	mm	mm	mm	mm	mm	mm	mm
100 S	388	179 ± 1.5	32	60	50	10	35	M12x30
100 M	442	233 ± 1.5						
100 G	535	326 ± 1.5	38	80	70		41	
132 S	521	296 ± 2	42	110	90	12	45	M16x36
132 M	591	366 ± 2						
132 L	721	496 ± 2	48	110	90	14	51.5	

AMS 100 Motor

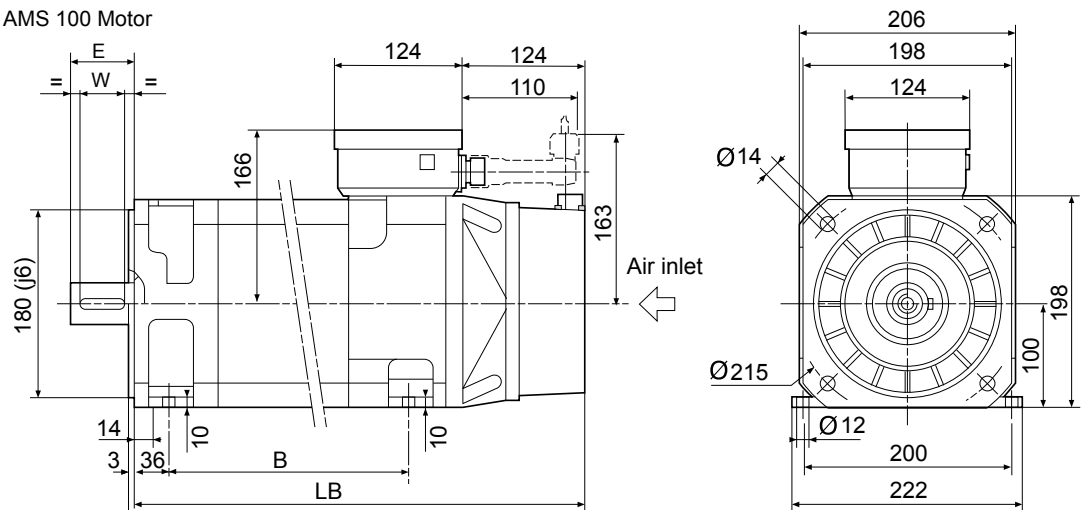

AMS 132 Motor

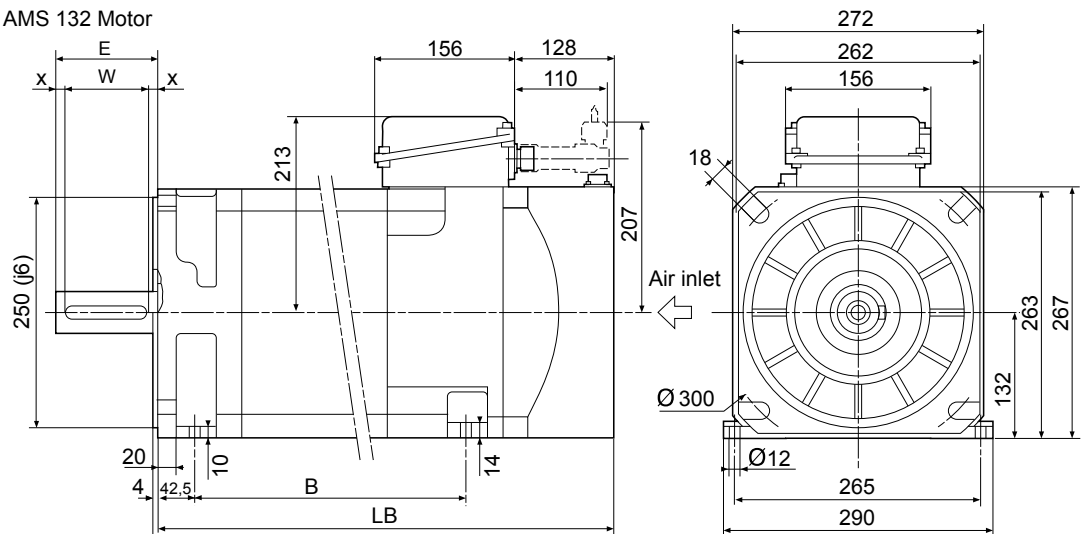

All dimensions in mm

# NUM Motors

## AMS & IM Spindle Motors Outlines

### AMS Spindle Motor Outlines

#### AMS 160 Motor

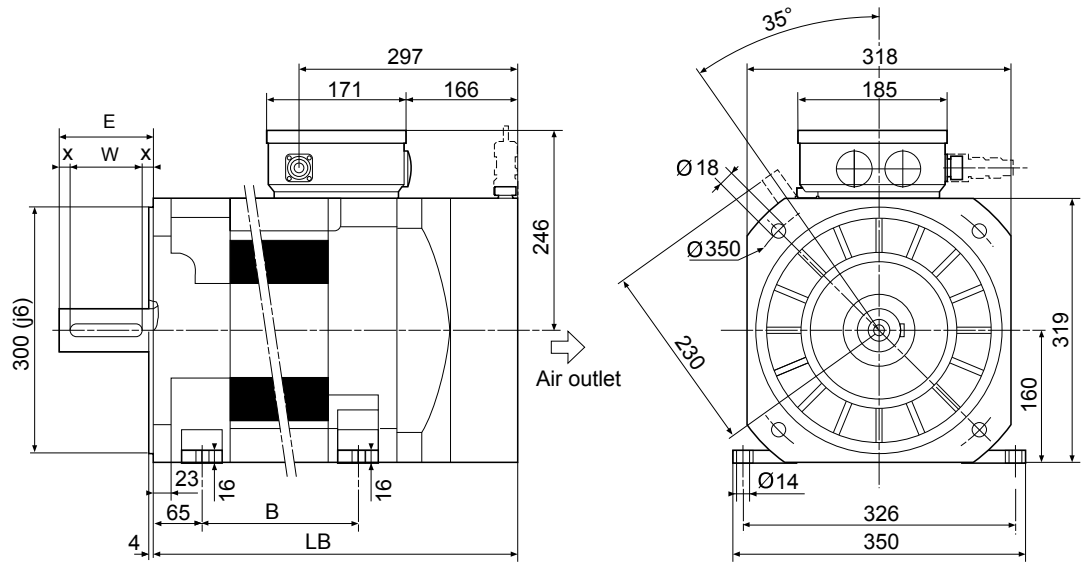

	Shaft							
	LB	B	D	E	W	F	GA	d
	mm	mm	mm	mm	mm	mm	mm	mm
160 M	682	385 ± 2	55	110	90	16	59	M20x42
160 L	827	530 ± 2						

### IM Spindle Motor Outlines

#### IM 18MK14 Motor

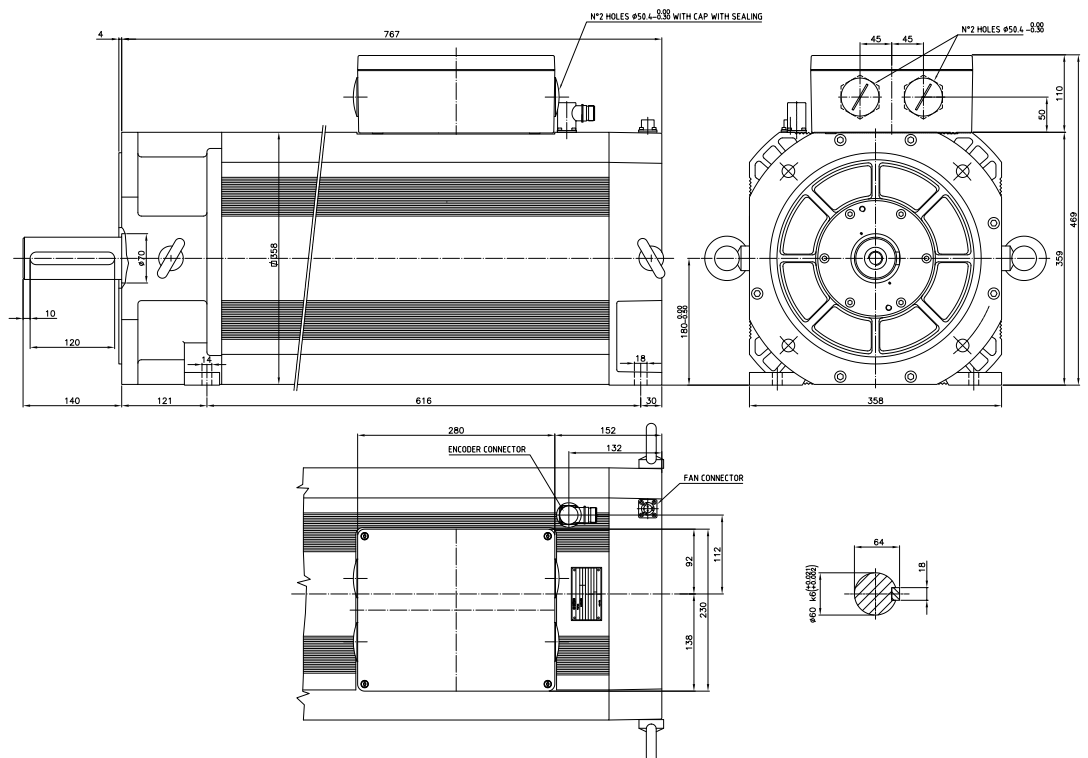

All dimensions in mm



### Encoder Characteristics

All NUM motors are equipped with an encoder to provide feedback on the angular position of the rotor for phase switching. The position information is also used to close the controller's position and speed control loops.

Users can choose the type of encoder to suit their application needs, subject to the type of motor and functional safety requirements, as shown in the table below:

Sin/Cos Encoders	Technical Characteristics			
	Encoder P	Encoder Q	Encoder J	Encoder K
Sensor Type	High Resolution Multi-Turn	High Resolution Single-Turn	Medium Resolution Multi-Turn	Medium Resolution Single-Turn
Precision	< ±45 arcseconds		< ±80 arcseconds	
Operating Temperature Range	-40°C / +125°C			
Supply Voltage	7V - 12V			
Resolution per Turn	1024	1024	128	128
Turns	4096	1	4096	1
Electrical Interface	1Vpp SinCos + Hiperface			

Encoders for Single Cable Motor (SHX/SPX)	Technical Characteristics			
	Encoder I	Encoder L	Encoder 3	Encoder 4
Sensor Type	Medium Resolution Multi-Turn	Medium Resolution Single-Tturn	Medium Resolution Multi-Turn	Medium Resolution Single-Turn
Precision	< ±60 arcseconds			
Operating Temperature Range	-40°C / +125°C			
Supply Voltage	7V - 12V			
Measurement Step per Revolution	1048576	1048576	1048576	1048576
Turns	4096	1	4096	1
Electrical Interface	Fast serial 2-wire protocol			
Functional Safety	no		SIL 2, PL d	
Other Info	Motor thermal probe information integrated in the encoder protocol (no need of cabling)			

### NUM Custom Motors

As well as the standard motors described on preceding pages, NUM designs and manufactures special motors and built-in (Motorspindle) motors to suit customers' specific needs.

For information about special or built-in motors, please contact your local NUM sales office.



Motorspindle®: stator elements, synchronous and asynchronous technology, for integration in electro spindles.



# Motor/Drive Associations

## Table of Contents

	Page
<b>Servo Motors</b>	<b>177</b>
Association of BHX & SHX Motors with NUMDrive X	177
Association of BPX & SPX Motors with NUMDrive X	178
Association of BPH Motors with NUMDrive X	179
Association of BPG Motors with NUMDrive X	181
Association of BHL Motors with NUMDrive X	183
<b>Spindle Motors</b>	<b>184</b>
General Description	184
Association of AMS and IM Spindle Motors with NUMDrive X	185



# Motor/Drive Associations

Servo Motors  
Association of BHX & SHX Motors with NUMDrive X

## Association of BHX & SHX Motors with NUMDrive X (Switching Frequency 10 kHz)

BHX SHX	MDLUX....		007B	007A	014B	014A	021B	021A	034A	050B	050A	075A	130A	200A	400A
	Rated speed	Low speed cont. torque	Peak torque	Peak torque	Peak torque	Peak torque	Peak torque	Peak torque	Peak torque	Peak torque	Peak torque	Peak torque	Peak torque	Peak torque	Peak torque
	[rpm]	[Nm]	[Nm]	[Nm]	[Nm]	[Nm]	[Nm]	[Nm]	[Nm]	[Nm]	[Nm]	[Nm]	[Nm]	[Nm]	[Nm]
0751V5...	6 000	1.2			4.3	4.3									
0752V5...	6 000	2.1			6.6	6.6	7.8	7.8							
0951V5...	6 000	2.4			6.4	6.4	7.5	7.5							
0952N5...	3 000	4.3			13.2	13.2	14.5	14.5							
0952V5...	6 000					7.8		10.5	14.5						
1261N5...	3 000	4.5			11.5	11.5	13	13							
1261V5...	6 000							9.5	12.4						
1262N5...	3 000	8.4				13.8		20	27						
1262V5...	6 000									22	22	27			
1263R5...	4 500	11								34	34				
1552N5...	3 000	12						23	33	39	39				
1552R5...	4 500	12								35	35				
1554N5...	3 000	20								53	53	72			

## Association of BHX & SHX Motors with NUMDrive X (Switching Frequency 5 kHz)

BHX SHX	MDLUX....		007B	007A	014B	014A	021B	021A	034A	050B	050A	075A	130A	200A	400A
	Rated speed	Low speed cont. torque	Peak torque	Peak torque	Peak torque	Peak torque	Peak torque	Peak torque	Peak torque	Peak torque	Peak torque	Peak torque	Peak torque	Peak torque	Peak torque
	[rpm]	[Nm]	[Nm]	[Nm]	[Nm]	[Nm]	[Nm]	[Nm]	[Nm]	[Nm]	[Nm]	[Nm]	[Nm]	[Nm]	[Nm]
0751V5...	6 000	1.2			4.3	4.3	4.3			4.3					
0752V5...	6 000	2.1			6.6	6.6	7.8	7.8		7.8					
0951V5...	6 000	2.4			6.4	6.4	7.5	7.5		7.5					
0952N5...	3 000	4.3			13.2	13.2	14.5	14.5		14.5					
0952V5...	6 000				7.8	7.8	10.5	10.5	14.5	14.5					
1261N5...	3 000	4.5			11.5	11.5	13	13		13					
1261V5...	6 000				7	7	9.5	9.5	12.4	12.4					
1262N5...	3 000	8.4			13.8	13.8	20	20	27	27					
1262V5...	6 000								16	22	22	27			
1263R5...	4 500	11						16.5	25	34	34				
1552N5...	3 000	12				16		23	33	39	39				
1552R5...	4 500	12						17	26.5	35	35				
1554N5...	3 000	20						24	38	53	53	72			

# Motor/Drive Associations

Servo Motors

Association of BPX & SPX Motors with NUMDrive X

## Association of BPX & SPX Motors with NUMDrive X (Switching Frequency 10 kHz)

BPX SPX	MDLUX....		007B	007A	014B	014A	021B	021A	034A	050B	050A	075A	130A	200A	400A
	Rated speed	Low speed cont. torque	Peak torque	Peak torque	Peak torque	Peak torque	Peak torque	Peak torque	Peak torque	Peak torque	Peak torque	Peak torque	Peak torque	Peak torque	Peak torque
	[rpm]	[Nm]	[Nm]	[Nm]	[Nm]	[Nm]	[Nm]	[Nm]	[Nm]	[Nm]	[Nm]	[Nm]	[Nm]	[Nm]	[Nm]
0551V5...	6 000	0.5	1.5	1.5	1.5	1.5									
0751V5...	6 000	1.4			4.3	4.3									
0752V5...	6 000	2.3			6.6	6.6	7.8	7.8							
0951V5...	6 000	2.7			6.4	6.4	7.5	7.5							
0952N5...	3 000	5			13.2	13.2	14.5	14.5							
0952V5...	6 000					7.8		10.5	14.5						
1261N5...	3 000	5.2			11.5	11.5	13	13							
1261V5...	6 000							9.5	12.4						
1262N5...	3 000	9.8				13.8		20	27						
1262V5...	6 000									22	22	27			
1263R5...	4 500	12.6								34	34				
1552N...	3 000	13.8								39	39				
		12.7						23	33						
1552R...	4 500	13.8								35	35				
1554N...	3 000	23								53	53	72			

## Association of BPX & SPX Motors with NUMDrive X (Switching Frequency 5 kHz)

BPX SPX	MDLUX....		007B	007A	014B	014A	021B	021A	034A	050B	050A	075A	130A	200A	400A
	Rated speed	Low speed cont. torque	Peak torque	Peak torque	Peak torque	Peak torque	Peak torque	Peak torque	Peak torque	Peak torque	Peak torque	Peak torque	Peak torque	Peak torque	Peak torque
	[rpm]	[Nm]	[Nm]	[Nm]	[Nm]	[Nm]	[Nm]	[Nm]	[Nm]	[Nm]	[Nm]	[Nm]	[Nm]	[Nm]	[Nm]
0551V5...	6 000	0.5	1.5	1.5	1.5	1.5	1.5								
0751V5...	6 000	1.4			4.3	4.3	4.3			4.3					
0752V5...	6 000	2.3			6.6	6.6	7.8	7.8		7.8					
0951V5...	6 000	2.7			6.4	6.4	7.5	7.5		7.5					
0952N5...	3 000	5			13.2	13.2	14.5	14.5		14.5					
0952V5...	6 000					7.8	7.8	10.5	10.5	14.5	14.5				
1261N5...	3 000	5.2			11.5	11.5	13	13		13					
1261V5...	6 000					7	7	9.5	9.5	12.4	12.4				
1262N5...	3 000	9.8			13.8	13.8	20	20	27	27					
1262V5...	6 000										22	22	27		
1262V5...		9.1							16						
1263R5...	4 500	12.6						16.5	25	34	34				
1552N5...	3 000	13.8				16		23	33	39	39				
1552R5...	4 500	13.8						17	26.5	35	35				
1554N5...	3 000	23								53	53	72			
		21						24	38						

# Motor/Drive Associations

Servo Motors

Association of BPH Motors with NUMDrive X

## Association of BPH Motors with NUMDrive X (Switching Frequency 10 kHz)

BPH	MDLUX....		014B	014A	021B	021A	034A	050B	050A	075A	130A	200A	400A
	Rated speed	Low speed cont. torque	Peak torque	Peak torque	Peak torque	Peak torque	Peak torque	Peak torque	Peak torque	Peak torque	Peak torque	Peak torque	Peak torque
	[rpm]	[Nm]	[Nm]	[Nm]	[Nm]	[Nm]	[Nm]	[Nm]	[Nm]	[Nm]	[Nm]	[Nm]	[Nm]
0751N5...	3 000	1.3	5.2	5.2									
0751V5...	6 000		3.9	3.9									
0752N5...	3 000	2.3	7.5	7.5									
0752V5...	6 000		5.9	5.9									
0754N5...	3 000	4	11	11									
0952N5...	3 000	4.3	11	11									
0952V5...	6 000					10							
0953N5...	3 000	6		11.2		16							
0953V5...	6 000							14	14				
0955N5...	3 000	9.2				22							
1152N5...	3 000	7.4		11.9		16							
1152V5...	6 000							14	14				
1153K5...	2 000	10.5		17.2		24							
1153N5...	3 000							22	22				
1153V5...	6 000							18	18				
1154K5...	2 000	13.3				27							
1154N5...	3 000							27	27				
1154V5...	6 000								23	23			
1156N5...	3 000	18.7						33	33				
1422K5...	2 000	12				22							
1422N5...	3 000							31	31				
1422R5...	4 250							19	19				
1423K5...	2 000	17						33	33				
1423N5...	3 000							28	28				
1423R5...	4 250								28	28			
1424K5...	2 000	22						41	41				
1424N5...	3 000								41	41			
1424R5...	4 250									45			
1427N5...	3 000	35									71		
1902K5...	2 000	25							40	40			
1902N5...	3 000									35			
1902R5...	4 250										36		
1903K5...	2 000	36								52			
1903N5...	3 000										54		
1904K5...	2 000	46								90			
1904N5...	3 000										92		
1905H5...	1 500	56								82			
1905L5...	2 500										79		
1907K5...	2 000	75									120		
1907N5...	3 000											125	
190AK5...	2 000	100										145	

# Motor/Drive Associations

Servo Motors  
Association of BPH Motors with NUMDrive X

## Association of BPH Motors with NUMDrive X (Switching Frequency 5 kHz)

BPH	MDLUX....		014B	014A	021B	021A	034A	050B	050A	075A	130A	200A	400A
	Rated speed	Low speed cont. torque	Peak torque	Peak torque	Peak torque	Peak torque	Peak torque	Peak torque	Peak torque	Peak torque	Peak torque	Peak torque	Peak torque
	[rpm]	[Nm]	[Nm]	[Nm]	[Nm]	[Nm]	[Nm]	[Nm]	[Nm]	[Nm]	[Nm]	[Nm]	[Nm]
0751N5...	3 000	1.3	5.2	5.2									
0751V5...	6 000		3.9	3.9									
0752N5...	3 000	2.3	7.5	7.5									
0752V5...	6 000		5.9	5.9									
0754N5...	3 000	4	11	11									
0952N5...	3 000	4.3	11	11									
0952V5...	6 000		7.2	7.2	10	10							
0953N5...	3 000	6	11.2	11.2	16	16							
0953V5...	6 000						14	14	14				
0955N5...	3 000	9.2	15.7	15.7	22	22							
1152N5...	3 000	7.4	11.9	11.9	16	16							
1152V5...	6 000						14	14	14				
1153K5...	2 000	10.5	17.2	17.2	24	24							
1153N5...	3 000						22	22	22				
1153V5...	6 000						18	18	18				
1154K5...	2 000	13.3	19.8	19.8	27	27							
1154N5...	3 000						27	27	27				
1154V5...	6 000							23	23	23			
1156N5...	3 000	18.7					33	33	33				
1422K5...	2 000	12	19.2	19.2	22	22							
1422N5...	3 000						20	31	31				
1422R5...	4 250						19	19	19				
1423K5...	2 000	17					33	33	33				
1423N5...	3 000						28	28	28				
1423R5...	4 250							28	28	28			
1424K5...	2 000	22					41	41	41				
1424N5...	3 000							41	41	41			
1424R5...	4 250									45			
1427N5...	3 000	35								71			
1902K5...	2 000	25						40	40	40			
1902N5...	3 000							35	35	35			
1902R5...	4 250									36			
1903K5...	2 000	36						52	52	52			
1903N5...	3 000									54			
1904K5...	2 000	46								90			
1904N5...	3 000									69			
1905H5...	1 500	56						82	82	82			
1905L5...	2 500									79			
1907K5...	2 000	75								120			
1907N5...	3 000										125		
190AK5...	2 000	100									145		

# Motor/Drive Associations

Servo Motors

Association of BPG Motors with NUMDrive X

## Association of BPG Motors with NUMDrive X (Switching Frequency 10 kHz)

BPG	MDLUX....		014B	014A	021B	021A	034A	050B	050A	075A	130A	200A	400A
	Rated speed	Low speed cont. torque	Peak torque	Peak torque	Peak torque	Peak torque	Peak torque	Peak torque	Peak torque	Peak torque	Peak torque	Peak torque	Peak torque
	[rpm]	[Nm]	[Nm]	[Nm]	[Nm]	[Nm]	[Nm]	[Nm]	[Nm]	[Nm]	[Nm]	[Nm]	[Nm]
0751N5...	3 000	1.3	5.2	5.2									
0752N5...	3 000	2.3	7.5	7.5									
0952N5...	3 000	4.3	11	11									
0953N5...	3 000	6		11.2		16							
1152N5...	3 000	7.4		11.9		16							
1153K5...	2 000	10.5		17.2		24							
1153N5...	3 000							22	22				
1153V5...	6 000							18	18				
1422N5...	3 000	12						31	31				
1423N5...	3 000	17						28	28				
1424K5...	2 000	22						41	41				
1424R5...	4 250									45			
1427N5...	3 000	35									71		
1902K5...	2 000	25							40	40			
1902N5...	3 000									35			
1903K5...	2 000	36								52			
1903N5...	3 000										54		
1904N5...	3 000	46									92		
1905L5...	2 500	56									79		

7

# Motor/Drive Associations

Servo Motors

Association of BPG Motors with NUMDrive X

## Association of BPG Motors with NUMDrive X (Switching Frequency 5 kHz)

BPG	MDLUX....		014B	014A	021B	021A	034A	050B	050A	075A	130A	200A	400A
	Rated speed	Low speed cont. torque	Peak torque	Peak torque	Peak torque	Peak torque	Peak torque	Peak torque	Peak torque	Peak torque	Peak torque	Peak torque	Peak torque
	[rpm]	[Nm]	[Nm]	[Nm]	[Nm]	[Nm]	[Nm]	[Nm]	[Nm]	[Nm]	[Nm]	[Nm]	[Nm]
0751N5...	3 000	1.3	5.2	5.2									
0752N5...	3 000	2.3	7.5	7.5									
0952N5...	3 000	4.3	11	11									
0953N5...	3 000	6	11.2	11.2	16	16							
1152N5...	3 000	7.4	11.9	11.9	16	16							
1153K5...	2 000	10.5	17.2	17.2	24	24							
1153N5...	3 000						22	22	22				
1153V5...	6 000						18	18	18				
1422N5...	3 000	12					20	31	31				
1423N5...	3 000	17					28	28	28				
1424K5...	2 000	22					41	41	41				
1424R5...	4 250									45			
1427N5...	3 000	35								71			
1902K5...	2 000	25						40	40	40			
1902N5...	3 000							35	35	35			
1903K5...	2 000	36						52	52	52			
1903N5...	3 000									54			
1904N5...	3 000	46								69			
1905L5...	2 500	56								79			

# Motor/Drive Associations

## Servo Motors

### Association of BHL Motors with NUMDrive X

#### Association of BHL Motors with NUMDrive X (Switching Frequency 10 kHz)

BHL	MDLUX....		014B	014A	021B	021A	034A	050B	050A	075A	130A	200A	400A
	Rated speed	Low speed cont. torque	Peak torque	Peak torque	Peak torque	Peak torque	Peak torque	Peak torque	Peak torque	Peak torque	Peak torque	Peak torque	Peak torque
	[rpm]	[Nm]	[Nm]	[Nm]	[Nm]	[Nm]	[Nm]	[Nm]	[Nm]	[Nm]	[Nm]	[Nm]	[Nm]
2601N5...	3 000	85										210	
2601N1...		112										210	
2602K5...	2 000	120										290	
2602K1...		160										290	

#### Association of BHL Motors with NUMDrive X (Switching Frequency 5 kHz)

BHL	MDLUX....		014B	014A	021B	021A	034A	050B	050A	075A	130A	200A	400A
	Rated speed	Low speed cont. torque	Peak torque	Peak torque	Peak torque	Peak torque	Peak torque	Peak torque	Peak torque	Peak torque	Peak torque	Peak torque	Peak torque
	[rpm]	[Nm]	[Nm]	[Nm]	[Nm]	[Nm]	[Nm]	[Nm]	[Nm]	[Nm]	[Nm]	[Nm]	[Nm]
2601N5...	3 000	85									145		
2601N1...		120										210	
2602K5...	2 000	120									205		
2602K1...		139									205		
		160										290	

# Motor/Drive Associations

## Spindle Motors General Description

### General Description

AMS Motor Power vs Speed and Torque vs Speed Characteristics

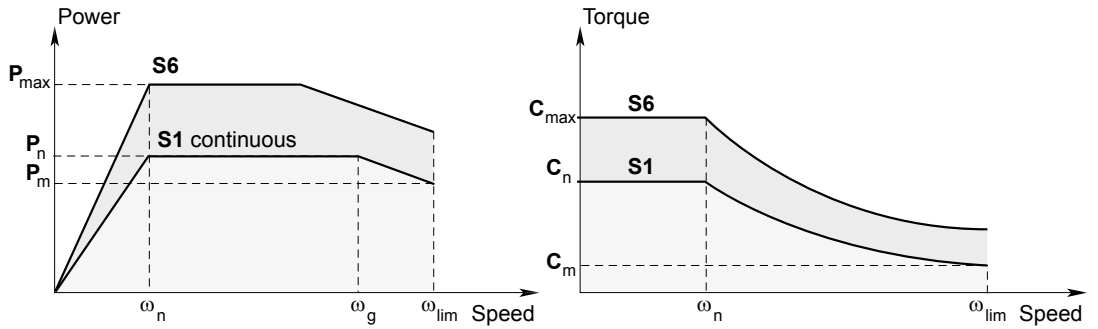

- $P_n$  = Rated continuous power (S1)
- $P_{max}$  = Overload power (S6)
- $P_m$  = Continuous power at maximum speed (S1)
- $\omega_n$  = Rated speed
- $C_n$  = Rated torque
- $C_{max}$  = Overload torque (S6)
- $\omega_g$  = Maximum speed at constant power (S1)
- $\omega_{lim}$  = Maximum speed
- $I_{cont}$  = Rated continuous current (S1)
- $I_{ms}$  = Overload current with the associated drive (S6)

### Services

	S2	S3	S6
Load			
Electrical losses			
Temperature			
Time	–	$f_m = \frac{N}{N+R} \times 100 (\%)$	$f_m = \frac{N}{N+V} \times 100 (\%)$

- N** = Operation at power  $P_{max}$
- R** = Idle
- V** = Off-load operation
- $f_m$**  = Duty cycle

# Motor/Drive Associations

## Spindle Motors

Association of AMS and IM Spindle Motors with NUMDrive X

### Association of AMS Motors with NUMDrive X (Switching Frequency 5 kHz)

AMS ...	Connection	MDLUX....	Continuous operation							Overload					
			S1							S6					
			Pn	wn	wg	wlim	Pm	Cn	Icont	Pmax	Cmax	Ims	10 min		
(kW)	(rpm)	(rpm)	(rpm)	(kW)	(Nm)	(Arms)	(kW)	(Nm)	(Arms)	(%)					
100	SB	Y	050A	3.7	1 500	6 500	6 500	3.7	24	20	6	40	35	22	
			050B												15(*)
	MB	Y	075A	5.5				5.5	35	26	10	80	53	13	
	GB	Y	130A	9				9	57	39	17	120	71	16	
	SD	Y	050A	3.7	1 500	6 500	12 000	1.8	24	20	6	40	35	22	
															050B
	MD	Y	075A	5.5				2.8	35	26	10	80	53	13	
GD	Y	130A	9	1 500	8 200		6.2	57	39	17	120	71	16		
132	SA	Y	075A	5	750	6 000	7 000	2.8	64	26	10	150	53	16	
	SC	Y	130A	10	1 500	6 000		8	64	39	19	122	71	20	
	SE	D	130A	15	1 750	4 000		10	82	52	23	110	71	30	
	MA	Y	130A	7.5	750	6 000		5.7	95	39	15	190	71	20	
	MC	Y	130A	15	1 500	6 000		12.5	95	52	21	134	71	37	
	ME	D	200A	19.5	2 000	6 500		19	100	72	35	149	106	30	
	LA	Y	130A	11	750	6 000		9	140	52	15	191	71	37	
	LE	Y	200A	22	1 250	4 200	15	168	72	36	229	106	30		
	SF	Y	075A	5	750	6 000	10 000	2	64	26	10	150	53	16	
	SG	Y	130A	10	1 500	6 000		6	64	39	19	122	71	20	
	SH	D	130A	15	1 750	4 000		7.5	82	52	23	110	71	30	
	MF	Y	130A	7.5	750	6 000		4	95	39	15	190	71	20	
	MG	Y	130A	15	1 500	6 000		9	95	52	21	134	71	37	
	MH	D	200A	19.5	2 000	6 500		13.5	100	72	35	134	106	30	
	LF	Y	130A	11	750	6 000		9 000	7	140	52	15	191	71	37
	LI	Y	130A	12.5	680	2 300	3		175	39	19	270	71	16	
	LH	Y	200A	22	1 250	4 200	12		168	72	36	229	106	30	
	160	MA	Y	130A	18	650	1 300		8 500	2.7	264	52	24	355	71
								D					178		
		MB	Y	200A	26	1 200	2 400		7.3	208	72	36	290	106	35
D												145			
MC		D	200A	36	1 700	2 800		11.8	202	100	47	265	141	10	
LA		Y	130A	18	500	1 000	6 500	2.8	344	52	24	463	71	35	
								D				231			
LB		Y	200A	26	950	1 900		7.6	260	72	36.4	364	106	35	
								D				182			
LC		D	200A	36	1 050	2 100		11.6	328	100	48	437	141	10	

(\*) Performance limited by drive type association (Bi-Axis drive)

### IM Motor

IM ...	Connection	MDLUX....	Continuous operation							Overload			
			S1							S6			
			Pn	wn	wg	wlim	Pm	Cn	Icont	Pmax	Cmax	Ims	10 min
(kW)	(rpm)	(rpm)	(rpm)	(kW)	(Nm)	(Arms)	(kW)	(Nm)	(Arms)	(%)			
18MK14	YY	400A	55	1 050	2 100	7 500	16.5	500	145	76	690	200	40



	Page
<b>Description</b>	<b>189</b>
<b>Power Supply Characteristics</b>	<b>191</b>
<b>Servodrive Interoperability</b>	<b>193</b>
<b>Servodrive Technical Characteristics</b>	<b>195</b>
<b>Servo Drive and Power Supply</b>	<b>197</b>
Outlines Size 1 and 2	197
Outlines Size 4	198
Outlines Size 6	199
<b>Power Supply Ordering Code</b>	<b>200</b>
<b>Servo Drive Ordering Code</b>	<b>201</b>



### NUMDrive X

The modern design of NUMDrive X servo drives makes them the ideal counterpart to the powerful Flexium<sup>+</sup> CNC.

One distinguishing feature of the NUMDrive X is its high power density. The servo drives offer an enormous amount of computing and drive power within a very small space and thus have one of the highest power/volume ratios available. A high degree of integration and efficiency has allowed us to achieve an extremely compact design that makes NUMDrive X one of the smallest high-end drives on the market. Thanks to a small depth and a modular width (a multiple of 50 mm) the cabinet layout is greatly simplified.

The range is characterized by a wide choice of current from a few amperes up to 200 Arms, Bi-Axis versions are available up to 2x35 Arms to enable each application to be optimized at the lowest cost. For the maximum contour precision, speeds and cost-effectiveness, the NUMDrive X servo drives can be exactly adapted to the particular machine and application.

NUMDrive X is a modular system that is optimized for multi-axis applications. Use of a common power supply unit means that only one mains connection, one line filter and one braking resistor are required per system, reducing cabling and overall costs. The system's modularity also facilitates energy exchange between different axes via the DC bus, offers the possibility of using stored energy for retraction purposes, and – in the case of regenerative power supplies – allows energy to be re-injected into the mains to reduce machine operating cost. Such system conception also leads the way for a greener approach.

NUMDrive X offers a choice of two performance levels:

- Standard-Performance (SP) drives
- High-Performance (HP) drives

Featuring high internal resolution, a short sampling time and specially developed algorithms, the HP versions are designed for sophisticated and complex applications in precision machine tools. The position control loop is closed with a very high bandwidth, achieving exceptional precision and speed at the mechanical interface of the machine (motor axis, linear motor). NUMDrive X accepts almost all measuring systems and can control a broad range of motors (servo, torque, linear, asynchronous motors) from NUM or other manufacturers. This ensures that a solution can be optimized from the technical and economic perspectives.

The HP versions of NUMDrive X also incorporate unique functionality known as DEM-X (Drive Embedded Macro). This allows users to create their own real-time macro which can interact with all physical and virtual drive resources – even to the extent of manipulating the regulation algorithms. Users can design and implement filters and monitors, define test points and create pilot outputs that obey user-stipulated rules.

The SP versions of NUMDrive X are suited to systems and precision machine tools of medium complexity, as well as cost-sensitive applications.

Within the NUMSafe architecture, NUMDrive X provides the safe motion functionalities by means of two different modules:

- NUM-STOX is the basic module for implementing the Safe Torque Off function certified up to SIL 3 according to IEC 61508. This allows the realization of E-STOP functions category 0 and 1 according to EN60204-1
- NUM-SAMX is the extended functionality module which provides a huge number of safe motion monitoring functions. STO Safe Torque Off, SLS Safely Limited Speed, SOS Safe Operational Stop, SS1 Safe Stop 1, SS2 Safe Stop 2, SLP Safe Limited Position and SDM (Safe Direction Monitoring)

Every machine builder has experienced the complexity of encoder wiring and knows that it takes time and effort to install and debug satisfactorily. NUMDrive X introduces a revolutionary innovation to overcome these issues. The drive incorporates a full digital encoder interface which uses a two-wire communication protocol. The two wires are integrated in the power cable. For more detailed characteristics on such encoders please refer to the Motors chapter.

For controlling auxiliary axes or auxiliary spindles, the NUMDrive C with CANopen interface is the most suitable solution. The CAN interface complies with a subset of the Device Profile DS402. The EDS (Electronic Data Sheet) files are available for the application of Mono-Axis and Bi-Axis versions.



### General Characteristics

Power Supply AC/DC Converter	
- Input Voltage	400 VACrms -10% to 480 VACrms +6% 3 phases
- Input Frequency	50/60Hz ± 5%
- Rated Power	from 15 kW up to 120 kW continuous power
- Dissipation of Braking Energy	reinjection in mains or braking resistors
Rated Output Current (DC/AC Converter)	from 4.2 Arms up to 200 Arms continuous current
Environment Storage Conditions	
- Temperature Range	0 to + 70°C
- Relative Humidity	max. 75% without condensation
Environment Working Conditions	
- Temperature Range	0 to 40°C without derating, max 60°C with derating
- Relative Humidity	max. 75% without condensation
- Vibration Stressing	Complies with EN 61800-5-1
- Altitude	0 to 1000 m without derating, max 3000 m with derating
- Pollution Degree	2, installation category II
- Electromagnetic Compatibility	Conforms to EN 61800-3
Functional Safety with NUM-SAMX	
- Safety Integrity Level (SIL)	up to 3 (IEC61800-5-2)
- PL	e (EN13849-1)
Functional Safety with NUM-STOX	
- Safety Integrity Level (SIL)	up to 3 (IEC61800-5-2)
- PL	d (EN13849-1)

### Power Supply Technical Characteristics (MDLL)

MDLL power supplies are designed to be used in conjunction with NUMDrive C and NUMDrive X. MDLLs supply the DC bus voltage and the control voltage (auxiliary voltage).

MDLLs are available in various power ratings and with dissipation of the braking energy by external resistor or with reinjection into the mains.

MDLQ is an auxiliary power supply used whenever the available built-in auxiliary power of the MDLL isn't sufficient (high number of drives). Refer to the installation manual for more information.

### Passive Power Supply with Braking Resistor

MDLL3 Power Supplies		MDLL3015N00AN0I	MDLL3030N00AN0I
Rated Power (S1)	kW	15	30
S3 Power (4s ON - 6s OFF)	kW	40	45
Peak Power	kW	50	50
Maximum Continuous Braking Power	kW	15	30
Peak Braking Power	kW	51	61
Rated Input Voltage	V	400 VACrms -10% to 480 VACrms +6% 50/60Hz ± 5% 3 phases	
Rated Input Current	Arms	31 (cosφ 0.7)	62 (cosφ 0.7)
DC Bus Voltage at Rated Power	Vdc	540 Vdc with 400 Vrms input, 650 Vdc with 480 Vrms input	
Dissipation of Braking Energy		On braking resistor	
Auxiliary Rated Power	W	230	
Protection Degree (EN60529)		IP20	
Overall Dimensions (WxHxD)	mm	100 x 355 x 206	
Weight	kg	5.5	

### Regenerative Power Supply with Mains Reinjection

MDLL3 Power Supplies		MDLL3025N00RN0I	MDLL3050N00RN0I
Rated Power (S1)	kW	25	50
S3 Power (4s ON - 6s OFF)	kW	50	97
Peak Power	kW	50	97
Maximum Continuous Braking Power	kW	25	50
Peak Braking Power	kW	61	120
Rated Input Voltage	V	400 VACrms -10% to 480 VACrms +6% 50/60Hz ± 5% 3 phases	
Rated Input Current	Arms	50 (cosφ 0.7)	100 (cosφ 0.7)
DC Bus Voltage at Rated Power	Vdc	540 Vdc with 400 Vrms input, 650 Vdc with 480 Vrms input	
Dissipation of Braking Energy		Reinjection in mains	
Auxiliary Rated Power	W	180	
Protection Degree (EN60529)		IP00	
Overall Dimensions (WxHxD)	mm	200 x 355 x 206	
Weight	kg	11.5	

### Regenerative Power Supply with Mains Reinjection and Controlled DC Bus Voltage

MDLL3 Power Supplies		MDLL3025N00HN0I	MDLL3050N00HN0I	MDLL3120N00HN0I
Rated Power (S1)	kW	25	50	120
S3 Power (4s ON - 6s OFF)	kW	50	97	150
Peak Power	kW	50	97	190
Maximum Continuous Braking Power	kW	25	50	120
Peak Braking Power	kW	61	120	200
Rated Input Voltage	V	400 VACrms -10% to 480 VACrms +6% 50/60Hz ± 5% 3 phases		
Rated Input Current	Arms	36 (cosφ 1)	72 (cosφ 1)	173 (cosφ 1)
DC Bus Voltage at Rated Power	Vdc	Configurable DC Bus voltage: 600, 650, 700 Vdc		
Dissipation of Braking Energy		Reinjection in mains		
Auxiliary Rated Power	W	180		200
Protection Degree (EN60529)		IP00		
Overall Dimensions (WxHxD)	mm	200 x 355 x 206		300 x 355 x 206
Weight	kg	11.5		19

### Auxiliary Power Supply for Control Voltage

MDLQ3 Power Supply		MDLQ3001N00
Auxiliary Rated Power	W	250
Input Voltage	V	400 VACrms -10% to 480 VACrms +6% 50/60Hz ± 5% 2 phases
Protection Degree (EN60529)		IP20
Overall Dimensions (WxHxD)	mm	50 x 355 x 206
Weight	kg	2.8

The MDLQ auxiliary power supply is only required if the MDLL's auxiliary output has insufficient power to meet the control voltage supply needs of the complete drive line-up. See installation manual for details.

# NUMDrive X

## Servodrive Interoperability



### Servodrive Interoperability and Functions (MDLUX)

		Bi-Axis SP	Mono-Axis HP	Bi-Axis HP
Interface	High speed digital bus DISC NT+	•	•	•
Control Performance	Standard performance control loops	•	•	•
	High performance control loops	–	•	•
Compatible Motors	Closed loop: synchronous rotary motors	•	•	•
	Closed loop: synchronous torque and linear motors	–	•	•
	Closed loop: asynchronous motors	•	•	•
	Open loop: asynchronous motors (V/F mode)	•	•	•
Compatible Motor Sensor	Hiperface encoder	•	•	•
	Single cable motor encoder (SHX, SPX motors)	•	•	•
	EnDat 2.1 & EnDat 2.2 encoder	•	•	•
	1 Vpp toothed wheel / encoder	•	•	•
	Renishaw RESOLUTE™ encoders with BiSS interface Magnescale encoders	•	•	•
Compatible Direct Measure Sensors	EnDat 2.1 & EnDat 2.2 encoder / linear scale	–	•	•
	Hall sensors	–	•	•
	1 Vpp encoder / linear scale (also with coded references)	–	•	•
	Renishaw RESOLUTE™ encoder with BiSS interface Magnescale encoders	–	•	•
Special Functions	Spindle operation for synchronous and asynchronous motors	•	•	•
	Synchronous motor phasing without movement	•	•	•
	Spindle-Axis commutation	•	•	•
	Star/Delta commutation on the fly (for asynchronous motor)	–	•	•
	Rotary axis with mechanical ratio not 2x	•	•	•
	AP03: Anti-backlash function	–	○	○
	AP04: Torque duplication	–	○	○
	AP05: Winding duplication	–	○	○
	DEM-X: Drive Embedded Macro	–	○	○
	Coherence control between motor and direct measure sensor	–	•	•
	Various active dumping functions	–	•	•
	Various freely settable filters	•	•	•
	EPS: Electrical Position Synchronization	–	•	•
AP01: Absolute position with motor's multi-turn encoder and incremental direct measure sensor	–	•	•	



### Servodrive Interoperability and Functions (MDLUX)





		Bi-Axis SP	Mono-Axis HP	Bi-Axis HP
Safety Functions Compliant with EN 61800-5-2	NUM-STOX module with Safe Torque Off	○	○	○
	NUM-SAMX module with	○	○	○
	- STO Safe Torque Off			
	- SLS Safely Limited Speed			
	- SOS Safe Operational Stop			
	- SS1 Safe Stop 1			
	- SS2 Safe Stop 2			
- SLP Safe Limited Position				
- SDM Safe Direction Monitoring				

### Servodrive Technical Characteristics (MDLUX)

MDLUX servodrive modules must always be selected to suit the associated motor. They are available in 11 ratings as shown below.

All MDLUX modules have the same depth and height, and their width varies in standard modular increments (multiples of 50mm), allowing easy mounting in electrical cabinets. A built-in brake management scheme eliminates the need for an external control relay.

NUMDrive X Power Range Overview:

MDLUX Module Size	Type	Reference	Rated Current	Maximum Current
<b>Size 1, 50mm</b> 	Mono-Axis	MDLUX007A1xxN0I	4.4 Arms	5 Arms
		MDLUX014A1xxN0I	8.9 Arms	10 Arms
		MDLUX021A1xxN0I	13 Arms	15 Arms
		MDLUX034A1xxN0I	13 Arms	24 Arms
	Bi-Axis	MDLUX007B0xxN0I	3.1 + 3.1 Arms	5 + 5 Arms
		MDLUX014B0xxN0I	6.3 + 6.3 Arms	10 + 10 Arms
<b>Size 2, 100mm</b> 	Mono-Axis	MDLUX050A1xxN0I	28 Arms	35 Arms
		MDLUX075A1xxN0I	34 Arms	53 Arms
	Bi-Axis	MDLUX050B1xxN0I	20 + 20 Arms	35 + 35 Arms
<b>Size 4, 200mm</b> 	Mono-Axis	MDLUX130A1xxN0I	60 Arms	92 Arms
		MDLUX200A1xxN0I	100 Arms	141 Arms
<b>Size 6, 300mm</b> 	Mono-Axis	MDLUX400A1xxN0I	200 Arms	282 Arms

### Mono-Axis Drive up to 34A

Mono-Axis		MDLUX007A		MDLUX014A...		MDLUX021A...		MDLUX034A...	
		5	10	5	10	5	10	5	10
Switching Frequency	kHz	5	10	5	10	5	10	5	10
Rated Current (S1)	Arms	4.4	4.4	8.9	6	13	8	13	8
Maximum Current	Arms	5		10		15		24	
Auxiliary Power Consumption *	W	18.5							
Protection Degree (EN60529)		IP20							
Overall Dimensions (WxHxD)	mm	50 x 355 x 206							
Weight	kg	3							

\* Without considering sensor power supply. Add 1W for each connected sensor (motor or direct).

### Mono-Axis Drive up to 400A

Mono-Axis		MDLUX050A...		MDLUX075A...		MDLUX130A...		MDLUX200A...		MDLUX400A...	
		5	10	5	10	5	10	5	10	5	10
Switching Frequency	kHz	5	10	5	10	5	10	5	10	5	10
Rated Current (S1)	Arms	28	18	34	23	60	42	100	70	200	130
Maximum Current	Arms	35		53		92		141		282	
Auxiliary Power Consumption *	W	22.5				42.5				27.5	
Protection Degree (EN60529)		IP20				IP00					
Overall Dimensions (WxHxD)	mm	100 x 355 x 206				200 x 355 x 206				300 x 355 206	
Weight	kg	5.9				11				15	

\* Without considering sensor power supply. Add 1W for each connected sensor (motor or direct).

### Bi-Axis Drive

Bi-Axis		MDLUX007B...		MDLUX014B...		MDLUX021B...		MDLUX050B...	
		5	10	5	10	5	10	5	10
Switching Frequency	kHz	5	10	5	10	5	10	5	10
Rated Current (S1)	Arms	3.1 + 3.1	3.1 + 3.1	6.3 + 6.3	4.2 + 4.2	6.3 + 6.3	4.2 + 4.2	20 + 20	13 + 13
Maximum Current	Arms	5 + 5		10 + 10		15 + 15		35 + 35	
Auxiliary Power Consumption *	W	21.5				28.5			
Protection Degree (EN60529)		IP20							
Overall Dimensions (WxHxD)	mm	50 x 355 x 206				100 x 355 x 206			
Weight	kg	3				6.2			

\* Without considering sensor power supply. Add 1W for each connected sensor (motor or direct).

Refer to installation manual for more information and dimensioning rules.

# NUMDrive X

Servo Drive and Power Supply  
Outlines Size 1 and 2

## MDLUX & MDLL Outlines (Size 1 and 2)

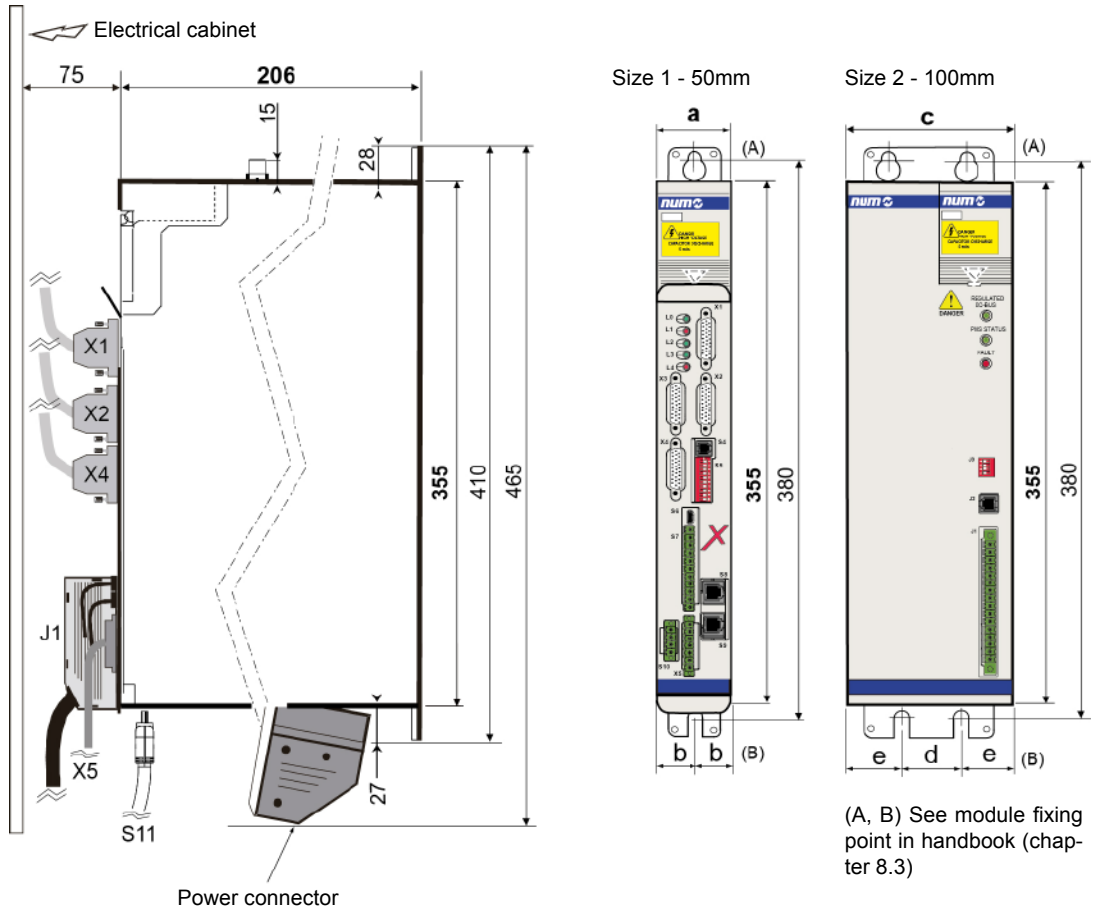

Module Description	Code	Module Size	Dimensions				
			a	b	c	d	e
<b>MDLL3 Module</b>	MDLL3015N00AN0I	Size 2 - 100mm	100	50	25		
	MDLL3030N00AN0I						
MDLUX050A1xxN0I							
MDLUX075A1xxN0I							
MDLUX050B1xxN0I							
MDLUX007A1xxN0I							
MDLUX014A1xxN0I							
MDLUX021A1xxN0I							
MDLUX034A1xxN0I							
MDLUX007B0xxN0I							
<b>NUMDrive X Modules</b>	MDLUX014B1xxN0I	Size 1 - 50mm	50	25			
	MDLUX021B1xxN0I						
<b>Additional 250W AUX Module</b>	MDLQ3001N00						

# NUMDrive X

Servo Drive and Power Supply  
Outlines Size 4

## MDLUX & MDLL Outlines (Size 4)

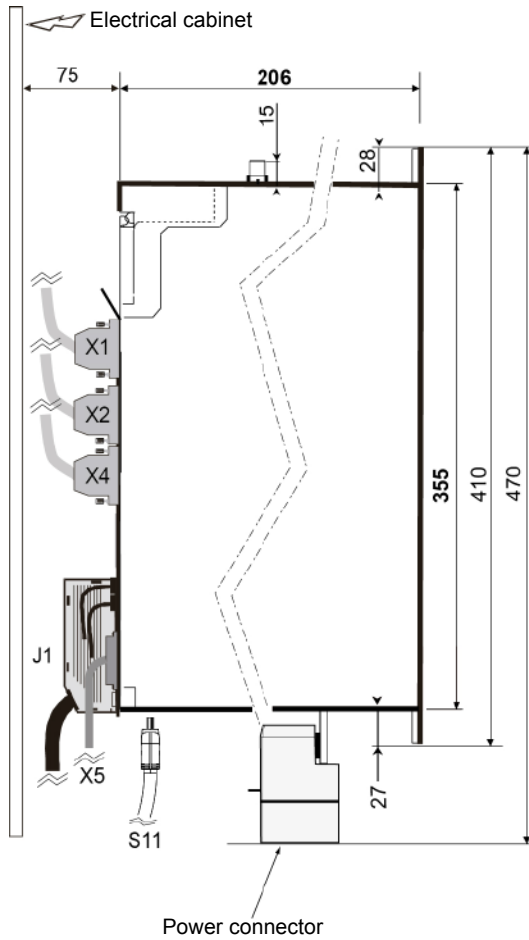

MDLL3 and MDLUX size 4 overall dimensions

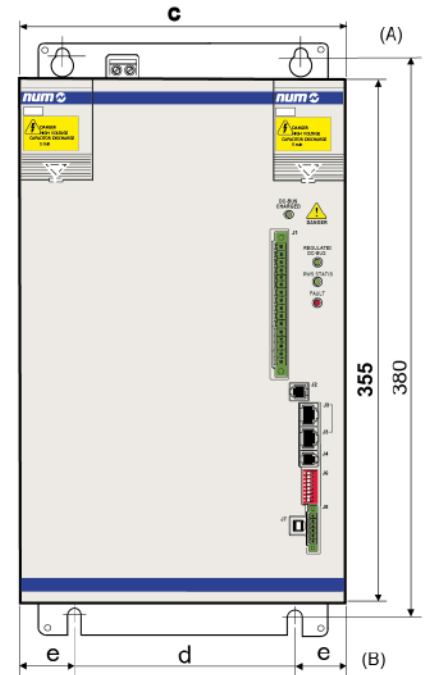

(A, B) See module fixing point in handbook (chapter 8.3)

Module Description	Code	Module Size	Dimensions				
			a	b	c	d	e
<b>MDLL3 Module</b>	MDLL3025N00RN0I	Size 4 - 200mm			200	150	25
	MDLL3050N00RN0I						
	MDLL3025N00HN0I						
	MDLL3050N00HN0I						
<b>NUMDrive X Modules</b>	MDLUX130A1xxN0I						
	MDLUX200A1xxN0I						

# NUMDrive X

Servo Drive and Power Supply  
Outlines Size 6

## MDLUX & MDLL Outlines (Size 6)

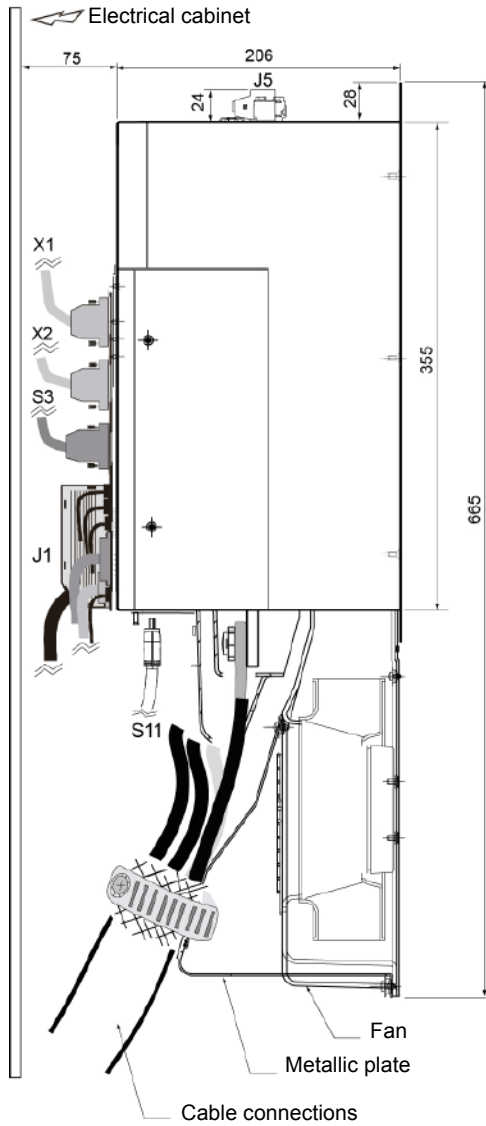

MDLL3 and MDLUX size 6 overall dimensions  
(with fan and metallic plate)

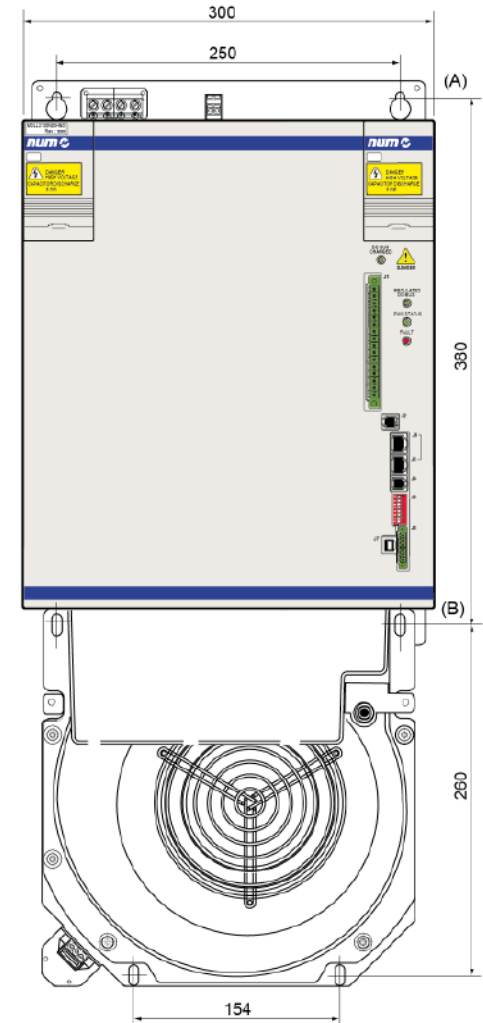

(A, B) See module fixing point in handbook (chapter 8.3)

Module Description	Code	Module Size
<b>MDLL3 Module</b>	MDLL3120N00HN0I	Size 6 - 300mm
<b>NUMDrive X Modules</b>	MDLUX400A1xxN0I	

# NUMDrive X

## Power Supply Ordering Code

### Power Supply

	MDLL	3	015	N	00	A	N	0	I
<b>Series</b>									
<b>Evolution Index</b>									
<b>Rated Power</b>									
- Size 2: Pn 15kW			015						
- Size 2: Pn 30kW			030						
- Size 4: Pn 25kW			025						
- Size 4: Pn 50kW			050						
- Size 6: Pn 120kW <sup>5</sup>			120						
<b>Mains Supply</b>									
- From 400Vac -10% to 480Vac +6% 50/60Hz +/-5%, 3 phases				N					
<b>Options</b>									
- None					00				
<b>Type</b>									
- Passive power supply <sup>1,2</sup>						A			
- Regenerative power supply <sup>1,3,4</sup>						R			
- Regulated DCBus power supply <sup>1,3,4</sup>						H			
<b>Version</b>									
- Standard NUM							N		
<b>Standard NUM</b>								0	
<b>Heat-Sink Position</b>									
- Internal heat-sink									I

<sup>1</sup> An external braking resistor must be always used

<sup>2</sup> Not available on Pn 25kW, Pn 50kW and Pn 120kW sizes

<sup>3</sup> Not available on Pn 15kW and Pn 30kW sizes

<sup>4</sup> An external line choke must be always used

<sup>5</sup> An external AGOFAN001 and AEOKIT003 must be always taken in account

### Servodrive

	MDLUX	014	A	1	C	A	N	0	I
<b>Series</b>									
<b>Rated Power</b>									
<b>Mono-Axis</b>									
- Size 1: In 4.4Arms, Ipeak 5Arms		007							
- Size 1: In 8.9Arms, Ipeak 10Arms		014							
- Size 1: In 13Arms, Ipeak 15Arms		021							
- Size 1: In 13Arms, Ipeak 24Arms		034							
- Size 2: In 28Arms, Ipeak 35Arms		050							
- Size 2: In 34Arms, Ipeak 53Arms		075							
- Size 4: In 60Arms, Ipeak 92Arms		130							
- Size 4: In 100Arms, Ipeak 141Arms		200							
- Size 6: In 200Arms, Ipeak 282Arms <sup>1</sup>		400							
<b>Bi-Axis</b>									
- Size 1: In 3.1+3.1Arms, Ipeak 5+5Arms		007							
- Size 1: In 6.3+6.3Arms, Ipeak 10+10Arms		014							
- Size 1: In 6.3+6.3Arms, Ipeak 15+15Arms		021							
- Size 2: In 20+20Arms, Ipeak 35+35Arms		050							
<b>Axis Number</b>									
- Mono-Axis			A						
- Bi-Axis			B						
<b>Communication</b>									
- DISC NT+ <sup>2</sup>				1					
<b>Version</b>									
- Standard Performance <sup>3</sup>					A				
- High Performance					C				
- High Performance with external link <sup>4</sup>					D				
<b>Safety</b>									
- Without Safety module						A			
- NUM-STOX (Safe Torque Off) module according to EN61800-5-2 up to SIL 3						E			
- NUM-SAMX Safety module according to EN61800-5-2 up to SIL 3						S			
<b>Standard NUM</b>							N		
<b>Fixed Value</b>								0	
<b>Heat-Sink Position</b>									
- Internal heat-sink									I

<sup>1</sup> An external AGOFAN001 and AEOKIT005 must be always taken in account

<sup>2</sup> DISC NT bus HDMI-HDMI cable connection.

<sup>3</sup> Not available with Mono-Axis version

<sup>4</sup> Not available for Bi-Axis version, required for Mono-Axis tandem function



# NUM EtherCAT Terminals

## Table of Contents

	Page
<b>General Characteristics</b>	<b>205</b>
<b>Gateways and Terminals</b>	<b>207</b>
<b>Ordering Code &amp; Example</b>	<b>208</b>
<b>Technical Data and System Structure</b>	<b>209</b>



# NUM EtherCAT Terminals

## General Characteristics

### General Characteristics

NUM's EtherCAT Terminal is a modular system available with different configurable devices:

- Gateway modules CTMG1100
- Extension modules CTMG1110
- Digital and Analogue I/O modules CTMTxxxx
- Safe PLC modules CTMP6900 <sup>1</sup>
- Safe I/O modules modules CTMS1904 and CTMS2904 <sup>1</sup>
- Technology modules CTMTxxxx

Machine builders can easily create their own configurations from a mix of different devices. Each line-up requires a gateway to receive messages from the EtherCAT field bus and propagate them to the different devices via the internal E-bus. Please also refer to chapter 2 for further information on NUM's EtherCAT process and terminal combinations.

<sup>1</sup>For more detailed information on the Safe PLC and Safe I/O modules please refer to the M00033, M00034 and M00035 manuals.

### NUM EtherCAT Terminals Mixed Combination

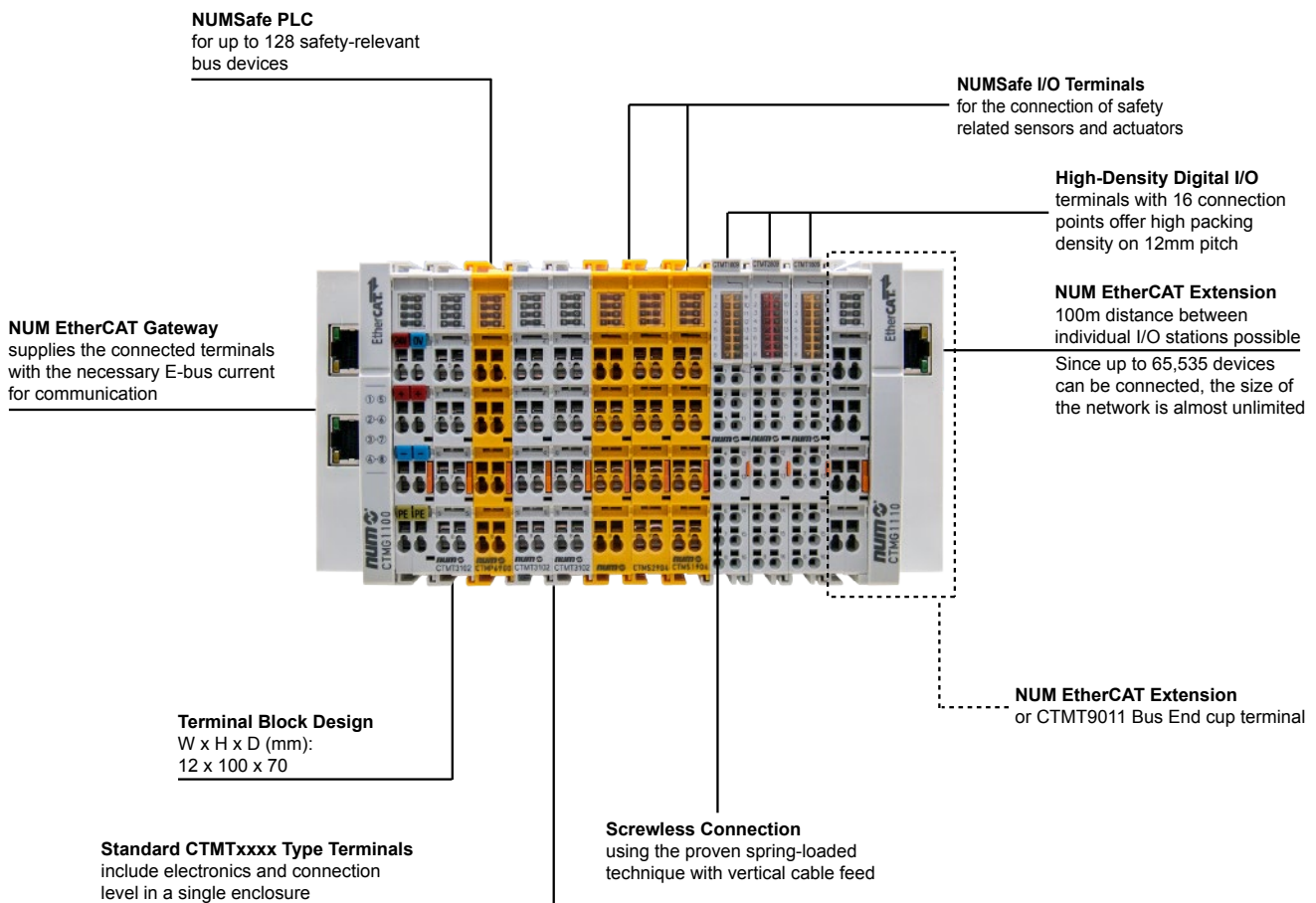

### Structure

---

Robust housings, secure contacts and solidly built electronics are prominent features of NUM components. An I/O station consists of an EtherCAT Gateway and almost any number of terminals. Since up to 65,535 devices can be connected, the size of the network is almost unlimited.

The electronic terminal blocks are attached to the EtherCAT Gateway. The contacts are made as the terminal clicks into place, without any other manipulation.

This means that each electronic terminal block can be individually exchanged. It can be placed on a standard DIN rail.

A clearly arranged connection panel with LEDs for status display and push-in contact labels ensures clarity in the field. 3-wire conductors with an additional connection for a protective conductor, enable direct connection of sensors and actuators.

### Free Mix of Signals

---

Suitable EtherCAT Terminals are available for all common digital and analog signal types encountered in the world of automation. NUM EtherCAT Terminals enable bit-precise composition of the required I/O channels.

The digital EtherCAT Terminals are designed as 2-, 4-, 8- or 16-channel terminals.

In the 16-channel variant, digital input and output signals are arranged in an ultra-compact way within a standard terminal housing across a width of only 12mm. The standard analog signals of  $\pm 10$  V, 0...10 V, 0...20mA and 4...20mA are all available as 1-, 2-, 4- and 8-channel variants within a standard housing.

# NUM EtherCAT Terminals

## Gateways and Terminals

### Gateways and Terminals

Description	Commercial Reference	Task / Connection Technology
<b>Gateway</b>		
EtherCAT gateway	<b>CTMG1100</b>	Connects EtherCAT with terminal
EtherCAT extension	<b>CTMG1110</b>	Extends EtherCAT connection
<b>Digital Input</b>		
4-channel digital input terminal 24 V DC, 3 ms	<b>CTMT1004</b>	2-wire connection
8-channel digital input terminal 24 V DC, 3 ms	<b>CTMT1008</b>	1-wire connection
HD EtherCAT Terminal, 4-channel digital input 24 V DC	<b>CTMT1804</b>	3-wire connection
HD EtherCAT Terminal, 16-channel digital input 24 V DC	<b>CTMT1809</b>	1-wire connection
<b>Digital Output</b>		
4-channel digital output terminal 24 V DC, 0.5 A	<b>CTMT2004</b>	2-wire connection
8-channel digital output terminal 24 V DC, 0.5 A	<b>CTMT2008</b>	1-wire connection
4-channel digital output terminal 24 V DC, 2A	<b>CTMT2024</b>	2-wire connection
2-channel relay output terminal 230 V AC, 2A	<b>CTMT2602</b>	Relay output, 4-wire connection
2-channel relay output terminal, 125 V AC, 1A	<b>CTMT2612</b>	Relay output
HD EtherCAT Terminal, 16-channel digital output 24 V DC, 0.5 A	<b>CTMT2809</b>	1-wire connection
<b>Analog Input</b>		
2-channel analog input terminal -10...+10 V, differential input, 16 bits	<b>CTMT3102</b>	2 (differential) Inputs
2-channel analog input terminal 4...20 mA, differential input, 16 bits	<b>CTMT3122</b>	2 (differential) Inputs
2-channel analog input terminal 0...10 V, single-ended, 16 bits	<b>CTMT3162</b>	2 (single-ended) Inputs
2-channel input terminal PT100 (RTD) for 2- or 3-wire connection	<b>CTMT3202</b>	2 Inputs, 2- or 3 wire (default 3-wire) connection
<b>Analog Output</b>		
2-channel analog output terminal 0...10 V, 16 bits	<b>CTMT4102</b>	2 (single ended) Outputs, 2-wire
2-channel analog output terminal 4...20 mA, 16 bits	<b>CTMT4122</b>	2 (single ended) Outputs, 2-wire
2-channel analog output terminal -10...+10 V, 16 bits	<b>CTMT4132</b>	2 (single ended) Outputs, 2-wire
<b>Communication</b>		
Serial interface 1 x RS232	<b>CTMT6001</b>	
Serial interface 1 x RS422/RS485	<b>CTMT6021</b>	
<b>System Terminals</b>		
End cap	<b>CTMT9011</b>	
Potential supply, 24 V DC	<b>CTMT9100</b>	
Potential supply, 24 V DC, with diagnostics	<b>CTMT9110</b>	
Potential supply, arbitrary up to 230 V AC/DC	<b>CTMT9190</b>	
Power supply terminals for E-bus	<b>CTMT9410</b>	24V Input, to refresh E-bus
<b>Encoder Terminals</b>		
Incremental encoder interface, differential inputs	<b>CTMT5101</b>	Incremental encoder interface RS485
1-channel incremental encoder interface	<b>CTMT5151</b>	Incremental encoder interface 24 V DC

#### NUM EtherCAT product identification:

**CTMx:** Communication to machine

**CTMG:** Gateway

**CTMT:** Terminals

#### Important Remark:

CTMT2602 and CTMT2612 requires a potential separation terminal CTMT9190 to prevent collision to 125V/230V power contacts

### Ordering Code

---

NUM's EtherCAT terminals usually have an 8-digit identifier, which is printed on the device or attached to it on a sticker.

**CTMx xxxx**

NUM part number (item description)

G = Gateway

T = Terminal

P = Safe PLC

S = Safe Terminal

---

### Example

---

Example of EtherCAT Gateway Terminal **CTMG1100**

- **CTM** Structure of production
- **G** Gateway identification
- **1100** Part number

Please also refer to the previous page for more detailed information.

# NUM EtherCAT Terminals

## Technical Data and System Structure

### Technical Data

For detailed technical information about NUM's CTMG or CTMT EtherCAT terminals, please refer to reference manual M00032EN-00.

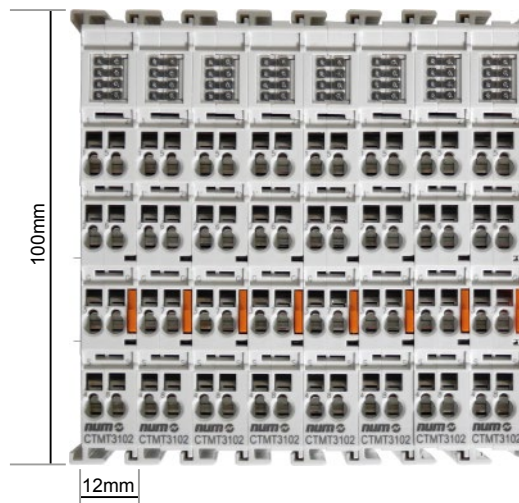

Note 1:

Nearly all types of CTMT terminals have the same dimensions.

Note 2:

NUM's CTMG and CTMT EtherCAT terminals are available from stock. For information about particular logic components, or to check their availability, please contact your local NUM sales office.





	Page
<b>Overview</b>	<b>213</b>
<b>System Cables</b>	<b>218</b>
<b>System Connectors</b>	<b>220</b>
<b>NUMDrive X Connectors and Adapters</b>	<b>221</b>
<b>NUMDrive X Kits</b>	<b>223</b>
<b>Miscellaneous</b>	<b>226</b>
<b>NUMDrive X Line Filters</b>	<b>227</b>
<b>NUMDrive X Line Chokes</b>	<b>230</b>
<b>NUMDrive X Braking Resistor</b>	<b>234</b>
<b>Auto-Transformer</b>	<b>238</b>
<b>Motor Cables and Connectors</b>	<b>239</b>

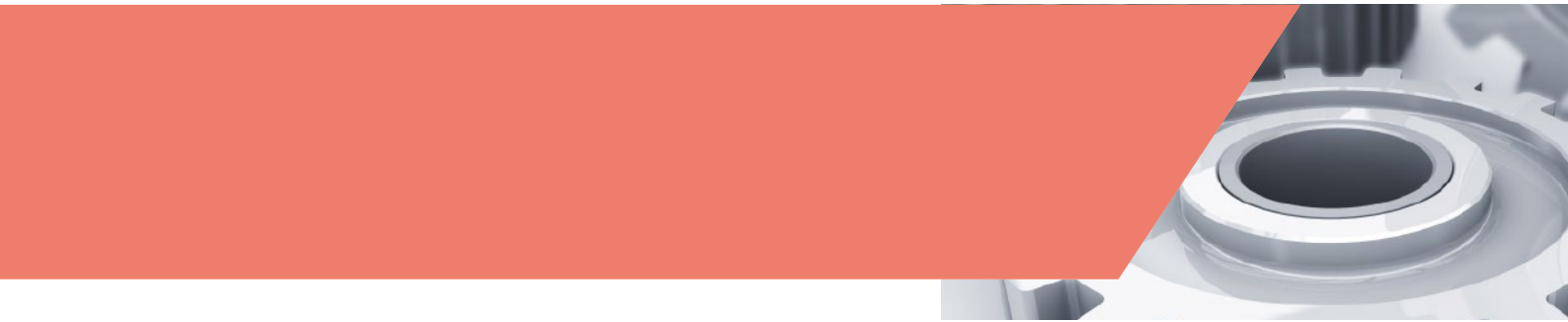

# Cables / Accessories

## Overview

### Main Accessories Overview

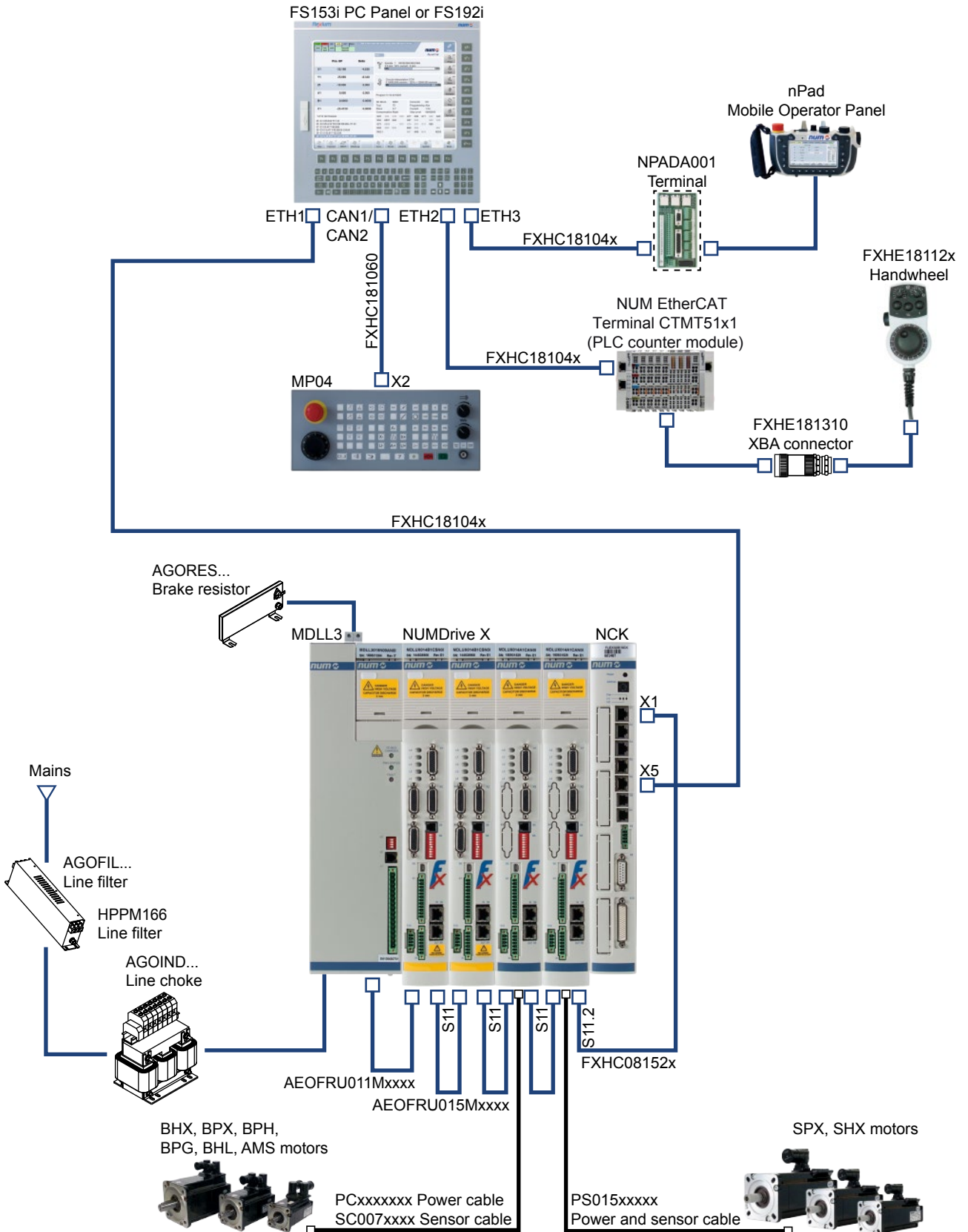

10



### Multi-NCK Clock-Synchro Configuration

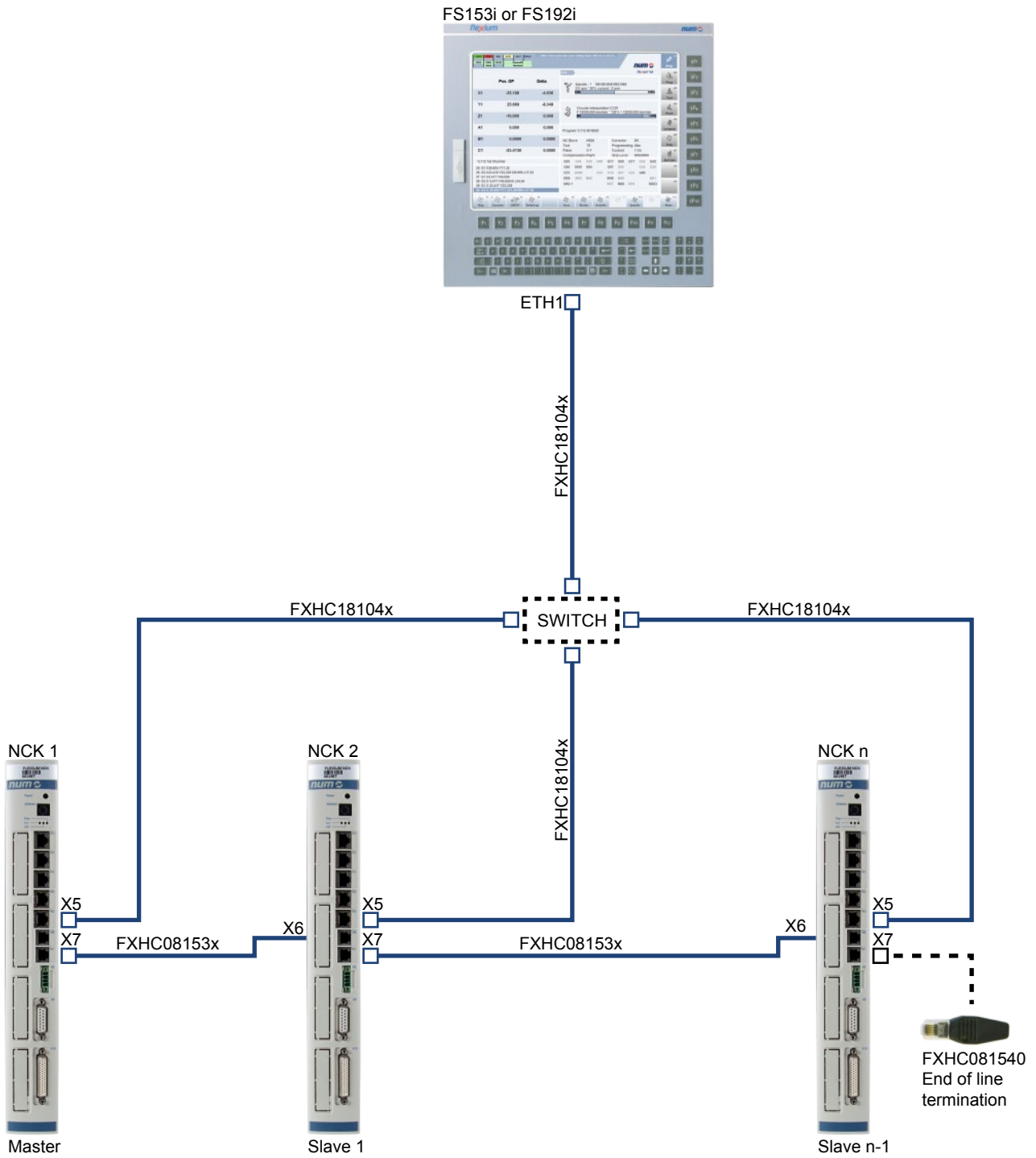



### NUMDrive X with NUM-SAMX Module

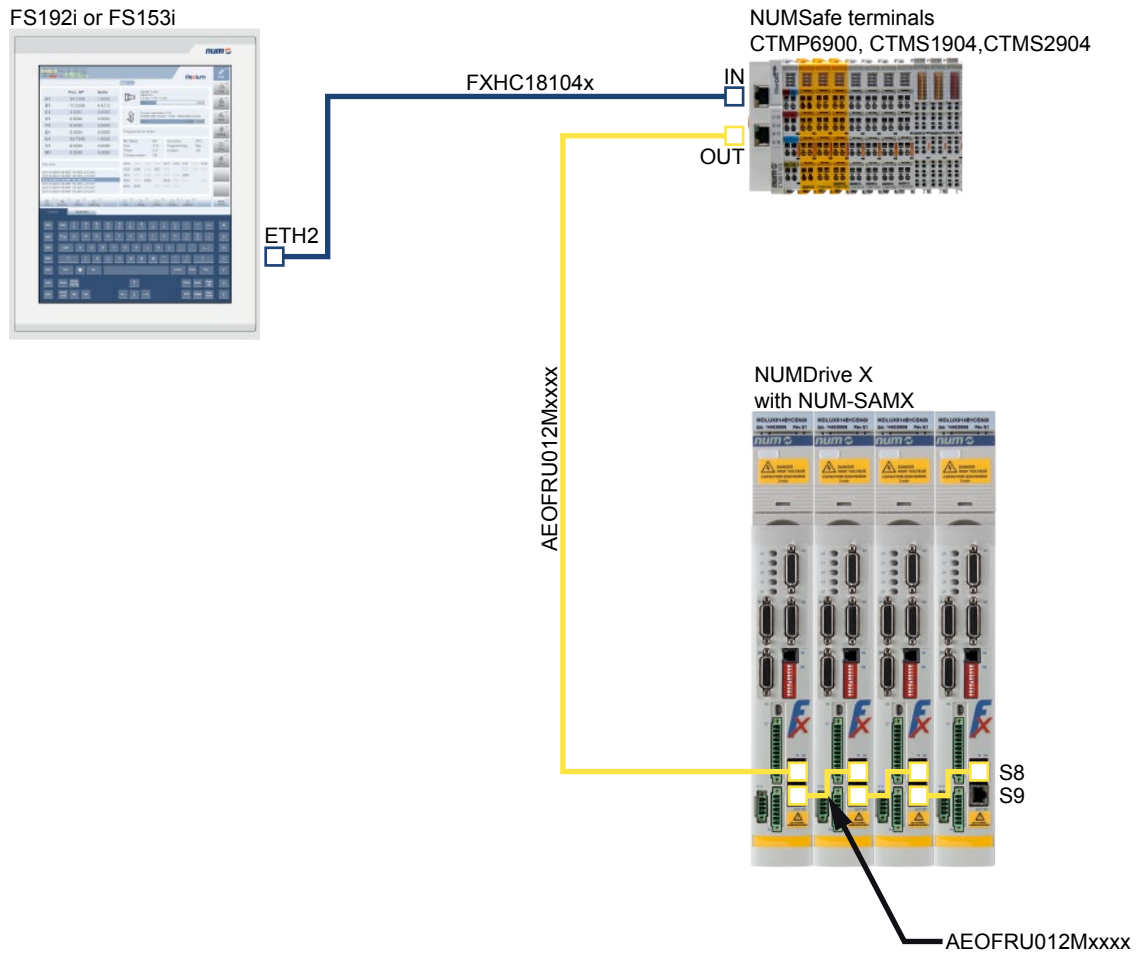



### NUMDrive X with NUM-STOX Module

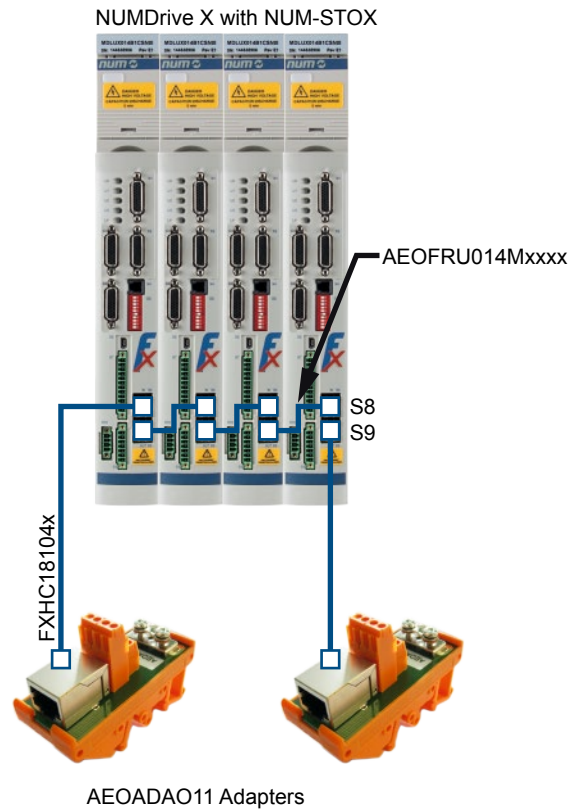

### NUMDrive X with Tandem Application

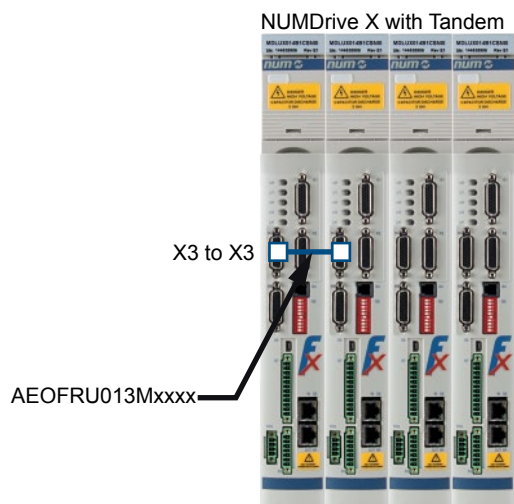

# Cables / Accessories

## Overview



### Mixed Configuration NUMDrive X with NUMDrive C CANopen Modules

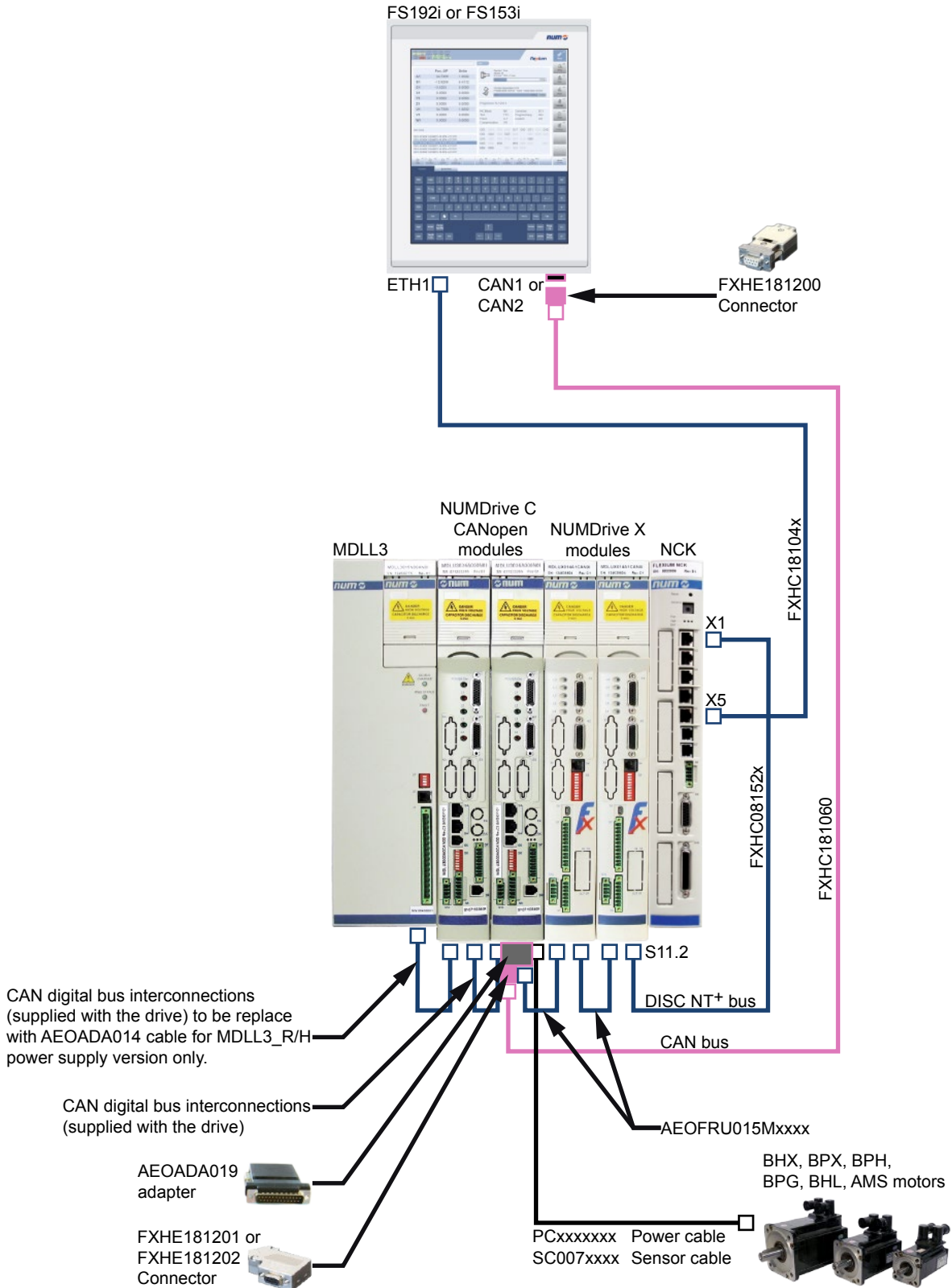

10



### System Cables

Accessories	Order Code	Description	
NCK to NUMDrive X Cable	FXHC081520 FXHC081521 FXHC081522 FXHC081523 FXHC081524	0.6 m length 1 m length 2.5 m length 5 m length 10 m length	
NCK to FS153i or 192i Cable	FXHC181040 FXHC181041 FXHC181042 FXHC181043 FXHC181044 FXHC181045 FXHC181046	0.5 m length 1 m length 2 m length 5 m length 10 m length 20 m length 30 m length	
NCK Clock-Synchro Cable	FXHC081530 FXHC081531 FXHC081532	0.2 m length 2.5 m length 5 m length	
CAN Cable PVC, Purple, Shielded in Pairs	FXHC181060	Cable only. Required length must be specified in the order.	
End of Line Termination	FXHC081540	End terminal RJ45 for Multi-NCK. Clock-Synchro version	







### System Cables

Accessories	Order Code	Description	
MDLL3 / MDLUX	AEOFRU011M0002 AEOFRU011M0004	MDLUX size 1 - 2 MDLUX size 4 - 6	
Cable for NUM-SAMX Connections (Yellow Cable RJ45)	AEOFRU012M0001 AEOFRU012M0002 AEOFRU012M0003 AEOFRU012M0004 AEOFRU012M0015 AEOFRU012M0020	MDLUX size 1 MDLUX size 2 MDLUX size 4 MDLUX size 6 Cable length 1.5 m Cable length 2 m	
Cable for Tandem: - Anti-Backlash - Torque Duplication - Winding Duplication	AEOFRU013M0001 AEOFRU013M0002 AEOFRU013M0003 AEOFRU013M0004	MDLUX size 1 MDLUX size 2 MDLUX size 4 MDLUX size 6	
Cable for NUM-STOX Connection (Grey Cable RJ45)	AEOFRU014M0001 AEOFRU014M0002 AEOFRU014M0003 AEOFRU014M0004	MDLUX size 1 MDLUX size 2 MDLUX size 4 MDLUX size 6	
MDLUX DISCNT+ Cable for MDLUX Digital Bus Interconnections	AEOFRU015M0001 AEOFRU015M0002 AEOFRU015M0003 AEOFRU015M0004	MDLUX size 1 MDLUX size 2 MDLUX size 4 MDLUX size 6	



### System Connectors

Accessories	Order Code	Description	
Connector Kit for Flexium <sup>+</sup> : - X9 Analog IOs - X10 Digital Ios	FXHE181301	X9 sub D 15 pin male connector X10 sub HD 44 pin male connector	
CAN Connector	FXHE181200	CAN female connector axial with integrated bus termination	
CAN Connector	FXHE181201	CAN male connector 90°	
CAN Connector	FXHE181202	CAN male/female connector 90° with prog. unit	



### NUMDrive X Connectors Kit

Accessories	Order Code	Description	
Drive Side Power and Brake Connector for 50 mm Module (M1 or M2)	AEOCON009	Drive power connector with polarization key and wire-pins.	
X1, X2, X3, X4 Drive Side Sensor Connector	AEOCON012	Sensor connector Sub D HD 26 pin M. (4/40" screw thread connector)	
Drive Side Power and Brake Connector for 100 mm Module (M1 or M2)	AEOCON013	Drive power connector, brake connectors + fixing device, metallic strip and polarization keys.	



### NUMDrive X Adapters

Accessories	Order Code	Description	
RJ45 NUM-STOX Cable to Terminal Adapter	AEOADA011	NUM-STOX adapter with wire terminal connections (8 screw terminals)	
CAN BUS Adapter MDLUX-MDLU3	AEOADA019	1 Sub D 25 pin M 1 HDMI 1 Sub D 9 pin F	
CAN BUS Adapter MDLU3-MDLL3	AEOADA020	1 Sub D 25 pin M 1 Sub D 25 pin F 1 Sub D 9 pin F Cable length 20 cm	
MDLUX Dual Row Adapter	AEOADA021	1 Sub D 9 pin F 1 HDMI 2 RJ45	
MDLUX Dual Ring Adapter	AEOADA022	2 HDMI 1 RJ45	



### MDLL3 Size 6 Power Supply Connection Kit

Accessories	Order code	Description
MDLL3120N00HN01 Power Supply Connection Kit	<b>AEOKIT003</b>	Mandatory connection kit. See figure.

#### AEOKIT003



Metallic strip 50mm for DC Bus



Self locking nut M8



Self locking nut M3



Plastic protection



Eyebolt M8



16 pin connector



Plug connector  
AUX



Shell for 16 pin connector



Metallic strip



Metallic plate for cable and shield fixing

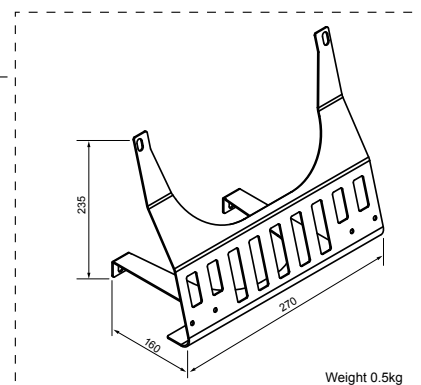

Weight 0.5kg



### MDLUX Size 6 Drive Connection Kit

Accessories	Order code	Description
MDLUX400A1xxN01 Drive Connection Kit	<b>AEOKIT005</b>	Mandatory connection kit. See figure.

#### AEOKIT005



Metallic strip 50mm for DC Bus



Self locking nut M8



Self locking nut M3



Plastic protection



Eyebolt M8



Plug connector  
AUX



7 pin connector



Metallic strip



12 pin connector



Brake connector



Metallic plate for cable and shield fixing

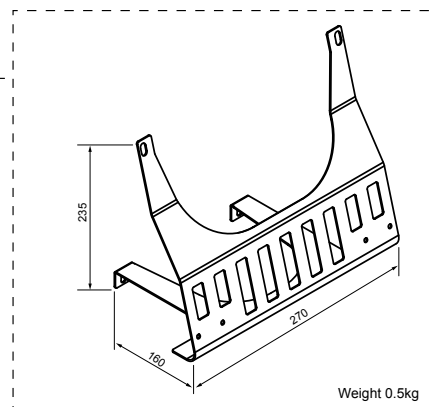

Weight 0.5kg



### Fan Kit for NUMDrive X Size 6 AGOFAN001

Accessories	Order code	Description
Fan Module	<b>AGOFAN001</b>	MDLL3120N00HN0I MDLU3400A000N0I

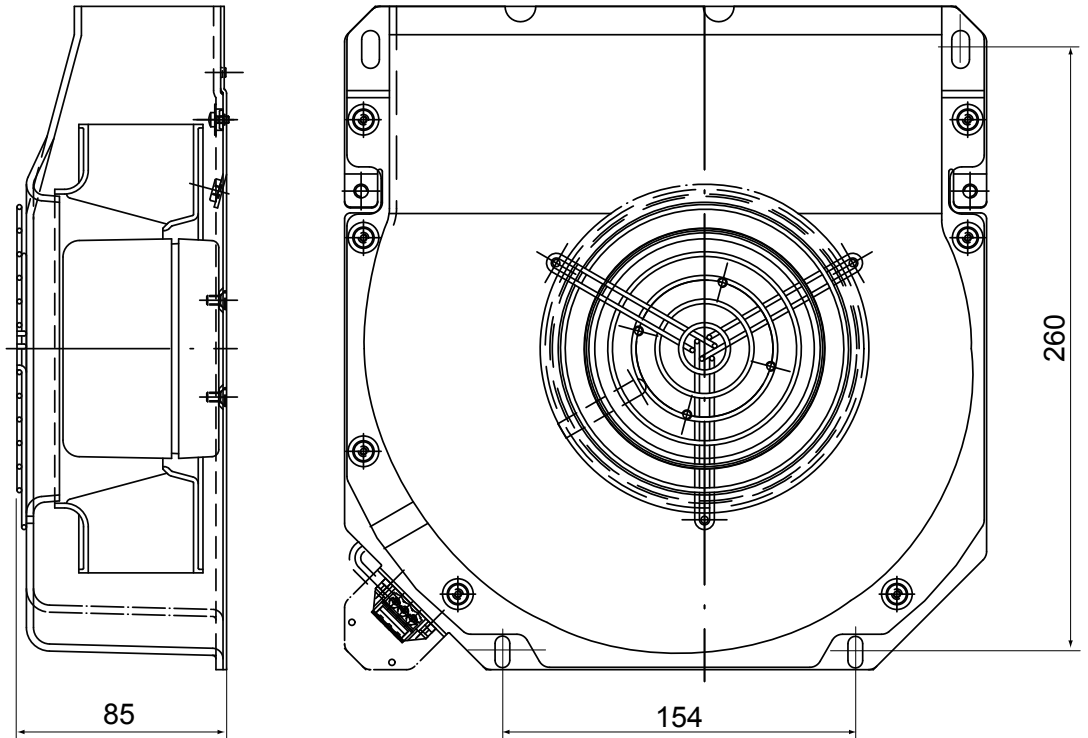



### Terminal Connections for nPad Mobile Operator Panel

Accessories	Order code	Description
Terminal Connection	<b>NPADA001</b>	Terminal connection for nPad Mobile Operator Panel. See figure.

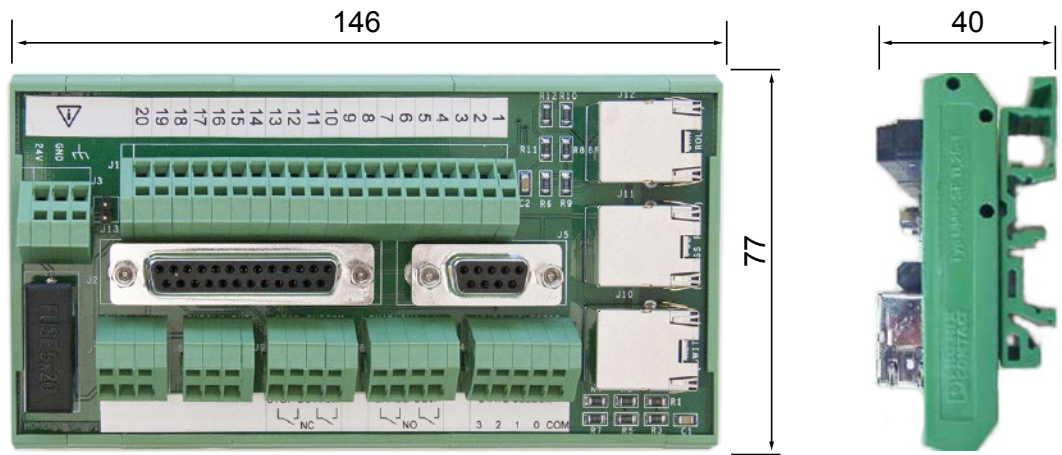

Approx. weight: 0.2kg

### Socket for Portable Handwheel HBA-X FXHE181310

Accessories	Order code	Description
Socket for Portable HBA-X	<b>FXHE181310</b>	XBA-X connector Please also refer to "Main accessories overview" section.

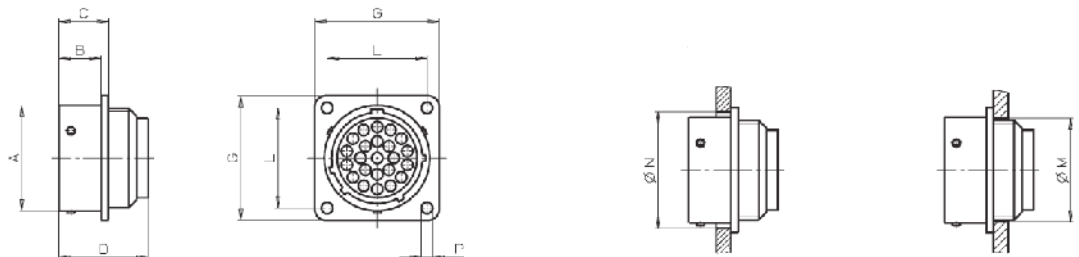
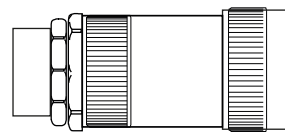



### Line Filter AGOFIL024A, 025A, 026, 027

Technical Data	AGOFIL024A	AGOFIL025A	AGOFIL026	AGOFIL027
MDLL3 Association	MDLL3015N00AN0I	MDLL3030N00AN0I	MDLL3025N00RN0I MDLL3025N00HN0I MDLL3050N00RN0I MDLL3050N00HN0I	MDLL3120N00HN0I
Rated Voltage	480 Vac 50/60 Hz			
Rated Current (refer. to 50°C amb. temp)	42 Arms	75 Arms	100 Arms	180 Arms
Test Voltage	3470 Vdc, 2s (line to ground) 1700 Vdc, 2s (line to line)			
Leakage Current	Normal condition < 3mA Fault condition 260mA (only one phase remaining)			
Approvals	EN61800-3 category C3 - I < 100mA (second environment (industrial low-voltage supply network))			
Terminal Block Cross Section: LINE/LOAD	10 mm <sup>2</sup>	16 mm <sup>2</sup>	50 mm <sup>2</sup>	95 mm <sup>2</sup>
Weight	2.8 kg	4.4 kg	4.7 kg	7.5 kg

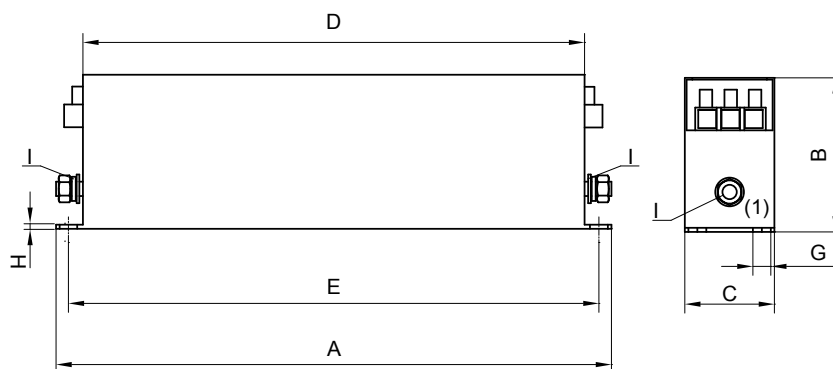

(1) Earth point connections (M6 or M10). Screw tightening torque: 1.9 - 2.1 Nm.

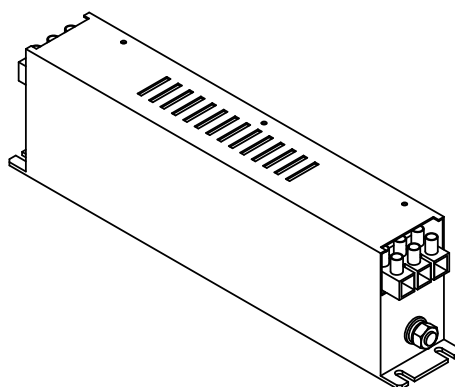

Line Filter	A	B	C	D	E	F	G	H	I
AGOFIL024A	310	85	50	280	395	30	5.4	2	M6
AGOFIL025A	270	135	80	240	255	60	6.5	3	M6
AGOFIL026	270	150	90	240	255	65	6.5	3	M10
AGOFIL027	380	170	120	350	362	102	6.5	3	M10

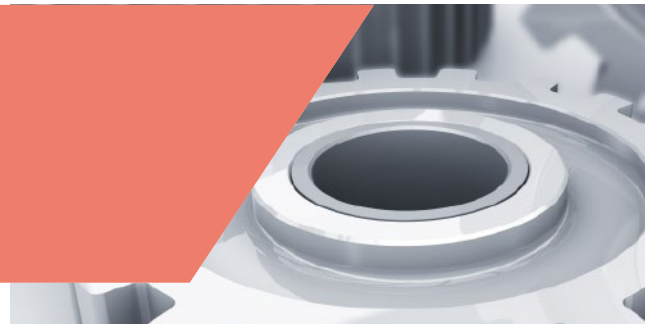

### Filter AGOFIL001S for Auxiliary Power Supply

Technical Data	AGOFIL001S
MDLL3, MDLQ Association	All MDLL3 and MDLQ power supply
Rated Voltage	440 Vac 50/60 Hz
Rated Current (refer. to 40°C amb. temp)	3 A
Test Voltage	1075 Vdc, 2s (line/line) - 2700 Vdc, 2s (line to ground)
Climatic Category	HPF 25/085/21 (-25°C/+85°C)
Approvals	UL Recognized
Terminal Cross Section	Faston 6.3 x 0.8 mm
Weight	0.3 kg

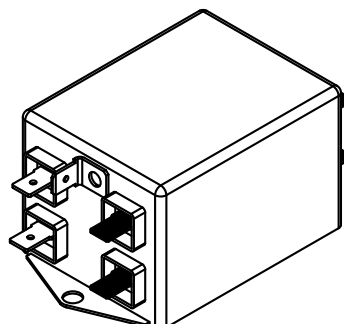
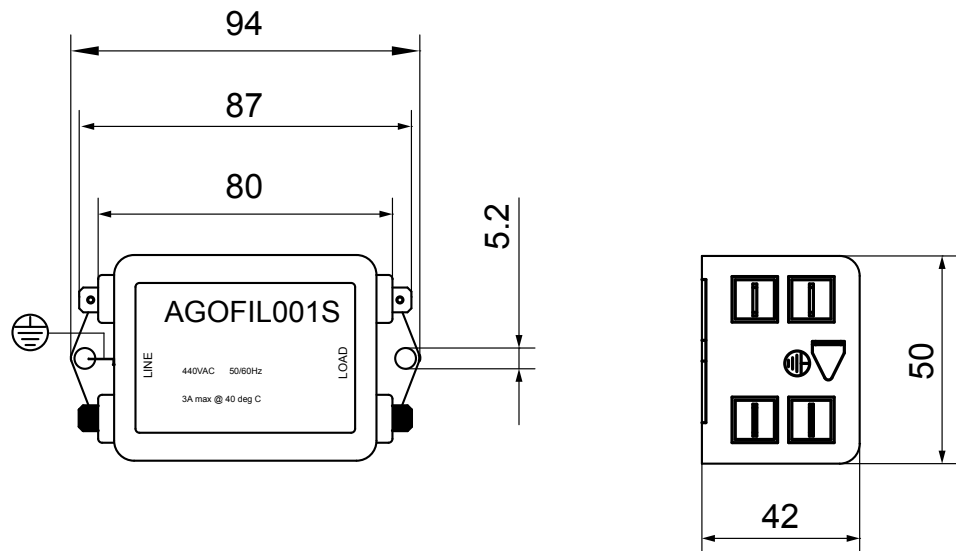
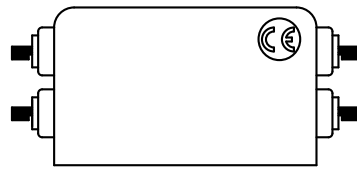



### Line Filter HPPM166

Technical Data	HPPM166
MDLL3 Association	MDLL3025N00HN0I MDLL3050N00HN0I MDLL3025N00RN0I MDLL3050N00RN0I MDLL3120N00HN0I
Rated Voltage	440 Vac 50/60 Hz
Rated Current	20 A
Capacitance	3 x 16.6 $\mu$ F
Terminal Connections	M8 bolt
Weight	1.2 kg

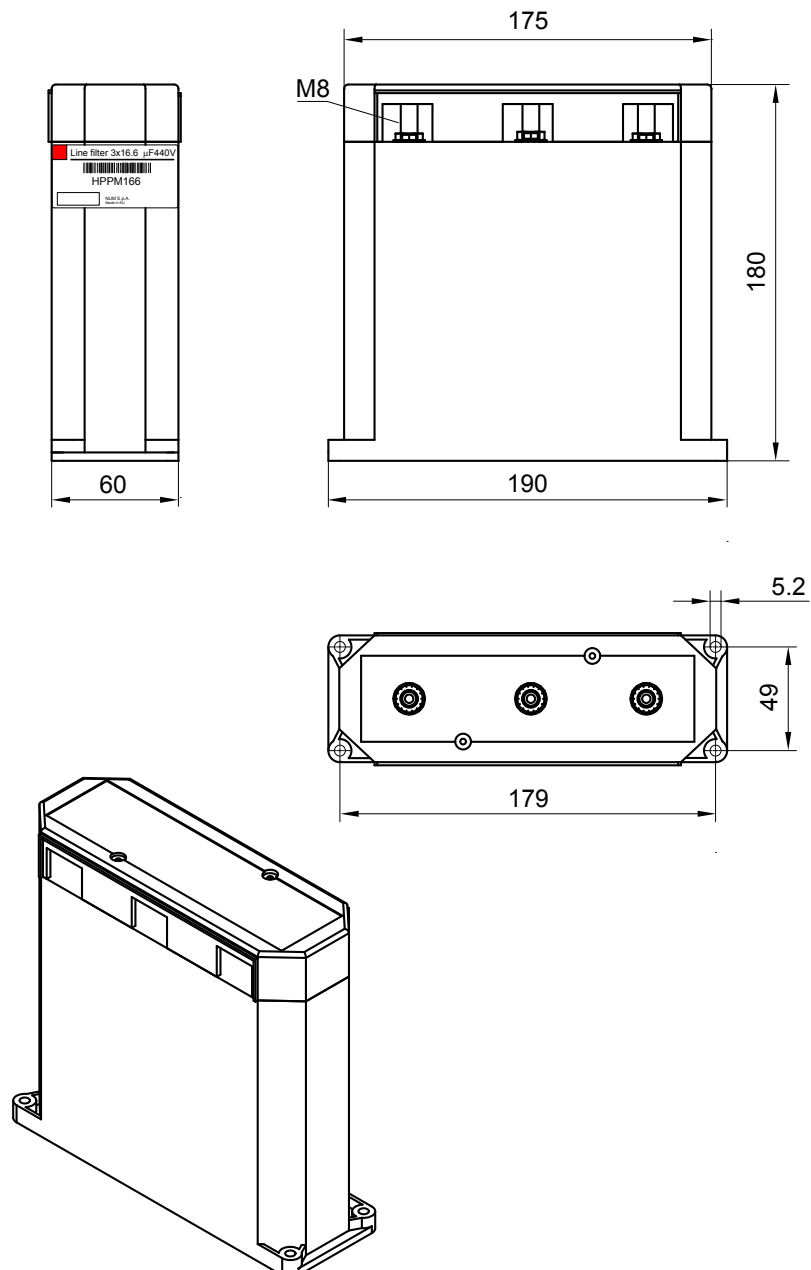



### Line Chokes

Line Choke	AGOIND001	AGOIND002	AGOIND006	AGOIND007	AGOIND009
MDLL3 Association	MDLL3025N00HN0I	MDLL3050N00HN0I	MDLL3025N00RN0I	MDLL3050N00RN0I	MDLL3120N00HN0I
Rated Voltage	67 Arms	103 Arms	60 Arms	100 Arms	210 Arms
Inductance	0.45 mH	0.27 mH	0.5 mH	0.3 mH	0.15 mH
Losses	250 W	350 W	94 W	260 W	300 W
Degree of Protection	IP00				
Weight	13 kg	18 kg	11 kg	16 k	56 kg

AGOIND001 and AGOIND002 - Overall Dimensions

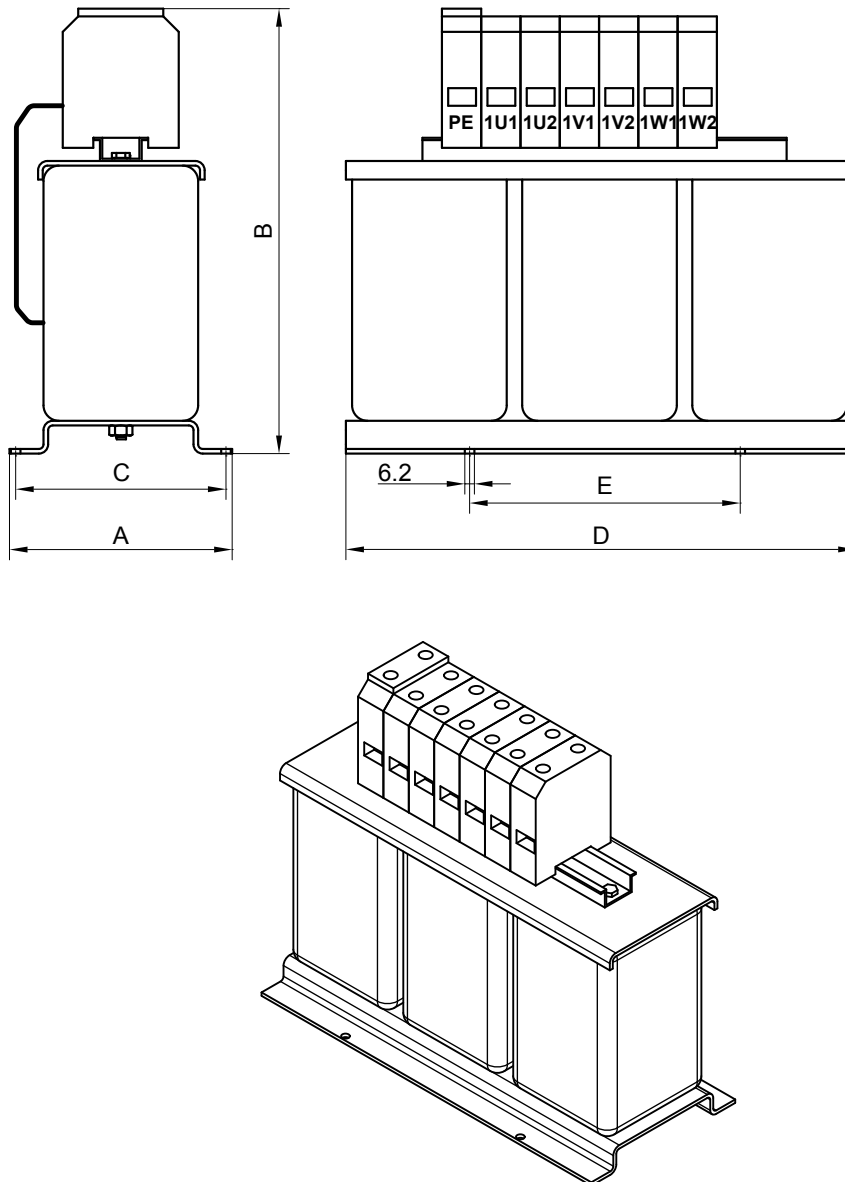

Line Choke	A	B	C	D	E	Terminal Block Cross Section
AGOIND001	150	230	136	330	175	35 mm <sup>2</sup>
AGOIND002	150	280	136	330	175	50 mm <sup>2</sup>



### Line Chokes Overall Dimensions

AGOIND006 - Overall Dimensions

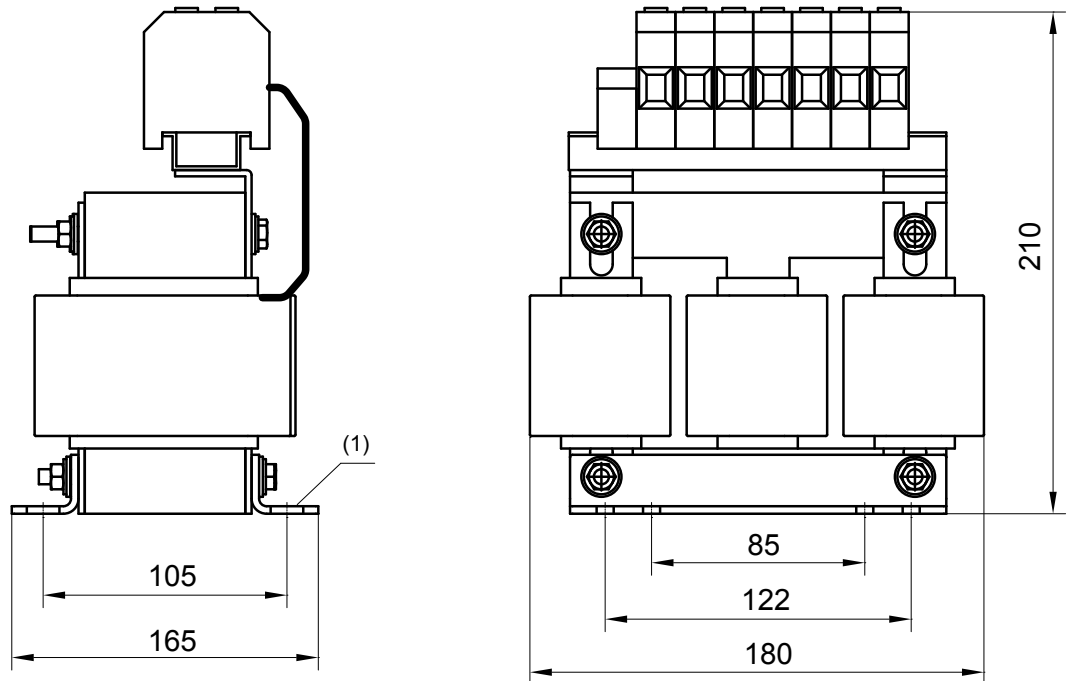

(1) 8x (Ø6x12)

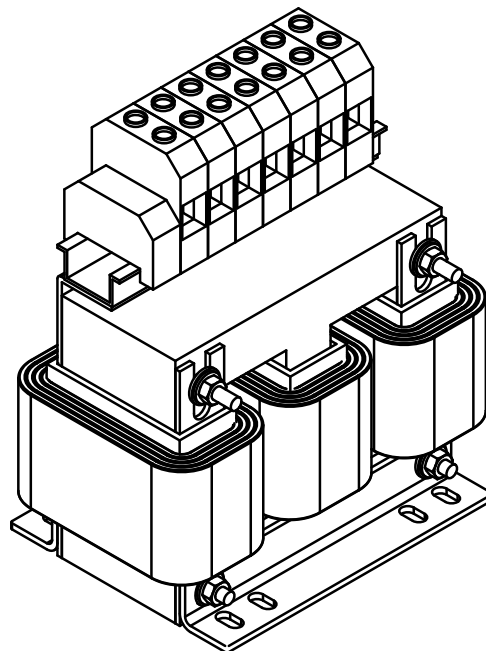



### Line Chokes Overall Dimensions

AGOIND007 - Overall Dimensions

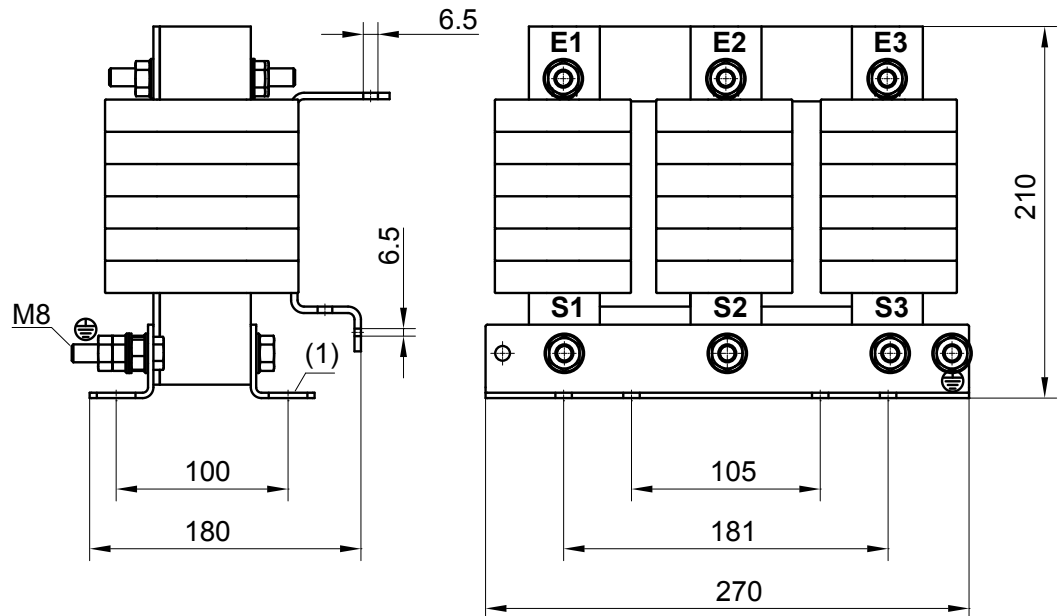

(1) 8x (Ø11x22)

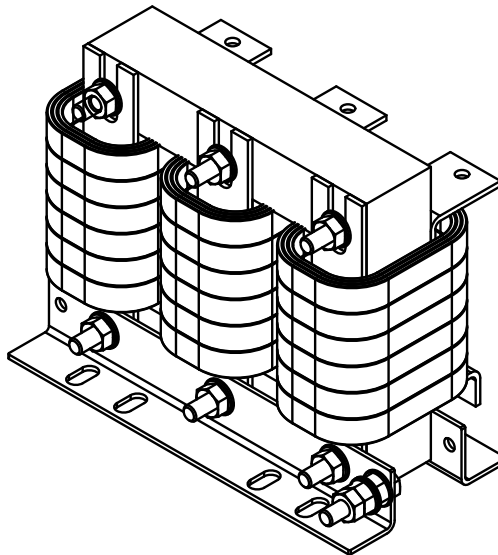



### Line Chokes Overall Dimensions

AGOIND009 - Overall Dimensions

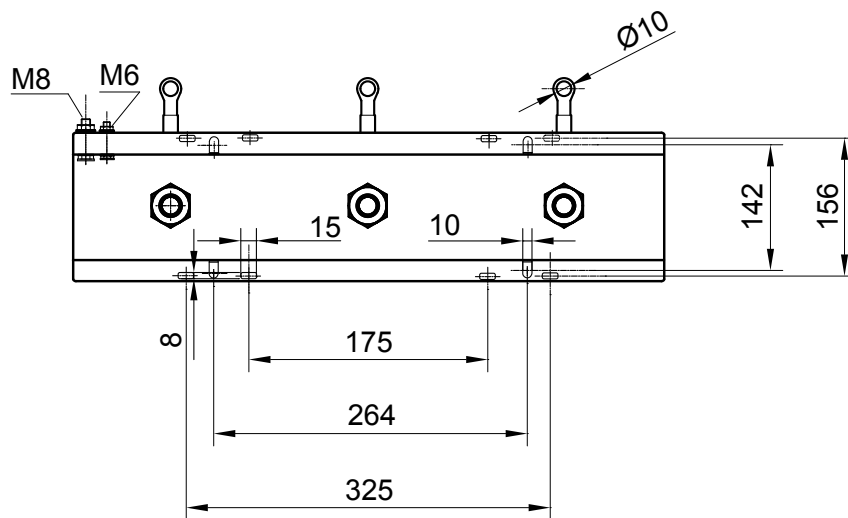
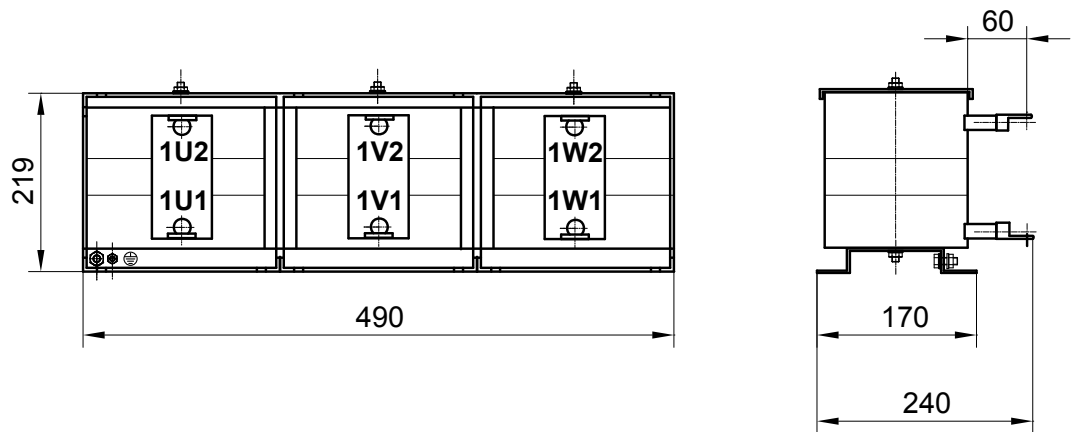

10









### Braking Resistor

External Braking Resistor	AGORES008	AGORES009	AGORES010
Continuous Nominal Power (Environment Temperature 40°C)	480 W	480 W	2500 W
Resistive Value	17 Ω	8.5 Ω	5.6 Ω
Resistor Thermal Protection by Means of Thermal Switches	- Thermal switch 1 fitted on the frame with N.C contact - Contact interruption 10A/250 Vac - Contact open >400°C for AGORES008/9 - Contact open >160 °C for AGORES010		
Energy Pulse <500ms	12 kJ	12 kJ	125 kJ
Weight	0.35 kg	0.35 kg	5.6 kg

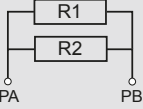

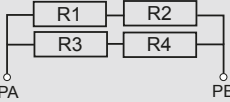
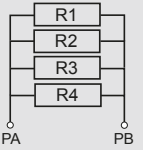
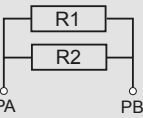
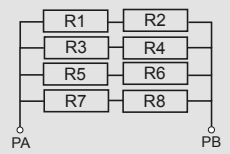
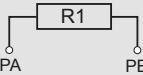
### Braking Resistor Operating Examples

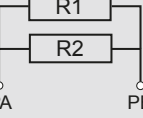
MDLL3 Association	Braking Resistor	Connection Configuration	Value [ $\Omega$ ]	P cont. [W]	Peak Power <100ms [kW]
MDLL3015N00AN0I	<b>AGORES008</b>		17	480W	30kW
	<b>AGORES008 (X4)</b>			1920W	30kW
MDLL3030N00AN0I MDLL3025N00RN0I MDLL3025N00HN0I	<b>AGORES008 (X2)</b>		8.5	960W	61kW
	<b>AGORES009</b>			480W	61kW
	<b>AGORES009 (X4)</b>			1920W	61kW
MDLL3050N00RN0I MDLL3050N00HN0I	<b>AGORES008 (X4)</b>		4.25	1920W	120kW
	<b>AGORES009 (X2) Basic Configuration</b>			960W	120kW
	<b>AGORES009 (X8)</b>			3840W	120kW
	<b>AGORES010</b>			5.6	2500W
MDLL3120N00HN0I	<b>AGORES010</b>		5.6	2500W	100kW (Peak power <1s)
	<b>AGORES010 (X2)</b>		2.8	5000W	200kW (Peak power <1s)

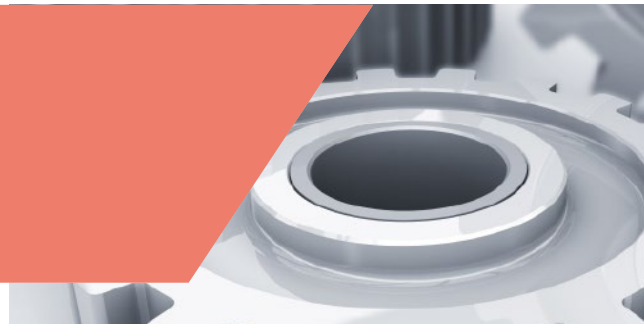

### Braking Resistor Overall Dimensions

AGORES008, AGORES009 - Overall Dimensions

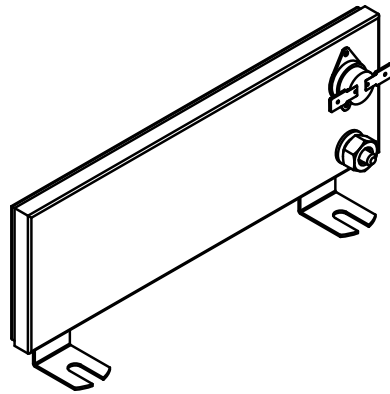
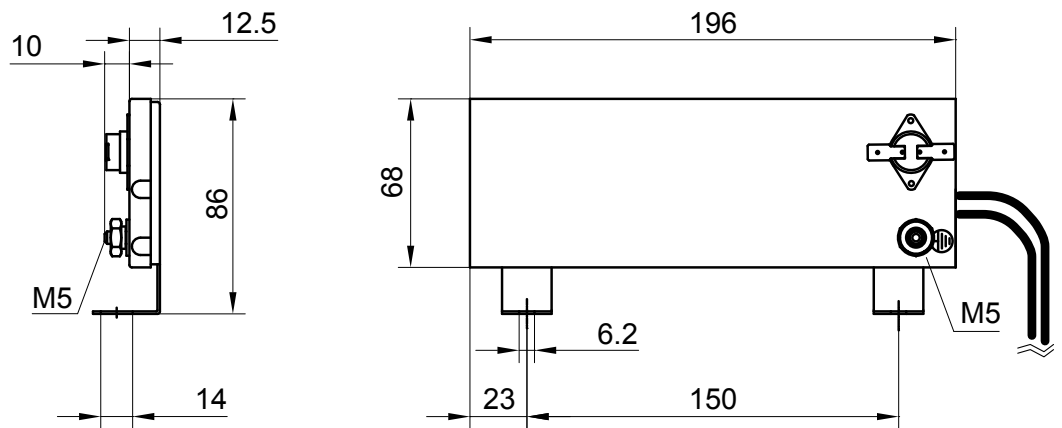



### Braking Resistor Overall Dimensions

AGORES010 - Overall Dimensions

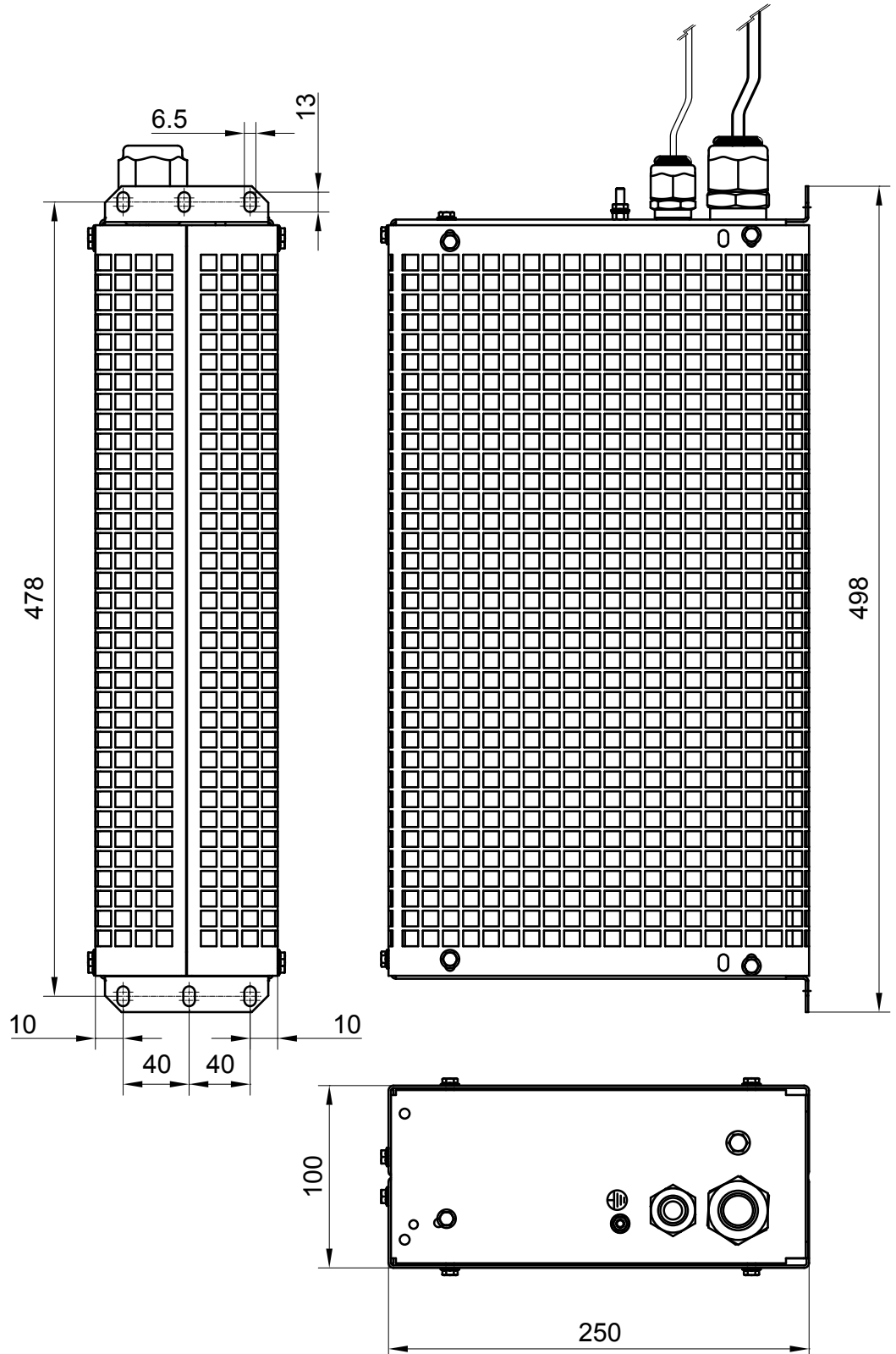

10

## Auto-Transformer



### Auto-Transformer for BHL260 Fan (with 460V Network)

Technical Data	AMOTRAF001
Rated Power	500 VA
Input Voltage	400 Vac / 480 Vac 3phases
Frequency	50/60 Hz
Protection Class as per EN60529	IP00
Weight	2.8 kg

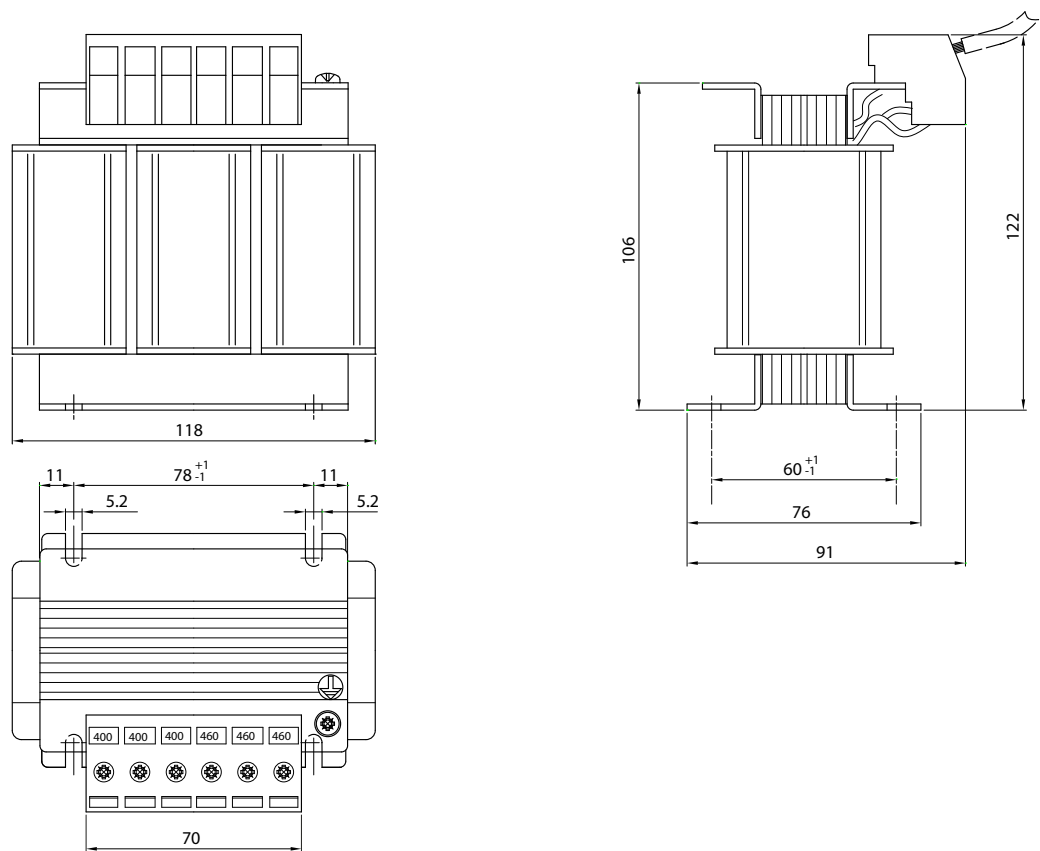



### Motor Cables

The cables are available with different conductor sizes, characteristics and compositions. Options include High Performance and Basic Performance power cables, as well as combined power/sensor cables for use with SHX and SPX motors.

The cables comply with with UL and cUL recognized, DESINA and EC standards:

- Multi-strand conductors provide flexibility for movement
- The motor thermal probe is connected by the sensor motor cable
- The brake is connected by the power cable
- The connection between the power / sensor cable and the moving part of the connector must be made using the crimping tool

### High Performance Power Cables

Cable Code	Brake Wires	Cable Composition	External Diameter (mm)
PC015BH00	Yes	[(3+T) x 1.5 mm <sup>2</sup> + (2x1.5 mm <sup>2</sup> )]	11.8 ± 0.5
PC040BH00	Yes	[(3+T) x 4 mm <sup>2</sup> + (2x1.5 mm <sup>2</sup> )]	14.4 ± 0.6
PC060BH00	Yes	[(3+T) x 6 mm <sup>2</sup> + (2x1.5 mm <sup>2</sup> )]	16.3 ± 0.7
PC100BH00	Yes	[(3+T) x 10 mm <sup>2</sup> + (2x1.5 mm <sup>2</sup> )]	19.2 ± 0.8
PC215BH00	Yes	[(3+T) x AWG04 + (2x1.5 mm <sup>2</sup> )]	24.7 ± 0.9
PC015NH00	No	[(3+T) x 1.5 mm <sup>2</sup> ]	10.6 ± 0.5
PC040NH00	No	[(3+T) x 4 mm <sup>2</sup> ]	13.2 ± 0.6
PC100NH00	No	[(3+T) x 10 mm <sup>2</sup> ]	18.1 ± 0.8

<b>Operating Temperature</b>	-30°C ... to + 80°C
<b>Storage Temperature</b>	-50°C ... to + 80°C
<b>Nominal Voltage</b>	Power: U <sub>0</sub> /U = 0.6/1KV (VDE), U = 1000V (UL AWM/CSA AWM), Brake U = 24V (VDE)
<b>Bending Radius (Dynamic)</b>	≥ 7.5 x external diameter
<b>Bending Radius (Static)</b>	≥ 4 x external diameter
<b>Maximum Speed</b>	300 m/min
<b>Maximum Acceleration</b>	50 m/sec <sup>2</sup>
<b>Cycles</b>	10.000.000
<b>Torsion max</b>	+/- 30°/m
<b>Pulling Force (Dynamic)</b>	≤ 20 N/mm <sup>2</sup>
<b>Pulling Force (Static)</b>	≤ 50 N/mm <sup>2</sup>
<b>Capacitance [pF/m] Power</b>	
- Conductor/Conductor	sec. 1.5-2.5 mm <sup>2</sup> <90 (Typical 80), sec. 4.0-6.0 mm <sup>2</sup> <110 (Typical 90)
- Conductor/Shield	<160 (Typical 130), <180 (Typical 140)
<b>Capacitance [pF/m] Brake</b>	
- Conductor/Conductor	sec. 1.5 mm <sup>2</sup> <120 (Typical 100)
- Conductor/Shield	<200 (Typical 170)
<b>Oil Resistant</b>	HD 22.10 S2 (VDE 0282 p.10)//VDE 0472 p.803 B//EN 60811.2.1
<b>Flame Resistant</b>	EN 60332-1-1 // EN 60332-1-3 // FT// UL 1581 sec.1061//EN 50265.2.1
<b>UL/CSA LISTED, DESINA</b>	Yes
<b>Jacket Colour</b>	PUR - Orange - RAL2003
<b>Resistivity of Cable at 20°C [Ohm/km]</b>	1.5 mm <sup>2</sup> = 13.3, 4 mm <sup>2</sup> = 4.95, 6 mm <sup>2</sup> = 3.3, 10 mm <sup>2</sup> = 1.91, 21 mm <sup>2</sup> = 0.83
<b>Max Useful Length</b>	75 m



### Basic Performance Power Cables

NUM Basic Performance cables are normally used where high flexibility is not strictly required.

Cable Code	Brake Wires	Cable Composition	External Diameter (mm)
PC015BL00	Yes	((3+T) x 1.5 mm <sup>2</sup> + (2x1.5 mm <sup>2</sup> ))	10.4 ± 0.4
PC040BL00	Yes	((3+T) x 4 mm <sup>2</sup> + (2x1.5 mm <sup>2</sup> ))	13 ± 0.5
PC015NL00	No	((3+T) x 1.5 mm <sup>2</sup> )	8.1 ± 0.4
PC040NL00	No	((3+T) x 4 mm <sup>2</sup> )	11.0 ± 0.5

<b>Operating Temperature</b>	-10°C ... to + 80°C
<b>Storage Temperature</b>	-20°C ... to + 80°C
<b>Nominal Voltage</b>	- Power : U <sub>0</sub> /U = 0.6/1KV (VDE) - U = 1000 V (UL AWM/CSA AWM) - Brake U = 24 V (VDE)
<b>Bending Radius (Dynamic)</b>	≥ 15 x external diameter
<b>Bending Radius (Static)</b>	≥ 5 x external diameter
<b>Maximum Speed</b>	30 m/min
<b>Maximum Acceleration</b>	2 m/sec <sup>2</sup>
<b>Cycles</b>	2.000.000
<b>Torsion max</b>	Not admitted
<b>Pulling Force (Dynamic)</b>	≤ 20 N/mm <sup>2</sup>
<b>Pulling Force (Static)</b>	≤ 50 N/mm <sup>2</sup>
<b>Capacitance [pF/m] Power</b>	
- Conductor/Conductor	sec. 1.5-2.5 mm <sup>2</sup> <90 (Typical 80), sec. 4.0-6.0 mm <sup>2</sup> <110 (Typical 90)
- Conductor/Shield	<160 (Typical 130), <180 (Typical 140)
<b>Capacitance [pF/m] Brake</b>	
- Conductor/Conductor	sec. 1.5 mm <sup>2</sup> <120 (Typical 100)
- Conductor/Shield	<200 (Typical 170)
<b>Oil Resistant</b>	VDE 0472 p.803 B//EN 60811.2.1
<b>Flame Resistant</b>	EN 60332-1-1 // EN 60332-1-3 // FT1// UL 1581 sce.1061//EN 50265.2.1
<b>UL/CSA LISTED, DESINA</b>	Yes
<b>Jacket Colour</b>	Thermoplastic compound - Orange - RAL2003
<b>Resistivity of Cable at 20°C [Ohm/km]</b>	- 1.5 mm <sup>2</sup> = 13.3, 4 mm <sup>2</sup> = 4.95
<b>Max Useful Length</b>	75 m



### High Performance Cable for SHX and SPX Motors (Single Motor Cable)

High Performance motor cable for SHX and SPX motors contains:

- 3x power wires
- Ground wire
- 2x Brake wires
- 2x Encoder wires

Cable Code	Brake Wires	Cable Composition	External Diameter (mm)
PS015xH00	Yes	([3+T] x 1.5 mm <sup>2</sup> + 2x1.5 mm <sup>2</sup> + 2 x AWG22)	13.2 ± 0.5

<b>Operating Temperature</b>	-30°C ... to + 80°C
<b>Storage Temperature</b>	-40°C ... to + 80°C
<b>Nominal Voltage</b>	- Power : U <sub>o</sub> /U = 0.6/1KV (VDE) - Brake U = 24 V (VDE)
<b>Bending Radius (Dynamic)</b>	≥ 7.5 x external diameter
<b>Bending Radius (Static)</b>	≥ 5 x external diameter
<b>Maximum Speed</b>	300 m/min
<b>Maximum Acceleration</b>	50 m/sec <sup>2</sup>
<b>Cycles</b>	10.000.000
<b>Torsion max</b>	+/- 30°/m
<b>Pulling Force (Dynamic)</b>	≤ 20 N/mm <sup>2</sup>
<b>Pulling Force (Static)</b>	≤ 50 N/mm <sup>2</sup>
<b>Capacitance [pF/m] Power</b>	
- Conductor/Conductor	<90 (Typical 80)
- Conductor/Shield	<160 (Typical 130)
<b>Capacitance [pF/m] Brake</b>	
- Conductor/Conductor	<120 (Typical 100)
- Conductor/Shield	<200 (Typical 170)
<b>Encoder Data Pair</b>	
- Capacitance [pF/m nom. (cc)]	46
- Impedance [Ohms]	110 ± 15% (1MHz)
<b>Oil Resistant</b>	HD 22.10 S2 (VDE 0282 p.10) // VDE 0472 p.803 B // EN 60811.2.1
<b>Flame Resistant</b>	EN 60332-1-1 // EN 60332-1-3 // FT1// UL 1581 sce.1061 // EN 50265.2.1
<b>UL/CSA LISTED, DESINA</b>	Yes
<b>Jacket Colour</b>	PUR - Orange - RAL2003
<b>Resistivity of Cable at 20°C [Ohm/km]</b>	1.5 mm <sup>2</sup> = 13.3
<b>Max useful Length</b>	75 m



### Sensor Cable

Cable Code	Cable Composition	External Diameter (mm)
SC007SH00	(3x (2x 0.14 mm <sup>2</sup> ) + 4x 0.14 mm <sup>2</sup> + 2x 0.50 mm <sup>2</sup> )	8.5 ± 0.3
<b>Operating Temperature</b>	-20°C ... to + 60°C	
<b>Storage Temperature</b>	-50°C ... to + 60°C	
<b>Nominal Voltage</b>	UL AWM – CSA AWM U = 30 V	
<b>Bending Radius (Dynamic)</b>	≥ 70 x external diameter	
<b>Bending Radius (Static)</b>	≥ 40 x external diameter	
<b>Maximum Speed</b>	300 m/min	
<b>Maximum Acceleration</b>	50 m/sec <sup>2</sup>	
<b>Cycles</b>	10.000.000	
<b>Torsion max</b>	+/- 30°/m	
<b>Pulling Force (Dynamic)</b>	≤ 20 N/mm <sup>2</sup>	
<b>Pulling Force (Static)</b>	≤ 50 N/mm <sup>2</sup>	
<b>Capacitance [pF/m]</b>	≤ 80 +/- 20	
<b>Oil Resistant</b>	HD 22.10 S2 (VDE 0282 p.10)	
<b>Flame Resistant</b>	EN 60332-1-1 // EN 60332-1-3 // FT1	
<b>UL/CSA LISTED, DESINA</b>	Yes	
<b>Jacket Colour</b>	Green - RAL6018	
<b>Resistivity of Cable at 20°C [Ohm/km]</b>	0.14 mm <sup>2</sup> = 134, 0.50 mm <sup>2</sup> = 39	
<b>Max Useful Length</b>	75 m	

### Fan Cable for BHL and AMS Motors

Cable Code	Cable Composition	External Diameter (mm)
NC010NL00	([3+T] x1,5 mm <sup>2</sup> (not shielded))	8 ± 0.2



### Raw Cable Ordering Codes

#### Raw Power Cable Ordering Code \*

	<b>PC</b>	<b>015</b>	<b>B</b>	<b>H</b>	<b>0</b>	<b>0</b>
<b>Cable Type</b>						
- Power Cable						
<b>Cable Section</b>						
- Cable Section 1.5 mm <sup>2</sup>		015				
- Cable Section 4 mm <sup>2</sup>		040				
- Cable Section 10 mm <sup>2</sup>		100				
<b>Brake</b>						
- With Brake			B			
- Without Brake			N			
<b>Application</b>						
- High Performance				H		
- Basic Performance				L		
<b>Cable Alone</b>						
- Fixed Value					0	0

#### Raw Sensor Cable Ordering Code \*

	<b>SC</b>	<b>007</b>	<b>S</b>	<b>H</b>	<b>0</b>	<b>0</b>
<b>Cable Type</b>						
- Sensor Cable						
<b>Identification Number</b>						
<b>Variant</b>						
<b>Application</b>						
- High Performance				H		
<b>Cable Alone</b>						
- Fixed Value					0	0

#### Other Raw Cable Ordering Code \*

	<b>NC</b>	<b>010</b>	<b>N</b>	<b>L</b>	<b>0</b>	<b>0</b>
<b>Cable Type</b>						
- Others Cable						
<b>Identification Number</b>						
<b>Variant</b>						
<b>Application</b>						
- Basic Performance				L		
<b>Cable Alone</b>						
- Fixed Value					0	0

\* Note: the required length of raw cable (max 75 m) is specified as 'quantity' in the order.

### Ordering Raw Cable - Example

Cable Code Example	Raw Cable Length Definition
PC015BH00 "Quantity" 50 m	The raw cable length is defined as 'quantity' in the order. In this case the raw power + brake cable length is 50 m.



### Power Assembly Cable Ordering Code

	PC	015	B	H	0	0	M	000	0
<b>Cable Type</b>									
- Power Cable									
<b>Cable Section</b>									
- Cable Section 1.5 mm <sup>2</sup>		015							
- Cable Section 4 mm <sup>2</sup>		040							
- Cable Section 10 mm <sup>2</sup>		100							
<b>Brake</b>									
- With Brake			B						
- Without Brake			N						
<b>Application</b>									
- High Performance				H					
- Basic Performance				L					
<b>Motor Connector</b>									
- Without connector					0				
- AMOCON004D					4				
- AMOCON005D					5				
<b>Drive Connector</b>									
- Without connector						0			
- AEOCON009						1			
- AEOCON013						2			
<b>Cable Assembly</b>									
<b>Cable Length</b>									
- Meter (m)									
<b>Cable Length</b>									
- 0.1 meter (dm)									

Note:

- The max cable length is 75 m
- Not all combinations of cable/connector couplings are possible

Power and brake cable





### Sensor Assembly Cable Ordering Code

	SC	007	S	H	0	0	M	000	0
<b>Cable Type</b>									
- Sensor Cable									
<b>Identification number</b>									
<b>Variant</b>									
<b>Application</b>									
- High Performance				H					
<b>Motor Connector</b>									
- Without connector						0			
- CONN125D00						1			
- AMOCON002D						2			
<b>Drive Connector</b>									
- Without connector							0		
- AEOCON012 <sup>1</sup>							3		
- AEOCON012 (Reverse cable output) <sup>2</sup>							4		
<b>Cable Assembly</b>									
<b>Cable Length</b>									
- Meter (m)									
<b>Cable Length</b>									
- 0.1 meter (dm)									

<sup>1</sup> Suggested for coupling on: NUMDrive C (X1,X2)

<sup>2</sup> Suggested for coupling on: MDLUX (X1,X2,X3,X4), NUMDrive C (X3,X4)

#### Note:

- The max cable length is 75 m
- Not all combinations of cable/connector couplings are possible

#### Sensor cable





### Single Motor Cable Assembly (for SHX and SPX Motors) Ordering Code

	PS	015	B	H	6	0	M	000	0
<b>Cable Type</b>									
- Power / Sensor Cable									
<b>Cable Section</b>									
- Defined on 0.1 mm <sup>2</sup>									
<b>Brake</b>									
- With brake			B						
<b>Application</b>									
- High Performance				H					
<b>Motor Connector</b>									
- AMOCON006D					6				
<b>Drive Connector</b>									
- Without connector						0			
- AEOCON009						1			
- AEOCON013						2			
<b>Cable Assembly</b>									
<b>Cable Length</b>									
- Meter (m)									
<b>Cable Length</b>									
- 0.1 meter (dm)									

Note:

- The max cable length is 75 m
- Not all combinations of cable/connector couplings are possible
- Whenever the drive connector is not required add 50 cm of cable for the encoder connections

Encoder cable (power/sensor)





### Fan Assembly Cable (for AMS, BHL Motors) Ordering Code

	NC	010	N	L	0	0	M	000	0
<b>Cable Type</b>									
- Fan Cable									
<b>Identification number</b>									
<b>Variant</b>									
<b>Application</b>									
- Basic Performance				L					
<b>Motor Connector</b>									
- CONN113D00						7			
<b>Drive Connector</b>									
- Without connector							0		
<b>Cable Assembly</b>									
<b>Cable Length</b>									
- Meter (m)									
<b>Cable Length</b>									
- 0.1 meter (dm)									

Fan cable





### BHX and BPX Connectors, Cables and Cable Assemblies

BHX / BPX	Connectors		Cable		Cable Assemblies <sup>1</sup>	
	Power	Sensor	Power	Sensor	Power	Sensor
0551V5... <sup>2</sup>	AMOCON004D	AMOCON002D	PC015xy00	SC007SH00	PC015xy4zMnnnn	SC007SH2wMnnnn
0751V5...						
0752V5...						
0951V5...						
0952N5...						
0952V5...						
1261N5...						
1261V5...						
1262N5...						
1262V5...						
1263N5...						
1263R5...						
1552N5...						
1552R5...						
1554N5...						

<sup>1</sup> Note for the cable assemblies:

x: cable with or without brake wires

x = B for cable with brake wires

x = N for cable without brake wires

y: cable performance

y = H for High performance cable

y = L for Basic performance cable

z: power connector on drive side

z = 0 without connector

z = 1 with connector AEOCON009

z = 2 with connector AEOCON013

w: sensor connector on drive side

w = 0 without connector

w = 3 with connector AEOCON012

w = 4 with connector AEOCON012 reversed

nnnn = cable length in 0.1 m

nnnn = 0105 = 10.5 m

<sup>2</sup> Available as BPX only



### SHX and SPX Connectors, Cables and Cable Assemblies

SHX / SPX	Motor Connector	Cable	Cable Assemblies <sup>1</sup>
0751V5...	AMOCON006D	PS015BH00	PS015BH6zMnnnn
0752V5...			
0951V5...			
0952N5...			
0952V5...			
1261N5...			
1261V5...			
1262N5...			
1262V5...			
1263R5...			
1552N5...			
1552R5...			
1554N5...			

<sup>1</sup> Note for the cable assemblies:

z: power connector on drive side

z = 0 without connector

z = 1 with connector AEOCON009

z = 2 with connector AEOCON013

n n n n = cable length in 0.1 m

n n n n = 0105 = 10.5 m

# Cables / Accessories

## Motor Cables and Connectors



### BPH Connectors, Cables and Cable Assemblies

BPH	Connectors		Cable		Cable Assemblies <sup>1</sup>	
	Power	Sensor	Power	Sensor	Power	Sensor
0751N5...	AMOCON004D		PC015xy00		PC015xy4zMnnnn	
0751V5...						
0752N5...						
0752V5...						
0754N5...						
0952N5...						
0952V5...						
0953N5...						
0953V5...						
0955N5...						
1152N5...						
1152V5...						
1153K5...						
1153N5...						
1153V5...						
1154K5...						
1154N5...						
1154V5...						
1156N5...						
1422K5...			AMOCON002D			
1422N5...						
1422R5...						
1423K5...						
1423N5...						
1423R5...						
1424K5...						
1424N5...						
1424R5...						
1427N5...						
1902K5...	AMOCON005D		PC040xy00		PC040xy4zMnnnn	
1902N5...						
1902R5...						
1903K5...						
1903N5...						
1904K5...						
1904N5...						
1905H5...						
1905L5...						
1907K5...						
1907N5...						
190AK5...						

<sup>1</sup> See page 248 for cable assembly notes

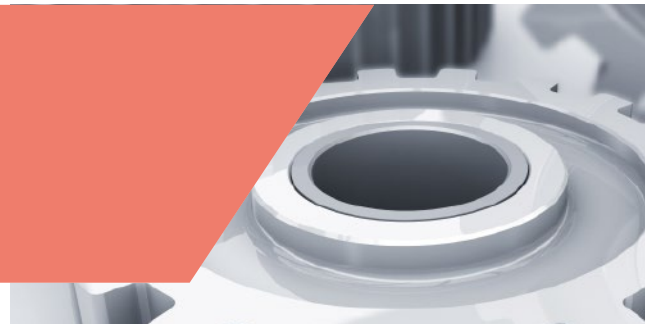

### BPG Connectors, Cables and Cable Assemblies

BPG	Connectors		Cable		Cable Assemblies <sup>1</sup>	
	Power	Sensor	Power	Sensor	Power	Sensor
0751N5...	AMOCON004D	AMOCON002D	PC015Ny00	SC007SH00	PC015Ny4zMnnnn	SC007SH2wMnnnn
0752N5...						
0952N5...						
0953N5...						
1152N5...						
1153K5...						
1153N5...						
1153V5...						
1422N5...						
1423N5...						
1424K5...						
1424R5...						
1427N5...						
1902K5...						
1902N5...						
1903K5...	AMOCON005D		PC040Ny00		PC040Ny4zMnnnn	
1903N5...						
1904N5...						
1905L5...			PC100Ny00		PC100Ny5zMnnnn	

<sup>1</sup> Note for the cable assemblies:

x: cable with or without brake wires

x = B for cable with brake wires

x = N for cable without brake wires

y: cable performance

y = H for High performance cable

y = L for Basic performance cable

z: power connector on drive side

z = 0 without connector

z = 1 with connector AEOCON009

z = 2 with connector AEOCON013

w: sensor connector on drive side

w = 0 without connector

w = 3 with connector AEOCON012

w = 4 with connector AEOCON012 reversed

nnnn = cable length in 0.1 m

nnnn = 0105 = 10.5 m



### BHL Connectors, Cables and Cable Assemblies

BHL	Connectors			Cables		
	Power	Sensor	Fan	Power	Sensor	Fan
2601N5...	AMOCON005D	AMOCON002D	CONN113D00	PC100xH00	SC007SH00	NC010NL00
2601N1...	None			PC215BH00		
2602K5...	AMOCON005D			PC100xH00		
2602K1...	None			PC215BH00		

BHL	Cable Assemblies <sup>1</sup>			High-Strength Cable Gland
	Power	Sensor	Fan	
2601N5...	PC100xH50Mnnnn	SC007SH2wMnnnn	NC010NL70Mnnnn	None
2601N1...	PC215BH00			BMHQPRE3
2602K5...	PC100xH50Mnnnn			None
2602K1...	PC215BH00			BMHQPRE3

<sup>1</sup> Note for the cable assemblies:

x: cable with or without brake wires

x = B for cable with brake wires

x = N for cable without brake wires

y: cable performance

y = H for High performance cable

y = L for Basic performance cable

z: power connector on drive side

z = 0 without connector

z = 1 with connector AEOCON009

z = 2 with connector AEOCON013

w : sensor connector on drive side

w = 0 without connector

w = 3 with connector AEOCON012

w = 4 with connector AEOCON012 reversed

nnnn = cable length in 0.1 m

nnnn = 0105 = 10.5 m



### AMS and IM18 Connectors, Cables and Cable Assemblies

AMS	Connectors		High-Strength Cable Gland	Cable			Cable Assemblies <sup>1</sup>				
	Sensor	Fan		Power	Sensor	Fan	Sensor	Fan <sup>2</sup>			
100SB1...	CONN125D00	CONN113D00	BMHQPRE2	PC060BH00	SC007SH00	NC010NL00	SC007SH1wMnnnn	NC010NL70Mnnnn			
100MB1...											
100GB1...											
100SD1...											
100MD1...											
100GD1...											
132SA1...									BMHQPRE3	PC100BH00	
132SC1...											
132SE1...											
132MA1...											
132MC1...											PC215BH00
132ME1...											
132LA1...											
132LE1...											
132SF1...											
132SG1...											
132SH1...											
132MF1...											
132MG1...											
132MH1...											
132LF1...											
132LI1...											
132LH1...											
160MA1...			2 x BMHQPRE3	2 x PC215BH00							
160MB1...											
160MC1...											
160LA1...											
160LB1...											
160LC1...											

IM	Connectors		High-Strength Cable Gland	Cable			Cable Assemblies <sup>1</sup>	
	Sensor	Fan		Power	Sensor	Fan	Sensor	Fan <sup>2</sup>
18MK14...	AMOCOCON002D	CONN114D00	2 x M50	2 x (4x25 mm <sup>2</sup> )	SC007SH00	2x1 mm <sup>2</sup>	SC007SH2wMnnnn	-

<sup>1</sup> Note for the cable assemblies:

w: sensor connector on drive side

w = 0 without connector

w = 3 with connector AEOCON012

w = 4 with connector AEOCON012 reversed

nnnn = cable length in 0.1 m

nnnn = 0105 = 10.5 m

<sup>2</sup> Only the motor connector is present and assembled



### Motor Connectors Description

Accessories	Order Code	Description	
Motor Sensor Connector	<b>AMOCON002D</b>	17 pole connector	
Motor Power Connector	<b>AMOCON004D</b>	6 pole connector	
Motor Power Connector	<b>AMOCON005D</b>	6 pole connector	
Motor Power / Encoder Connector	<b>AMOCON006D</b>	9 pole connector	
Motor Fan Connector	<b>CONN113D00</b>	5 pole connector	
Motor Fan Connector	<b>CONN114D00</b>	2 pole connector	
Motor Sensor Connector	<b>CONN125D00</b>	23 pole connector	
Power Cable Gland	<b>BMHQPRE2</b>	High-Strength Cable gland Pg 21	
Power Cable Gland	<b>BMHQPRE3</b>	High-Strength Cable gland Pg 29	

# Flexium+ Configurations

## Table of Contents

	Page
<b>Standard Configuration Flexium+ 6 and Flexium+ 8 System</b>	<b>257</b>
<b>Standard Configuration of Flexium+ 68 System</b>	<b>258</b>
<b>Multi-Panel Configuration of Flexium+</b>	<b>259</b>
<b>Flexium+ Configuration for Office PC</b>	<b>260</b>
<b>Flexium+ Configuration with Foreign Panel</b>	<b>261</b>

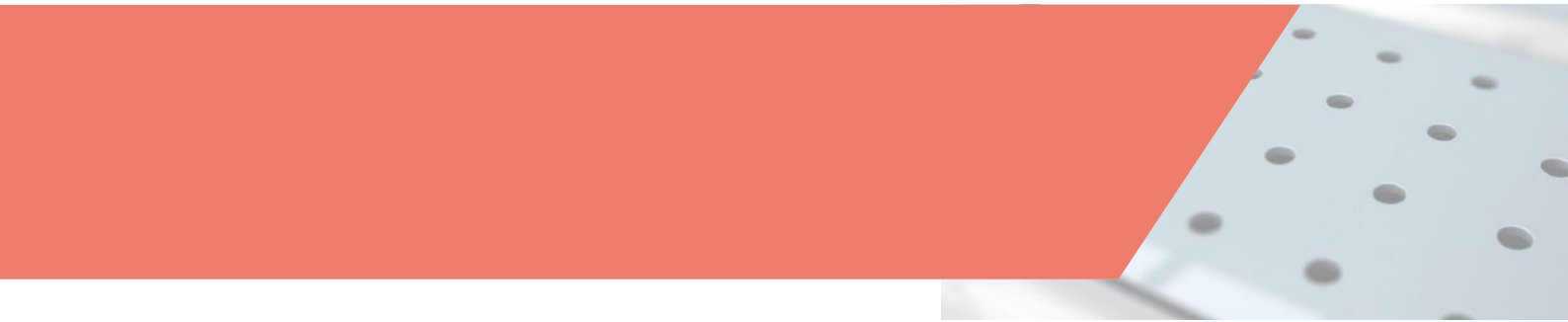

# Flexium+ Configurations

## Standard Configuration Flexium+ 6 and Flexium+ 8 System

### Flexium+ 6 and Flexium+ 8 System

Flexium+ 6 and Flexium+ 8 are the right choice for controlling machines with relatively few axes and spindles, but with a high demand for speed and precision.

Flexium+ 6 is designed for milling and turning machines, as well as for water jet and laser cutting machines.

Flexium+ 8 offers additional features for cylindrical and flat grinding, and for gear cutting. It can also be adapted to the requirements of special machines.

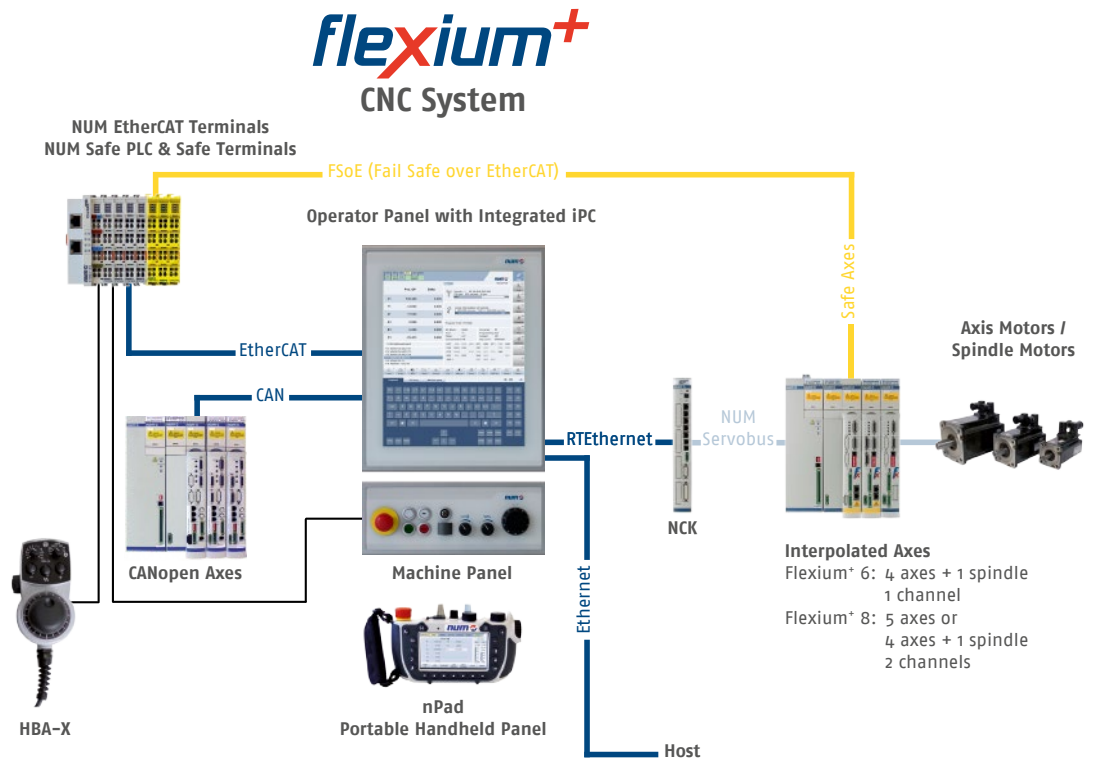



# Flexium+ Configurations

## Multi-Panel Configuration of Flexium+

### Flexium+ Multi-Panel

For operation of large machines, several HMIs are often connected modularly; a requirement Flexium+ easily meets.

With FS192i and MP05:

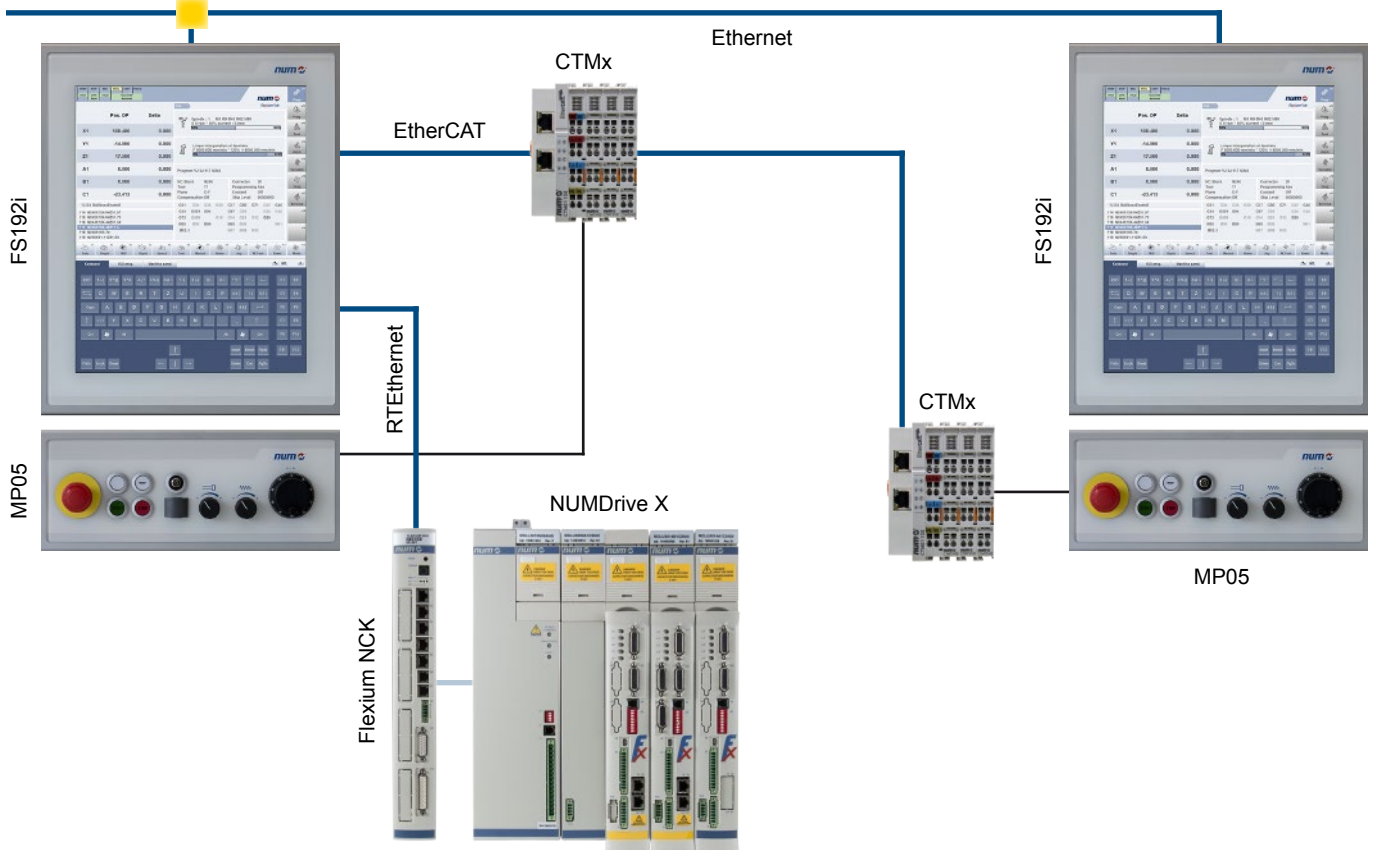

With FS153i and MP04:

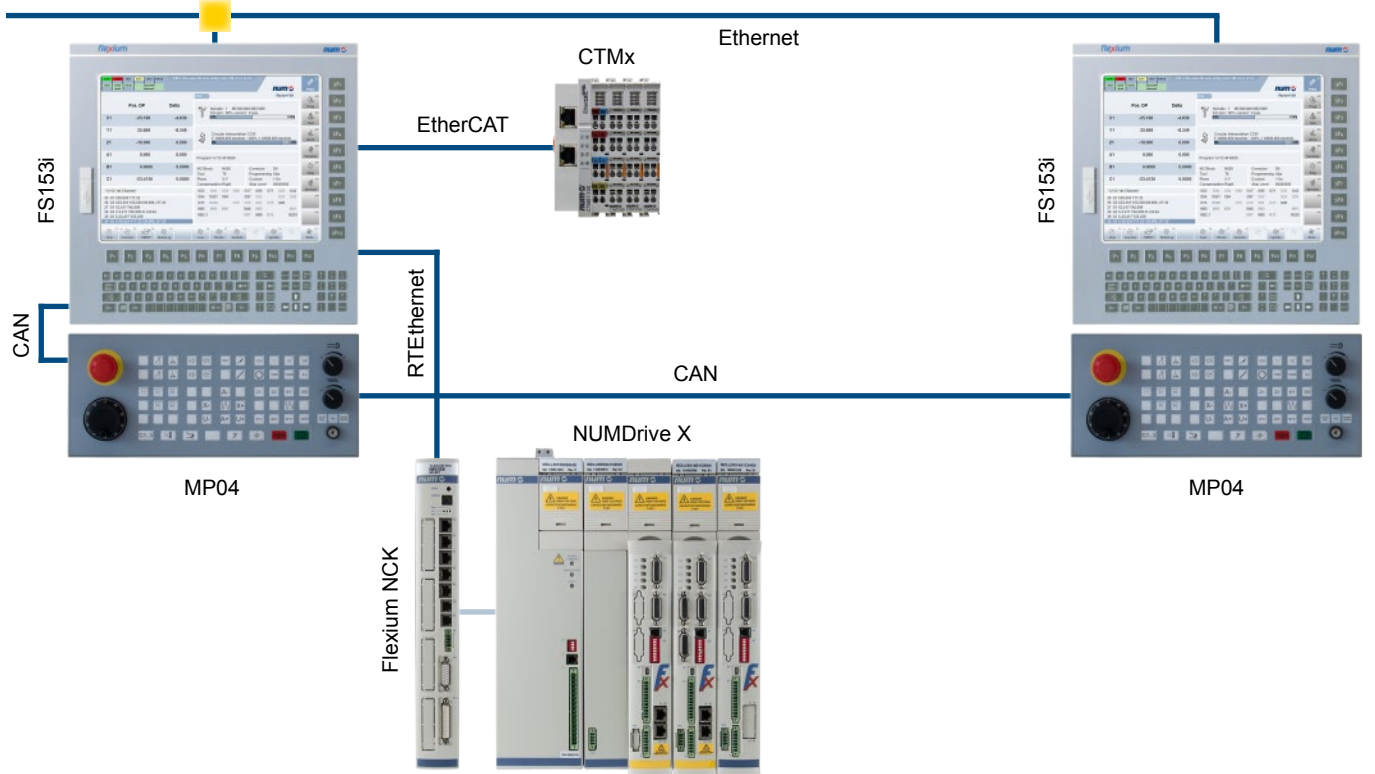

# Flexium+ Configurations

## Flexium+ Configuration for Office PC

### Flexium+ and Office PC

Custom applications such as CAD / CAM programs usually work best with a high performance PC and therefore it is not unusual for this computer to be replaced with a faster version a number of times during the lifespan of a machine.

This objective also applies to NUMROTOplus®.

We offer a configuration with an industrial PC (Industrial Box PC). This unit includes the real-time environment for the PLC.

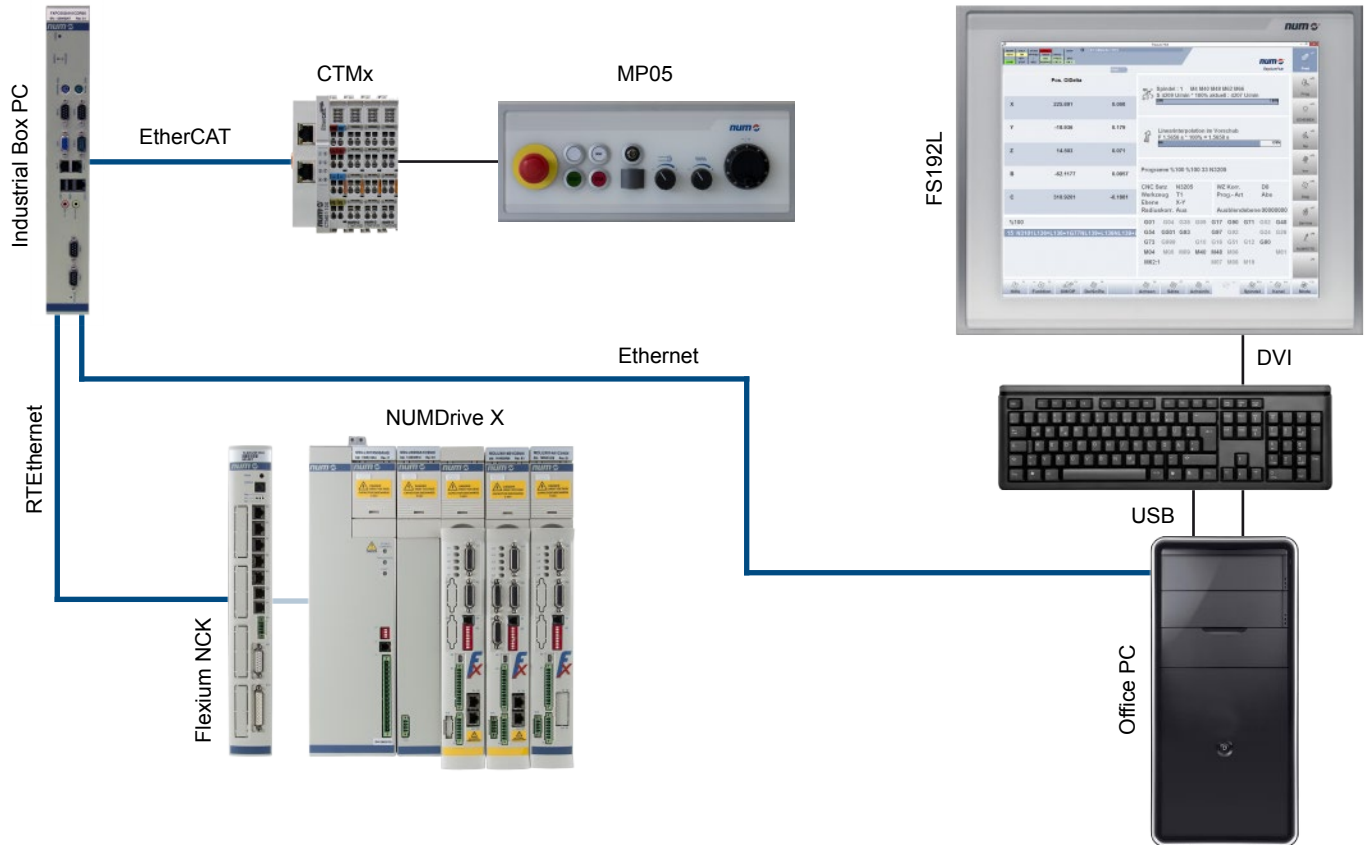

# Flexium+ Configurations

## Flexium+ Configuration with Foreign Panel

### Flexium+ and Foreign Panel

Flexium+ also provides a solution for the use of customized user devices. These can be connected to the system via the industrial PC (Industrial Box PC).

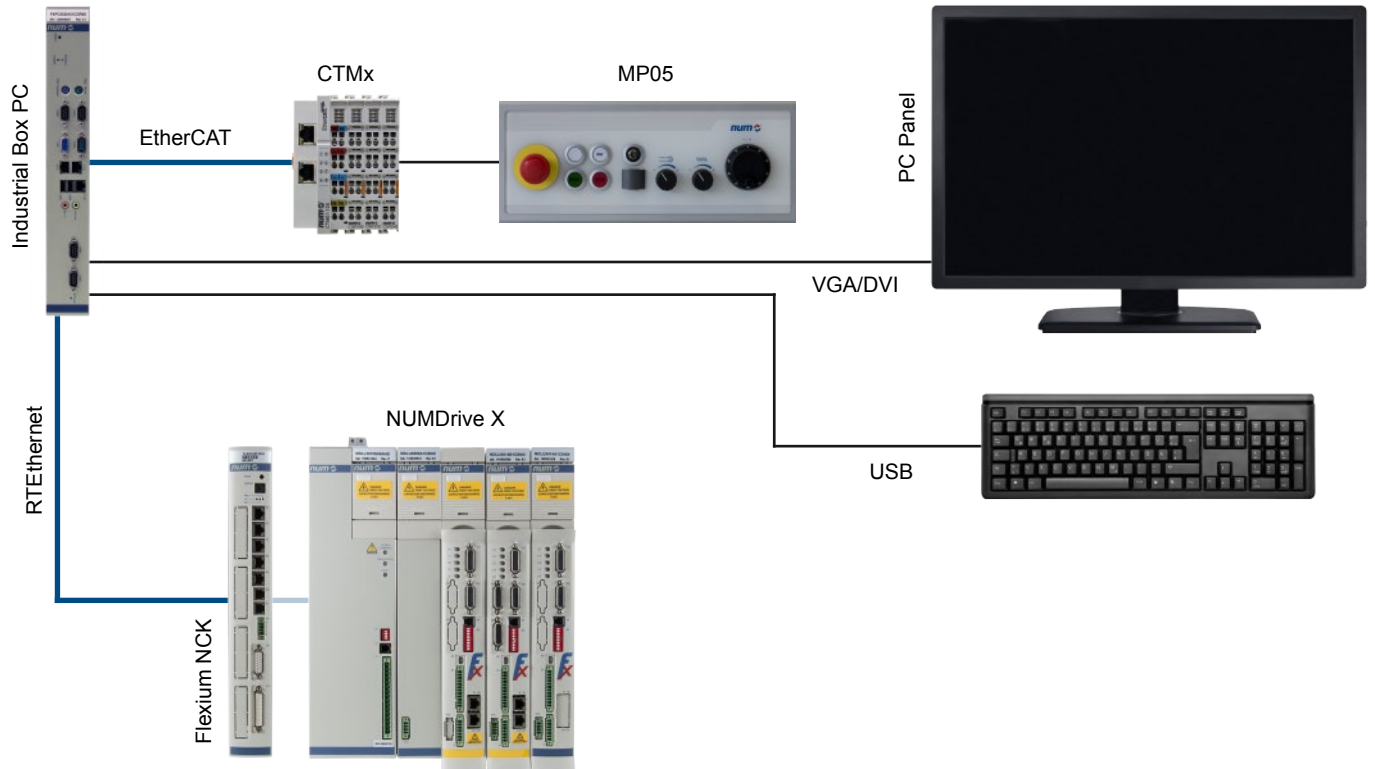

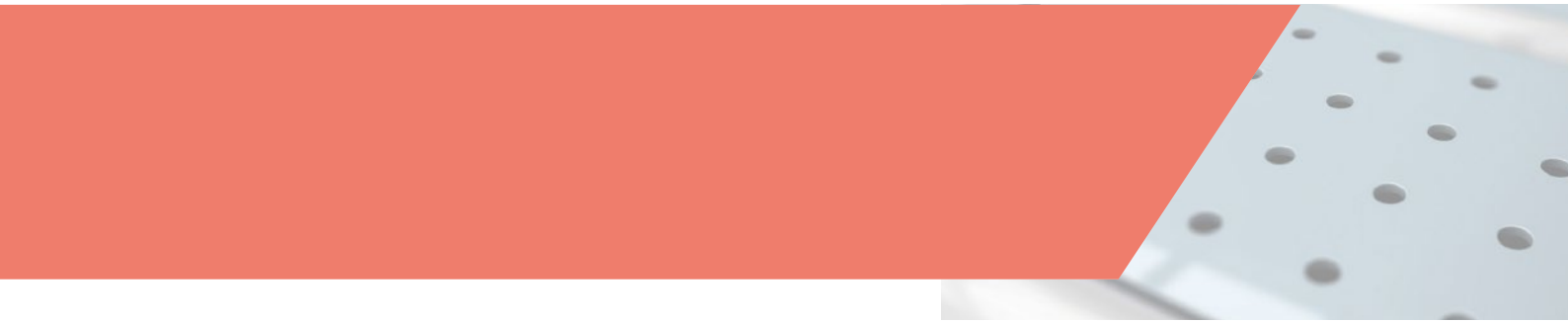

	Page
<b>Adresses / Contacts of all NUM Subsidiaries</b>	<b>265</b>
<b>Regulations</b>	<b>268</b>



### NUM Worldwide

#### Headquarters

#### NUM Worldwide

Country	Address	Telephone	Fax, Email
<b>Switzerland</b>	NUM AG Battenhusstrasse 16 9053 Teufen	+41 71 335 04 11	+41 71 333 35 87 sales.ch@num.com service.ch@num.com

#### Subsidiaries, Distribution and Service

##### Europe

Country	Address	Telephone	Fax, Email
<b>Austria</b>	NUM, Verkaufsbüro Österreich Hafenstrasse 47-51 4020 Linz	+43 732 33 63 81	+41 713 33 35 87 sales.at@num.com service.ch@num.com
<b>Denmark</b>	Caverion A/S Teglvaenget 75 7400 Herning	+45 9627 4000	+45 9627 6511 herning@caverion.dk
<b>Finland</b>	NUCOS OY Keiserinviitta 16 33960 Pirkkala Tampere	+358 3 342 7100	+358 3 342 7130 oiva.viitanen@nucos.fi
<b>France</b>	NUM S.A.S. Immeuble le Naxos 56, rue des Hautes Pâtures 92737 Nanterre Cedex	Hotline: +33 156 47 58 06 Sales: +33 156 47 58 58	+33 156 47 58 90 sales.fr@num.com service.fr@num.com
<b>Germany</b>	NUM GmbH Zeller Strasse 18 73271 Holzmaden	+49 7023 7440-0	+49 7023 7440-10 sales.de@num.com service.de@num.com
<b>Germany North</b>	NUM GmbH Niederlassung Nord Sudfeldstrasse 29-31 58093 Hagen	+49 2331 7398473	+49 2331 7396564 sales.de@num.com service.de@num.com
<b>Germany East</b>	NUM GmbH	+49 9471 6057356	sales.de@num.com service.de@num.com
<b>Italy</b>	NUM SpA Sede Legale Via F Somma 62 20012 Cuggiono (MI)	+39 02 97 969 350	39 02 97 969 351 sales.it@num.com service.it@num.com
<b>Spain</b>	NUM CNC HighEnd Applications S. A. ERREMENTARI PLAZA 8 Post Box 55 20560 Oñati	+34 943 78 02 65	sales.es@num.com service.es@num.com

Please see [www.num.com](http://www.num.com) for further contacts and most recent contact details.

# General Information

## Addresses / Contacts of all NUM Subsidiaries

### NUM Worldwide

#### Subsidiaries, Distribution and Service

##### Europe

Country	Address	Telephone	Fax, Email
<b>Sweden</b>	ConRoCo AB Formvägen 1 77793 Söderbärke	+46 240 65 01 16	+46 240 65 01 21 info@conroco.com
<b>Switzerland</b>	NUM SA Rue du Marché Neuf 30 2500 Bienne 3	+41 32 346 50 50	+41 32 346 50 59 sales.ch@num.com service.ch@num.com
<b>United Kingdom</b>	NUM (UK) Ltd. Unit 5 Fairfield Court Seven Stars Industrial Estate Wheler Road Coventry, CV3 4LJ	0871 750 40 20 International: +44 2476 301 259	0871 750 40 21 International: +44 2476 305 837 sales.uk@num.com service.uk@num.com
<b>Turkey</b>	NUM Servis Turkiye Feyzullah Caddesi Kirlı APT B Blok No: 17/4 34840 Maltepe-Istanbul	+90 542 265 80 54	+90 538 425 66 11 numserviceturkiye @yahoo.com.tr

##### Africa

Country	Address	Telephone	Fax, Email
<b>Algeria (Maghreb)</b>	R.M.O France 2 rue Paul Herbe 95200 Sarcelles	+33 1 39 90 71 10	rmoacn@yahoo.fr
	NUM S.A.S. Immeuble le Naxos 56, rue des Hautes Pâtures 92737 Nanterre Cedex	+33 1 56 47 58 00	+33 1 56 47 58 90 sales.fr@num.com service.fr@num.com
<b>South Africa</b>	MTP Retrofitting Services Fraser Street 12 Building K2, Vanderbijlpark 1900 P.O. Box 1187	+27 16 931 0642	+27 86 546 0547 abraham@mtpsa.co.za

##### Americas

Country	Address	Telephone	Fax, Email
<b>USA</b>	NUM Corporation 603 East Diehl Road, Suite 115 Naperville, IL 60563	+1 630 505 77 22	+1 630 505 77 54 sales.us@num.com service.us@num.com
<b>Brazil</b>	LOSUNG Technical Assistance and Comerce Ltda. Av. Anápolis, 500 06404-250 Bethaville-BARUERI-SP	+55 11 419 13 714	+55 11 419 58 210 losung@uol.com.br
<b>Mexico (Central America)</b>	VISI Series México, S.A. de C.V. Sierra de Ahuacatlan, No. 136 Villas del Sol Santiago de Querétaro, Qro. CP 76046	+1 442 248 2125	+1 442 223 6803 service.mx@num.com

Please see [www.num.com](http://www.num.com) for further contacts and most recent contact details.

### NUM Worldwide

#### Subsidiaries, Distribution and Service

##### Asia/Australia

Country	Address	Telephone	Fax, Email
<b>China</b>	NUM S.A. Beijing Office Room 904, No. 4 Building, Brilliancy International Plaza, Shangdi 10th Street, Haidian District, Beijing 100085	+86 (0)519 8585 0766	+86 (0)519 8585 0768 sales.cn@num.com service.cn@num.com
	NUM Numerical Control Technology (Changzhou) Co. Ltd The 5th floor, Haiye building No. 1-2 Guihua Road, Zhonglou District 213023 Changzhou	+86 (0)519 8585 0766	+86 (0)519 8585 0768 sales.cn@num.com service.cn@num.com
	JTSC Co. LTD Wuhan Room 302, Fengcai Building B, Huifeng Qiyezongbu, No. 2 Gutian Road, Qiaokou District, Wuhan City, Hubei Province	+86 27 8331 3040	+86 27 8331 3040 junzhuyu@tom.com
	Mingliwang Guangdong No. L23, Changrong Mechanic & Metals Plaza, Changan Town, Dongguan City, Guangdong Province	+86 10 5885 1991/98	+86 10 5885 1990 HYW2003gz@163.com
<b>Malaysia</b>	IME Trading Sdn. Bhd. 30A, Jalan PJS 1/46, Petaling Utama 46150 Petaling Jaya, Selangor	+60 3 7783 6866	+60 3 7783 4384 tk@cadcam.com.my
<b>Taiwan</b>	NUM Taiwan Ltd. 7F-2 No. 536, Sec. 2 Taiwan Boulevard Taichung City 40353	+886 4 2316 9600	+886 4 2316 9700 sales.tw@num.com service.tw@num.com
<b>Thailand</b>	Gsixty Co. Ltd. 508/51 Sukhontasawat Road Ladphrao, Bangkok 10230	+66 2 578 34 54	+66 2 578 34 54 jameschaput@hotmail.com
<b>South Korea</b>	NUM CNC KOREA Co. Ltd. A-503, Hangang Xi-Tower, Yangcheon-ro 401, Gangseo-gu 157801 Seoul	+82 2 6968 5767	+82 2 6968 5760 sales.kr@num.com service.kr@num.com
<b>Australia</b>	Australian Industrial Mach. Serv. Pty. Ltd. 28 Westside Drive Laverton North Victoria 3026	+61 3 9314 3321	+61 3 9314 3329 enquiries @aimservices.com.au

##### India

Country	Address	Telephone	Fax, Email
<b>India</b>	Peschel Dynamics Vishwakrupa s. no. 1 , Hissa No. 4 Narhe Gaon, Pune 411041	+20 3241 6980	+20 2431 7310 info@pescheldynamics.com

Please see [www.num.com](http://www.num.com) for further contacts and most recent contact details.

### Compliance with EU Directives Relative to Electromagnetic Compatibility (EMC) (89/336, 92/31 and 93/68) and Low Voltage (73/23 and 95/68)

---

The list of standards with which NUM CNCs and servo drives comply is given in the conformity statements which can be supplied on request.

The products described herein must be used in compliance with the recommendations given in our Installation and Wiring Guide (on CD-ROM with basic documentation or 938 960).

The products of this catalog are designed for integration in a machine complying with Machine Directive 89/392/EEC.

---

### Export Terms for CNC products

---

1. – Because of their technical characteristics or in some case their utilization, certain of NUM's products may be required to comply with the requirements of Swiss or European regulations and/or US regulations concerning control of the final destination.

Relevant information is given on our purchase order acknowledgments, invoices and delivery notes.

These provisions apply to NUM's products so identified on our purchase order acknowledgments, invoices and delivery notes.

2. – Accordingly, the purchaser undertakes to fully comply in all respects with the regulations of his country and, as the case may be, with Swiss, European and / or US regulations relating to the control of final destination of dual use products.

The purchaser undertakes to introduce and to follow its own business control procedures in order to ensure that, in respect of the resale of Dual Use Products, such national legal obligations will be implemented.

3. – In any case, the purchase orders received by NUM shall be accepted subject to NUM obtaining any required authorizations.

© Copyright NUM AG, Teufen/CH, 2015 (DSc/MMA)

All rights reserved. No part of this document may be copied or reproduced in any form or by any means whatsoever, including photographic or magnetic processes. The transcription on an electronic machine of all or part of the contents is forbidden.

The software mentioned herein is the property of NUM AG. Each copy of the software confers on the holder a nonexclusive license strictly limited to use of the said copy. No copy or other form of duplication of this product is authorized, with the exception of backup copies of the software.

The physical, technical and functional characteristics of the hardware and software products and the services described in this document are subject to modification and cannot under any circumstances be construed as contractually binding.

NUM, Motorspindle and NUMtransfer are registered trademarks of NUM AG.

Windows is a registered trademark of Microsoft Corporation.

