

# flexium

## CNC SYSTEM 2015/2016

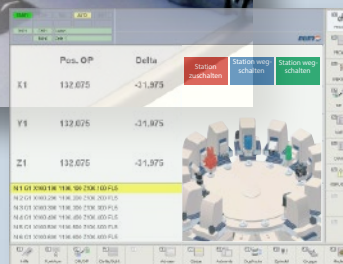
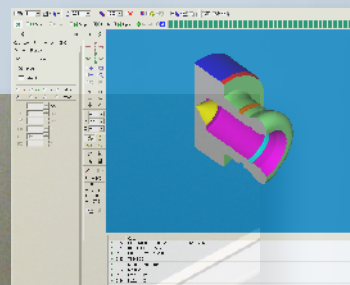

[www.num.com](http://www.num.com)

**NUM**   
CNC HighEnd Applications

# Catalog

---

## Flexium CNC System

Edition 2015/2016

### Chapter overview

---

**1 Introduction**

1

**2 Flexium CNC System**

2

**3 Flexium CNC System Completion**

3

**4 Flexium CNC System Software**

4

**5 NUM Motors**

5

**6 NUM Servo Drives**

6

**7 Motor/Drive Associations**

7

**8 General Information**

8

---

---

# Catalog

## Flexium CNC System

Edition 2015/2016

### Executive Summary

	Page
<b>1 Introduction</b>	<b>7</b>
NUM, A World Player in Machine Automation	7
Flexium System Overview	8
Flexium System Configuration	9
<b>2 Flexium CNC System</b>	<b>11</b>
CNC Hardware and Software	11
Introduction	13
Performance Levels	13
Functional Diagram	14
Technical Information	15
CNC Hardware Overview	15
Specifications, Outline Drawings	16
NUM Industrial Box PC, Specifications	17
Configuration	18
Summary Table	18
Configuration Options	19
Accessories Cables and Conectors	20
Software Options	21
Functions related to Axes and Spindles, Tool Management	21
Canned Cycles, Programming, Operating Mode Functions	22
Software Packs	23
Overview	23
Functions included in Packs	24
Flexium HMI	25
Options, NUMtransfer	25
Operation Panel PCs	26
FS152 Series	26
Machine Panels MP04, nPad, Handwheels	28
<b>3 Flexium CNC System Completion</b>	<b>33</b>
Peripheral Devices	33
Panels	35
General	35
Operator Panels FS152 Series	36
Operator Panels FS152 Series Dimensions and Cutout	38
NUM Industrial Box PC	39
Machine Panels MP04	40
Easy Backup	40
Machine Panels MP04	41
Portable Handwheel HBA-X	41
Panels	42
nPad - Mobile Operator Panel	42
NUM EtherCAT	46
Introduction, System Structure, NUM EtherCAT Terminal Performance	46
Technical Data Gateways	47
Technical Data Terminals	48
<b>4 Flexium CNC System Software</b>	<b>49</b>
Functional Specifications: Functional Block Diagram	51
System Architecture	51
Functional Block Diagram	51
System Integration and Customization	52
Flexium Suite	52
Flexium Tools	53
Flexium Tools	54
Flexium Tools: PLC Programming	55
CNC/PLC Exchange Area	56
Flexium SDK	57
Human Machine Interface	58
Flexium HMI	58
Options	59

# Catalog

## Flexium CNC System

Edition 2015/2016

### Executive Summary

	Page
System Requirements	60
Servosystem	61
Flexium CNC System	61
High-Level Functions	61
NUMcoss - an additional component of High Speed Cutting (HSC)	62
Axes	63
CNC, Linear, Rotary Axes, Positioning, and Interpolated Axes	63
Interpolation: Linear, Circular, Smooth Polynomial, Spline, NURBS	64
Inclined, Tilt, Duplicated, and Synchronized Axes	65
Multichannel Functions, Calibration, Compensations	65
Programmable Precision, Inch/Meter Units	66
Spindle	67
Automatic Spindle Speed Range Search, Indexing, Synchronization	67
Rigid Tapping, Constant Surface Speed, Thread Cutting	67
C Axis and Coordinate System Conversions, Axis/Spindle Synchronisation	68
Tool Management	69
Tool Axis Selection, Tool Wear Offsets, Turning Tool Offsets	69
Milling Tool Offsets, 3D Tool Offsets, Dynamic Tool Offsets by the PLC	70
Machining Cycles	71
Milling and Pocket Cycles, 3D Workpiece Position Compensation	71
Probing Cycles, Inclined Plane Machining	71
Machining Cycles	72
Milling and Pocket Cycles, 3D Workpiece Position Compensation	72
Probing Cycles, Inclined Plane Machining	72
RTCP, Auto n/m Function, HS Precision Contours, Radial Axis Boring/Milling	73
Functions: Combined Machine, Polygon Cutting	74
Cycles: Turning, Customized, Probing for Lathe	74
Program Interrupts	75
On-the-Fly Measurement Acquisition, Backtrack, Emergency Retraction	75
Part Programming	76
Part Program, Resident Macros, Manual Input, Drip Feed Mode	76
Datum Shifts, Dynamic Software Switches, ISO/EIA Language	77
Subroutines, Parametric/Structured Programming, Contour Table	78
Transfer of Active Settings, Scaling Factor, Programmed Angular Offset	78
Index Table Eccentricity Function, Profile Geometry Programming	79
<b>5 NUM Motors</b>	<b>81</b>
NUM Motors BHX, BPX, BPH, BPG, BHL, AMS, IM Spindle Motors, AMR	81
NUM Motors	83
Introduction	83
Applications	83
NUM Motors BHX, BPX, BPH, BPG, BHL	84
General Characteristics	84
Technical Characteristics	85
Technical Characteristics	86
Outline Drawings BHX Motors	89
Outline Drawings BHX Motors	90
Outline Drawings BPH and BPG Motors	91
Outline Drawings BHL Motors	92
Ordering Codes	93
Accessories	96
Accessory Descriptions	99
NUM Motors AMS and IM	100
General Characteristics	100
Technical Characteristics	101
Outline Drawings AMS Motors	102
Outline Drawings IM Motor	104
Ordering Codes	105
Accessories, Accessory Descriptions	106
Auto-Transformer	107
Technical Characteristics, Outline Drawings	107
Special and Built-In Motors	108
General Information	108

# Catalog

## Flexium CNC System

Edition 2015/2016

### Executive Summary

	Page
<b>6 NUM Servo Drives</b>	<b>109</b>
NUM Servo Drives	109
General Information	111
Introduction	111
Common Characteristics	111
Power Supplies	112
Introduction	112
Technical Characteristics	112
Outline Drawings	113
Ordering Codes	114
Accessories	114
NUMDrive C	115
Introduction	115
Interoperability and Functions	116
Interoperability and Functions	117
Technical Characteristics	118
Outline Drawings	119
Ordering Codes	120
Ordering Codes	121
Accessories	122
Accessories	123
Capacitor Module: Technical Characteristics, Outline Drawing	123
Filters: Technical Characteristics	124
Filters: Outline Drawings	125
Line Chokes: Technical Characteristics	126
Line Chokes: Outline Drawings	127
Braking Resistors: Technical Characteristics, Outline Drawings	128
Brake resistance: Outline Drawings	129
Mechanical Adapter: Outline Drawings	130
Mechanical Adapter: Outline Drawings	131
<b>7 Motor/Drive Associations</b>	<b>133</b>
Servo and Spindle Motors	133
Servo Motors	135
Association of BHX Motors with NUMDrive C (Switching Frequency 10 & 5 kHz)	135
Association of BPX Motors with NUMDrive C (Switching Frequency 10 & 5 kHz)	136
Association of BPH Motors with NUMDrive C (Switching Frequency 10 kHz)	137
Association of BPH Motors with NUMDrive C (Switching Frequency 5 kHz)	138
Association of BPG Motors with NUMDrive C (Switching Frequency 10 & 5 kHz)	139
Association of BHL Motors with NUMDrive C (Switching Frequency 10 & 5 kHz)	140
Spindle Motors	141
General Description	141
Services	141
Association of AMS and IM Spindle Motors with NUMDrive C (Switching Frequency 5 kHz)	142
<b>8 General Information</b>	<b>143</b>
NUM Worldwide, Regulations	143
NUM Worldwide	145
Regulations	148

---

---

# 1 Introduction

## NUM, A World Player in Machine Automation

### **CNC Power Engineering**

#### ***Always on the move***

***NUM supplies CNC complete solutions for the automation of production machines in special market segments and for customers with special requirements.***

***The high flexibility of our systems and innovative engineering-team with extensive application know-how allow us to tailor the systems exactly to the needs of our partners – the machine manufacturers and the machine industry.***

#### **Mission Statement:**

**NUM CNC solutions provide Machine Builders with a competitive advantage.**

Founded in 1978 and with roots back into the late fifties NUM is today an independent European company with growing international activities.

#### **Accompaniment and support during the entire product life cycle**

When you select a system and a solution from NUM, you are making a long-term investment. As your partner, we take part through the entire process: from the conception of the idea to its execution, from on-site customer service to retrofitting years later, giving new life to quality used machines.

NUM supports you and your projects to achieve the best results for your company and your infrastructure. The goal of our cooperation, however, always remains the same: collaborating to create the best-possible solution for your project.

All of our solutions are based on a wide range of our own perfectly integrated products, such as CNC, servo drives and motors. Partnership with our customers is maintained in the evaluation, project and installation phases by means of training courses, support and service centres, and continue after commissioning. We make a point of advising our customers with specific know-how from our experts.

When you choose NUM, you are also choosing customer service which will continue to serve you just like new long after you have made your initial investment – even after 20 years, we still serve on-site. Our specialists can extend the life of your quality older machines with NUM Retrofits.

NUM is committed to transferring its knowledge on a regular basis. CNC knowledge, special production expertise as well as drive and application techniques are the subjects of the training programs taught by our specialists.

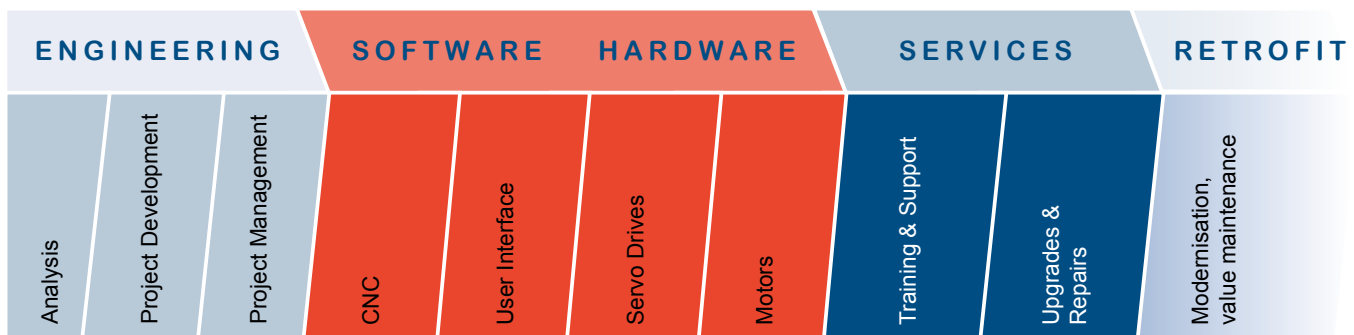



# Introduction

## Flexium System Overview



### A Compact Scalable CNC System

Flexium CNC is a key element of the solutions and systems of NUM.

The Flexium system is easily scalable and can be fully adapted to the needs of the customers. Available in three configurations Flexium 6, Flexium 8 and Flexium 68, each equipped with specific functions and function packages, it can be tailored to the particular application.

To create an optimal CNC, just pick the platform best suited to the application and the machine as well as options individual or grouped in technology packages (turning, milling, woodworking, etc.).

#### Flexium 6

- Up to 5 axes + spindles with a maximum of 4 axes (among the 5, two can be analog).
- Single channel structure.
- Choice of kinematic structure: milling or turning.
- Up to 4 axes simultaneously interpolated (more complex interpolations such as Spline or NURBS - Non Uniform Rational B-Spline - require Flexium 8 or Flexium 68).
- Option packs available: Milling M0 or Turning T.

#### Flexium 8

- Up to 5 axes + spindles with a maximum of 5 axes (among the 5, two can be analog).
- Second channel as an option.
- Various options related to axes, such as Spline or 3D Smoothing or spindles like thread cutting or rigid tapping as well as technology packages are available.

#### Flexium 68

- CNC for 5 axes + spindles in standard version, up to 32 axes + spindles as an option.
- Up to 4 spindles.
- One channel as standard, 2, 4, 6 or 8 channels optional.
- Interpolates 4 axes per channel as standard, optionally up to 9 interpolated axes per channel (more complex interpolations such as Spline or NURBS available as options).
- Various technology packages are available as options.

### Open, User-Friendly and Ergonomic, Guaranteed Efficiency

NUM systems are known for their high degree of flexibility and adaptability to various configurations. This is achieved, among other features, by powerful functions and PC panels with dedicated Human Machine Interface (Flexium HMI).

#### CNC Functions

Flexium systems have high-level CNC functions such as dynamic operators in C and high performance servo drive algorithms such as the Tandem function, allowing a perfect adaptation to all machines to improve their productivity.

#### Control panels with an integrated industrial PC

Depending on the application, two power levels can be selected. Reliable and well suited to their usage, they form an ideal partnership with the Flexium NCK.

#### Human Machine Interface

Each OEM can use or adapt the Flexium HMI or develop his own interface using widespread off-the-shelf tools: HTML editor, Visual Basic, C #, etc.

### NUM Motors: Perfect for all Applications

The comprehensive NUM motor series offer an excellent volume/performance ratio and great dynamics, and are suited to almost all applications. In combination with the NUM drives, these motors offer an excellent stability even with very low rotational speeds and can be easily integrated into machines.

#### Brushless axis motors

The NUM axis motors offer an excellent volume/performance ratio and their perfectly smooth operation even at the lowest is convincing. The new motors of the BHX and BPX series complete the range, in addition to an advantageous price/performance ratio, they are characterized by a mass moment of inertia well adapted to the machine industry. The spectrum of all motor types extends from 0.5 Nm to 160 Nm continuous torque.

#### Spindle motors

The asynchronous motors of the AMS series offer excellent regularity at low rotational speeds, quick and accurate positioning, and are extremely well suited as a C axis and to spindle indexing. The spectrum ranges from 2.2 kW to 55 kW.

#### Motorspindle®

The active parts of the motor are integrated directly in the spindle, which ensures increased rigidity of the machine and greater quietness of running. On request NUM is pleased to develop special motor spindles.

As well as the standard product NUM builds customised motors in order to fulfil the customer requirements.

### NUMDrive C: Compact Precision and Dynamics

The NUMDrive C servo drives with their modern design are the ideal counterpart to the powerful Flexium CNC. Modular in design, compact in their dimensions and with low power consumption, they correspond ideally to the needs of modern systems.

One distinguishing feature of the NUMDrive C is its high power density. The servo drives offer an enormous amount of computing and drive power within a very small space and thus have one of the highest power/space ratios available. The wide range of power modules and scalable control units, available in Mono-Axis or Bi-Axis versions, enables the technically best and most economical solution to be implemented. For the maximum contour precision, speeds and cost-effectiveness, the NUMDrive C servo drives can be exactly adapted to the particular machine and application.

# Introduction

## Flexium System Configuration

### Format of the Commercial References

The commercial references of the Flexium CNC Systems are composed of alphanumeric characters:

<b>ABCD</b>	<b>123 456</b>
Nature of the item	Commercial reference number

The first group of 4 characters immediately identifies the nature of the item:

- **FXP1**: Flexium 6 or Flexium 8 Platform
- **FXP2**: Flexium 68 Platform
- **FXSO**: Flexium Software Option  
Software functions such as canned cycles or interpolations
- **FXHO**: Flexium Hardware Option  
Future developments
- **FXSW**: Flexium Software  
Integration and operation software
- **FXPC**: Flexium PC Panels
- **FXHE**: Flexium External Hardware Option  
CNC machine panels, connectors, etc.
- **FXHC**: Flexium Miscellaneous Cables
- **FXDO**: Flexium Documentation  
Technical documentation on CD-ROM
- **CTMx**: NUM EtherCAT gateways and terminals
- **nPad**: NUM Portable Handheld Panel

All the options can be ordered individually, provided they are available for the selected platform.

Moreover, the job-specific FXPA packs provide several functions under a single reference. These job-specific packs consist of sets of functions clearly meeting application needs: Turning, Milling, Grinding, Gear Hobbing, Water-Jet cutting, Woodworking Applications, Stone-cutting Applications, etc.

For NUM motors and servo drives, the references are constructed based on the required features and options.

### Functions Available for Each Platform

The tables in Chapter 2 list the functions supplied with each platform as well as the available options:

- Function included in the basic platform,
- Optional function compatible with the platform selected,
- Function not available for the platform considered.

### Selecting a Flexium System

To select the system best suited to your machine, we recommended proceeding in the following order:

1. Determine the platform based on the number of axes and functionality required  
→ (Flexium 6, Flexium 8 or Flexium 68)
2. Select the Human Machine Interface  
Operator panel (FS152i series), machine panel (MP04) or portable operator panel  
→ (FXHE, FXPC, FXHC)
3. Select the job-specific pack or individual software options you need for your application  
→ (FXPA, FXSO)
4. Software tools resident in the CNC or PLC designed to facilitate CNC integration and customization to the application  
→ (FXSW)
5. Technical documents required  
→ (FXDO)
6. Determine the drive systems best suited to your application (see Chapter 7).

---

---

# 2 Flexium CNC System

CNC Hardware and Software

Table of Contents

---

	Page
<b>Introduction</b>	<b>13</b>
Performance Levels	13
Functional Diagram	14
<b>Technical Information</b>	<b>15</b>
CNC Hardware Overview	15
Specifications, Outline Drawings	16
NUM Industrial Box PC, Specifications	17
<b>Configuration</b>	<b>18</b>
Summary Table	18
Configuration Options	19
Accessories Cables and Conectors	20
<b>Software Options</b>	<b>21</b>
Functions related to Axes and Spindles, Tool Management	21
Canned Cycles, Programming, Operating Mode Functions	22
<b>Software Packs</b>	<b>23</b>
Overview	23
Functions included in Packs	24
<b>Flexium HMI</b>	<b>25</b>
Options, NUMtransfer	25
<b>Operation Panel PCs</b>	<b>26</b>
FS152 Series	26
Machine Panels MP04, nPad, Handwheels	28



# Flexium CNC System

---

## CNC Hardware and Software

### Introduction

### Performance Levels

---

#### Introduction

Flexium is a complete, user-friendly and versatile CNC system, which is probably the most adaptable currently on the market. It consists of:

- CNC Kernel – Flexium NCK
- Operator panels with integrated PC
- Human Machine Interface: Flexium HMI
- PLC software
- Machine panel
- Remote inputs/outputs – NUM CTMxxx
- Servo drives – NUMDrive C
- NUM Motors - various ranges

All these elements of the Flexium CNC System are described in this catalogue. Use the full table of contents in chapter 1 for navigation.

---

#### Performance Levels

The Flexium CNC System is easily scalable and can be flexibly adapted to the needs of the customers. Available in three configurations, and equipped with specific functions and function packages, it can be tailored to almost any particular application.

##### **Flexium 6**

- CNC with choice of kinematic structure: milling or turning
- For CNC for up to 4 axes and 1 spindle
- One CNC channel
- Interpolates up to 4 axes simultaneously  
(more complex interpolations such as Spline or NURBS require Flexium 8 or Flexium 68)
- Options packages available: Milling: M0 or Turning: T

##### **Flexium 8**

- For CNC for up to 5 axes or 4 axes and 1 spindle.
- One channel is standard, a second is optionnaly available
- Interpolates up to 4 axes simultaneously  
Various options and technology packages available

##### **Flexium 68**

- CNC for 5 axes + spindles in standard version, up to 32 axes/spindles as an option  
(with a max of two analog)
- Up to 4 spindles may be parameterized,
- One channel is standard, 2, 4, 6 or 8 channels as an option
- Interpolates 4 axes par channel as standard, up to 9 interpolated axes per channel as an option  
(more complex interpolations such as Spline or NURBS available as options)
- All technology packages are available as options

See next page for simple functional diagrams.

# Flexium CNC System

CNC Hardware and Software

Introduction

Functional Diagram

## Compact systems: Flexium 6, Flexium 8

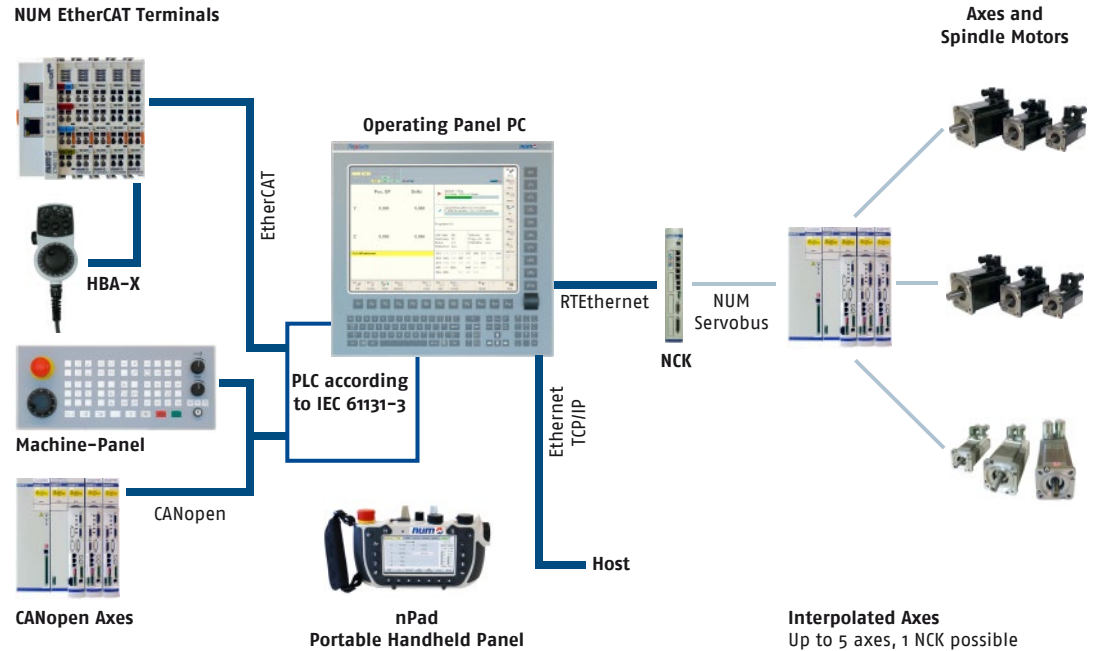

## Fully scalable system: Flexium 68

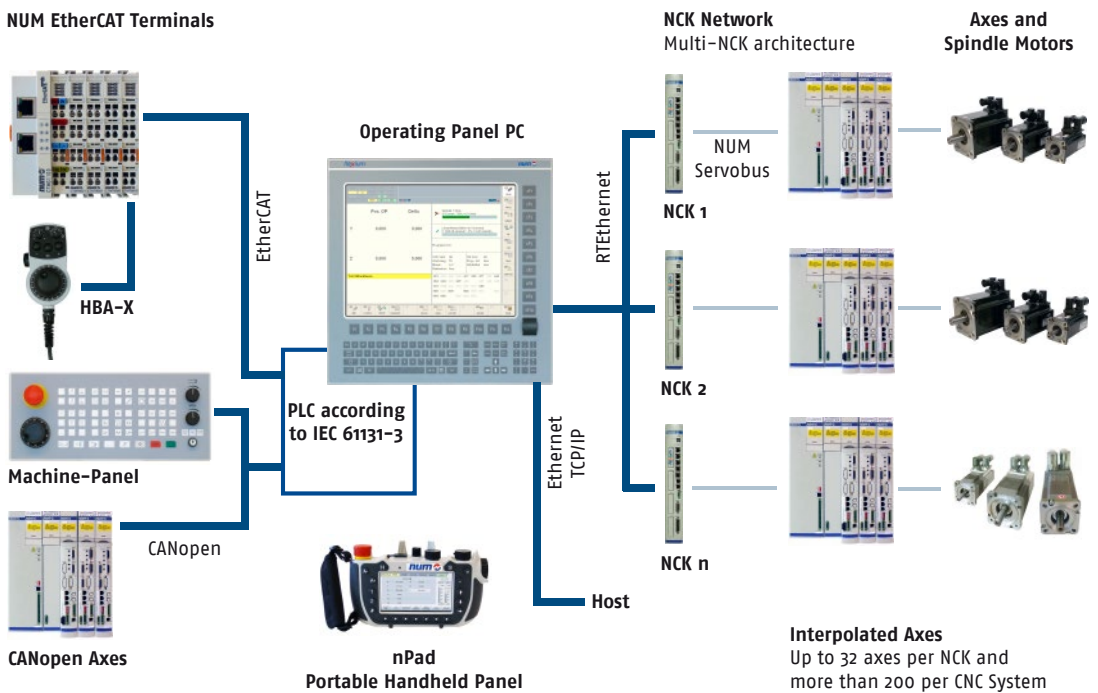

# Flexium CNC System

## CNC Hardware and Software

### Technical Information

#### CNC Hardware Overview

#### CNC Hardware Overview

The hardware is identical between Flexium 6, Flexium 8 and Flexium 68. Some features such as analog axes and handwheels require a software option.

The Flexium NCK provides 32 High Speed digital inputs and outputs (16 each, see 12) for the most accurate and perfect control of the system (Connectors are in option).

#### Front view

- 1 Reset button
- 2 NCK address
- 3 Status lights
- 4 3 DISC NT rings
- 5 Ethernet port for multi-NCK configuration
- 6 Ethernet port for operator panel
- 7 NCK clock output
- 8 NCK clock input
- 9 Watch-dog interface
- 10 Analog I/Os
  - 2 outputs 16bits +/-10VDC
  - 4 inputs 12bits -10/0 ...10VDC
- 11 Probing
  - 2 inputs 24VDC
- 12 Direct digital I/Os
  - 16 inputs 24VDC
  - 16 outputs 24VDC / 1A
- 13 4 slots for expansion boards

#### Top view

- 14 2 types of power supply
  - 24VDC 1A
  - 50VAC 35kHz (from MDLL)

#### Bottom view

- 15 and 16, each:
  - 1 Analog axis or Handwheel
    - Reference:  $\pm 10$ VDC 16bits
    - Measure: quadrature complemented incremental encoder with zero pulse
- 17 Serial port for debug (internal use only)

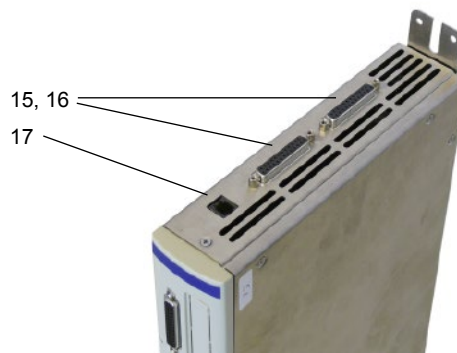
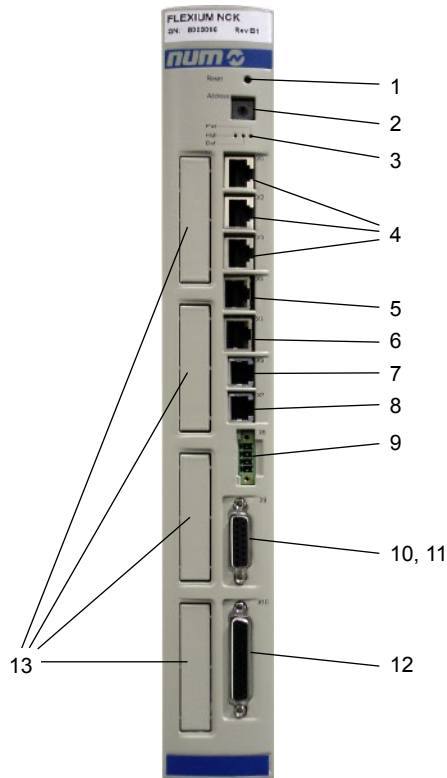



# Flexium CNC System

CNC Hardware and Software

Technical Information

Specifications, Outline Drawings

## Specifications

Power supply voltage	24 VDC +20% -15%
Power consumption	50 W
Protection class	IP20
Relative humidity, noncondensing	max. 75%
Operating temperature range	0°C to 40°C
Storage temperature range	-25°C to +70°C
Overall dimensions (L x H x D)	50 x 355 x 206 mm
Weight	2.2 kg

## Outline Drawings

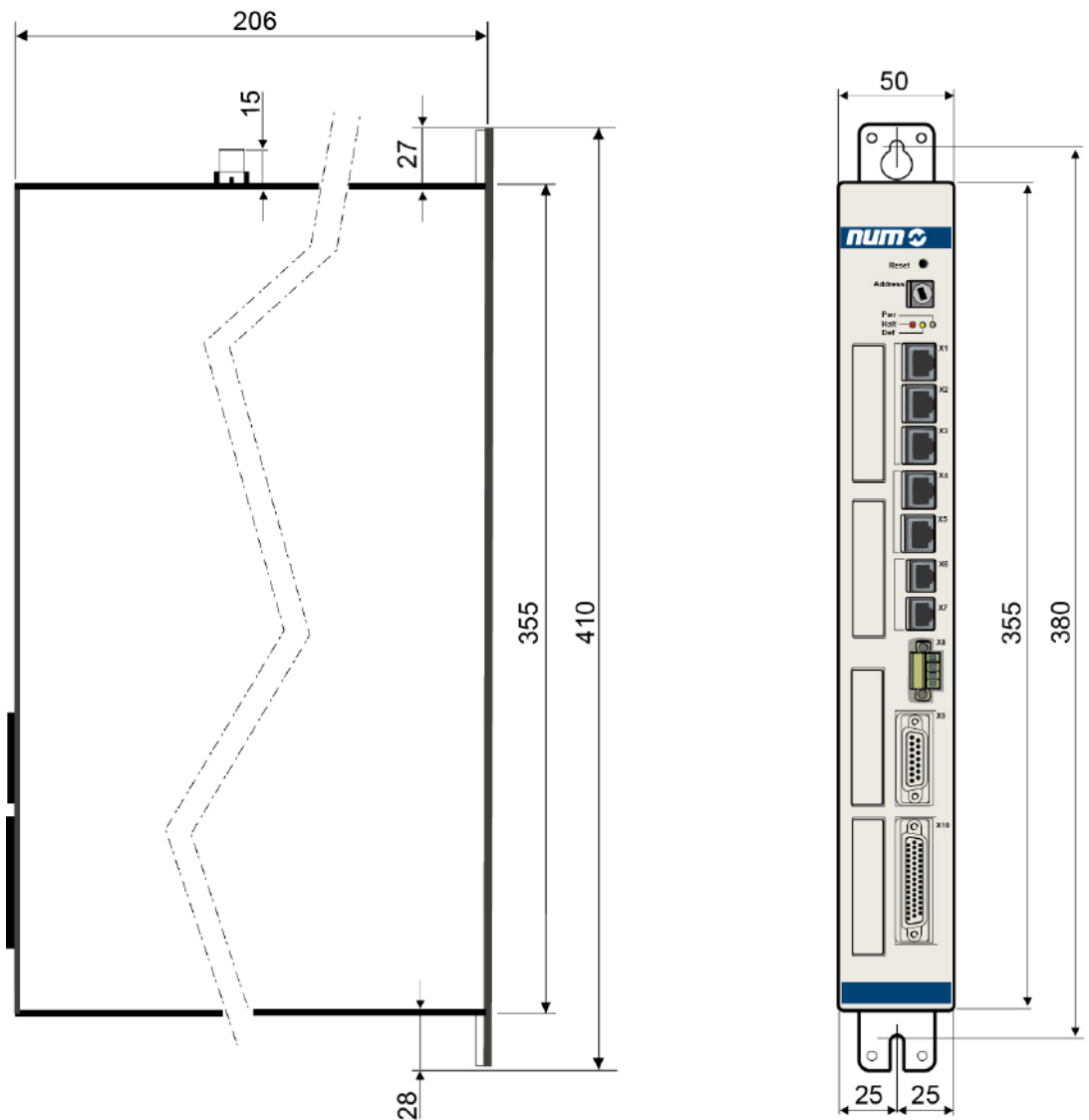

# Flexium CNC System

CNC Hardware and Software

Technical Information

NUM Industrial Box PC, Specifications

## Box PC Scheme as PLC (DPLC substitution)

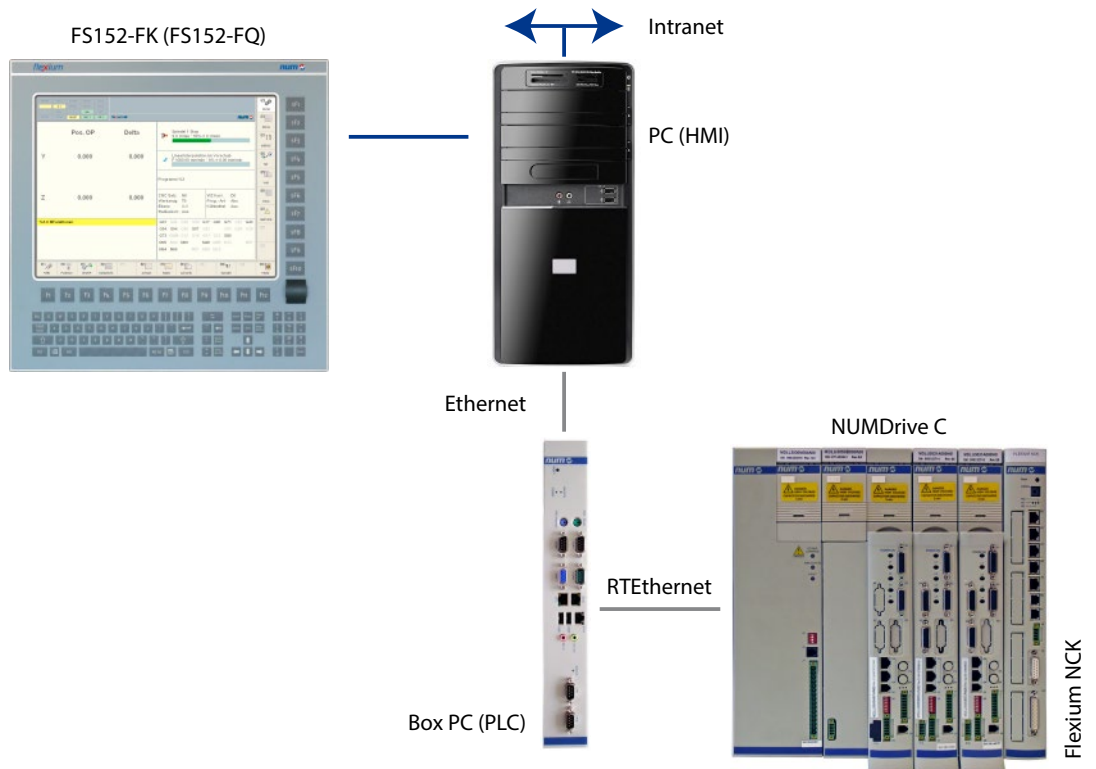

## Box PC Scheme as Panel PC and PLC

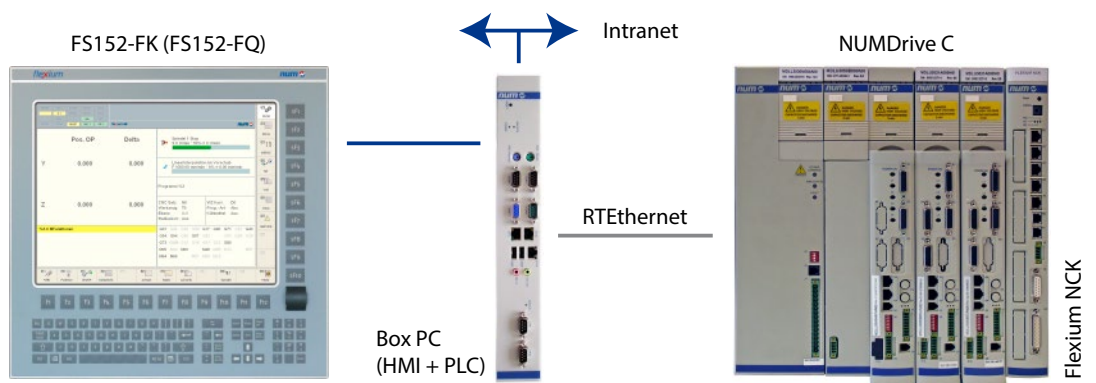

# Flexium CNC System

## CNC Hardware and Software

### Configuration Summary Table

#### Summary Table

Further equipment such as handwheels and machine panels can be integrated using CANopen.

Min/Max Configurations	Flexium 6	Flexium 8	Flexium 68
<b>Total : Axes + spindles + measurements (digital and analog)</b>			
Standard	5 *	5 *	5
Maximum	-	-	32
<b>Total : Axes + spindles + measurements (analog)</b>			
Standard	0	0	0
Maximum	2	2	2
<b>Axes (digital and analog)</b>			
Standard	4	4	5
Maximum	4	5 *	32
<b>Measured spindles (digital and analog)</b>			
Standard	0	0	0
Maximum	1	1	4
<b>Handwheels</b>			
Standard	0	0	0
Maximum (TTL max =2)	2	2	4
<b>Interpolated axes per channel</b>			
Standard	4	4	4
Maximum	4	4	9
<b>Channels</b>			
Standard	1	1	1
Maximum	1	2	8
<b>Inputs/Outputs (analog) on Flexium NCK</b>			
Standard Inputs / Outputs	4 / 2	4 / 2	4 / 2
<b>Inputs/Outputs (digital) on Flexium NCK</b>			
Standard Inputs / Outputs	16 / 16	16 / 16	16 / 16
<b>Probing inputs</b>			
Standard	2	2	2
<b>Inputs / Outputs (digital), remote</b>			
Standard	0	0	0
Maximum	4000+	4000+	4000+
<b>Program memory</b>			
CNC memory (NCK)	40 MB+	40 MB+	40 MB+
PLC memory	1'024 MB+	1'024 MB+	1'024 MB+

\* For Flexium 6: up to 5 axes + spindles with max. of 4 axes

\* For Flexium 8: up to 5 axes + spindles with max. of 5 axes

# Flexium CNC System

## CNC Hardware and Software

### Configuration

### Configuration Options

#### Configuration Options

Description	Commercial reference	Flexium 6	Flexium 8	Flexium 68	Comments
<b>Platforms</b>					
Flexium 6	FXP1 100 100	●	-	-	
Flexium 8	FXP1 100 150	-	●	-	
Kinematic configuration type T (Turning)	FXSO 200 060	○	○	○	Defined in the ordering process
Kinematic configuration type M (Milling)	FXSO 200 061	○	○	○	
Flexium 68	FXP2 100 200	-	-	●	Pack T or M required
<b>Axes, Spindles and Measurement</b>					
6 <sup>th</sup> axis/spindle	FXSO 100 006	-	-	○	
7 <sup>th</sup> and 8 <sup>th</sup> axes/spindles	FXSO 100 008	-	-	○	
9 <sup>th</sup> to 12 <sup>th</sup> axes/spindles	FXSO 100 012	-	-	○	
13 <sup>th</sup> to 16 <sup>th</sup> axes/spindles	FXSO 100 016	-	-	○	
17 <sup>th</sup> to 32 <sup>th</sup> axes/spindles	FXSO 100 032	-	-	○	
Analog interface 1 for axis, spindle or measurement input *	FXSO 100 373	○	○	○	(1)
Analog interface 2 for axis, spindle or measurement input *	FXSO 100 374	○	○	○	(1)
Handwheel interface 1 *	FXSO 100 375	○	○	○	(1)
Handwheel interface 2 *	FXSO 100 376	○	○	○	(1)
Handwheel interface 3	FXSO 100 377	-	-	○	
Handwheel interface 4	FXSO 100 378	-	-	○	
<b>Interpolated axes</b>					
5 <sup>th</sup> interpolated axis	FXSO 100 335	-	-	○	
6 <sup>th</sup> interpolated axis	FXSO 100 336	-	-	○	
7 <sup>th</sup> interpolated axis	FXSO 100 337	-	-	○	
8 <sup>th</sup> interpolated axis	FXSO 100 338	-	-	○	
9 <sup>th</sup> interpolated axis	FXSO 100 339	-	-	○	
<b>Multi-Channel functions</b>					
2nd channel	FXSO 100 392	-	○	○	
3rd + 4th channel	FXSO 100 394	-	-	○	
5th + 6th channel	FXSO 100 396	-	-	○	
7th + 8th channel	FXSO 100 398	-	-	○	
				●	standard option
				○	option
				-	not available

(1): No more than two devices connected on analogue ports X11 -X12 (Handwheel - Spindles- Axes)

# Flexium CNC System

CNC Hardware and Software

Configuration

Accessories Cables and Conectors

## Accessories Cables and Conectors

Description	Commercial reference	Flexium 6	Flexium 8	Flexium 68	Comments
<b>System Cables</b>					
Connection Flexium NCK - NUMDrive C					
<i>Mounted cable 0.5 m</i>	<b>FXHC 081 510</b>	○	○	○	
<i>Mounted cable 1 m</i>	<b>FXHC 081 511</b>	○	○	○	
<i>Mounted cable 2.5 m</i>	<b>FXHC 081 512</b>	○	○	○	
<i>Mounted cable 5 m</i>	<b>FXHC 081 513</b>	○	○	○	
<i>Mounted cable 10 m</i>	<b>FXHC 081 514</b>	○	○	○	
Clock/Synchro cable for Multi-NCK configuration					
<i>Mounted cable 0.2 m</i>	<b>FXHC 081 530</b>	-	-	○	
<i>Mounted cable 2.5 m</i>	<b>FXHC 081 531</b>	-	-	○	
<i>Mounted cable 5 m</i>	<b>FXHC 081 532</b>	-	-	○	
End of line termination	<b>FXHC 081 540</b>	-	-	○	
<b>Connector</b>					
Connector Kit X9 / X10	<b>FXHE181301</b>	○	○	○	
				●	standard
				○	option
				-	not available

# Flexium CNC System

## CNC Hardware and Software

### Software Options

#### Functions related to Axes and Spindles, Tool Management

#### Functions related to Axes and Spindles, Tool Management

Description	Commercial reference	Flexium 6	Flexium 8	Flexium 68
<b>Functions related to axes</b>				
Axis and interaxis calibration		●	●	●
Progressive acceleration		●	●	●
Anti-pitch correction		●	●	●
Linear and circular interpolation		●	●	●
High-speed cutting	FXSO 000 155	-	○	○
Dynamic operators in C	FXSO 000 249	-	○	○
Dynamic operators	FXSO 000 250	-	○	○
Duplicated and synchronized axes	FXSO 000 266	-	○	○
Inclined or tilt axes	FXSO 000 315	-	○	○
Cartesian / polar and cylindrical conversion	FXSO 000 340	-	○	○
NURBS (B-Spline) interpolation	FXSO 000 426	-	-	○
Tandem function	FXSO 000 453	-	○	○
Circular interpolation defined by three points	FXSO 000 497	-	○	○
Smooth polynomial interpolation	FXSO 000 499	-	○	○
Radial axis boring/milling function (Z-axis interpolation)	FXSO 000 514	-	○	○
Spline-Interpolation (G06, G48, G49)	FXSO 000 518	-	○	○
Programmable precision	FXSO 000 519	-	-	○
Spline interpolation with 3D curve smoothing (G104)	FXSO 181 706	-	○	○
<b>Functions related to spindles</b>				
Indexed spindle (M19)		●	●	●
Spindle speed range search		●	●	●
Spindle synchronization	FXSO 000 156	-	-	○
Axis/spindle synchronization (thread-cutting cycles)	FXSO 000 331	-	○	○
Rigid Tapping	FXSO 000 332	-	○	○
<b>Tool Management</b>				
Tool axis selection		●	●	●
Radius and length correction		●	●	●
Tool wear offset by the PLC		●	●	●
Table of 32 offsets		●	●	●
3D radius correction for milling	FXSO 000 400	-	○	○
Extension to 255 offsets	FXSO 000 401	-	○	○
5-axis tool offset	FXSO 000 411	-	-	○
			●	standard
			○	option
			-	not available

See page 23 for option packs

2

# Flexium CNC System

## CNC Hardware and Software

### Software Options

#### Canned Cycles, Programming, Operating Mode Functions

#### Canned Cycles, Programming, Operating Mode Functions

Description	Commercial reference	Flexium 6	Flexium 8	Flexium 68
<b>Machining Cycles</b>				
RTCP Function (G26)	FXSO 000 154	-	-	○
Tilted nozzle management	FXSO 000 404	-	○	○
Combined machine function (turning + milling)	FXSO 000 581	-	-	○
Automatic gear-alignment	FXSO 000 595	-	○	○
Milling cycles and standard pocket cycles	FXSO 000 695	-	-	○
Turning cycles	FXSO 000 696	-	-	○
Inclined plane machining	FXSO 000 914	-	-	○
Polygon-cutting cycles	FXSO 100 538	-	-	○
T probing cycles	FXSO 100 590	-	○	○
M probing cycles	FXSO 100 591	-	○	○
<b>Programming</b>				
Inch-metric conversion		●	●	●
PGP		●	●	●
Parametric programming		●	●	●
Scaling factor (G74)	FXSO 000 506	-	○	○
Angular program offset (ED)	FXSO 000 507	-	○	○
Transfer of active settings to the part program	FXSO 000 511	-	○	○
Structured programming, program stack and symbolic variables	FXSO 000 535	-	○	○
Building a profile table	FXSO 000 536	-	○	○
<b>Operating Mode Functions</b>				
Auto n/m function	FXSO 000 082	-	-	○
Emergency retract (G75)	FXSO 000 505	-	○	○
On-the-fly measurement acquisition (G10)	FXSO 000 520	-	○	○
Backtrack along stored path	FXSO 000 523	-	○	○
			●	standard
			○	option
			-	not available

See page 23 for option packs

# Flexium CNC System

## CNC Hardware and Software

### Software Packs

#### Overview

#### Software Packs Overview

	Description	Commercial reference	Flexium 6	Flexium 8	Flexium 68
T	Turning Pack	FXPA 000 555	○	○	○
M0	Basic Milling Pack	FXPA 000 560	○	○	○
M1*	Milling Pack	FXPA 000 561	-	-	○
M2*	Milling Pack	FXPA 000 562	-	-	○
M3*	Milling Pack	FXPA 000 563	-	-	○
HSC*	HSC Milling Pack	FXPA 000 564	-	-	○
AM*	Aluminium Machining Pack	FXPA 000 566	-	-	○
CUT3D	Water-jet, plasma cutting	FXPA 000 567	-	-	○
W1*	Woodworking Pack (5-axis milling)	FXPA 000 576	-	-	○
TR	Tool cutting and grinding Pack	FXPA 000 586	-	-	○
GS	Surface Grinding Pack	FXPA 000 587	-	○	○
GC	Cylindrical Grinding Pack	FXPA 000 588	-	○	○
SEGB	Gear Hobbing Pack 1	FXPA 000 596	-	○	○
FEGB	Gear Hobbing Pack 2	FXPA 000 597	-	○	○
				●	standard
				○	option
				-	not available

\* Pack M0 required



# Flexium CNC System

## CNC Hardware and Software

### Software Packs

#### Functions included in Packs

Description	Commercial Reference	Functions included in the packs														
		M0	M1*	M2*	M3*	HSC*	T	TR	SEGB	FEGB	GC	GS	W1*	AM*	CUT3D	
RTCP function (G26)	FXSO 000 154			●	●									●	●	●
High-speed cutting (UGV1)	FXSO 000 155					●								●		
Axis/spindle servoing (thread-cutting cycle)	FXSO 000 331						●				●					
Rigid Tapping	FXSO 000 332		●		●											
3D radius correction for milling	FXSO 000 400		●		●									●		
Extension to 255 tool offsets	FXSO 000 401	●	○	○	○	○								○	○	
5-axis tool correction for milling	FXSO 000 411			●	●	●								●		
Circular interpolation defined by 3 points	FXSO 000 497	●	○	○	○	○	●	●			●	●	○	○		
Smooth polynomial interpolation	FXSO 000 499					●										
Emergency retract (G75)	FXSO 000 505									●	●	●	●			
Scaling factor (G74)	FXSO 000 506	●	○	○	○	○	●				●	●	○	○		
Angular program offset (ED)	FXSO 000 507	●	○	○	○	○	●				●	●	○	○		
Transfer of active settings	FXSO 000 511	●	○	○	○	○	●	●	●	●	●	●	○	○		
Spline interpolation	FXSO 000 518					●										
Programmable precision	FXSO 000 519							●			●	●				
On-the-fly measurement acquisition (G10)	FXSO 000 520	●	○	○	○	○	●	●	●	●	●	●	○	○		
Structured programming	FXSO 000 535	●	○	○	○	○	●	●	●	●	●	●	○	○		
Milling cycles and standard pocket cycles	FXSO 000 695	●	○	○	○	○					●	●	○	○		
Turning cycles	FXSO 000 696						●				●					
Tilted plane machining	FXSO 000 914		●	●	●										●	
5-axis interpolation	FXSO 000 335			●	●			●					●	●		
Tilted head management	FXSO 000 404															●
2nd Chanel (multi function)	FXSO 100 398 + 392 394										●	●				
SEGB Macros	N/A									●						
FEGB Macros	N/A										●					

The options marked with a " ○ " are not included in the pack but will be activated by M0 or T which are prerequisite

# Flexium CNC System

## CNC Hardware and Software

### Flexium HMI Options, NUMtransfer

#### Flexium HMI and PLC Options, NUMtransfer

Flexium HMI is a PC based HMI (Human Machine Interface) for the Flexium NCK.

Description	Commercial reference	Flexium 6	Flexium 8	Flexium 68
<b>Flexium Suite</b> installed on all FS152i includes documentation and: Flexium HMI Flexium Tools Flexium 3D	<b>FXSW 282 189</b>	●	●	●
<b>Flexium HMI options</b>				
Symbolic names	<b>FXSW 282 113</b>	○	○	○
Extended Tool table	<b>FXSW 282 114</b>	○	○	○
Teach-IN		○	○	○
Extension for NUMROTOplus	<b>FXSW 282 122</b>	-	-	○
<b>NUMtransfer®</b> <i>includes:</i> Symbolic Names <b>FXSW 282 112</b> Extended Tool Table <b>FXSW 282 113</b>	<b>FXSW 282 200</b>	-	○	○
<b>NUMtransfer® Multi-NCK</b> <i>includes:</i> Symbolic Names <b>FXSW 282 112</b> Extended Tool Table <b>FXSW 282 113</b> Multi-NCK <b>FXSW 282 117</b>	<b>FXSW 282 201</b>	-	-	○
<b>Flexium 3D</b> <i>Available in two versions:</i> - Machine version - Office version (with dongle)				
3D Simulation for Turning T	<b>FXSW 282 150</b>	○	○	○
3D Simulation for Milling M	<b>FXSW 282 151</b>	○	○	○
<i>One of the two choices above is standard with the Office version. In the Machine version, the selection is according to the machine type</i>				
Simulation mixed T & M	<b>FXSW 282 152</b>	○	○	○
Simulation with material removal	<b>FXSW 282 153</b>	○	○	○
Simulation with collision detection	<b>FXSW 282 154</b>	○	○	○
Online simulation	<b>FXSW 282 155</b>	○	○	○
Flexium3D Dongle for the Office version	<b>FXHE 557 200</b>	N/A	N/A	N/A
<b>PLC options</b>				
1st CAN Interface	<b>FXSO 000 430</b>	○	○	●
2nd CAN Interface	<b>FXSO 000 432</b>	-	-	○
Multi NCK	<b>FXSW 282 117</b>	-	-	○
Extended NCK Access	<b>FXSW 282 124</b>	○	○	○
PLC Visualization <sup>1</sup>	<b>FXSW 282 160</b>	○	○	○
HMI Classic <sup>2</sup>	<b>FXSW 282 300</b>	○	○	○
Target Visualization <sup>3</sup>	<b>FXSW 282 302</b>	○	○	○
Web Visualization <sup>4</sup>	<b>FXSW 282 303</b>	○	○	○

<sup>1</sup> PLC Visualization allows for integrating PLC controlled pages in a frame of Flexium HMI

<sup>2</sup> HMI Classic: PLC controlled visualization displayed on a remote device

<sup>3</sup> Target visualization: PLC controlled visualization displayed on the same device than the one running the PLC. Contrary to the PLC visualization the screen are separated from Flexium HMI

<sup>4</sup> Web visualization: PLC controlled visualization displayed inside a browser on an external device

● standard  
○ option  
- not available

# Flexium CNC System

## CNC Hardware and Software

### Operation Panel PCs

#### FS152 Series

#### FS152 Series

For a detailed description of the panels (specifications and dimensions), see Chapter 3.

FXPC	15	2	R	N	2	H	C	R	0	0
<b>Display Unit</b>										
LCD 15"	15									
LCD 19"	19									
Box PC	00									
<b>Panel/mechanical variant</b>										
Variant		2								
<b>Display Sensor</b>										
Touch Screen resistive			R							
Touch Screen (proj.) capacitive			C							
No Sensor			N							
<b>Keyboard type</b>										
22 Function keys				F						
22 Function keys + Querty Keyboard				Q						
No keyboard, No function keys				N						
<b>IPC mother board, Processor</b>										
Performance level P1					1					
Performance level P2					2					
No IPC just panel					N					
<b>Mass memory type</b>										
HD (Hard Disk)						H				
SSD (Solid State Disc)						S				
CF (Compact Flash)						C				
No IPC, just panel						N				
<b>Option board</b>										
No fieldbus							N			
CAN							C			
CAN + NVRAM							D			
<b>Flexium RTS</b>										
No real time								N		
Real time								R		
<b>Spare number</b>									0	
<b>Spare number</b>										0

# Flexium CNC System

CNC Hardware and Software

Operation Panels

Accessories FS152 Series

## Accessories FS152 Series

Description	Commercial reference	Flexium all Platforms	Comments
<b>Easy Backup</b>			
<b>EasyBackup</b> <i>16GB Memory Stick™</i>	<b>FXHE 557 101</b>	○	
<b>FS152i – Cables</b>			
Connection FS152i - Flexium NCK			
<i>Mounted cable 0.5 m</i>	<b>FXHC 181 040</b>	○	
<i>Mounted cable 1 m</i>	<b>FXHC 181 041</b>	○	
<i>Mounted cable 2 m</i>	<b>FXHC 181 042</b>	○	
<i>Mounted cable 5 m</i>	<b>FXHC 181 043</b>	○	
<i>Mounted cable 10 m</i>	<b>FXHC 181 044</b>	○	
<i>Mounted cable 20 m</i>	<b>FXHC 181 045</b>	○	
<i>Mounted cable 30 m</i>	<b>FXHC 181 046</b>	○	
<b>FS152 – Common Characteristics</b>			
<i>Panel without PC, 15.1" LCD screen for the use with a standard or industrial PC, front USB</i>			
<b>FS152 - FK</b>	<b>FXPC 152 NFNN NN00</b>	○	
<i>22 function keys</i>			
<b>FS152 - FQ</b>	<b>FXPC 152 NQNN NN00</b>	○	
<i>22 function keys, 75-key Qwerty keyboard</i>			
		●	standard
		○	option
		-	not available

2

# Flexium CNC System

## CNC Hardware and Software

### Operation Panels

Machine Panels MP04, nPad, Handwheels

### Machine Panels P04, nPad, Handwheels

For a detailed description of the panels (specifications and dimensions), see Chapter 3.

Description	Commercial reference	Flexium all Platforms	Comments
<b>MP04 Machine Panel – Common Characteristics</b> <i>Connection to CNC via CAN</i>			
<b>MP04-W</b> <i>without Handwheel</i>	FXHE 558 110	○	
<b>MP04-H</b> <i>with Handwheel</i>	FXHE 558 120	○	
<b>Portable Handwheel HBA-Xc (RS422)</b>	FXHE 181 121	○	
<b>Portable Handwheel HBA-Xd (24 VDC)</b>	FXHE 181 122	○	
socket for portable handwheel	FXHE 181 310	○	
<b>nPad Wired Handheld Terminal</b> <i>Cable (with cable glands)</i>	NPAD052RE1SH0D1	○	
<b>nPad Terminal Connector</b>	NPADA001	○	
		●	standard
		○	option
		-	not available

# Flexium CNC System

CNC Hardware and Software

Panels

Accessories Machine Panels

## Accessories Machine Panels

Description	Commercial reference	Flexium all Platforms	Comments
<b>CAN Cable (no connectors, per meter)</b>			
PVC, purple, shielded in pairs	<b>FXHC 181 060</b>	○	
<b>CAN Connectors</b>			
CAN connector with axial outlet (for FS152i connection)	<b>FXHC 181 200</b>	○	
CAN connector with axial outlet 90°	<b>FXHC 181 201</b>	○	
CAN connector with axial outlet 90° and connection for programming device	<b>FXHC 181 202</b>	○	
		●	standard
		○	option
		-	not available

2

# Flexium CNC System

## CNC Hardware and Software

### NUM EtherCAT

#### Gateways and Terminals

#### Gateways and Terminals

For a detailed description see Chapter 3.

Description	Commercial reference	all Platforms	Task / Connection Technology
<b>Gateway</b>			
EtherCAT gateway	CTMG1100	○	Connects EtherCAT with the EtherCAT terminal block
EtherCAT extension	CTMG1110	○	The terminal, used like bus end terminal, offers the option of connecting another terminal block via Ethernet cable RJ45
<b>Digital Input</b>			
4-channel digital input terminal 24 V DC, 3 ms	CTMT1004	○	2-wires connection
8-channel digital input terminal 24 V DC, 3 ms	CTMT1008	○	1-wire connection
HD EtherCAT Terminal, 4-channel digital input 24 V DC	CTMT1804	○	3-wire connection
HD EtherCAT Terminals, 16-channel digital input 24 V DC	CTMT1809	○	1-wire connection
<b>Digital Output</b>			
4-channel digital output terminal 24 V DC, 0.5 A	CTMT2004	○	2-wires connection
8-channel digital output terminal 24 V DC, 0.5 A	CTMT2008	○	1-wire connection
HD EtherCAT Terminal, 16-channel digital output 24 V DC, 0.5 A	CTMT2809	○	1-wire connection
2-channel relay output terminal	CTMT2612	○	Relay output
<b>Analogue Input</b>			
2-channel analog input terminals -10...+10 V, differential input, 16 bits	CTMT3102	○	2 (differential) Inputs
2-channel analog input terminal 4...20 mA, differential input, 16 bits	CTMT3122	○	2 (differential) Inputs
2-channel analog input terminals 0...10 V, single-ended, 16 bits	CTMT3162	○	2 (single-ended) inputs
2-channel input terminal PT100 (RTD) for 2- or 3-wire connection	CTMT3202	○	2 Inputs, 2- or 3 wire (default 3-wire) connection
<b>Analogue Output</b>			
2-channel analog output terminal 0...10 V, 16 bits	CTMT4102	○	2 (single ended) Outputs, 2-wire
2-channel analog output terminal 4...20 mA, 16 bits	CTMT4122	○	2 (single ended) Outputs, 2-wire
2-channel analog output terminal -10...+10 V, 16 bits	CTMT4132	○	2 (single ended) Outputs, 2-wire
<b>Communication</b>			
Serial interface 1 x RS232	CTMT6001	○	Terminal contact, 2 (1/1) channels, TxD and RxD, full duplex
Serial interface 1 x RS422/RS485	CTMT6021	○	Terminal contact, TxD and RxD, full/half duplex
<b>System Terminals</b>			
End cap	CTMT9011	○	Each assembly must be terminated at the right hand end with an bus end cap
Potential supply, 24 V DC	CTMT9100	○	Potential supply terminal
Potential supply, 24 V DC, with diagnostics	CTMT9110	○	Potential supply terminal with diagnostics
Power supply terminals for E-bus	CTMT9410	○	24V Input, to refresh E-bus
<b>Encoder Terminals</b>			
Incremental encoder interface, differential inputs	CTMT5101	○	Incremental encoder interface RS485
1-channel incremental encoder interface	CTMT5151	○	incremental encoder interface 24 V DC, EN 61131-2, type 1, "0": < 5 V DC, "1": > 15 V DC, typ. 5 mA
NUM EtherCAT product identification:		●	standard
CTMx: Communication to machine		○	option
CTMG: Gateway		-	not available
CTMT: Terminals			

# Flexium CNC System

CNC Hardware and Software

NUM EtherCAT

Gateways and Terminals

## Technical Documentation

Description	Commercial reference	Flexium all Platforms	Comments
<b>Technical Documentation</b>			
<i>Each CNC includes a CD-ROM containing the basic documents.</i>			
<b>CD-ROM - Basic Documents</b>	<b>FXDO 100 815</b>	○	
<i>Includes all manuals in English</i>			
AMOMAN012 NUMDrive C Installation manual			EN
AMOMAN012 NUMDrive C Parameters manual			EN
M00009 Flexium Installation manual			EN/FR
M00010 Flexium Commissioning manual			EN
M00012 Flexium CANopen Axes			EN
M00013 Easy Backup user manual			EN
M00016 Flexium HMI Operator Manual Add. Functions			EN/DE
M00017 Flexium Programming Manual			EN/FR/DE
M00018 Flexium Programming Manual			EN/FR/DE
M00020 Flexium Extended Programming Manual			EN/DE
M00025 BHX and BPX Motors reference guide			EN
M00026 Flexium Extended NCK Access			EN
M00027 Cabinet lay-out and EMC Wiring Guide			EN
M00029 Flexium 3D manual			EN
M00032 NUM EtherCAT terminals CTMG and CTMT - Installation manual			EN
		●	standard
		○	option
		-	not available

2





# 3 Flexium CNC System Completion

---

Peripheral Devices

Table of Contents

---

	Page
<b>Panels</b>	<b>35</b>
General	35
Operator Panels FS152 Series	36
Operator Panels FS152 Series Dimensions and Cutout	38
NUM Industrial Box PC	39
Machine Panels MP04	40
Easy Backup	40
Machine Panels MP04	41
Portable Handwheel HBA-X	41
<b>Panels</b>	<b>42</b>
nPad - Mobile Operator Panel	42
<b>NUM EtherCAT</b>	<b>46</b>
Introduction, System Structure, NUM EtherCAT Terminal Performance	46
Technical Data Gateways	47
Technical Data Terminals	48



# Flexium CNC System Completion

## Peripheral Devices

### Panels

#### General

#### General

NUM has developed control panels for Flexium with a 15" flat screen and either with or without an integrated industrial PC. They function as a powerful platform for the HMI and enable you to operate it simply and logically.

Depending on the application, you can choose one of two technically distinct power levels:

- Equipped with Windows Embedded, flash memory cards and a specific motherboard, the first variant comes without moving parts such as a hard disk or fan
- The second variant comes with Windows Full Version and a hard disk and is used when higher performance and more storage space are required
- Full network and Internet-capability is intrinsic to both performance levels

Depending on the application, you can choose one of three physical user interfaces:

- With 22 large function keys
- With 22 large function keys and an expanded QWERTY keyboard
- With Touch Screen

The FS152-FK (keyboard option F) and FS152-FQ (keyboard option Q) share the looks and the physical dimensions with the above panels but have no integrated PC. They are designed for the use with an external computer.

The display quality of their 15.1" screen makes them very legible even in poorly-lit environments. Compact, they are also very rugged and sealed (IP 65) for compatibility with the most severe industrial environments.

The ideal extension to all models are the machine panels MP04.



# Flexium CNC System Completion

## Peripheral Devices

### Panels

#### Operator Panels FS152 Series

#### Operator Panels FS152 Series

FS152 Series	FS 152i-FK						FS 152i-FQ					
Type	22 Function Keys						22 Function Keys, Qwerty Keyboard					
Version	P1 SD NR	P1 SD RT	P1 SD RT CAN	P2 HD NR	P2 HD RT	P2 HD RT CAN	P1 SD NR	P1 SD RT	P1 SD RT CAN	P2 HD NR	P2 HD RT	P2 HD RT CAN
Panel type	Active panel with integrated PC											
Display unit	LCD 15", protected by 2.3mm Siflex TV glass, 16.9 million colors											
Use	These panels are especially developed for the use with Flexium HMI.											
CNC/panel link	TCP/IP											
Machine panel	MP04 (option)											
CPU	Atom D510 1.66 GHz DualCore			i5 M520 2.4 GHz DualCore			Atom D510 1.66 GHz DualCore			i5 M520 2.4 GHz DualCore		
Mass storage	8 GB SSD			Hard disk ≥ 260 GB			8 GB SSD			Hard disk ≥ 260 GB		
RAM	1GB			2GB			1GB			2GB		
Operating system	Windows Embedded POSReady			Windows XP Professional			Windows Embedded POSReady			Windows XP Professional		
Graphic card	P1: Embedded GEN3.5+ GFX Core / P2: Intel® HD Graphics											
Operation	22 Function Keys						22 Function Keys, Qwerty Keyboard					
Communication												
Ethernet	3	3	3	3	3	3	3	3	3	3	3	3
Real Time Ethernet		●	●		●	●		●	●		●	●
CAN			1 + 1 **			1 + 1 **			1 + 1 **			1 + 1 **
NVRAM			●			●			●			●
USB 2.0 front	●	●	●	●	●	●	●	●	●	●	●	●
USB 2.0 rear	●	●	●	●	●	●	●	●	●	●	●	●
Serial interface				●	●	●				●	●	●
DVI interface				●	●	●				●	●	●
PS/2												
VGA	●	●	●	●	●	●	●	●	●	●	●	●
Power supply voltage	24 VDC											
Power consumption	~50 W			~60 W			~50 W			~60 W		
Protection class	IP65 front - IP54 to cabinet - IP20 rear											
EMC	CE conform											
Operating temperature	0° to 45°											
Storage temperature	-20° to +60° C											
Relative humidity	10 to 90%, without condensation											
Overall dimensions (L x H x D*), mm	410 x 330 x 75						410 x 400 x 75					
Weight	6.1 kg						6.5 kg					
Com. ref. FXPC 152 xxxx ....	NF1S NN00	NF1S NR00	NF1S CR00	NF2H NN00	NF2H NR00	NF2H CR00	NQ1S NN00	NQ1S NR00	NQ1S CR00	NQ2H NN00	NQ2H NR00	NQ2H CR00

\* = depth behind panel

\*\* = 1 x CAN standard, 1 x CAN optional, NVRAM optional

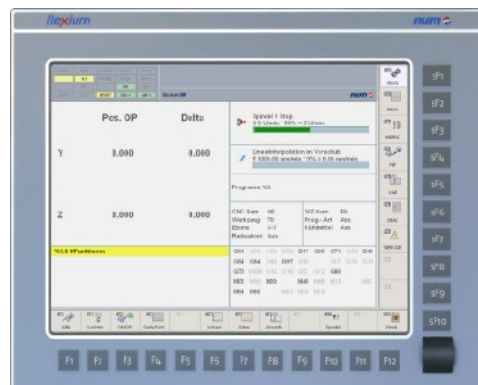

# Flexium CNC System Completion

## Peripheral Devices

### Panels

#### Operator Panels FS152 Series

#### Operator Panels FS152 Series

FS152 Series	FS152i-TS						FS152-FK	FS152-FQ
Type	Touch Screen resitive						22 Function Keys	22 Function Keys, Qwerty Keyboard
Version	P1 SD NR	P1 SD RT	P1 SD RT CAN	P2 HD NR	P2 HD RT	P2 HD RT CAN		
Panel type	Active panel with integrated PC						Passive panel for external PC	
Display unit	LCD 15", protected by 2.3mm Siflex TV glass, 16.9 million colors							
Use	These panels are especially developed for the use with Flexium HMI.							
CNC/panel link	TCP/IP							
Machine panel	MP04 (option)							
CPU	Atom D510 1.66 GHz DualCore			i5 M520 2.4 GHz DualCore			External PC required	
Mass storage	8 GB SSD			Hard disk ≥ 240 GB				
RAM	1GB			2GB				
Operating system	Windows Embedded POSReady			Windows XP Professional			-	
Graphic card	P1: Embedded GEN3.5+ GFX Core P2: Intel® HD Graphics						Depends on PC used	
Operation	Touch Screen						22 Function Keys	22 Function Keys, Qwerty Keyboard
Communication								
Ethernet	3	3	3	3	3	3	Depends on PC used	
Real Time Ethernet		●	●		●	●	Depends on PC used	
CAN			1 + 1**			1 + 1**	Depends on PC used	
NVRAM			●			●	Depends on PC used	
USB front	●	●	●	●	●	●	●	●
USB rear	●	●	●	●	●	●	●	●
Serial interface				●	●	●	-	-
DVI interface				●	●	●	●	●
PS/2							-	-
VGA	●	●	●	●	●	●	-	-
Power supply voltage	24 VDC							
Power consumption	~50 W			~60 W			25 W	
Protection class	IP65 front - IP54 to cabinet - IP20 rear							
EMC	CE conform							
Operating temperature	0° to 45°							
Storage temperature	-20° to +60° C							
Relative humidity	10 to 90%, without condensation							
Overall dimensions (L x H x D*), mm	410 x 330 x 75						410 x 330 x 65	410 x 400 x 65
Weight	6.2 kg						4.8 kg	5.4 kg
Com. ref. FXPC 152 xxxx ....	RN1S NN00	RN1S NR00	RN1S CR00	RN2H NN00	RN2H NR00	RN2H CR00	NFNNNN00	NQNNNN00

\* = depth behind panel

\*\* = 1 x CAN standard, 1 x CAN optional, NVRAM optional; for Flexium 68 only

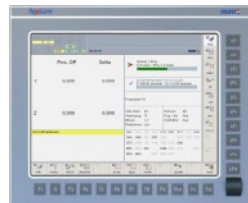
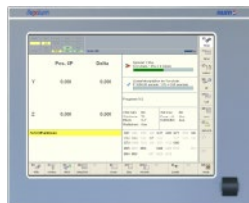

# Flexium CNC System Completion

## Peripheral Devices

### Panels

#### Operator Panels FS152 Series Dimensions and Cutout

#### Operator Panels FS152 Series Dimensions and Cutout

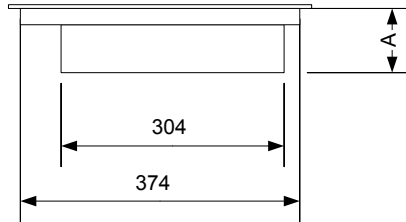

FS152-FQ, FS152i-FQ

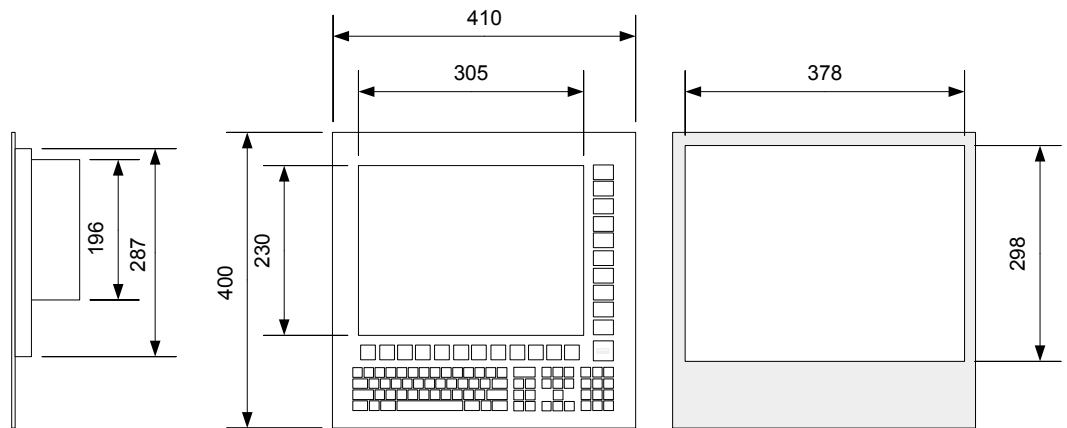

FS152-FK, FS152i-FK, FS152i-TS

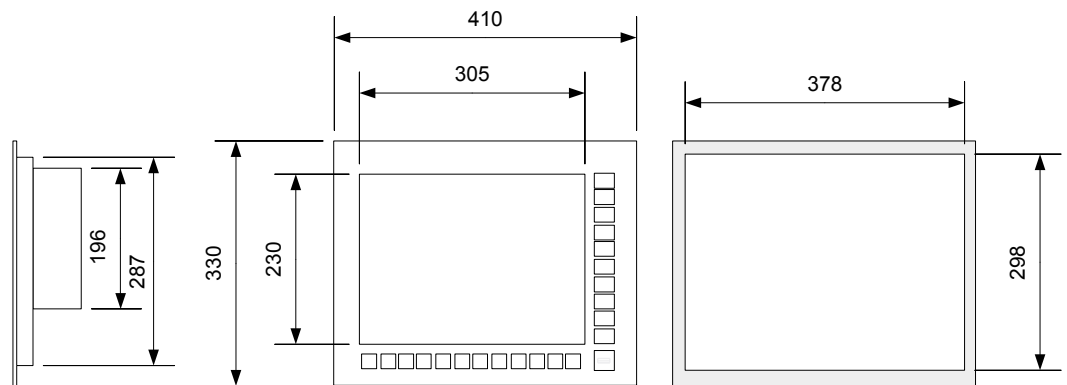

Measure "A"	<b>FS152i ...</b> 73 mm	<b>FS152-FK, FS152-FQ</b> ~45 mm incl. ground terminal
-------------	----------------------------	---



# Flexium CNC System Completion

## Peripheral Devices

### Panels

#### NUM Industrial Box PC

#### NUM Industrial Box PC

NUM Industrial Box PC has two properties:

- Role as complete DPLC (PLC function only)
- Role as inexpensive industrial PC with PLC

#### DPLC-PLC Function only

Systems with extensive demand in system performance e.g. for CAD/CAM can be configured with an external PC and a passive Flexium operating panel FS152. The required PLC functions are handled by the external Box PC (with Dedicated PLC) linked by Ethernet to the external PC.

#### Industrial PC with PLC

Another target of this product is to cover all customer requests for a 3rd party or office PCs. So NUM recommends to these customers to use a fully tested PC device regarding real-time performance and requirements, no missing interrupts and deterministic execution time.

#### Specifications

FXPC002NN1CxR00	Description
CPU	Intel® Atom™ CPU D525 @ 1.80 GHz Dual Core (NEXCOM 608)
Mass Storage	CF 8 GB
RAM	2 GB
OS	WES 2009
Ethernet	3x Gigabit LAN / RTE
CAN	2 (as option)
USB	2 ext.
COM / VGA / PS2 / DVI	3 / 1 / mouse + keyboard / 0
Power supply	24VDC (+15%/-15%) / 1A
Power consumption	Approx. 14W
Protection fuse	Internal fuse 2A/250V - Ø 5mm x 20mm
Cooling type	Internal (with fan)
Degree of protection	IP00
Pollution degree	2
Environmental installation conditions	At least of IP54 degree protection
Operating temperature range	From 0 to +40°C
Storage temperature	From -40°C to +80°C
Relative humidity degree	Max. 75% without condensation
Overall dimensions	50 x 355 (410) x 206 mm
W x H x D	
Weight approx.	2.4kg

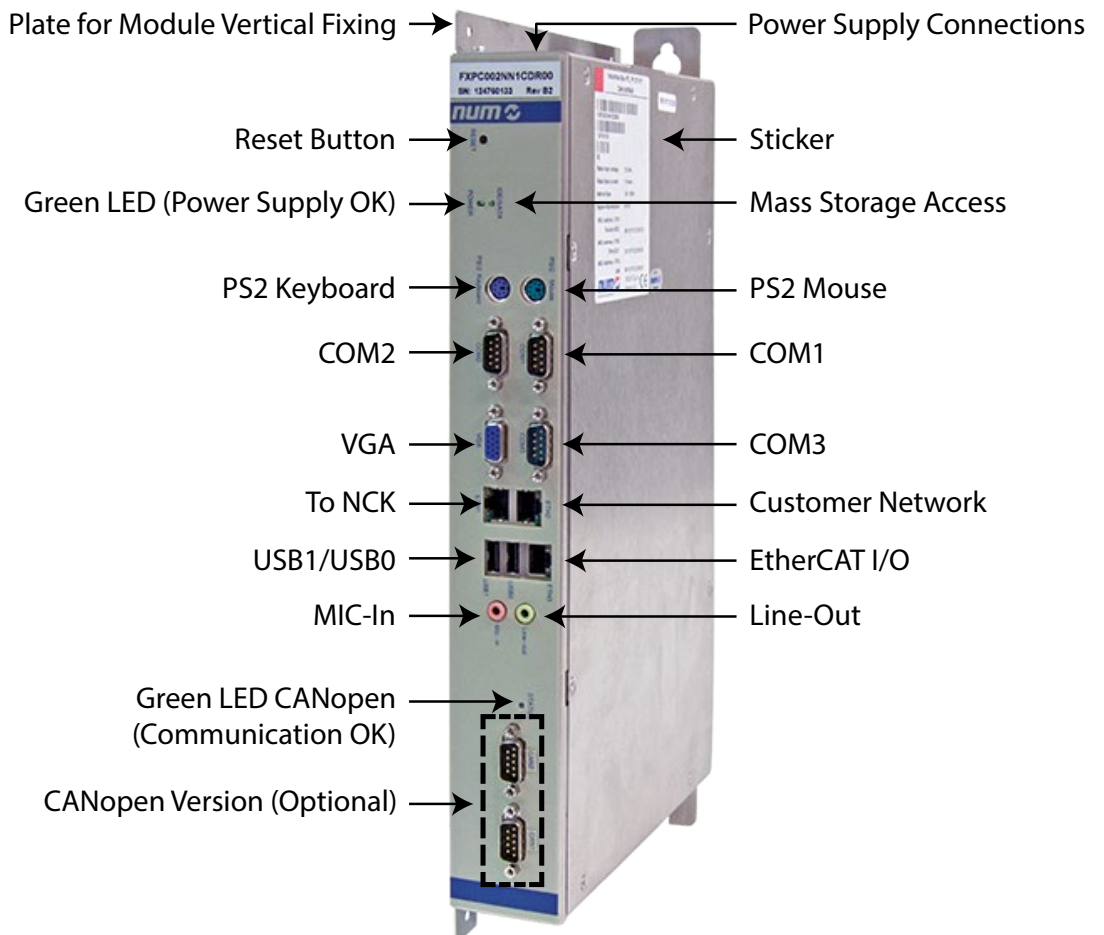



# Flexium CNC System Completion

---

## Peripheral Devices

### Panels

#### Machine Panels MP04

#### Easy Backup

---

### Easy Backup

Easy Backup is the simple and fast backup & recovery solution for the FS151i and FS152i. With this software, images from individual partitions or entire data carriers of the FS151i or FS152i can, directly and without any complicated installation, be generated on the Easy Backup USB memory stick with 16GB. Should Windows suddenly no longer be able to run, a data carrier image is always readily available for this emergency. The FS151i or FS152i is then simply booted from the USB stick and, with the aid of the Disaster Recovery function, restored in no time. EasyBackup thus increases the availability of FS151i and FS152i and of all the machines thereby controlled as well.

Advantages over other image versions:

- Backup possible during running operation
- Does not need to be installed on the PC (no undesired side effects)
- Bootable USB stick -> no DVD or other drive required
- Fast and easy restoration of the system -> reduces downtime of the machine in the event of faults
- Simple backup can also be performed by end users
- Software and image all on one stick connected directly to the machine



# Flexium CNC System Completion

## Peripheral Devices

### Panels

#### Machine Panels MP04

#### Portable Handwheel HBA-X

### Machine Panels MP04

This panel is used for control of manual movements, production initiation and intervention during machining. Two versions are available:

- Machine Panel MP04–W, without handwheel (P/N FXHE 558 110)
- Machine Panel MP04–H, with handwheel (P/N FXHE 558 120)

It includes:

- 55 configurable keys with LEDs
- 2 potentiometers for spindle speed and feed rate override
- 1 handwheel (FXHE 558 120 only)
- 1 emergency stop button
- 1 three-position key switch
- 3 controls: Cycle start, Cycle stop and Reset
- 5 keys for additional functions with LEDs

The MP04 has to be connected via CAN. For the handwheel, which is mounted on MP04 machine panel, exists two connection possibilities. Either connected via CAN or directly hooked up at CNC.

#### Characteristics

- Nominal voltage (external power supply) 24 VDC; +20%; -15%
- Minimum/maximum tolerance 20.8 V to 28.8 V
- Power consumption 15 W
- Outputs in use 40 W max
- Outputs not in use 5 W max
- Maximum current rating 500 mA
- Weight 1.2 kg
- Max. distance from CNC 40 m
- Max. distance from CNC via CAN limits of CAN

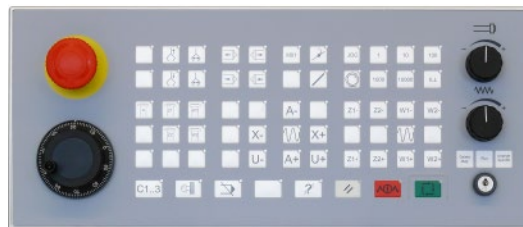
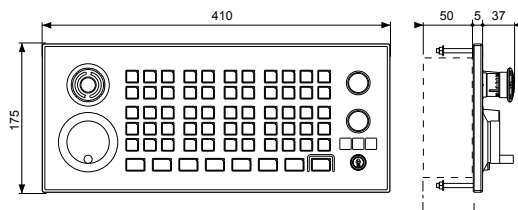

### Portable Handwheel HBA-X

FXHE181121 for HBA-Xc (5V)  
FXHE181122 for HBA-Xd (24V)

The portable handwheel HBA-X for Flexium provides a number of operation functions:

- Axis selection
- Hand mode and speed selection
- Movements forward/backward and speed override
- Hand wheel
- 3 step acknowledge button (dead-man's button)
- Connection to the system for Flexium 6, 8 and 68 (maximum cable length to the NCK approximately 5m – please ask NUM for details).
- Buttons and switches: via I/Os
- Handwheel: directly to the Flexium NCK
- Dead-man's button: into the safety circle

#### CAN

Connection to the Flexium 68 system can also be made using CAN. This requires one or more CAN connection devices (including a counter module XION 84082) and allows hot-plugging of the HBA-X without affecting the machine. For CAN connectivity Portable Handwheel HBA-Xd is required.



# Flexium CNC System Completion

## Peripheral Devices

### Panels

#### nPad - Mobile Operator Panel

#### nPad - Mobile Operator Panel

NUM provides a mobile operator panel with integrated 5" TFT touch screen monitor called nPad. For machine operating the flexible panel provides 19 soft-keys, 2 override potentiometers, handwheel, BCD selector as well as E-Stop and dead man button. Two versions will be marketed:

- nPad wired with Ethernet communication for HMI and discrete wires for E-Stop, enabling device, BCD selector
- nPad wireless with Wi-Fi (Ethernet) communication for HMI and BlueTooth for safety related data

For an easy and machine oriented control of the kinematics in manual mode this portable and wireless handheld is developed. In contrast to existing handwheel panels HBA-Xc and HBA-Xd NUM nPad terminal is appared with a 5" TFT touch screen monitor displaying a programmable screen user interface.

The mobile operator panel nPad is equipped with WinCE 6.0 and CoDeSys HMI runtime environment. A communication library permits the access to nPad Hardware for handwheel, touch buttons, selector, overrides and other signals.

For graphical editor and programming, design patterns and system integration only one tool is needed: Flexium Tools, the same as for NCK configuration and PLC programming is used. Subsequently advanced features such as multi-language support in visualization are present. Simulation of the graphical supported touch panel software could be done even without nPad hardware.

A customized application example (CoDeSys HMI) provided by NUM puts the OEM in the position, not to start from the scratch.

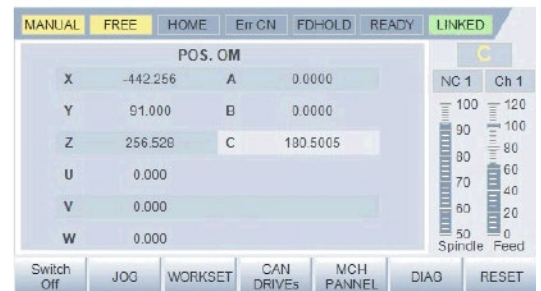

# Flexium CNC System Completion

## Peripheral Devices

### Panels

#### nPad - Mobile Operator Panel

#### nPad - Mobile Operator Panel

The wired/wireless nPad handheld is easily adaptable to Flexium component structure.

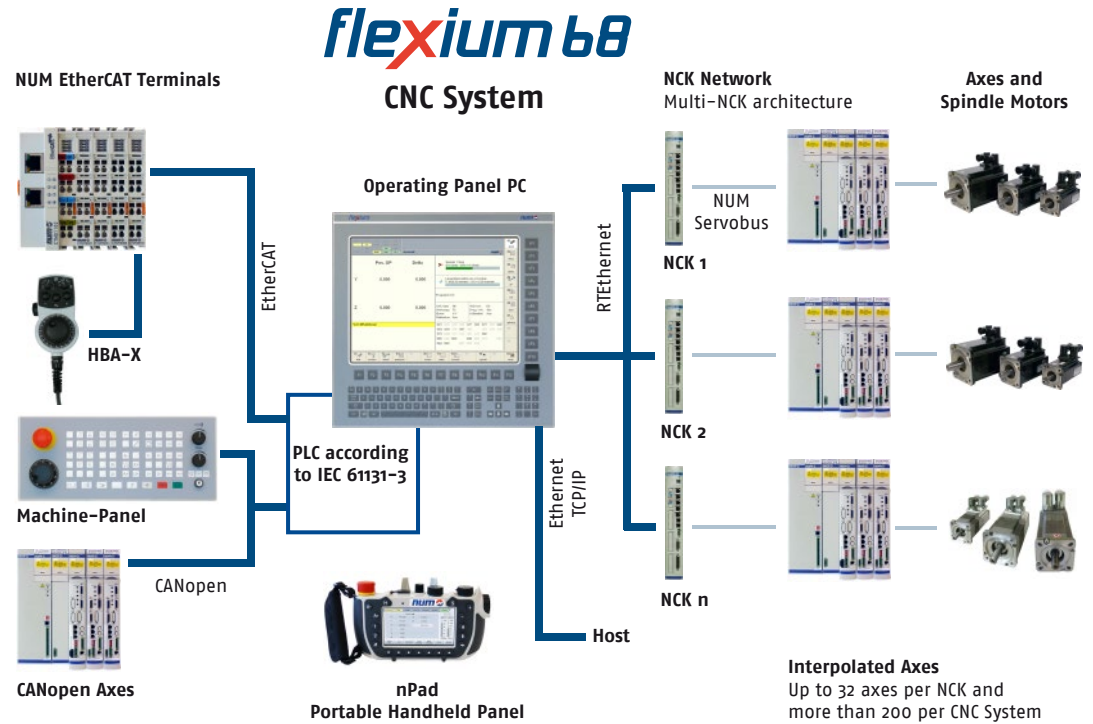

3

## Product Overview





# Flexium CNC System Completion

## Peripheral Devices

### Panels

#### nPad - Mobile Operator Panel

The following components belong to the nPad wired offer

Description	Part number	Picture
nPad wired handheld terminal	NPAD052RE1SH0D1	
nPad terminal connector	NPADA001	

## nPad Characteristics

5" TFT touch screen monitor	resistive, 16:9, resolution 480*272
Certified Safety interface	<ul style="list-style-type: none"> <li>E-Stop pushbutton certified according to SIL 2 / PL d</li> <li>Enabling Device certified according to SIL 2 / PL d</li> <li>State selector (up to 16 positions) certified according to SIL 1 / PL c</li> </ul>
Data interface	<ul style="list-style-type: none"> <li>2 potentiometers</li> <li>Dedicated keys (Examples: Start, Hold, Jog+, Jog-, Axis+, Axis-)</li> <li>Programmable function keys. Functions fully user defined</li> </ul>
Dimensions	220*130*50
Weight	650 grams
Power Supply	10-30 VDC
Degree of Protection	IP65
Magnets	on back side to append the terminal

# Flexium CNC System Completion

## Peripheral Devices

### Panels

#### nPad - Mobile Operator Panel

#### nPad hand held terminal coding

	NPAD	05	2	R	E	1	S	H	0	D	1
<b>Display Unit</b>											
LCD 05"		05									
<b>Panel/mechanical variant</b>											
Variant			2								
<b>Display Sensor</b>											
Touch Screen resistive				R							
<b>Connection technology</b>											
Wired (Ethernet + wires)					E						
Wireless (Wi-Fi + BlueTooth)					W						
<b>Processor performance</b>											
Performance level P1						1					
<b>Safety functions</b>											
E-Stop, Enabling Device and State selector							S				
<b>Handwheel</b>											
H								H			
<b>Options</b>											
Standard									0		
<b>Cable length</b>											
Wireless version										0	
10 m											D
<b>Cable termination (for wired version only)</b>											
Wireless version											0
Cable gland and free wires											1

Additional options and cable terminations are foreseen, but not yet available.

3

# Flexium CNC System Completion

---

## Peripheral Devices

### NUM EtherCAT

#### Introduction, System Structure, NUM EtherCAT Terminal Performance

---

#### Introduction

NUM provides a comprehensive range of most common I/O components based on EtherCAT technology (EtherCAT = Ethernet for Control Automation Technology). It is the real-time Ethernet technology standardized by EtherCAT Technology Group. The EtherCAT fieldbus is well proven and in compare to CAN/CANopen faster.

NUM EtherCAT terminal is a modular system with different configurable devices:

- Gateway module CTMG1100 / gateway extension CTMG1110
- Digital and analog I/O module CTMTxxxx
- Technological modules CTMTxxxx

#### System Structure

The machine builder creates its own configuration made of a mixed combination of different devices realized in topologies like star, tree and line. For each line up a gateway is needed, which receives the EtherCAT field bus and propagate the message to the different devices by means of internal E-bus. To close the bus, end cap terminal is needed. Since up to 65.535 devices can be connected, the size of the network is almost unlimited. Distance between gateways is up to 100m.

The robust housing, secure contacts and the secure solidity built electronics are prominent features of NUM components. The electronic terminal blocks are attached to the EtherCAT Gateway on a standard DIN rail.

A clearly arranged connection panel with LEDs for status display and push-in contact labels ensures clarity in the field. 3-wire conductors with an additional connection for a protective conductor, enable direct connection of sensors and actuators.

#### NUM EtherCAT Terminal Performance

EtherCAT reaches new dimensions in network performance. Protocol processing is purely hardware-based through an FMMU chip in the terminal and DMA access to the network card of the master.

With EtherCAT, a communication technology is available that matches the superior computing capacity of modern industrial PC. The bus system is no longer a bottleneck of the control concept and its technology principle is scalable and not bound to the baud rate of 100 MBaud full duplex – extension to GB Ethernet is possible. Average update time of 256 digital I/Os is done in 11 micro seconds. Data transfer medium is standard Ethernet cable CAT5.



# Flexium CNC System Completion

## Peripheral Devices

### NUM EtherCAT Technical Data Gateways

#### Technical Data Gateways

Technical Data	CTMG1100	CTMG1110
<b>Task within EtherCAT system</b>	coupling of EtherCAT Terminals to 100BASE-TX EtherCAT networks	conversion of the E-bus signals to 100BASE-TX Ethernet for extension of the EtherCAT network
<b>Data transfer medium</b>	Ethernet/EtherCAT cable (min. CAT 5), shielded	
<b>Distance between stations</b>	100 m (100BASE-TX)	
<b>Number of EtherCAT Terminals</b>	up to 65,534	
<b>Protocol</b>	EtherCAT	any EtherCAT protocol
<b>Delay</b>	approx. 1 µs	
<b>Data transfer rates</b>	100 Mbaud	
<b>Configuration</b>	not required	
<b>Bus interface</b>	2 x RJ 45	1 x RJ 45
<b>Power supply</b>	24 V DC (-15 %/+20 %)	from E-bus
<b>Input current</b>	70 mA + (total E-bus current)/4	
<b>Current supply E-bus</b>	2000 mA	
<b>Current consumption E-bus</b>		typ. 130 mA
<b>Power contacts</b>	24 V DC max./10 A max.	
<b>Dimensions (W x H x D)</b>	44mm x 100mm x 68mm	
<b>Electrical isolation</b>	500 V (supply voltage/Ethernet)	
<b>Operating/storage temperature</b>	0...+55 °C/-25...+85 °C	
<b>Relative humidity</b>	95 %, no condensation	
<b>Vibration/shock resistance</b>	conforms to EN 60068-2-6/EN 60068-2-27	
<b>EMC immunity/emission</b>	conforms to EN 61000-6-2/EN 61000-6-4	
<b>Protect. class/installation pos.</b>	IP 20/variable	
<b>Approvals</b>	CE, UL, Ex	

3





# Flexium CNC System Completion

## Peripheral Devices

### NUM EtherCAT

#### Technical Data Terminals

#### Technical Data Terminals

For more detailed technical description of NUM EtherCAT terminals CTMG and CTMT regarding please use reference manual M00032EN-00.

Remark: (almost) each CTMT-terminal has the same dimension.

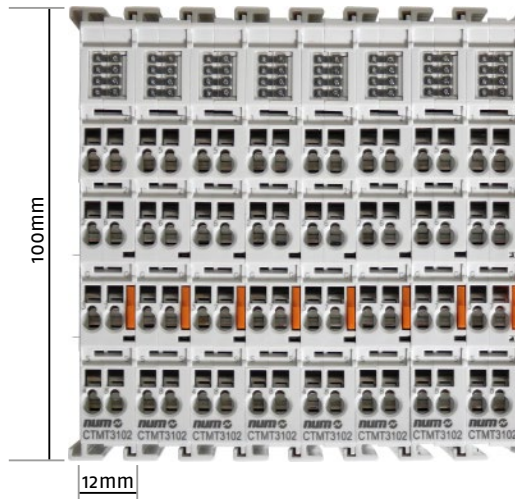

Note:

The mentioned terminal devices above are available on stock. For particular logic components please contact your local NUM NTC for further detailed information and availability.

#### System Structure

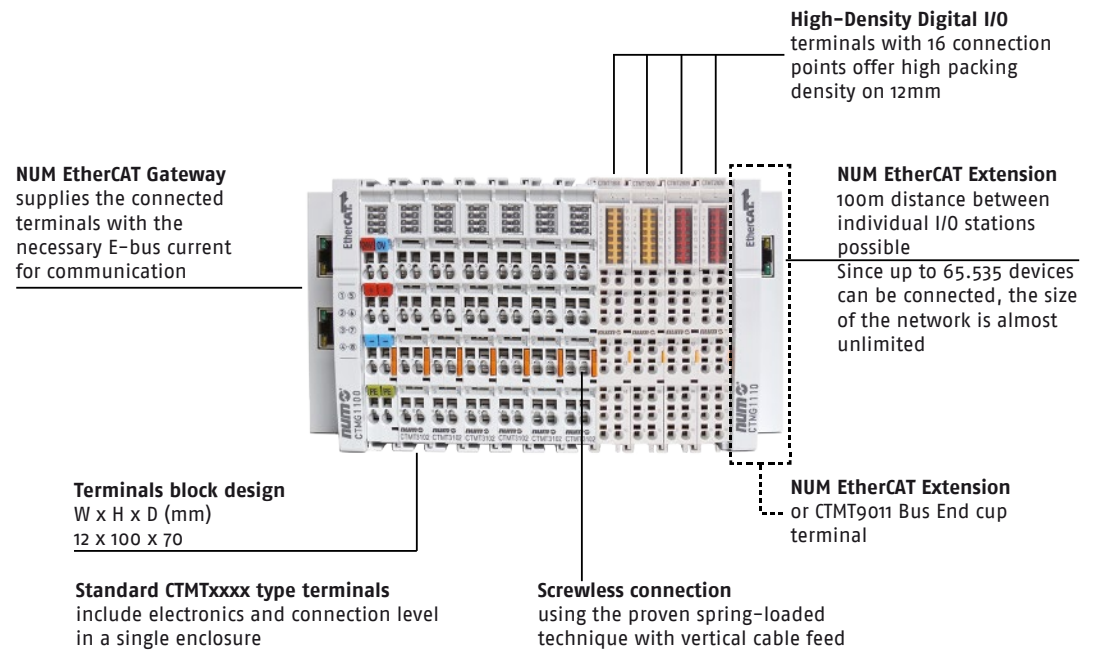

# 4 Flexium CNC System Software

## Functional Specifications

### Table of Contents

	Page
<b>System Architecture</b>	<b>51</b>
Functional Block Diagram	51
<b>System Integration and Customization</b>	<b>52</b>
Flexium Suite	52
Flexium Tools	53
Flexium Tools	54
Flexium Tools: PLC Programming	55
CNC/PLC Exchange Area	56
Flexium SDK	57
<b>Human Machine Interface</b>	<b>58</b>
Flexium HMI	58
Options	59
System Requirements	60
<b>Servosystem</b>	<b>61</b>
Flexium CNC System	61
High-Level Functions	61
NUMcoss - an additional component of High Speed Cutting (HSC)	62
<b>Axes</b>	<b>63</b>
CNC, Linear, Rotary Axes, Positioning, and Interpolated Axes	63
Interpolation: Linear, Circular, Smooth Polynomial, Spline, NURBS	64
Inclined, Tilt, Duplicated, and Synchronized Axes	65
Multichannel Functions, Calibration, Compensations	65
Programmable Precision, Inch/Meter Units	66
<b>Spindle</b>	<b>67</b>
Automatic Spindle Speed Range Search, Indexing, Synchronization	67
Rigid Tapping, Constant Surface Speed, Thread Cutting	67
C Axis and Coordinate System Conversions, Axis/Spindle Synchronisation	68
<b>Tool Management</b>	<b>69</b>
Tool Axis Selection, Tool Wear Offsets, Turning Tool Offsets	69
Milling Tool Offsets, 3D Tool Offsets, Dynamic Tool Offsets by the PLC	70
<b>Machining Cycles</b>	<b>71</b>
Milling and Pocket Cycles, 3D Workpiece Position Compensation,	71
Probing Cycles, Inclined Plane Machining	71
<b>Machining Cycles</b>	<b>72</b>
Milling and Pocket Cycles, 3D Workpiece Position Compensation,	72
Probing Cycles, Inclined Plane Machining	72
RTCP, Auto n/m Function, HS Precision Contours, Radial Axis Boring/Milling	73
Functions: Combined Machine, Polygon Cutting	74
Cycles: Turning, Customized, Probing for Lathe	74
<b>Program Interrupts</b>	<b>75</b>
On-the-Fly Measurement Acquisition, Backtrack, Emergency Retraction	75
<b>Part Programming</b>	<b>76</b>
Part Program, Resident Macros, Manual Input, Drip Feed Mode	76
Datum Shifts, Dynamic Software Switches, ISO/EIA Language	77
Subroutines, Parametric/Structured Programming, Contour Table	78
Transfer of Active Settings, Scaling Factor, Programmed Angular Offset	78
Index Table Eccentricity Function, Profile Geometry Programming	79



# Flexium CNC System Software

## Functional Specifications: Functional Block Diagram

### System Architecture Functional Block Diagram

#### Functional Block Diagram

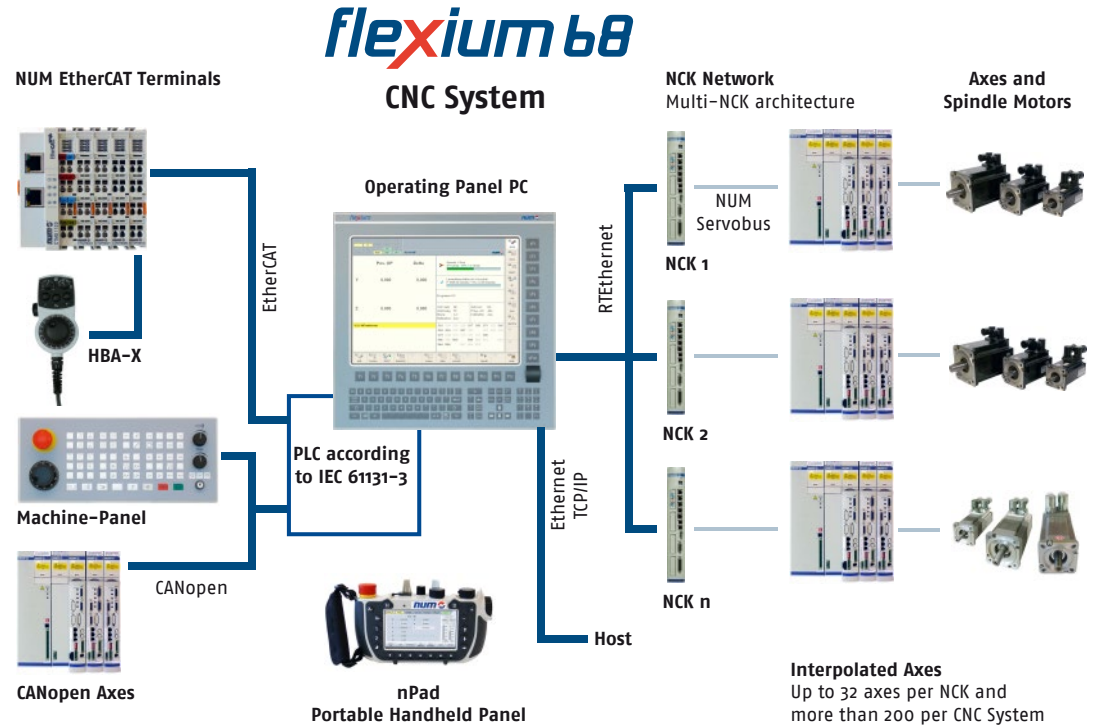

**Note:**

Flexium systems can be configured with more than one operating panel (FS152i series) and more than one machine panel MP04.

# Flexium CNC System Software

---

## Functional Specifications

### System Integration and Customization Flexium Suite

---

#### Fully Open Products for the OEM

NUM CNCs are fully open to the integrator, allowing optimal expression of his know-how and adaptation to a wide variety of machines.

In addition, since the systems are modular, it is easy to add hardware and software options.

The following features characterize this openness:

##### **For the Human Machine Interface**

- Developed in HTML, C++ and MFC, Flexium HMI is easy to customize using off-the-shelf tools
- Organized in contexts, this interface is intuitive and suitable for users on different levels
- It supports the Flexium Tools

##### **For Cycles and Interpolations**

- The dynamic operators provide a tool for developing real-time CNC applications for the axes, inputs/outputs, etc.
- The macros, especially for the cycles called by G functions in the part program, allow the user to edit the basic cycles or create new ones
- Structured programming makes the cycles easier to read and edit

##### **For System Integration**

- Flexium Tools include all necessary utilities for the system integration

#### Flexium Suite

Flexium Suite includes **Flexium Tools** (integration and customisation), **Flexium HMI** (operation) and **Flexium 3D** (Online/Offline simulation) which are described on the following pages.

##### **Flexium Suite on CD**

P/N **FXSW 282 189**

This software package on CD-ROM includes:

- Flexium Suite (Installation)
- Documentation

# Flexium CNC System Software

## Functional Specifications

### System Integration and Customization Flexium Tools

#### Flexium Tools

Flexium Tools is part of the Flexium Suite and includes all functions needed for the integration and commissioning of the machines. Flexium Tools allow to program, configure and optimise all system's components within a unique environment:

- PLC
- Flexium NCKs (CNC)
- Servo drives and motors
- Sensors
- EtherCAT and CANopen gateways with a comprehensive set of I/O and logic terminals

#### Easy operation

The menu structure of Flexium Tools provides a perfect overview of the entire system. Navigation inside the device tree is simple and clear, allowing easy access to all functions for quick change of settings.

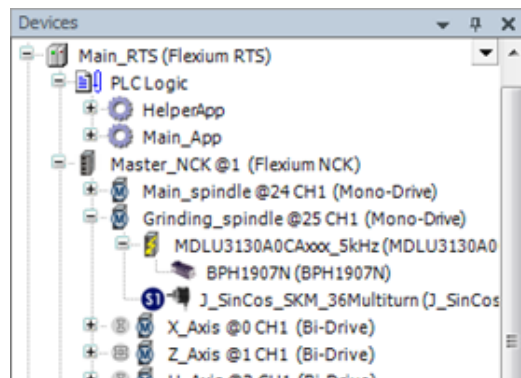

#### Project handling

Access rights can be defined for different users. Each project consists of one single file to ensure easy handling and to prevent data losses. New equipment or versions are quickly integrated using EDS for CANopen devices and Device Descriptions (DevDesc) for NUM devices. Libraries can be used in different versions and can be compiled to protect know-how. Complete projects, including libraries, devices and the source code can be archived, thus making restoration possible at any time in the future.

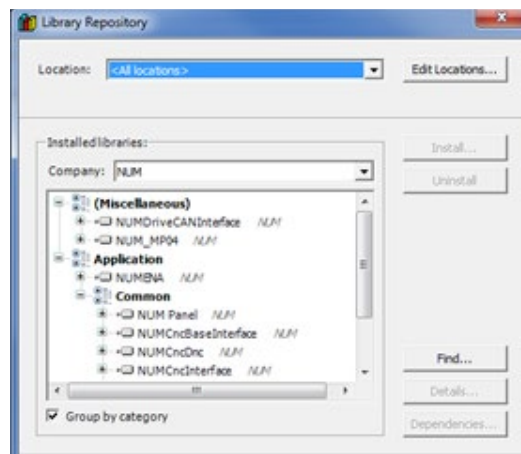

#### PLC System programming

The PLC of the Flexium system is programmed in accordance with IEC 61131-3 and allowed different graphical supported programming environments. For more details see next pages.

#### Flexium NCK (CNC) parameterising

Dedicated editors for options, programming, memory, channels, axes (with individual windows for settings, coupling, kinematics, travels, servo system, HSC) miscellaneous hand wheels, axes calibration and more ensure easy handling and the best overview during editing.



#### Servo drives parameterising

All servo drives of the Flexium System can be found and accessed easily in the menu structure of Flexium Tools. For better overview, the structure is displayed in the way the system is set up, e.g. servo drives are listed under the controlling Flexium NCK.

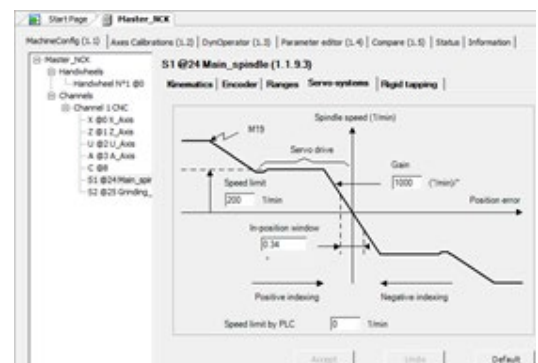
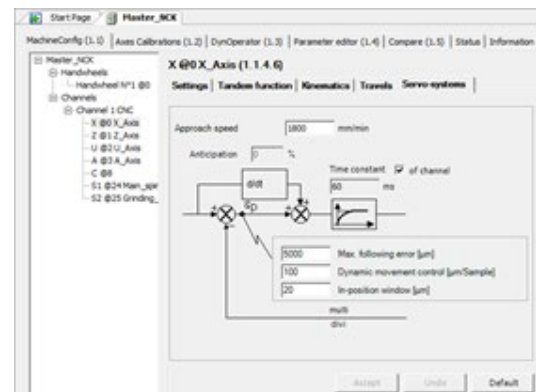

# Flexium CNC System Software

## Functional Specifications

### System Integration and Customization Flexium Tools

#### Field busses

Theoretically, any CANopen and/or EtherCAT compatible device can be connected to the bus using the EDS/ESI/XML file supplied with the device. NUM provides a comprehensive range of most common I/O components based on EtherCAT technology (EtherCAT = Ethernet for Control Automation Technology). It is the real-time Ethernet technology standardized by EtherCAT Technology Group.



NUM provides machine panels (like MP04), drives for auxiliary axes and other devices that, by means of dedicated windows and libraries, can be easily integrated as field bus devices (CANopen)

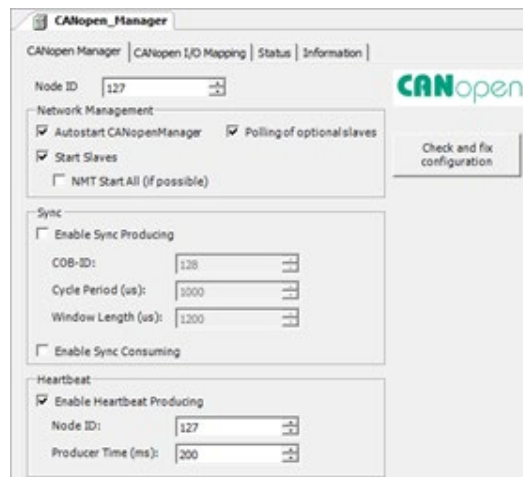

#### Instruments

For easy commissioning, a huge set of instruments is available: Frequency analyser, Ball bar, Contour accuracy Oscilloscope and others.

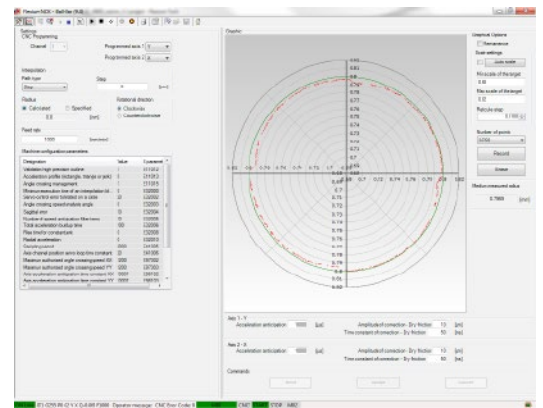
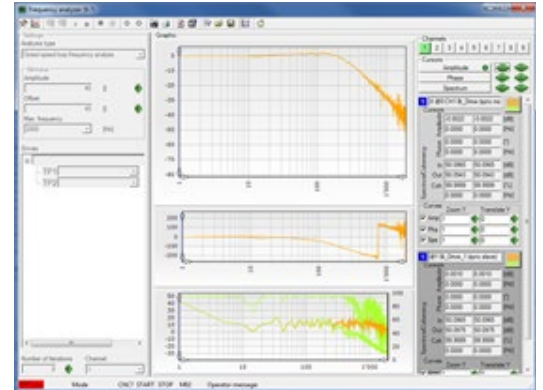

#### Ball-Bar Function

The ball-bar function is integrated in Flexium Tools. It checks the behavior of the axes and sets the parameters related to the servo drives.

Thanks to circles drawn by G02/G03 or by small segments (Tabcyls), this function generates a diagram of the radial error on the main axes or other axis pairs, which facilitates adjustment of the following parameters:

- Acceleration anticipation coefficient
- CNC reference filter time constant
- Pitch compensation

#### Ball-bar trace

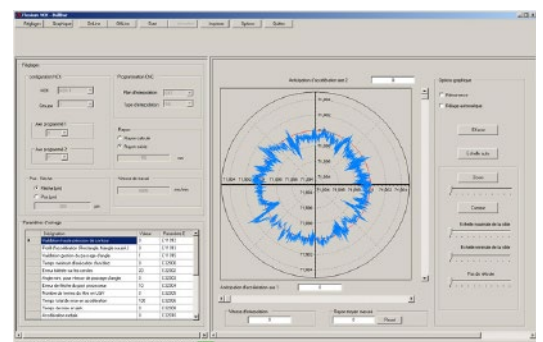



# Flexium CNC System Software

## Functional Specifications

### System Integration and Customization Flexium Tools: PLC Programming

#### PLC Programming

The PLC of the Flexium system is programmed in accordance with IEC 61131-3. Thanks to the five programming languages available in Flexium Tools, existing PLC programs written for NUM Power or Axiom Power CNCs can be easily converted.

The logical and easily manageable development environment offers dedicated tools for development, commissioning and maintenance. The PLC program structure is displayed in a logical structure showing the different blocs and folders. The program editors can be opened in the following languages:

- Instruction List (IL)
- Ladder (LD)
- Function Block Diagram (FBD)
- Structured Text (ST)
- Sequential Function Control (SFC)

The PLC provides libraries for system functions, customer functions and own programming functions.

Task management is very comfortable and can either be cyclic, event-controlled or freewheeling.

Data and variables are based on of a high level language such as Pascal or C. Data types can also be user defined.

The programme can be easily structured using programme building blocks, functions and function blocks with entities.

Object oriented programming is also supported and allows safe programmes using objects, methods, properties, actions, interfaces and inherit functions.

#### PLC in a multi-NCK system

A multi-NCK system for large systems can consist of up to 16 NCKs in connection to one single PLC.

This concept ensures the highest performance and makes configuration as well as operation simple and easy. Even large multi-NCK systems - such as transfer machines - present themselves to the programmer and the operator as one single system.

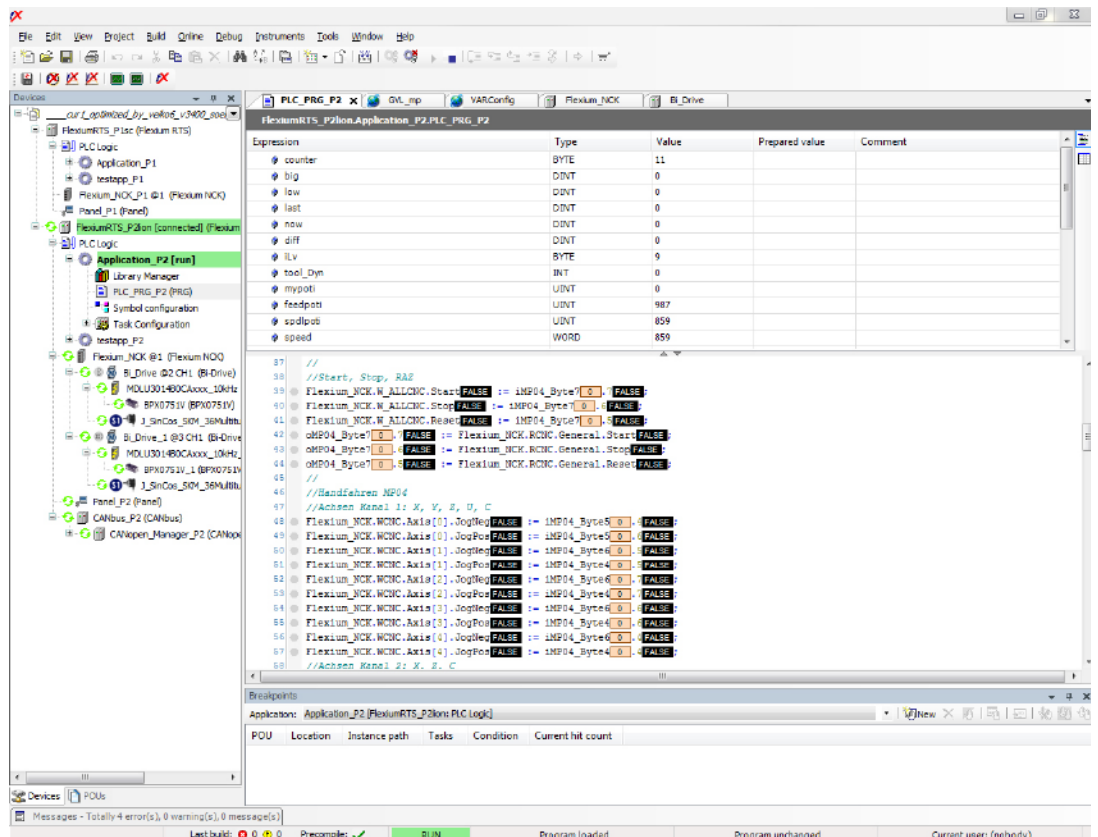



# Flexium CNC System Software

---

## Functional Specifications

### System Integration and Customisation CNC/PLC Exchange Area

---

#### CNC/PLC Exchange Area

Data transfers between the CNC function and the PLC function are carried out using the Exchange Area.

##### **Data Transferred from CNC to PLC**

- Current modes, JOG increments, CNC error number, CNC active, external parameters
- CNC and machine status
- Active programme number
- Axes (initialized, moving, clamped, axis state)
- Spindles (status, speed)

Processing is by channel (from 1 to 8 maximum, depending on the system) for:

- Channel states, G functions, current modes
- Encoded M functions without acknowledgement, on-the-fly
- Encoded M functions with acknowledgement
- 34 decoded M functions
- Tool number

##### **Data Transferred from PLC to CNC**

- Control of axis jogs, mode control, error messages
- Selection of channels, programme numbers
- Processing of spindles, potentiometers, commands, setpoints
- Inhibiting of certain modes, jog commands, feed rates
- Torque and reference enable for digital axes
- External parameters

Processing is by channel (from 1 to 8 maximum, depending on the system) for:

- Machine functions
- The axis feed-rate override potentiometer for all channels

##### **System requirements for Flexium Tools**

The Flexium Tools software is a part of the Flexium Suite and can be downloaded from the Internet or is delivered on CD. The required licences are also available on Internet. The Internet address, the user name and the password will be supplied on hardware delivery.

Flexium Tools requires at least the following:

PC with:

- Pentium processor with min. 800MHz.  
>300MHz processor is recommended
- min. 1GB RAM
- min. 80 MB free space on the hard disc
- CD-drive or connection to the Internet

Operating system:

- Microsoft Windows XP or above, Windows embedded POSReady
- Microsoft Internet Explorer 6.0 minimum
- Windows 7 Prof.
- Mozilla Firefox

# Flexium CNC System Software

---

## Functional Specifications

### System Integration and Customization

#### Flexium SDK

---

#### Dynamic Operators

---

##### P/N FXSO 000 250

This powerful language opens the real-time kernel of the CNC.

It uses simple operations to perform real-time computations which can act directly on the axis position references and on discrete or analog inputs and outputs.

This tool, which also supports exchanges with the PLC program, offers the possibility of immediate correction according to the environment.

The dynamic operators operate with high priority at the real-time clock frequency of the CNC and do not penalize the functions managed by the CNC software. They are very useful in application programs, especially for operations on the servosystems and other high-speed tasks.

---

#### Dynamic Operators in C

---

##### P/N FXSO 000 249

The C language is used to program applications using dynamic operators.

#### Flexium SDK

---

The Software Development Kit is a specific interface for the development of customized operator software. For an optimal use of the interface, training is offered (see corresponding training plan):

##### SDK for Flexium HMI

- How to extend the HMI using HTML and JavaScript

##### SDK for communication with the CNC

- How to develop one's own HMI or a Supervisor software using OOP

**The licence key for the installation of the SDK will be handed out during the training courses.**

# Flexium CNC System Software

## Functional Specifications

### Human Machine Interface Flexium HMI

#### Flexium HMI

The modern, application-oriented Human Machine Interface of the Flexium is a continuous further development of previous NUMpass HMI.

The Flexium HMI is designed for use with the operating panels of the FS152i series and features clear and simple operation. The function keys allow direct and quick access to all relevant functions and menus. The menus are structured in contexts, making comprehensive and profound operations simple and logical.

Flexibility is one distinguishing feature of the Flexium HMI. In addition to the standard configuration, the user interface can be freely customised to the requirements of the user and application-using tools such as HTML, Java, Visual Basic, Delphi, C, and C++ etc. This allows to fully exploit the machine's strong points, logically model the applications and, consequently, increase the efficiency of the machining processes.

The Flexium HMI software is a part of the Flexium Suite and can be downloaded from the Internet or is delivered on CD. The required licences are also available on Internet. The Internet address, the user name and the password will be supplied on hardware delivery.

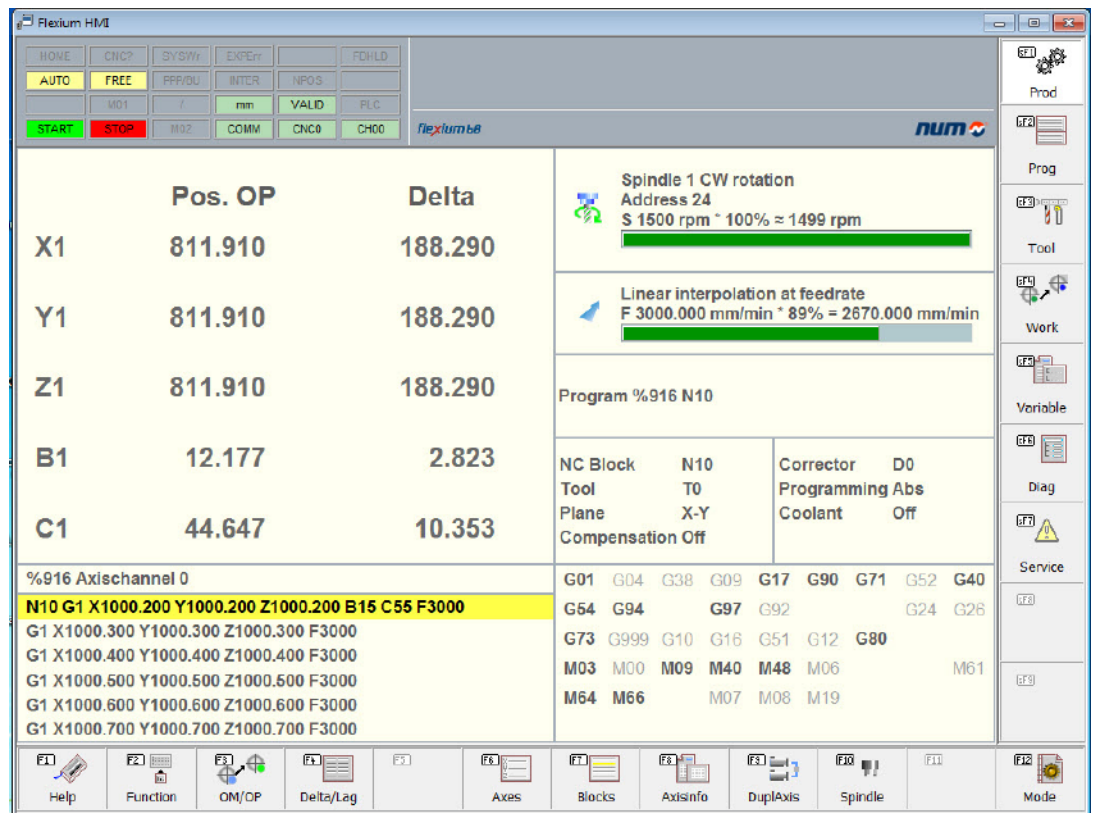

# Flexium CNC System Software

## Functional Specifications

### Human Machine Interface Options

---

#### Symbolic names

##### P/N **FXSW 282 112**

This function allows names to be assigned to the channels. These are displayed instead of the usual address numbers, for example on the axes position page and in the status window.

The channels can be grouped and assigned to a machine.

Part programmes can be assigned to the channels.

Symbolic names can also be assigned to axes and are displayed in the production context.

---

#### Multi-NCK

##### P/N **FXSW 282 117**

The Flexium 68 controls up to 32 axes and/or 8 channels. Multi-NCK extends this limit and allows control over several Flexium NCKs connected to one single PLC e.g. the FS152i. Such systems can include more than 200 axes and are typical for NUMtransfer solutions.

For the operator, the several NCKs present themselves as just one machine, making operation clear and simple. In large systems several operating panels FS152 can be used.

---

#### PLC Visualisation

Flexium offers the possibility to create custom screens controlled directly by the PLC application. This is useful for diagnostic or maintenance purpose as well as supervision.

Four versions are available:

##### PLC Visualisation P/N **FXSW 282160**

- The PLC visualisation can be integrated in Flexium HMI (Production page e.g. for a virtual machine panel) of free pages SF8 and SF9

##### WEB Visualisation P/N **FXSW 282203**

- The PLC visualisation is available on a remote machine via a WEB interface (browser)

##### HMI Classic Visualisation P/N **FXSW 282300**

- The PLC visualisation is displayed on an other PC than the one running the PLC

##### Target Visualisation P/N **FXSW 282302**

- The PLC visualisation is available on the PC running the HMI (outside Flexium HMI)

---

#### Extended tool table

##### P/N **FXSW 282 113**

This feature enhances the tool table in the tool context and allows the addition of:

- a name,
- a comment,
- a channel

to any tool. This information is saved together with the tool data in one single file.

---

#### Teach-in

##### P/N **FXSW 282 114**

This option adds a teach-in function to the editor in the programming context (sF2). The actual axes positions can be transferred easily into an open part-program.

The following settings are possible:

- Selection of the axes
- Extension of the axes positions with CNC functions (G, M, F etc.)
- Insert a block or overwrite an existing block
- Overwrite only the axes positions of an existing block

---

#### Flexium 3D

##### P/N **FXHE 557 200** Flexium3D Dongle

##### P/N **FXSW 282 150** Simulation for Turning T

##### P/N **FXSW 282 151** Simulation for Milling M

##### P/N **FXSW 282 152** Simulation mixed T & M

##### P/N **FXSW 282 153** Simulation with material removal

##### P/N **FXSW 282 154** Simulation with collision detection

##### P/N **FXSW 282 155** Online simulation

Flexium3D is a graphical simulation package for part ISO programs (DIN 66025) with NUM extension. It exists in different configuration for milling turning as well as waterjet, plasma a.s.o.

Several versions are available:

Office version: Used as a standalone program used in production planning without CNC (Dongle is needed).

Machine Version: Integrated in the Flexium HMI for pre-simulation or in online synchronisation to the machining.

The wired path simulation is standard and according to the type of machine (T or M), optionally mixed configurations, material removal as well as collision checking are available.

# Flexium CNC System Software

---

## Functional Specifications

### Human Machine Interface

#### Options

#### System Requirements

---

#### Extended NCK access

---

##### **P/N FXSW 282 124**

This option gives access to a set of requests used for data transfers between the PLC and CNC functions. It allows the transferral of data (bits and words) which is not part of the standard exchange area. These data concern axes, spindles, tools, parameters, part programs, messages, etc.

The transfers are made by requests (read/write). Generally, the PLC is the client and the CNC is the server. The part program can also initiate a transfer to the PLC.

These transfers form the basis for the integration of a machine into a flexible automation system.

---

#### System requirements for the Flexium HMI

---

The Flexium HMI software can be downloaded from the Internet or can be delivered on CD. The required licences are also available via the Internet. The Internet address, user name and password will be supplied on delivery of the hardware.

Flexium HMI requires at least the following:

PC with:

- Pentium processor with min. 800MHz. For several options a higher clock-rate is necessary.
- min. 1GB RAM
- min. 80 MB free space on the hard disk
- CD-drive or connection to the Internet

Operating system:

- Microsoft Windows XP
- Microsoft Internet Explorer 6.0 or higher (IE 9.x not supported)
- Windows 7 Prof.

# Flexium CNC System Software

## Functional Specifications

### Servosystem Flexium CNC System High-Level Functions

#### Flexium CNC System

The Flexium CNC system was developed with modern, tried-and-tested technologies to accomplish the most challenging tasks.

Flexium comes with DISC NT digital servocontrols and high-tech CNC functions, offering exceptional performance capabilities to improve machine productivity.

#### Closed-Loop Servosystem

The main function of a CNC is to continuously control the speed of movement and the position of the moving machine parts.

Each axis of movement is therefore controlled by a closed-loop servosystem or feedback system. The principle of such a system is to continually measure the real position of the moving assembly and compare it with the setting (or setpoint) output by the CNC in order to reach the new programmed position.

#### DISC NT Digital Servobus

DISC NT servobus is based on a high-speed digital bus which manages transfers between the CNC and the axis and spindle servo drives.

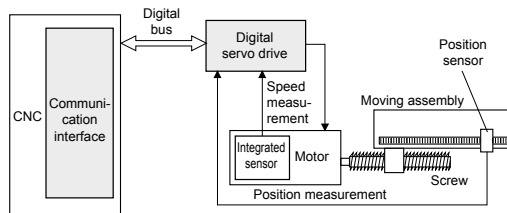

This distributed architecture ensures very fast positioning and excellent servosystem stiffness, thereby optimising contour-following and surface finish.

In addition, such an architecture saves an enormous amount of time on wiring and installation.

#### High-Level Functions

##### Progressive Acceleration

This function provides separate control of accelerations at the work rate and the traverse rate. It uses the gradual acceleration with controlled jerk-rate derivative which is easier on the mechanical assembly of high-speed machines. It is essential on high-speed machining centres.

##### Look-Ahead Function

The «Look-Ahead» function enables the NC to make a predictive analysis of the programmed path across several single machining blocks in advance. Thus, it has the opportunity to recognize problematic path characteristics and react accordingly. For optimal functioning of Look-Ahead, Flexium CNC prepares up to a maximum of 1000 blocks per channel to schedule the programmed feed-rate even when there are many very small NC segments.

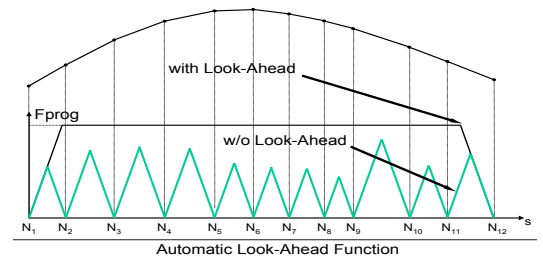

##### Anti-Pitch Correction

When movement on an axis is reversed, speed compensation prevents spikes at quadrant changes.

##### Tandem Function

This function includes two algorithms that are very useful for interdependent motors: backlash compensation and torque synchronization.

# Flexium CNC System Software

## Functional Specifications

### Servosystem

NUMcoss - an additional component of High Speed Cutting (HSC)

### NUMcoss - an additional component of High Speed Cutting (HSC)

NUMcoss is an additional component of High Speed Cutting (HSC) functionality in NUM CNCs (Flexium). It is integrated into Flexium HMI Panel software.

#### Technical background and targets

With NUMcoss, the customer will get an excellent tool to speed up program execution for milling applications in NUM CNCs. Prior to data transfer to NC-kernel, NUMcoss analyses, smoothes and converts path conditions in ISO-programs (generated from CAM systems with integrated post processors) into polynomial data. Thus this conversion happens on Flexium HMI (PC-side) NC-kernel is not stressed and whole kernel performance is free for quick interpolation and the ramp algorithm.

Main criteria in the geometric transformation of NUMcoss are modification tolerance and chord error for linear and rotary axes. That means in which dimension the given linear data (polygon path) can be modified during transition to polynomial data. Addition criteria are specific treatment of different segment lengths as well as correct filtration of spikes and geometric gaps.

#### Smoothing configuration

NUMcoss provides a standard set of smoothing configuration parameters for the machine or application. These parameters can be changed in the ISO-program with specific commands. In addition to this, the user can define sets of smoothing parameters depending on the type of machining (rough, finish and fine finish).

NUMcoss is an optional functionality for high speed application. It can be used for analysing and smoothing ISO-files either in drip feed mode (PPP) or for any other standard ISO-File execution. In this case, Flexium HMI provides an additional file attribute: 'smoothing'.

#### User benefits

With NUMcoss user benefits are improved part quality (enhanced performance, less machine noise, reduced number of facets on work piece). Higher execution velocity (less data transfer PC → CNC, fast polynomial interpolation guaranteed smoother axis movements) and higher accuracy (pre-defined error given from CAM data generation) will be achieved.

### Classic scheme of CAD - CAM - PP - CNC chain

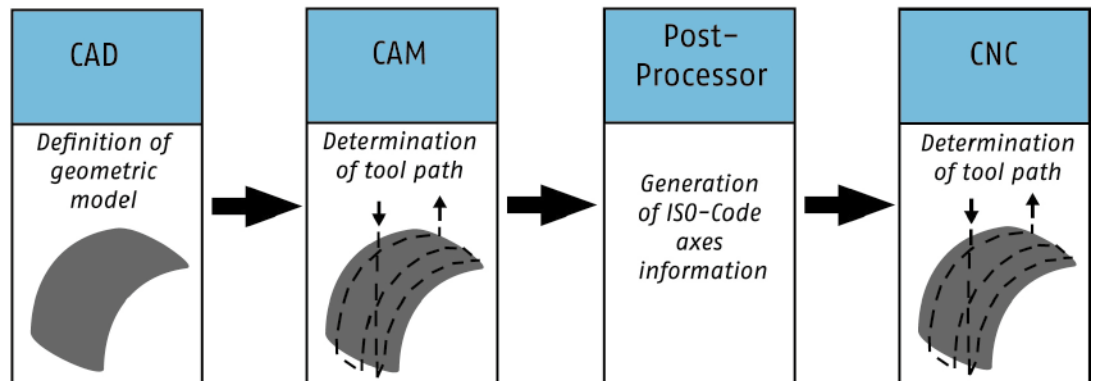

### Integration of NUMcoss in classic CAD - CNC chain

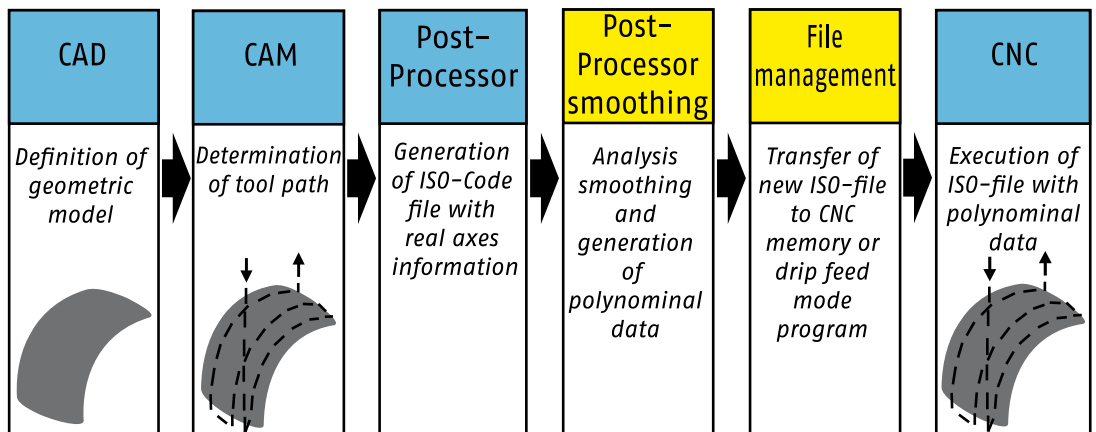

# Flexium CNC System Software

## Functional Specifications

### Axes

#### CNC, Linear, Rotary Axes, Positioning, and Interpolated Axes

##### CNC Axes

Flexium 68

- P/N **FXSO 100 006**: 6th digital axis extension
- P/N **FXSO 100 008**: 7th and 8th digital axis extension
- P/N **FXSO 100 012**: 9th to 12th digital axis extension
- P/N **FXSO 100 016**: 13th to 16th digital axis ext.
- P/N **FXSO 100 032**: 17th to 32nd digital axis ext.
- P/N **FXSO 100 373/374**: Analog interface 1 and 2 for axis, spindle or measurement input

These axes are directly controlled by the CNC software using a program loaded into the user memory area, or in drip feed mode for large programs (developed by CAD/CAM).

Movements are generated in an X, Y, Z cartesian coordinate system which may be supplemented by additional U, V, W axes. These axes may be independent or grouped in carrier/carried axis pairs.

Three rotary axes modulo 360 degrees, A, B and C, are associated with the main linear axes.

##### Linear and Rotary Axes

Closed-loop axis servocontrol ensures:

- Positioning or movement along path of the axes, at a programmed feed rate, with override from 0 to 120%
- Control of acceleration and deceleration, with the possibility of using progressive as well as Jerk controlled acceleration function for smoother mechanical operation on high-speed machines
- Anti-backlash control when reversing movement
- Control of incremental encoder signals for analog axes: semi-absolute measurement which requires homing after power up for analog axes. For digital axes refer to the NUM servodrives chapter

Linear axes are programmable for a travel of +/- 100 meters at a micrometer resolution whilst rotary axes are programmable at the 1/1000° for about 15 revolutions (unlimited number of revolutions for modulo axes). Different resolutions are possible from 1/100 of the standard to 100 times the standard.

##### Positioning Axes and Interpolated Axes

###### Positioning

During positioning, the programmed point is reached via a simultaneous move of all axes involved. The most solicited axis running at its max possible speed. Only the accuracy of the end point is considered.

###### Interpolation

During interpolation, the programmed point is reached by a linear or a clockwise or counterclockwise circular path at the programmed feed rate.

The accuracy of the contour between the start and end points is ensured.

##### Interpolation on 5 to 9 axes

Flexium 68

- P/N **FXSO 100 335**: 5th interpolable axis extension
- P/N **FXSO 100 336**: 6th interpolable axis extension
- P/N **FXSO 100 337**: 7th interpolable axis extension
- P/N **FXSO 100 338**: 8th interpolable axis extension
- P/N **FXSO 100 339**: 9th interpolable axis extension

During interpolation, the programmed axes start, move and stop together.

Being able to interpolate only the number of axes necessary is another example of Flexium's configuration flexibility.



# Flexium CNC System Software

## Functional Specifications

### Axes

Interpolation: Linear, Circular, Smooth Polynomial, Spline, NURBS

#### Linear and Circular Interpolation, Circular Interpolation Defined by Three Points

##### Linear Interpolation at the Traverse Rate (G00)

The programmed point is reached by a linear path at the fastest rate possible.

##### Linear and Circular Interpolation at Feed Rate (G01, G02, G03)

The programmed point is reached by a linear or circular path at the programmed feed rate (clockwise or counter-clockwise path defined by the centre or radius). The path is the result of all the axis movements programmed in the block.

##### Circular Interpolation Defined by Three Points (G23)

P/N **FXSO 000 497**: Circular interpolation defined by three points

Circular interpolation can be executed by programming:

- the start point (defined in the block preceding function G23)
- the end point and the intermediate point (defined in the block including function G23).

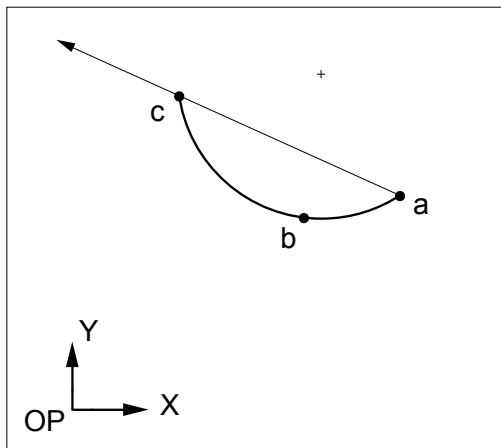

#### Smooth Polynomial Interpolation

P/N **FXSO 000 499**

Smooth polynomial interpolation allows creation of tool centre paths defined by polynomials of degree 5 or less.

These paths are perfectly smooth continuous curves without segments. All the calculated points are located strictly on the curve.

This type of interpolation cannot be used on modulo axes. It is incompatible with tool offsets and backtrack along the path.

#### Spline Interpolation (G06, G48, G49)

P/N **FXSO 000 518**

Spline interpolation is a mathematical method for smoothing curves. Spline curves are apparently continuous curves obtained by linking a series of points.

With spline interpolation, the tangent is continuous and the acceleration is constant in each of the points specified on the programmed paths.

Machining of a spline curve is programmed by defining:

- the points on the curve
- the sequence of execution of the curve.

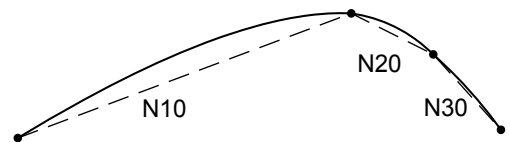

#### Spline Interpolation with 3D Curve Smoothing (G104)

P/N **FXSO 181 706**

Based on polynomial interpolation, this function allows the programmer to define curves of any shape in three dimensions, merely by defining the intermediate points.

#### NURBS Interpolation

P/N **FXSO 000 426**

Geometric continuity of contours is a necessity for HSC.

NURBS (Non Uniform Rational B-Spline) curves, widely used in CAD and now on CNCs, are curves with poles that describe a contour in rational parametric form in order to be able to cut complex shapes with a minimum of contour error.

# Flexium CNC System Software

## Functional Specifications

### Axes

#### Inclined, Tilt, Duplicated, and Synchronized Axes

#### Multichannel Functions, Calibration, Compensations

### Inclined Axes

P/N **FXSO 000 315**

On a lathe or a grinding machine, the X and Z axes can be orthogonal or inclined. The axis inclination or tilt is the angle A between the X axis and the normal to the Z axis. Coordinate conversion takes place downstream of the interpolator.

In an multichannel system, different axis inclinations can be specified for each channel.

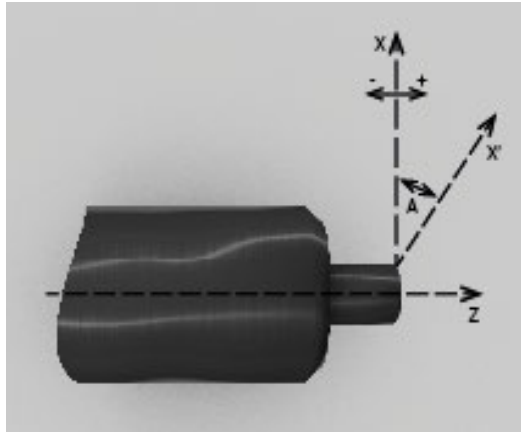

X : main axis in cartesian coordinate system  
X' : inclined physical axis  
Z : main axis  
A : angle of inclination

### Duplicated and Synchronized Axis

P/N **FXSO 000 266**

This function couples one or more slave axes with a master axis, either by setting machine parameters (fixed coupling) or by programming external parameters.

It also ensures synchronization of the master axis with the slave axis (it does not include axis control).

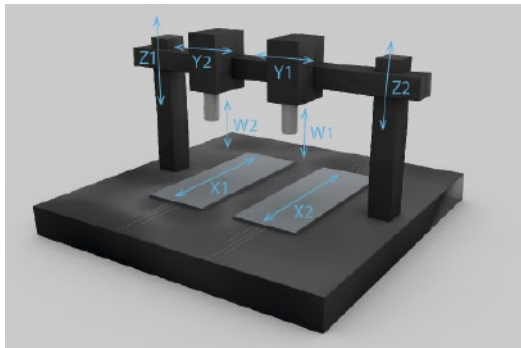

The figure above shows a mechanical gantry axis pair (Z1 and Z2) and a programmable gantry axis pair (X1 and X2).

### Multichannel Function

In the basic version, the Flexium controls a single channel.

Flexium 68:

- P/N **FXSO 100 392**: 2nd channel extension
- P/N **FXSO 100 392**: 3rd and 4th channel extension
- P/N **FXSO 100 393**: 5th and 6th channel extension
- P/N **FXSO 100 394**: 7th and 8th channel extension

All the CNC axes and spindles of a machine can be declared in several channels by setting parameters during installation.

The machining program consists of independent programs (one per channel) denoted by a common radical followed by the channel number.

A spindle declared in a channel can be controlled by that channel or be released and controlled independently.

The multichannel function can be likened to several separate CNCs.

In the multichannel function, the CYCLE START, CYCLE STOP and RESET commands as well as the operating modes are independent for each channel.

In a multichannel configuration, the additional channels can be:

**NC channels:** with all functions of the first channel.

**Auxiliary channels:** they execute a particular part program %9998.i under control of the PLC ( e.g. Tool changer, pallet changer etc...).

The NC channels can run in:

**Common mode:** all channels simultaneously in the same mode.

**Independant mode:** when in execution the different channels can execute different part programs in different mode (homing is always in common mode).

### Axis Calibration and Interaxis Calibration

#### Axis Calibration Function

This function corrects the axis position according to the defects of the screw, rack or scale.

#### Interaxis Calibration Function

This function corrects the position reference of an axis via the position of another axis. The data are entered in a table.

A typical use of this function is to compensate for the weight of the "ram head" on a milling machine.

### Compensations

#### Backlash Compensation

Positioning errors due to mechanical backlash on the linear and rotary axes are corrected automatically.

#### Temperature Compensation

It is possible to correct the axes using the dynamic operators (P/N **FXSO 000 250**) or axis calibration.

# Flexium CNC System Software

---

## Functional Specifications

### Axes

#### Programmable Precision, Inch/Meter Units

---

##### Programmable Precision Measurement Resolution

---

###### P/N FXSO 000 519

The resolution or precision is the value assigned to the measurement unit (increment) generated by the system according to the mechanical assembly of the machine.

The default internal system resolution, common to all the linear axes, is set to 1 micrometer.

The internal system resolution for rotary axes is 0.0001 degree.

These values can be adjusted according to the required accuracy and speeds.

##### Inch/Metric Units (G70, G71)

---

Function G70 is used for programming in inches and G71 in metric units.

The default measurement unit is selected when integrating the system by setting a machine parameter.

# Flexium CNC System Software

---

## Functional Specifications

### Spindle

Automatic Spindle Speed Range Search, Indexing, Synchronization  
Rigid Tapping, Constant Surface Speed, Thread Cutting

---

#### Automatic Spindle Speed Range Search

---

The system determines which one of up to six possible spindle speed ranges corresponds to the programmed spindle speed S. The CNC sends function M40 to M45 to the PLC (via the exchange area), depending on the speed range search criteria set at initialization.

---

#### Indexing (M19)

---

Indexing accurately stops the spindle with a resolution at least of  $1/10^\circ$  or better according to the spindle sensor. The minimum required sensor accuracy is 1024 points per revolution.

---

#### Spindle Synchronization

---

P/N **FXSO 000 156**

This function controls speed synchronization of two measured spindles.

It is used in particular for machining operations such as parting off.

---

#### Rigid Tapping (G84)

---

P/N **FXSO 000 332**

The feed rate on the spindle axis is synchronised to spindle rotation. At the end of tapping, reversal is gradual and smooth.

This function avoids the need of a tool holder with axial float.

#### Constant Surface Speed

---

This basic function of turning products varies the speed of rotation of the spindle according to the position of the tool centre with respect to the diameter of the part.

---

#### Thread Cutting (G33, G38, G31)

---

##### Constant Pitch Thread-Cutting Cycle (G33, G38)

P/N **FXSO 000 331**

This function (basic on turning systems) cuts cylindrical, tapered or scroll threads by synchronising the spindle rotation (workpiece) to the longitudinal axis infeed.

The threads can be single or multiple pitch, executed by straight or angular penetration. The successive passes are carried out with reducing depths.

##### Thread Chasing Cycle (G31)

P/N **FXSO 000 695**

Designed for milling machines, this cycle slaves the feed rate of the tool axis to spindle rotation.

# Flexium CNC System Software

## Functional Specifications

### Spindle

#### C Axis and Coordinate System Conversions, Axis/Spindle Synchronisation

##### C Axis and Coordinate System Conversions

P/N FXSO 000 340

In this turning configuration, the spindle is used as an interpolated axis with one of the CNC axes (X or Z). A resolution of at least 90,000 points per revolution is required for the measurement sensor. The spindle motor sensor used for the speed loop must be a high-resolution sensor.

##### G20: Programming in X, Z and C polar coordinates

This function is used to program the X and Z linear axes and control a rotary C axis modulo 360 degrees.

Use of G20 and polar coordinates

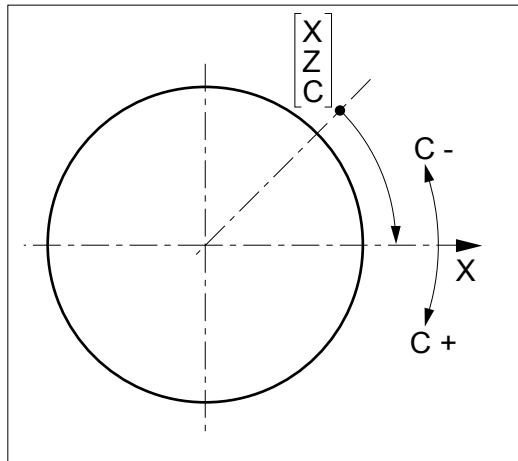

##### G21: Programming in X, Y and Z cartesian coordinates

The system performs cartesian/polar coordinate conversion (conversion of X-Y to X-C). The X and C axes are interpolated for milling in the plane perpendicular to the spindle axis. The tool is driven by an auxiliary spindle.

Use of G21

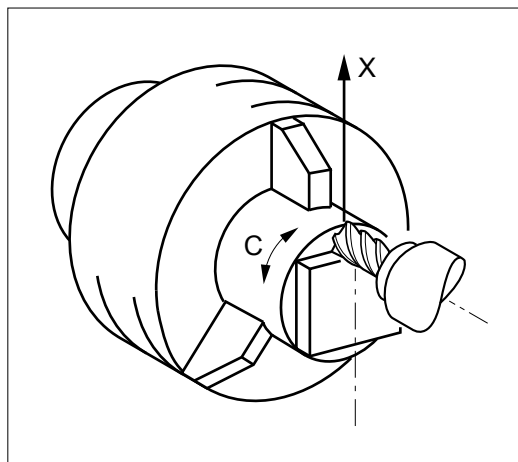

##### G22: Programming in X, Y and Z cylindrical coordinates

The system performs cylindrical/polar coordinate conversion (conversion of X-Y to Z-C). The C axis is interpolated for milling on the involute of the cylinder with radius X. The tool is driven by an auxiliary spindle.

Use of G22

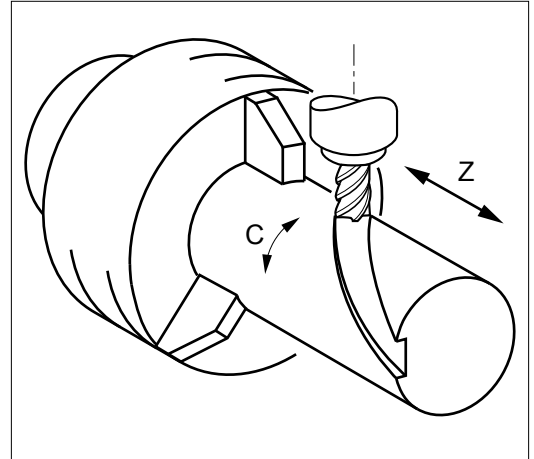

##### Spindle to axis synchronisation

P/N FXSO 000 331

This function slaves the tool displacement to spindle rotation. It is used in particular for thread chasing.

This function also includes constant pitch thread-cutting cycles.

# Flexium CNC System Software

## Functional Specifications

### Tool Management

#### Tool Axis Selection, Tool Wear Offsets, Turning Tool Offsets

### Tool Axis Selection (G16)

#### Milling Tool Axis Orientation

Function G16 with one of the mandatory arguments (P, Q, R) followed by a plus or minus sign defines the tool axis orientation.

The tool axis can be oriented in six different positions on machines with interchangeable toolhead or with bevel gear.

Milling tool axis orientation

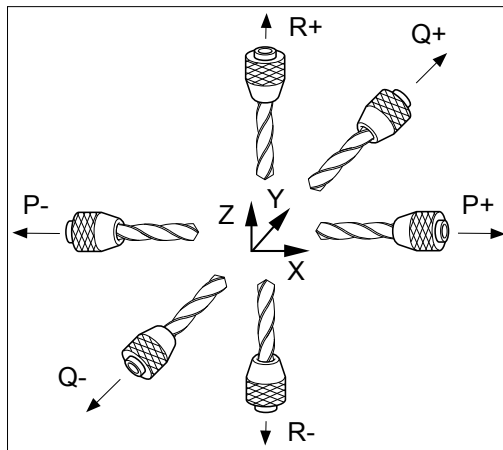

#### Turning Tool Axis Orientation

Function G16 with one of the mandatory arguments (P or R) followed by a plus or minus sign defines the tool axis orientation.

Turning tool axis orientation

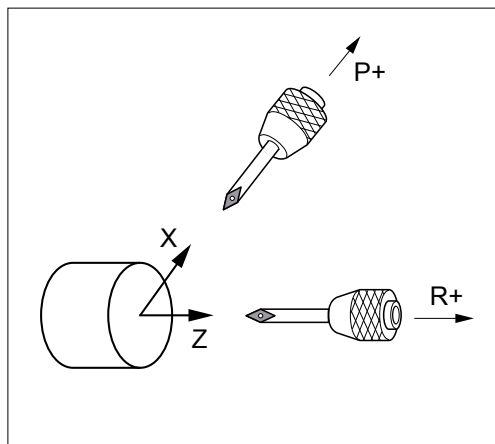

### Tool Wear Offsets

P/N **FXSO 000 401**: Extension to 255 offsets

The basic system includes 32 tool offsets.

The D address followed by a number selects the tool offset.

The tool dimensions are stored in tables and validated according to the programmed axes.

### Turning Tool Offsets

#### Tool Length Offset

The tool length offset is assigned to the tool axis orientation defined by G16.

The programmed tool paths are corrected by a value equal to the tool length X and width Z declared in the D offset selected.

#### Tool Radius Offset

The programmed tool paths are corrected by a value equal to the tool insert radius based on the tool nose orientation defined by codes C0 to C8 declared in the D offset selected.

Tool nose orientation

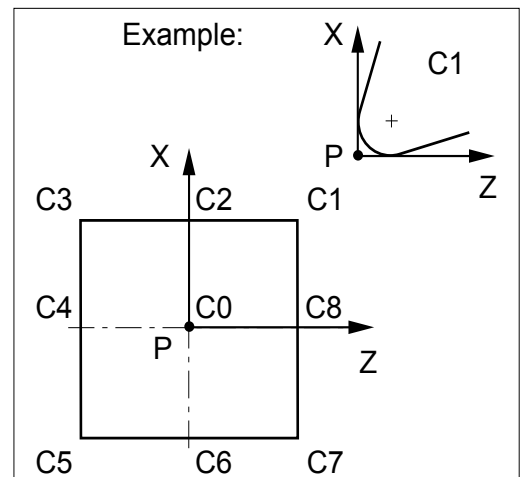

Code C0 to C8 allows the system to identify the location of the centre (C) of the cutting edge of the tool from the theoretical cutting point (P).

Radius of the tool cutting edge

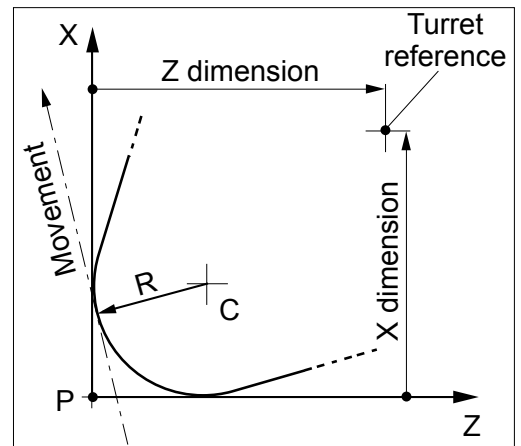

Offset G41 offsets the contour to the left with respect to the direction of movement.

Offset G42 offsets the contour to the right with respect to the direction of movement.

# Flexium CNC System Software

## Functional Specifications

### Tool Management

#### Milling Tool Offsets, 3D Tool Offsets, Dynamic Tool Offsets by the PLC

### Milling Tool Offsets

#### Tool Length Offset

The tool length offset is assigned to the tool axis orientation defined by G16. The programmed tool paths are corrected by a value equal to the tool length L declared in the D offset selected.

#### Tool Radius Offset

The programmed tool paths are corrected by a value equal to the tool radius declared in the D offset selected.

Offset G41 offsets the contour to the left with respect to the direction of movement.

Offset G42 offsets the contour to the right with respect to the direction of movement.

### 3D Tool Offsets

Three- or five-axis 3D tool offsets are used for machining 3D linear paths taking into account the dimensions of the toroidal, spherical (G29) or cylindrical (G43) tool used.

#### 3D Radius Correction for Milling

##### P/N FXSO 000 400

With 3D radius correction, the tool axis is parallel to one of the axes of the basic three-axis reference system defined by the tool axis orientation function (G16). Each programmed point is associated with a vector normal to the surface to be machined, defined by its P, Q and R components.

##### 3D radius correction

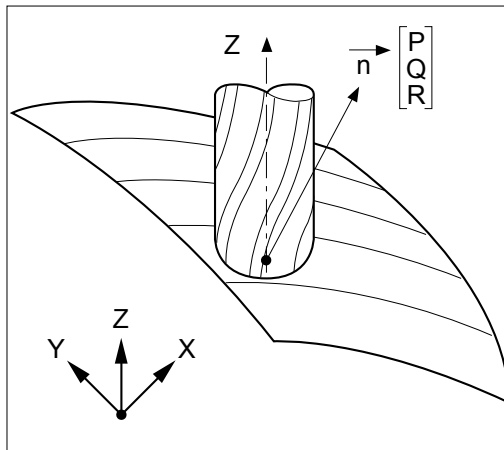

#### 5-Axis Tool Correction

##### P/N FXSO 000 411

With 5-axis tool offset, the tool axis can be inclined on machines equipped with a double twist toolhead.

Each programmed point is associated with a vector normal to the surface to be machined, defined by components P, Q and R, plus a tool orientation vector defined by components I, J and K, where applicable, which define the angles of the twist head.

##### 5 axis tool offset

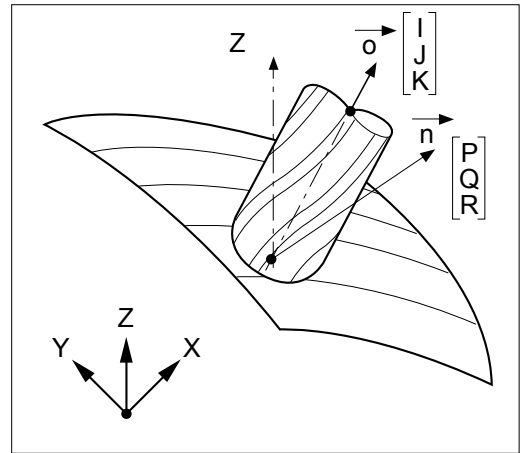

### Dynamic Tool Offsets by the PLC

The operator can enter dynamic offsets at any time (even during machining), whenever he observes a difference between the nominal and real dimensions.

The PLC can also manage dynamic tool offsets associated with external measurement systems to allow the system to automatically apply wear compensation.

These offsets can be positive or negative. They are designed to compensate for slight variations in the tool or workpiece dimensions (wear, expansion).

# Flexium CNC System Software

## Functional Specifications

### Machining Cycles

Milling and Pocket Cycles, 3D Workpiece Position Compensation, Probing Cycles, Inclined Plane Machining

#### Milling and Pocket Cycles

P/N FXSO 000 695

##### Milling Cycles (G31, G81 to G89)

The milling cycles can be called from the main machining program:

- Drilling (center drilling, counterboring, peck drilling, drilling with chip breaking), tapping
- Various types of boring
- Other cycles: thread chasing, etc.

These cycles are provided by ISO subroutines (macros) that can be edited. The standard set can be customized for the type of machine and job for which they are used.

It is also possible to create special cycles. These cycles can then be called from the main program by G functions.

##### Rectangular and Oblong Pocket Cycles (G45)

These cycles facilitate execution of circular, oblong, rectangular and square pocket cycles. The main and secondary axes are programmable in absolute dimensions. They define the pocket center in the plane or the pocket depth, depending on the tool axis.

#### 3D Workpiece Position Compensation (G152, G153, G154)

P/N FXSO 000 915

Setting up a workpiece causes position and orientation differences of the stock with respect to its theoretical mounting.

The 3D WPC performs a re-orientation of the work piece coordinate system and can be used conjointly with the Inclined Plane function and RTCP.

G codes are dedicated for 3D WPC:

G152 :	'3D Workpiece Position Compensation' ON + optional Tilted Plane
G153 :	'3D Workpiece Position Compensation' ON + optional RTCP
G154 :	Re-positioning of the machine-head

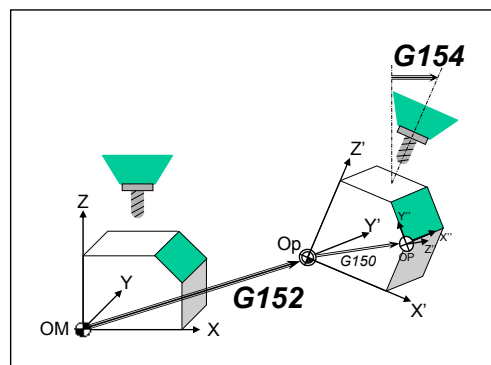

3D Workpiece Position Compensation

#### Inclined Plane Machining (G150)

P/N FXSO 000 914

The inclined-plane machining function manages many different machine head structures and simplifies programming of the machining operations.

Rotation and translation are combined to define a three-axis reference system with any orientation, used by the CNC to control the machine.

All the functions are preserved: L and R tool offsets, canned cycles as well as control of speed and feed, acceleration and travel.

The inclined reference system is defined as follows:

- UVW / XYZ translations
- ABC rotations around each of the XYZ axes

All five-axis machine structures are supported with their offsets:

- Machine-head with two rotary axes with or without angle
- Machine-head with one rotary axis and turntable with one rotary axis
- Turntable with two rotary axes

The inclined plane machining function is customized using Flexium tools.

The installation program generates a macroprogram which contains the description of the machine kinematic.

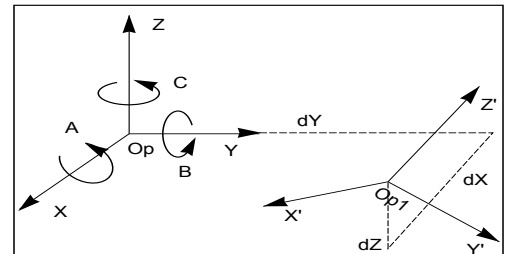

Specify rotation A B C  
Specify translation on dX dY dZ  
OP1 new workpiece origin



# Flexium CNC System Software

## Functional Specifications

### Machining Cycles

Milling and Pocket Cycles, 3D Workpiece Position Compensation, Probing Cycles, Inclined Plane Machining

#### Tilted nozzle management

P/N FXSO 000 404

This feature is mostly used for jet cutting applications. It is intended to take into account the fact that the cutting head is not always perpendicular to the interpolation plane by recalculating the angles and continuously repositioning the nozzle to keep the same inclination.

The nozzle orientation vector, that will in fine reposition the head, is defined by two curves figuring the jet center path at the top of the part and at the bottom of it.

- At the top, the trajectory is created from the program trajectory like for the usual G41/G42 compensation
- At the bottom the trajectory is offset by the value of the jet radius + the tilting effect (nozzle angle along the part height). Depending on the type of crossing it may add an additional connecting block between two programmed blocks. It also performs the anti-collision monitoring at top and at bottom
- Due to the orientation the jet section is no more a circle but an ellipse. The system will automatically adjust the value to compensate correctly

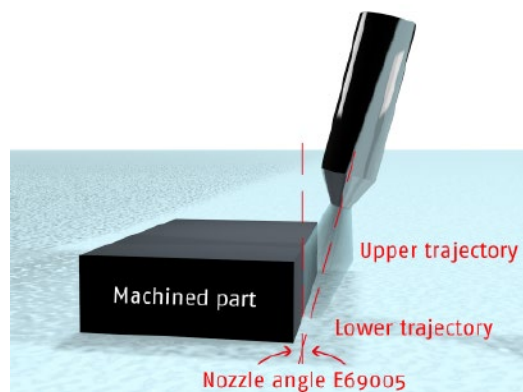
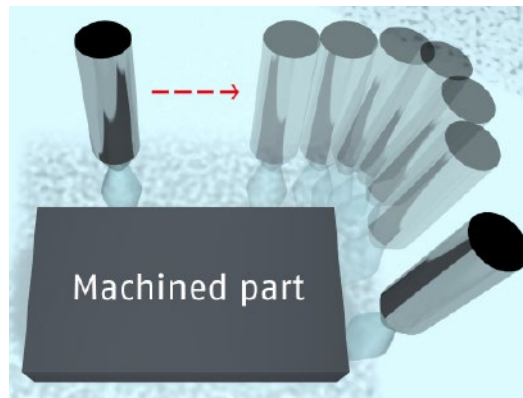

Example of the principle.

#### Probing Cycles for Milling Machines

P/N FXSO 100 591

These cycles are designed for use in setting and measurement applications generated manually or automatically. They include the following functions:

- Probe calibration
- Tool presetting (L, R)
- Determination and restoring of DAT2 on the X, Y and Z axes (workpiece location) and DAT2 on the A, B and C rotary axes (workpiece alignment on a table)
- Determination and restoring of DAT3 (off-centering of a workpiece on a table)

These cycles can be edited.

# Flexium CNC System Software

## Functional Specifications

### Machining Cycles

RTCP, Auto n/m Function, HS Precision Contours, Radial Axis Boring/Milling

#### RTCP Function (G151)

P/N **FXSO 000 154**

This RTCP function (Rotation around Tool Centre Point) can be used with all known five-axis machine structures.

It provides automatic compensation on the main machine axis for the offsets caused by movement of the rotary axes of a five-axis machine. This compensation preserves the position of the center of a ball-end tool during the interpolation.

The RTCP function is customized using Flexium tools.

The installation program generates a macroprogram which contains the description of the machine kinematic.

Since this function does not handle tool orientation, it may be necessary to supplement it with the N/M auto function.

An inclined plane function identical to option **FXSO 000 914** is integrated with this option.

RTCP ON and RTCP OFF.

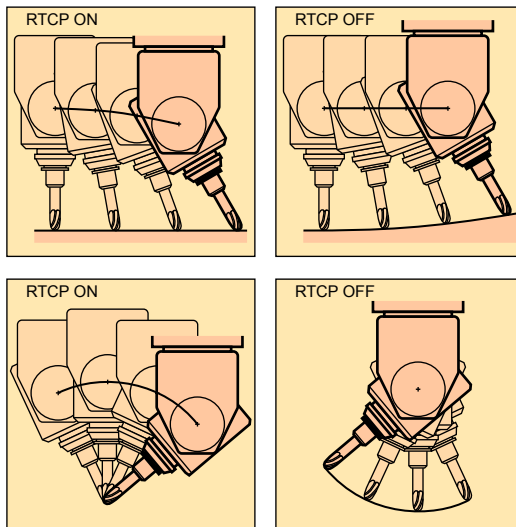

#### Auto n/m Function

P/N **FXSO 000 082**

When enabled by the PLC, this function allows the operator to manually control up to five axes while the other axes remain under control of the part program.

The axes which can be controlled manually are selected and deselected by external parameters in the part program. Any commands in the program for movement on these axes are then ignored.

#### High-Speed Machining of Precision Contours

P/N **FXSO 000 155**

This function practically eliminates the following error, even at high machining speeds. This is achieved by the following mechanisms:

- Total speed anticipation
- Acceleration anticipation
- Anti-pitch correction: when machining circles, the friction torque appears as dynamic backlash when reversing direction; the adjustable correction compensates for this friction torque
- Gradual acceleration with controlled jerk-rate derivative
- Accurate feed control based on upcoming changes in the machining path

This control requires evaluating the curve radius over a sufficiently long section of future path (horizon). It also requires detecting and evaluating the sharpness of corners which may exist on this segment of path. For form machining, up to 60 blocks can be controlled in complicated sections of paths.

#### Radial Axis Boring/Milling Function

P/N **FXSO 000 514**

This function allows interpolation of a radial axis (Z or U) as required for a boring application.

# Flexium CNC System Software

## Functional Specifications

### Machining Cycles

Functions: Combined Machine, Polygon Cutting

Cycles: Turning, Customized, Probing for Lathe

#### Combined Machine Function

P/N FXSO 000 581

This option includes the basic milling functions plus several functions for controlling a combined machine (milling + turning):

- Axis/spindle servocontrol
- Support of a radial axis (boring)
- Cartesian/polar coordinate conversion
- Turning cycles
- Double-windowing graphics

#### Turning Cycles

P/N FXSO 000 696

**Turning Cycles (G63 to G66, G81 to G87, G89)**

These cycles can be called from the main machining program:

- Groove roughing, face-turn roughing, plunging
- Drilling (center drilling, counterboring, peck drilling, drilling with chip breaking), tapping
- Boring cycles

These cycles can be edited and special cycles can be created. They are called by G functions (see Customized Cycles).

#### Creation of Customized Cycles

It is possible to create additional cycles that are specific to an application or a machine. These cycles are then called by new G or M functions. For G functions, it is possible to create programs %10100 to %10255 and call them by functions G100 to G255 respectively. For unassigned M functions, a machine parameter, 'subroutine call by M function' is used to call a program number defined at installation when the M function is detected in the part program.

#### Polygon-Cutting Function

P/N FXSO 100 538

This turning function is used for cutting flats or polygonal shapes on the surfaces of parts of revolution.

The cutting technique is based on synchronization of a rotary axis with a spindle rotating in the same direction with a programmed speed ratio.

Relative tool/workpiece position for polygon cutting

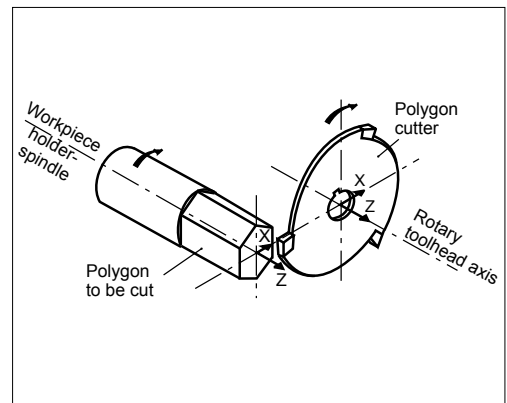

#### Probing Cycles for Lathe

P/N FXSO 100 590

These cycles are designed for use in adjustment and measurement applications generated manually or automatically. They include the following functions:

- Probe calibration
- Tool presetting
- Workpiece measurement and offset adjustment
- Determination and restoring of DAT2 on the linear X and Z axes

All these cycles can be edited.

# Flexium CNC System Software

## Functional Specifications

### Program Interrupts

#### On-the-Fly Measurement Acquisition, Backtrack, Emergency Retraction

##### On-the-Fly Measurement Acquisition (G10)

P/N FXSO 000 520

The application of a signal to one of the two high speed specific inputs causes the target end point dimensions to be replaced by the current point dimensions and stores all axis positions on interrupt into external parameters.

##### Backtrack along Path

P/N FXSO 000 523

This function, available only for channel 1, is used to backtrack the axis, then return it to the point where the program was interrupted.

On a feed stop command, the operator enables the latched (modal) backtrack-along-path command. The axis is moved back along the path at the feed rate programmed in the stored blocks (up to 100). This function is operative in automatic, single-step and dry run modes.

When the operator enables the return command to resume the program to the point where feed was stopped, the initial mode is restored on resuming the block interrupted by the feed stop.

Tool offsets and wear offsets less than 0.1 mm can be applied during backtrack and return.

The program can be resumed ahead of the backtrack point. The automatic axis recall function can be used in intervention mode. In this case, the points on the manual backtrack path are stored (maximum 10 points) and restored in the same order in the axis recall phase at traverse rate, up to a programmable distance from the restart point.

##### Emergency Retraction (G75)

P/N FXSO 000 505

A signal sent to the PLC interrupts the current block and causes a jump to the specified program sequence.

Example:

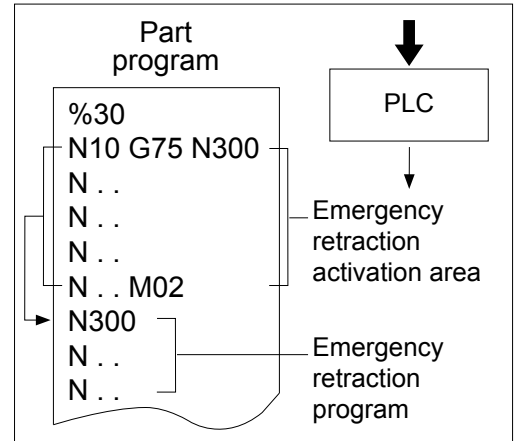

# Flexium CNC System Software

---

## Functional Specifications

### Part Programming

#### Part Program, Resident Macros, Manual Input, Drip Feed Mode

---

##### Part Program and Macros

---

This part of the global memory can be divided into four functional areas:

Area 0: Modifiable user area

Area 1: Protected customer area

Area 2: Protected OEM area

Area 3: Area reserved for NUM

Each program or macro in the protected areas can be protected against display, editing and downloading. This safeguards proprietary information and guarantees the functional integrity of the machine.

---

##### Resident Macros

---

Resident macros are part programs developed by NUM, the OEM or the machine manufacturer, and are loaded into the protected memory areas.

These programs are written in standard ISO language and structured programming to facilitate understanding and modification (examples: customized canned cycles).

##### Editing the macros related to canned cycles

A utility included in Flexium HMI is used to retrieve those cycles for editing purposes. The modified cycles can then be retransferred to any area other than the NUM area where they will get a higher priority.

##### Entering Programs from the Panel

---

###### Manual Data Input (MDI)

MDI is used to execute one command at a time.

The commands entered are not saved in a part program. The last 100 commands can be recalled in MDI at any time.

---

##### Editing Programs

---

Programs can be edited in the mass memory (hard disk) area at any time. Such modifications will be taken into account only after reloading the program in the NC.

It is also possible to edit the programs directly into NC memory in end of block stop. Such editions are taken into account immediately. This is very useful to change a feedrate for example or to correct a syntax error.

---

##### Program Execution in Drip Feed Mode

---

When a program is too long to be loaded into the CNC memory or if it is not desired to store it (e.g. a program developed by a CAD system or subject to further modification), it can be run by direct download from a peripheral or a computer.

Certain restrictions concerning branches, subroutines and emergency retraction blocks apply to programs executed in so-called drip feed mode.

# Flexium CNC System Software

## Functional Specifications

### Part Programming

#### Datum Shifts, Dynamic Software Switches, ISO/EIA Language

### Selecting the Dimensioning System: Datum Shifts

Regardless of the programming mode selected, the system always processes the dimensions with respect to a zero point or origin.

#### Measurement Origin (OM)

The measurement origin is a suitable point defined on each axis which sets the absolute measurement origin or zero point. The coordinates of this point can be entered or modified in special machine parameters.

#### Part Origin (Op)

The part or workpiece origin is independent of the measurement system. It is defined with respect to a suitable setting point on the workpiece. The part origin is specified with respect to the measurement origin by datum shift DAT1.

#### Program Origin (OP)

The program origin defines the origin of the program coordinate system. It is independent of the measurement system and is specified with respect to the part origin by datum shift DAT2.

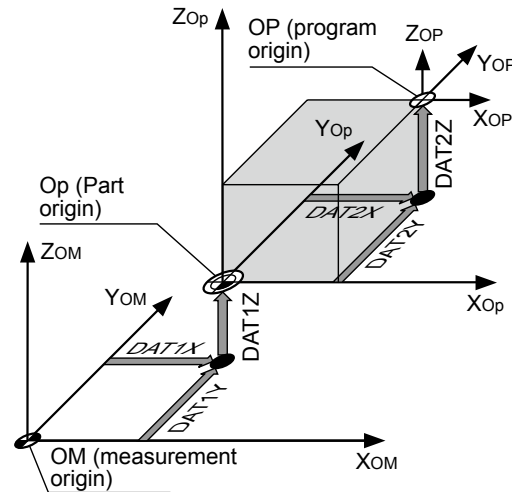

### Dynamic Limit Switches

The machine travels entered when setting up the machine may be dynamically limited by software. This function is useful for modifying the travel according to the workpiece to be machined or its environment (collision avoidance). External parameters are placed at the beginning of the part program for this purpose.

These parameters are applied starting from their location in the program and remain valid until the CNC is reset or until the end of the program.

Dynamic limit switches are active in all modes.

### Main Functions

#### Programming of Movements

- Programming in absolute or incremental dimensions
- Machine or program dimensions
- Floating zero
- Inch/metric units
- Movement by positioning (G00) or interpolation: linear (G01), circular (G02) (G03), helical, spline or polynomial
- Positioning at a distance R from a programmed point
- Programming of lines and circles in cartesian or polar coordinates
- Connection of lines and/or circles by fillets or chamfers
- Block sequencing on paths or possibility of stopping to cancel the following error (G09) in order to pass through specified points

#### Feed Functions

- Feed rate F.. from 0.01 mm/min to 100 m/min
- Special feed rate for fillets and chamfers in PGP programming
- Programmable intervention by M12
- Tangential feed G92 R
- Acceleration override by EG

#### Canned Cycles

Modifiable canned cycles are available. They can be edited as needed. Customized cycles can be written for special machining jobs or machines (see Cycles).

### ISO Language

General format:

%.....	
N.....	Sequence number
G...	Preparatory functions
XYZ+7.1 or 6.2 or 5.3 or 4.4 or 3.5	Axis movements
UVW+7.1 or 6.2 or 5.3 or 4.4 or 3.5	Auxiliary axis movements
ABC+3.3 or 3.4	Rotary axis movements
IJK+5.3	Circle center coordinates
EA3.3	Taper angle
EB5.3	Fillet or chamfer
EC3.3	Indexed spindle axis
ED3.3	Programmed angular offset
R5.3	Circle radius
F....	Feed rate
M...	Miscellaneous functions
S.....	Spindle speed
T.....	Tool number
D....	Tool offset
L....	Program variable
E.....	External parameter
H....	Subroutine number
/	Block skip

# Flexium CNC System Software

## Functional Specifications

### Part Programming

Subroutines, Parametric/Structured Programming, Contour Table

Transfer of Active Settings, Scaling Factor, Programmed Angular Offset

#### Subroutines (G77)

Subroutines are special programs called by the main program. They are created by the OEM, by NUM (case of macros) or by the user to simplify and optimize the main program.

Example: Pattern repetition in several locations.

Subroutines are called by addresses H.. and/or N.. N.. associated with the function.

G77	Unconditional branch to a subroutine or sequence of blocks with return (maximum 8 subroutine nesting levels)
H	Number of a subroutine external to the main program
N..N..	Number of the first and last block called
S..	Number of repetitions of a subroutine or block sequence (maximum 99)

Subroutines can also be called by the PLC or by an M function.

#### Parametric Programming

Parametric programming simplifies the writing of programs and the creation of identical families.

Variables L and external parameters E can be assigned to all the program addresses. Operations available on parameters:

- Addition, subtraction, multiplication, division, square root, truncation, sine, cosine, arc tangent
- Conditional and unconditional branches (>, <, =), logic AND and OR

#### Structured Programming

P/N FXSO 000 535

Structured programming based on symbolic variables makes programs easier to read and understand.

Symbolic variables (1 to 8 characters) can be assigned to all ISO functions and used in parametric expressions.

Variables L are saved and symbolic variables are allocated in a stack located in the bottom of the memory.

#### Construction of a Contour Table (Build Function)

P/N FXSO 000 536

This high-level programming function is used to create a table and to store the data concerning a contour while the corresponding blocks are read (axis dimensions, F, T, S functions).

The data in the table are accessed and used by structured programming.

#### Transfer of Active Settings (G76)

P/N FXSO 000 511

This function is used to update the contents of a file included in a subroutine or a block sequence of the main program.

The file of variables L and parameters E is updated with the corresponding new current settings.

Syntax:

G76      Transfer of the current settings of variables L and parameters E to the program specified  
H      Specifies the program to which the settings are to be transferred  
N..N..      Specifies the block sequence to which the settings are to be transferred  
H%..      (example and format of the file to which the settings are transferred)  
N.. Lxx=..... E8....=  
|  
|  
N.. E5....=

#### Scaling Factor (G74)

P/N FXSO 000 506

The scaling factor can be entered from the keyboard or via an E parameter to modify the dimensions of the part to be machined.

It is expressed in thousandths of the programmed dimensions. The variations are between 0.001 and 9.999.

#### Programmed Angular Offset (ED..)

P/N FXSO 000 507

Function ED is assigned a value which defines an angular rotation with respect to the program origin.

The angular offset affects the axes programmed in the blocks following the function.

Example of application: machining along a circular pattern.

# Flexium CNC System Software

## Functional Specifications

### Part Programming

#### Index Table Eccentricity Function, Profile Geometry Programming

##### Index Table Eccentricity Function

This function applies to the A, B or C rotary axes. The offsets can be applied by entering values:

- On the CNC after switching to SHIFT mode
- By external parameter E
- By processor interchange

For positioning, the index table eccentricity function takes into account a theoretical rotational shift of the part with respect to the table axis of rotation, regardless of its angular position.

Index table eccentricity function

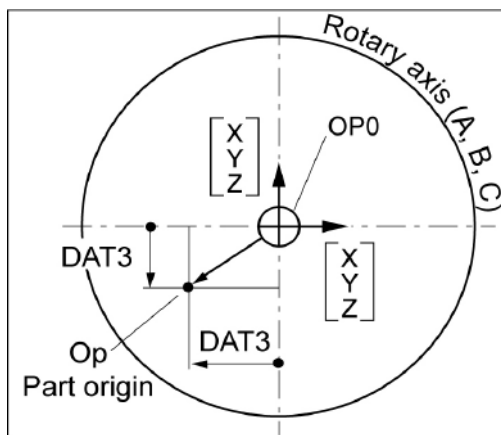

##### Profile Geometry Programming PGP®

This special ISO programming language allows the rapid development of parts with a complex geometry consisting of a sequence of linear and circular geometric elements.

###### Main Functions:

- Insertion of fillets and chamfers
- Multiple line definitions
- Multiple circle definitions
- Possibility of implicitly declaring from one to three consecutive elements and having the system compute the intersection or tangent points





# 5 NUM Motors

NUM Motors BHX, BPX, BPH, BPG, BHL, AMS, IM Spindle Motors, AMR

## Table of Contents

---

	Page
<b>NUM Motors</b>	<b>83</b>
Introduction	83
Applications	83
<b>NUM Motors BHX, BPX, BPH, BPG, BHL</b>	<b>84</b>
General Characteristics	84
Technical Characteristics	85
Technical Characteristics	86
Outline Drawings BHX Motors	89
Outline Drawings BHX Motors	90
Outline Drawings BPH and BPG Motors	91
Outline Drawings BHL Motors	92
Ordering Codes	93
Accessories	96
Accessory Descriptions	99
<b>NUM Motors AMS and IM</b>	<b>100</b>
General Characteristics	100
Technical Characteristics	101
Outline Drawings AMS Motors	102
Outline Drawings IM Motor	104
Ordering Codes	105
Accessories, Accessory Descriptions	106
<b>Auto-Transformer</b>	<b>107</b>
Technical Characteristics, Outline Drawings	107
<b>Special and Built-In Motors</b>	<b>108</b>
General Information	108



# NUM Motors

---

NUM Motors BHX, BPX, BPH, BPG, BHL, AMS, IM Spindle Motors, AMR

NUM Motors  
Introduction  
Applications

---

## Introduction

NUM builds a comprehensive range of motors with a high power-to-weight ratio and dynamic range. The vast variety allows NUM to provide solutions perfectly tailored to each application.

In conjunction with NUM Drive servo drives these motors offer an excellent stability even at very low rotational speeds.

NUM motors are equipped with robust optical encoders of different resolution/accuracy levels to fit the requirements of the machine and the application.

---

## Applications

- BHX servo motors: very compact, optimal moment of inertia; axes of machine tools, grinding machines, robotics and special automatic machines
- BPX servo motors: higher torque than BHX, IP67, optimal moment of inertia; axes of machine tools, grinding machines, robotics and special automatic machines
- BPH servo motors: axes of machine tools, grinding machines, robotics and special automatic machines
- BPG servo motors: as BPH but with increased inertia and rotor stiffness; for axes with high inertia at the motor shaft
- BHL servo motors: as BPH but specifically designed for large machines. A version with forced convection is available for optimizing size and performance
- AMS and IM spindle motors: typically machine tool spindles
- Special and built-in motors: NUM is constantly developing various customized motors:
  - Liquid cooled spindle motors
  - Liquid cooled servo motors
  - Built-in motors (Motorspindle®) both synchronous and asynchronous

For details about these motor types or custom motors please contact our sales offices.

# NUM Motors

NUM Motors BHX, BPX, BPH, BPG, BHL, AMS, IM Spindle Motors, AMR

NUM Motors BHX, BPX, BPH, BPG, BHL  
General Characteristics

## NUM Motors BHX, BPX, BPH, BPG, BHL

The all new BHX / BPX brushless servo motors are designed with neodymium magnets and combine high power with low weight and small dimensions. The BHX motors are characterised by a moment of inertia well adapted to the machine industry. The existing range will be expanded frequently.

BPH, BPG, BPL and BHL brushless servo motors are designed with samarium cobalt magnets ensuring a high power-to-weight ratio, a high dynamic speed range, and a compact size.

### General Characteristics

General Motor Features	As per EN60034-1
Environment Storage Conditions: Temperature Range Relative Humidity	- 20 to + 80 °C max. 80% without condensation
Environment Working Conditions: Temperature Range Altitude	0 to 40 °C without derating, max. 55 °C with derating 0 to 1000 m without derating, max. 3000 m with derating
Continuous Stall Torque Range	From 0.5 Nm up to 160 Nm
Degree of protection as per EN60529	BHX: Housing IP64, shaft IP54 BPX: IP67 (For BPX055 reachable with air pressure barrier) BPH, BPG: IP65 and optionally IP 67 BHL: Housing IP65, shaft and fan IP54
Connection	By rotary connector (excluding BHL)
Permanent Magnet Holding Brake	24 Vdc available as option (excluding BPG)
Motor Transducer	High resolution single turn and multi turn optical encoder Medium resolution single turn and multi turn optical encoder
Mounting Restriction	No mounting restrictions, IMB5 - IMV1 - IMV3 as per EN60034-7
Fan Input Voltage	400 Vac $\pm$ 5% 3 phases, 50/60 Hz (for BHL260 only)

Motor range	Main characteristics	Typical applications	Continuous torque	Frame sizes	Available options
<b>BHX</b>	Very compact, high inertia, IP64	Feeding axes for cost-effective machine tools	From 1.2 Nm up to 20 Nm	75mm, 95mm, 126 mm and 155mm	Holding brake, keyed shaft, medium and high resolution single and multi turn encoder
<b>BPX</b>	Extremely compact, high peak torque, smooth operations, high inertia, IP67	Feeding axes for high-end machine tools, grinding machines, robotics and special machines	From 0.5 Nm up to 23 Nm	55mm, 75mm, 95mm, 126 mm and 155mm	Holding brake, keyed shaft, medium and high resolution single and multi turn encoder
<b>BPH</b>	Compact, smooth operations, medium inertia, up to IP67	Feeding axes for high-end machine tools, grinding machines, robotics and special machines	From 1.3 Nm up to 100 Nm	75mm, 95mm, 115mm, 142mm and 190mm	Holding brake, keyed shaft, medium and high resolution single and multi turn encoder
<b>BPG</b>	Compact, smooth operations, very high inertia, up to IP67	Feeding axes for high end machine tools, grinding machines, robotics and special machines	From 1.3 Nm up to 56 Nm	75mm, 95mm, 115mm, 142mm and 190mm	Keyed shaft, medium and high resolution single and multi turn encoder
<b>BHL</b>	Very compact, high inertia, IP65	Feeding axes for large machine tools	From 85 Nm up to 160 Nm	260mm	Holding brake, keyed shaft, medium and high resolution single and multi turn encoder

# NUM Motors

NUM Motors BHX, BPX, BPH, BPG, BHL, AMS, IM Spindle Motors, AMR

NUM Motors BHX, BPX, BPH, BPG, BHL  
Technical Characteristics

## BHX Motors

For peak torque figures please refer to chapter 7 where the drive-motor associations are described.

	Low speed cont. torque	Rated speed	Rotor Inertia		Motor weight		Brake		Low speed cont. current	Dimensioning Power
			without brake	with brake	without brake	with brake	Torque	Current		
	[Nm]	[rpm]	[g.m <sup>2</sup> ]	[g.m <sup>2</sup> ]	[kg]	[kg]	[Nm]	[A]	[Arms]	[kW]
BHX0751V5...	1.2	6 000	0.07	0.08	2.1	2.3	2.2	0.4	1.7	0.75
BHX0752V5...	2.1	6 000	0.13	0.14	3.1	3.3			3.1	1.32
BHX0951V5...	2.4	6 000	0.20	0.26	3.4	4.1	6	0.7	3.0	1.51
BHX0952N5...	4.3	3 000	0.37	0.43	4.8	5.5			2.8	1.35
BHX0952V5...		6 000							5.6	2.70
BHX1261N5...	4.5	3 000	0.55	0.69	5.5	7	13	0.8	3.2	1.41
BHX1261V5...		6 000							6.4	2.83
BHX1262N5...	8.4	3 000	1.07	1.21	8	9.5			6.0	2.64
BHX1262V5...		6 000							12.0	5.28
BHX1263R5...	11	4 500	1.58	1.72	10.6	12.1	10.0	5.18		
BHX1552N5...	[12]	3 000	[2.45]	[2.72]	[11.3]	[12.9]	22	0.8		[3.77]
BHX1552R5...		4 500								[5.65]
BHX1554N5...	[20]	3 000	[4.76]	[5.03]	[17.8]	[19.4]				[6.28]

[...] Preliminary

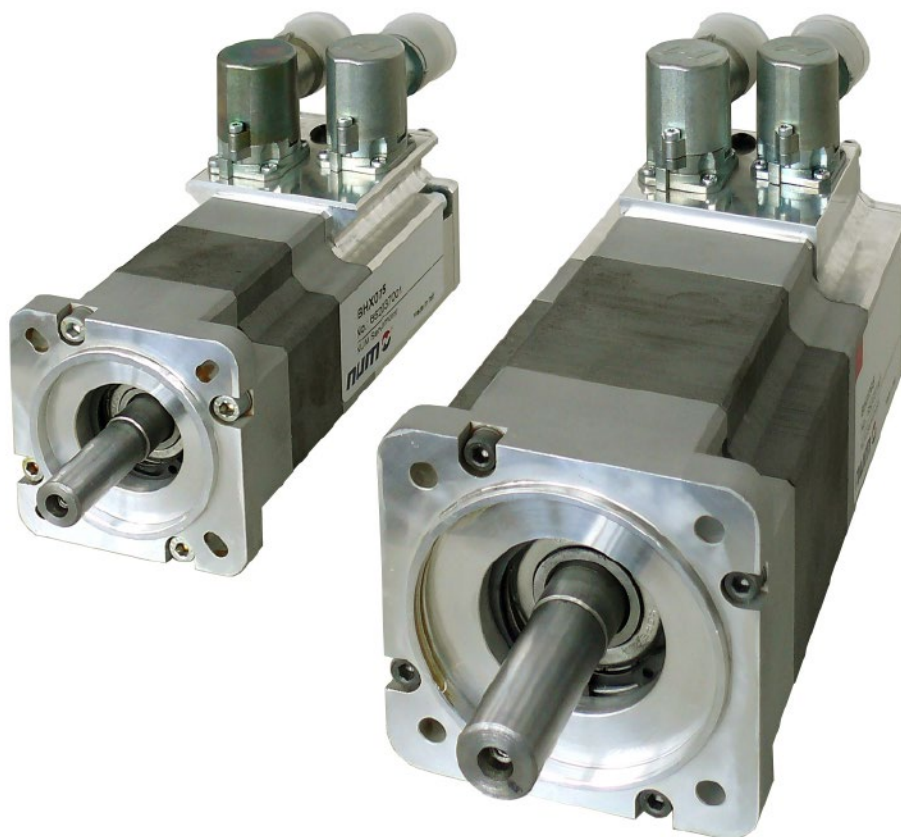

# NUM Motors

NUM Motors BHX, BPX, BPH, BPG, BHL, AMS, IM Spindle Motors, AMR

NUM Motors BHX, BPX, BPH, BPG, BHL  
Technical Characteristics

## BPX Motors

For peak torque figures please refer to chapter 7 where the drive-motor associations are described.

	Low speed cont. torque	Rated speed	Rotor Inertia		Motor weight		Brake		Low speed cont. current	Dimensioning Power
			without brake	with brake	without brake	with brake	Torque	Current		
	[Nm]	[rpm]	[g.m <sup>2</sup> ]	[g.m <sup>2</sup> ]	[kg]	[kg]	[Nm]	[A]	[Arms]	[kW]
BPX0551V5...	0.5	6 000	0.006	0.008	1.2	1.4	0.8	0.4	0.7	0.31
BPX0751V5...	1.4	6 000	0.07	0.08	2.2	2.4	2.2	0.4	2.0	0.88
BPX0752V5...	2.3	6 000	0.13	0.14	3.2	3.4	6	0.7	3.4	1.45
BPX0951V5...	2.7	6 000	0.20	0.26	3.6	4.3			3.4	1.70
BPX0952N5...	5.0	3 000	0.37	0.43	5.2	5.9	13	0.8	3.3	1.57
BPX0952V5...		6 000							6.6	3.14
BPX1261N5...	5.2	3 000	0.55	0.69	6.0	7.5	13	0.8	3.7	1.63
BPX1261V5...		6 000							7.4	3.27
BPX1262N5...	9.8	3 000	1.07	1.21	8,5	10	13	0.8	7.0	3.08
BPX1262V5...		6 000							14.0	6.16
BPX1263R5...	12.6	4 500	1.58	1.72	11.2	12.7	22	0.8	11.5	5.94
BPX1552N5...	[13.8]	3 000	[2.45]	[2.72]	[12.0]	[13.6]			[4.34]	
BPX1552R5...		4 500							[6.50]	
BPX1554N5...	[23]	3 000	[4.76]	[5.03]	[18.6]	[20.2]				[7.23]

[...] Preliminary

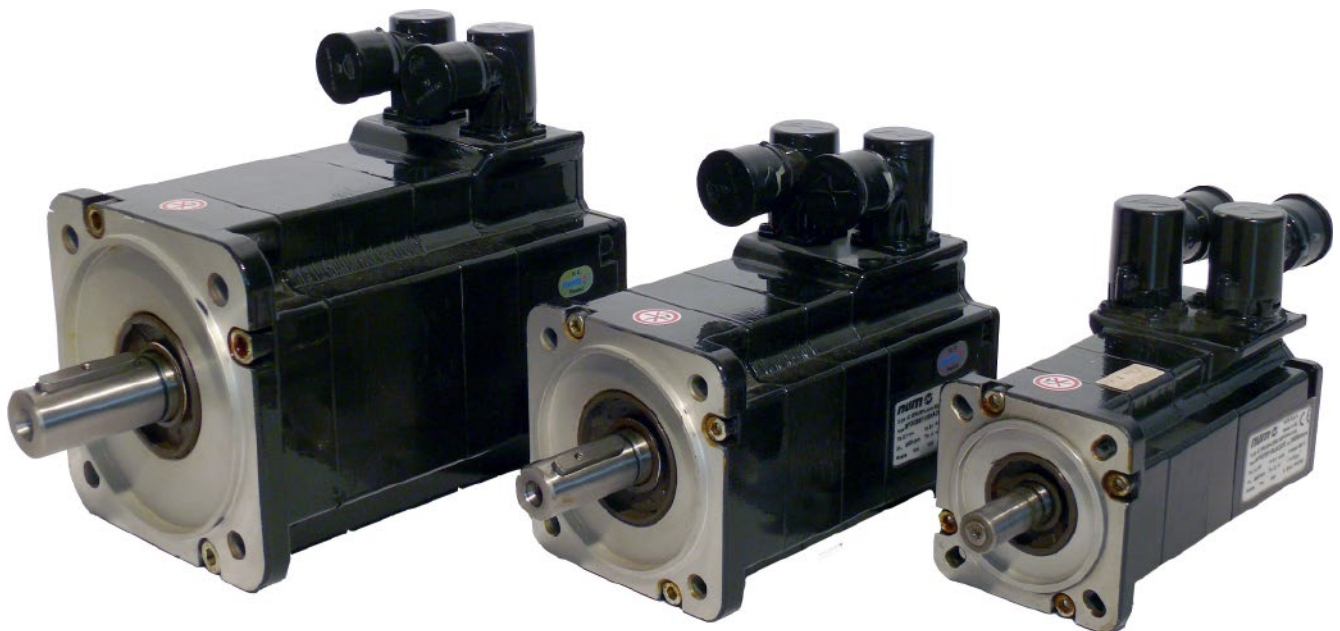

# NUM Motors

NUM Motors BHX, BPX, BPH, BPG, BHL, AMS, IM Spindle Motors, AMR

NUM Motors BHX, BPX, BPH, BPG, BHL  
Technical Characteristics

## BPH Motors

For peak torque figures please refer to chapter 7 where the drive-motor associations are described.

BPH	Low speed cont. torque	Rated speed	Rotor Inertia		Motor weight		Brake		Low speed cont. current	Dimensioning power
			without brake	with brake	without brake	with brake	Torque	Current		
	[Nm]	[rpm]	[g.m <sup>2</sup> ]	[g.m <sup>2</sup> ]	[kg]	[kg]	[Nm]	[A]	[Arms]	[kW]
BPH0751N5...	1.3	3 000	0.08	0.12	3.5	3.85	2.5	0.5	2.2	0.41
BPH0751V5...		6 000							3	0.82
BPH0752N5...	2.3	3 000	0.12	0.16	4.3	4.65	5	0.7	2.7	0.72
BPH0752V5...		6 000							3.5	1.45
BPH0754N5...	4	3 000	0.21	0.25	6	6.35	11	0.8	3.5	1.26
BPH0952N5...	4.3	3 000	0.3	0.41	6.7	7.5			5.9	2.70
BPH0952V5...		6 000					5.2	1.88		
BPH0953N5...	6	3 000	0.41	0.52	8	8.8	12	0.8	10.3	3.77
BPH0953V5...		6 000							5.8	2.89
BPH0955N5...	9.2	3 000	0.64	0.75	10.5	11.3	20	1	5.5	2.32
BPH1152N5...	7.4	3 000	0.7	1.07	9.6	10.9			10.5	4.65
BPH1152V5...		6 000					10.5	4.65		
BPH1153K5...	10.5	2 000	0.97	1.34	11.7	13	22	1.5	5.3	2.20
BPH1153N5...		3 000							9.2	3.30
BPH1153V5...		6 000							12.6	6.60
BPH1154K5...		2 000							6.2	2.79
BPH1154N5...	13.3	3 000	1.25	1.62	13.8	15.1	40	1.5	10.1	4.18
BPH1154V5...		6 000							17.6	8.36
BPH1156N5...	18.7	3 000	1.8	2.17	17.9	19.2	80	1.5	12	5.87
BPH1422K5...	12	2 000	1.59	2.54	17.2	19.4			20	6
BPH1422N5...		3 000					10.4	3.77		
BPH1422R5...		4 250					11.5	5.34		
BPH1423K5...		2 000					2.19	3.14	20.1	22.3
BPH1423N5...	17	3 000	2.19	3.14	20.1	22.3	40	1.5	11.7	5.34
BPH1423R5...		4 250							16.9	7.57
BPH1424K5...	22	2 000	2.79	3.74	23	25.2	80	1.5	10.4	4.61
BPH1424N5...		3 000							15.6	6.91
BPH1424R5...		4 250							20.8	9.79
BPH1427N5...	35	3 000	4.29	5.24	31.7	33.9	80	1.5	24.2	11.00
BPH1902K5...	25	2 000	5.14	8.25	32.1	36.2			16.6	5.24
BPH1902N5...		3 000					19.9	7.85		
BPH1902R5...		4 250					29.2	11.13		
BPH1903K5...		2 000					7.1	10.2	37.3	41.4
BPH1903N5...	36	3 000	7.1	10.2	37.3	41.4	80	1.5	27.8	11.31
BPH1904K5...		2 000							9.04	12.1
BPH1904N5...	46	3 000	9.04	12.1	42.4	46.5	80	1.5	30.3	14.45
BPH1905H5...		1 500							11	14.1
BPH1905L5...	56	2 500	11	14.1	47.6	51.7	80	1.5	31.4	14.66
BPH1907K5...		2 000							14.9	18
BPH1907N5...	75	3 000	14.9	18	58	62.1	80	1.5	52.3	23.56
BPH190AK5...		2 000							20.75	23.8

5



# NUM Motors

NUM Motors BHX, BPX, BPH, BPG, BHL, AMS, IM Spindle Motors, AMR

NUM Motors BHX, BPX, BPH, BPG, BHL  
Technical Characteristics

## BPG Motors

For peak torque figures please refer to chapter 7 where the drive-motor associations are described

BPG	Low speed cont. torque	Rated speed	Rotor Inertia		Motor weight		Brake		Low speed cont. current	Dimensioning power
	[Nm]		[rpm]	without brake	with brake	without brake	with brake	Torque		
			[g.m <sup>2</sup> ]	[g.m <sup>2</sup> ]	[kg]	[kg]	[Nm]	[A]	[Arms]	[kW]
BPG0751N5...	1.3	3 000	0.25		4				2.2	0.41
BPG0752N5...	2.3	3 000	0.3		4.8				2.7	0.72
BPG0952N5...	4.3	3 000	0.86		7.6				3.5	1.35
BPG0953N5...	6	3 000	0.97		8.9				5.2	1.88
BPG1152N5...	7.4	3 000	2.45		11.2				5.5	2.32
BPG1153K5...	10.5	2 000	2.73		13.3				5.3	2.20
BPG1153N5...		3 000							9.2	3.30
BPG1153V5...		6 000							12.6	6.60
BPG1422N5...	12	3 000	6.7		20.4				10.4	3.77
BPG1423N5...	17	3 000	7.3		23.3				11.7	5.34
BPG1424K5...	22	2 000	7.9		26.2				10.4	4.61
BPG1424R5...		4 250							20.8	9.79
BPG1427N5...	35	3 000	9.7		34.9				24.2	11.00
BPG1902K5...	25	2 000	20.9		38.1				16.6	5.24
BPG1902N5...		3 000							19.9	7.85
BPG1903K5...	36	2 000	22.9		43.3				19.7	7.54
BPG1903N5...		3 000							27.8	11.31
BPG1904N5...		3 000							30.3	14.45
BPG1905L5...	56	2 500	26.8		53.6				31.4	14.66

## BHL Motors

For peak torque figures please refer to chapter 7 where the drive-motor associations are described

BHL	Low speed cont. torque	Rated speed	Rotor Inertia		Motor weight		Brake		Low speed cont. current	Dimensioning power
	[Nm]		[rpm]	without brake	with brake	without brake	with brake	Torque		
			[g.m <sup>2</sup> ]	[g.m <sup>2</sup> ]	[kg]	[kg]	[Nm]	[A]	[Arms]	[kW]
BHL2601N5...	85	3 000	45	48.1	95	99	80	1.5	52	26.70
BHL2601N1...*	120				100	104			75	37.70
BHL2602K5...	120	2 000	66.2	69.3	126	130			52	25.13
BHL2602K1...*	160				131	135			69.3	33.51

\* = BHL motors with forced convection (V) require an auto-transformer for 480Vac network (code: AMOTRF001)

# NUM Motors

NUM Motors BHX, BPX, BPH, BPG, BHL, AMS, IM Spindle Motors, AMR

NUM Motors BHX, BPX, BPH, BPG, BHL  
Outline Drawings BHX Motors

## Outline Drawings BHX / BPX Motors

**bhx bpx**

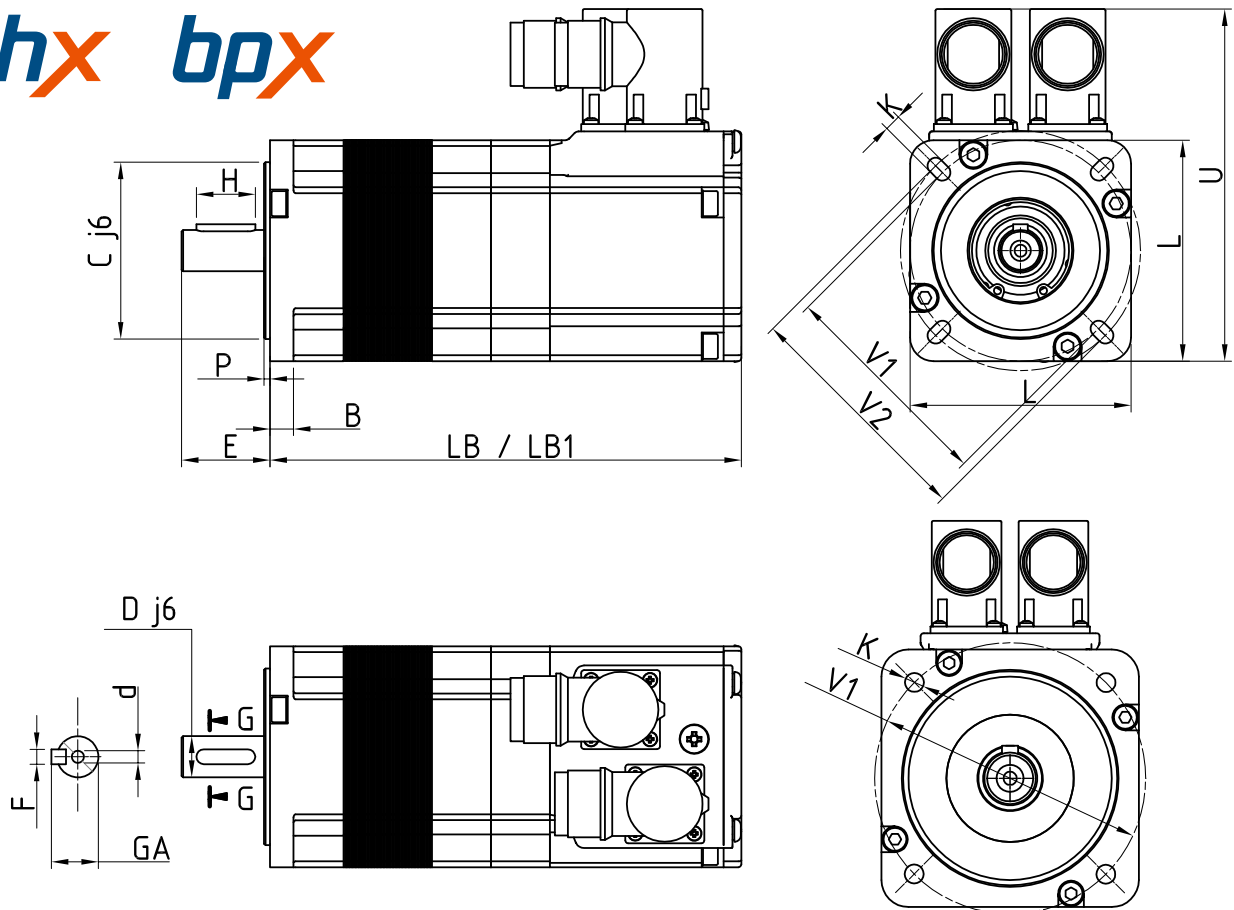

5

Dimensions in mm

BHX / BPX		L	LB*	LB1*	C	P	B	V1	V2	K	U	D	E	H	F	GA	d
		mm	mm	mm	mm	mm	mm	mm	mm	mm	mm	mm	mm	mm	mm	mm	mm
075	1	75	140	160	60	2.5	8	75	81.5	5.5	120	14	30	20	5	16	M5x10
	2		170	190													
095	1	95	153	183	80	3	10	100	---	7	143	19	40	30	6	21.5	M6x16
	2		183	213													
126	1	126	149	194	110	3.5	11	130	---	9	175	24	50	40	8	27	M8x19
	2		179	224													
	3		209	254													
155	2	155	190	240	130	3.5	13	165	---	11	200	32	58	45	10	35	M12x28
	4		240	290													

\*= LB without brake, LB1 with brake

# NUM Motors

NUM Motors BHX, BPX, BPH, BPG, BHL, AMS, IM Spindle Motors, AMR

NUM Motors BHX, BPX, BPH, BPG, BHL  
Outline Drawings BHX Motors

## Outline Drawings BHX / BPX Motors

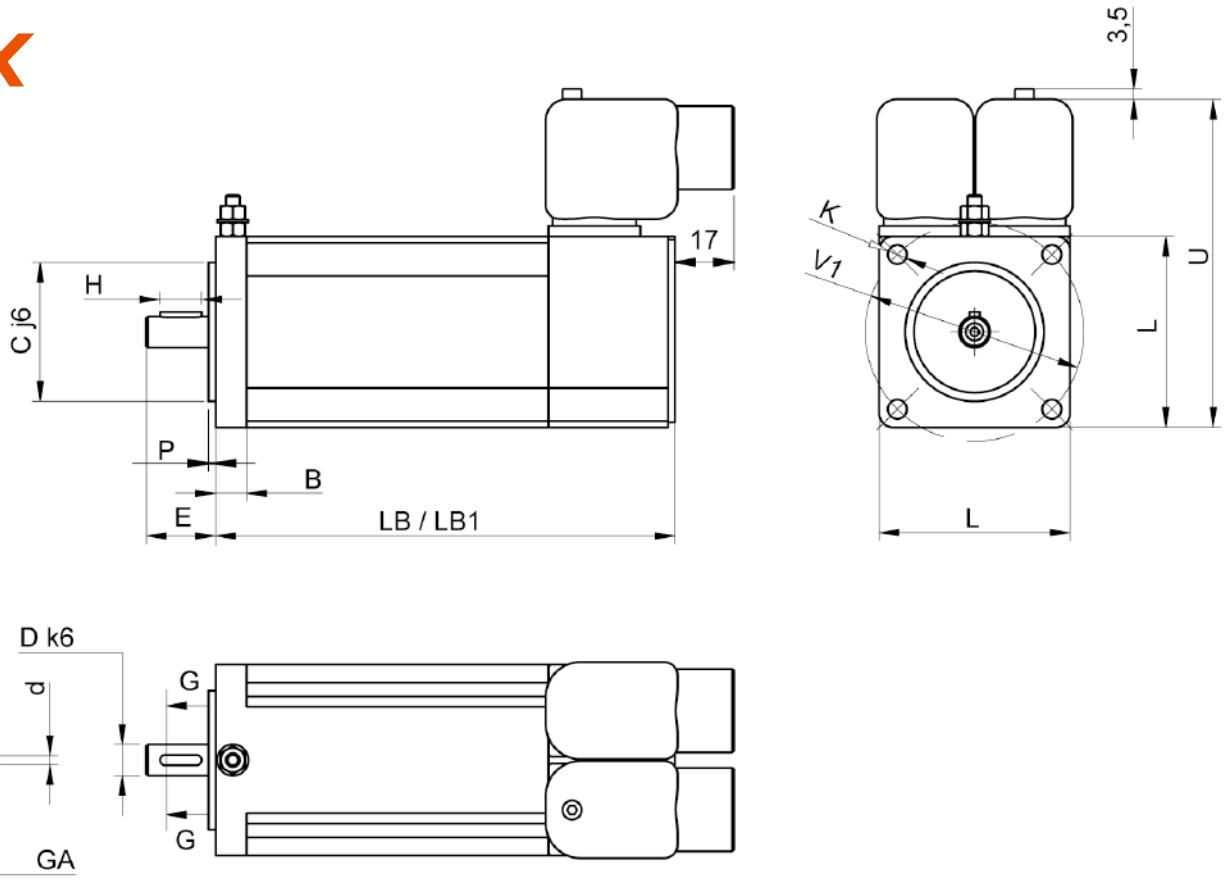

Dimensions in mm

BPX		L	LB*	LB1*	C	P	B	V1	K	U	D	E	H	F	GA	d
		mm	mm	mm	mm	mm	mm	mm	mm	mm	mm	mm	mm	mm	mm	mm
055	1	55	133	159	40	2	9	63	5.5	94.5	9	20	12	3	10.2	M3 x 9

\*= LB without brake, LB1 with brake

# NUM Motors

NUM Motors BHX, BPX, BPH, BPG, BHL, AMS, IM Spindle Motors, AMR

NUM Motors BHX, BPX, BPH, BPG, BHL  
Outline Drawings BPH and BPG Motors

## Outline Drawings BPH and BPG Motors

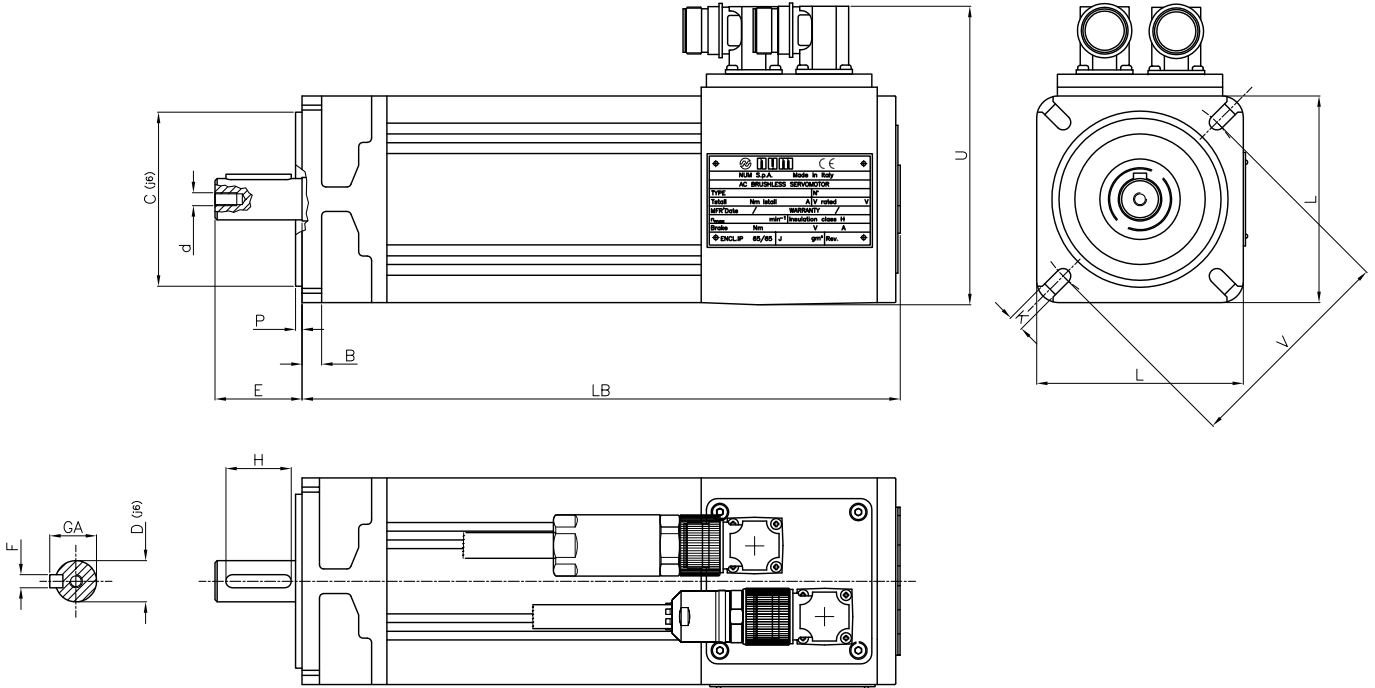

Dimensions in mm

BPH BPG		BPH shaft								BPG shaft											
		L	LB***	C	P	B	V	K	U	D	E	H	F	GA	d	D	E	H	F	GA	d
		mm	mm	mm	mm	mm	mm	mm	mm	mm	mm	mm	mm	mm	mm	mm	mm	mm	mm	mm	mm
075	1	75	221	60	2.5	8	75	6	117	11	23	15	4	12.5	M4x10	14	30	20	5	16	M5x12
	2		250							14	30	20	5	16	M5x12						
	4		308																		
095	2	95	275	80	3	9	100	7	137	19	40	30	6	21.5	M6x16	19	40	30	6	21.5	M6x16
	3		304																		
	5		362																		
115	2	115	290	95	3	10	115	9	166	19	40	30	6	21.5	M6x16	24	50	40	8	27	M8x19
	3		319							24	50	40	8	27	M8x19						
	4		348																		
	6		406																		
142	2	142	316	130	3	14	165	11	193	24	50	40	8	27	M8x19	32	58	45	10	35	M12x28
	3		345																		
	4		374																		
	7		461							32	58	45	10	35	M12x28						
190	2	190	355	180	3	17	215	14	242* or 258**	32	58	45	10	35	M12x28	38	80	70	10	41	M12x28
	3		384																		
	4		413																		
	5		442																		
	7		500							38	80	70	10	41	M12x28						
	A		605																		

\* 190 2K. 2N. 3K. 4K. 5H

\*\* 190 2R. 3N. 4N. 5L. 7K. AK

\*\*\* BPH length doesn't change with or without brake

# NUM Motors

NUM Motors BHX, BPX, BPH, BPG, BHL, AMS, IM Spindle Motors, AMR

NUM Motors BHX, BPX, BPH, BPG, BHL  
Outline Drawings BHL Motors

## Outline Drawings BHL Motors

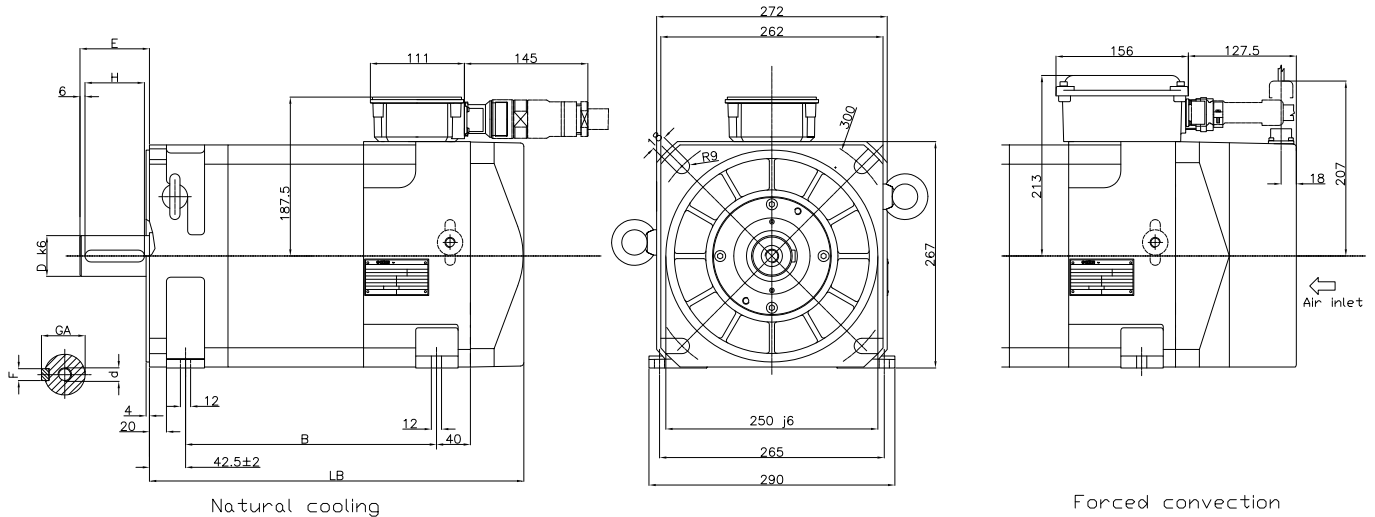

Dimensions in mm

	LB	B	D	E	H	F	GA	d
	mm	mm	mm	mm	mm	mm	mm	mm
BHL2601x5xx2...	440	296 ± 2	48	82 ± 1	70	14	51.5	M16x36
BHL2601x1xxV...	521	296 ± 2	48	82 ± 1	70	14	51.5	M16x36
BHL2602x5xx2...	510	366 ± 2	48	82 ± 1	70	14	51.5	M16x36
BHL2602x1xxV...	591	366 ± 2	48	82 ± 1	70	14	51.5	M16x36

# NUM Motors

NUM Motors BHX, BPX, BPH, BPG, BHL, AMS, IM Spindle Motors, AMR

NUM Motors BHX, BPX, BPH, BPG, BHL  
Ordering Codes

## BHX Motors

	<b>BHX</b>	<b>075</b>	<b>1</b>	<b>N</b>	<b>5</b>	<b>Q</b>	<b>A</b>	<b>2</b>	<b>L</b>	<b>0</b>	<b>0</b>
<b>Series</b>											
<b>Size (075, 095, 126)</b>											
<b>Length</b>											
<b>Winding type</b>											
<b>Connection type</b>											
- Standard right-angled M23 rotatable connectors					5						
<b>Sensor type</b>											
- High resolution multi-turn encoder						P					
- High resolution single-turn encoder						Q					
- Medium resolution multi-turn encoder						J					
- Medium resolution single-turn encoder						K					
<b>Brake</b>											
- Without brake							A				
- With brake							F				
<b>Fixed value</b>								2			
<b>Shaft extension</b>											
- Smooth									L		
- Keyed									C		
<b>Fixed value</b>										0	
<b>Degree of protection (shaft extension/frame)</b>											
- IP 54/64 (standard version)											0

## BPX Motors

	<b>BPX</b>	<b>075</b>	<b>1</b>	<b>N</b>	<b>5</b>	<b>K</b>	<b>A</b>	<b>2</b>	<b>L</b>	<b>0</b>	<b>2</b>
<b>Series</b>											
<b>Size (055, 075, 095, 126, 155)</b>											
<b>Length</b>											
<b>Winding type</b>											
<b>Connection type</b>											
- Standard right-angled M23 rotatable connectors					5						
<b>Sensor type <sup>(1)</sup></b>											
- High resolution multi-turn encoder						P					
- High resolution single-turn encoder						Q					
- Medium resolution multi-turn encoder						J					
- Medium resolution single-turn encoder						K					
<b>Brake</b>											
- Without brake							A				
- With brake							F				
<b>Fixed value</b>								2			
<b>Shaft extension</b>											
- Smooth <sup>(2)</sup>									L		
- Keyed									C		
<b>Fixed value</b>										0	
<b>Degree of protection (shaft extension/frame)</b>											
- IP 65/65 (only for BPX055) <sup>(3)</sup>											1
- IP 67/67 (not for BPX055)											2

<sup>(1)</sup> BPX055 only "J" encoder

<sup>(2)</sup> Not available for BPX055. Smooth shaft could be obtained with machined key sold with the keyed motor

<sup>(3)</sup> IP 67/67 could be reached with air pressure barrier

# NUM Motors

NUM Motors BHX, BPX, BPH, BPG, BHL, AMS, IM Spindle Motors, AMR

NUM Motors BHX, BPX, BPH, BPG, BHL  
Ordering Codes

## BPH Motors

	BPH	075	1	N	5	Q	A	2	L	0	1
<b>Series</b>											
<b>Size</b>	(075, 095, 115, 142, 190)										
<b>Length</b>											
<b>Winding type</b>											
<b>Fixed value</b>	5										
<b>Sensor type</b>											
- High resolution multi-turn encoder	P										
- High resolution single-turn encoder	Q										
- Medium resolution multi-turn encoder	J										
- Medium resolution single-turn encoder	K										
<b>Brake</b>											
- Without brake	A										
- With brake	F										
<b>Fixed value</b>	2										
<b>Shaft extension</b>											
- Smooth	L										
- Keyed	C										
<b>Fixed value</b>	0										
<b>Degree of protection (shaft extension/frame)</b>											
- IP 65/65	1										
- IP 67/67 option	2										

## BPG Motors

	BPG	075	1	N	5	Q	A	2	L	0	1
<b>Series</b>											
<b>Size</b>	(075, 095, 115, 142, 190)										
<b>Length</b>											
<b>Winding type</b>											
<b>Fixed value</b>	5										
<b>Sensor type</b>											
- High resolution multi-turn encoder	P										
- High resolution single-turn encoder	Q										
- Medium resolution multi-turn encoder	J										
- Medium resolution single-turn encoder	K										
<b>Brake</b>											
- Brake not available	A										
<b>Fixed value</b>	2										
<b>Shaft extension</b>											
- Smooth	L										
- Keyed	C										
<b>Fixed value</b>	0										
<b>Degree of protection (shaft extension/frame)</b>											
- IP 65/65	1										
- IP 67/67 option	2										

# NUM Motors

NUM Motors BHX, BPX, BPH, BPG, BHL, AMS, IM Spindle Motors, AMR

NUM Motors BHX, BPX, BPH, BPG, BHL  
Ordering Codes

## BHL Motors

	BHL	260	1	N	1	Q	A	2	L	0	5
<b>Series</b>											
<b>Size</b>											
<b>Length</b>											
<b>Winding type</b>											
<b>Power connection</b>											
- With terminal box mandatory for forced convection version					1						
- With power connector mandatory for natural convection version					5						
<b>Sensor type</b>											
- High resolution multi-turn encoder						P					
- High resolution single-turn encoder						Q					
<b>Brake</b>											
- Without brake							A				
- With brake							F				
<b>Cooling</b>											
- Natural convection								2			
- With fan (ventilated)								V			
<b>Shaft extension</b>											
- Smooth									L		
- Keyed									C		
<b>Fixed value</b>										0	
<b>Degree of protection (shaft extension/frame/fan if present)</b>											
- IP 54/65/54											5

5



# NUM Motors

NUM Motors BHX, BPX, BPH, BPG, BHL, AMS, IM Spindle Motors, AMR

NUM Motors BHX, BPX, BPH, BPG, BHL

Ordering Codes

Accessories

## BHX connectors, cables and cable assemblies

	Connectors		Cables		Cable assemblies*	
	Power	Sensor	Power	Sensor	Power	Sensor
BHX0751V5...	AMOC0N004D	AMOC0N002D	PC015xy00	SC007SH00	PC015xy4zMnnnn	SC007SH2wMnnnn
BHX0752V5...						
BHX0951V5...						
BHX0952N5...						
BHX0952V5...						
BHX1261N5...						
BHX1261V5...						
BHX1262N5...						
BHX1262V5...						
BHX1263N5...						
BHX1263R5...						
BHX1552N5...						
BHX1552R5...						
BHX1554N5...						

\* note for the cable assemblies see below:

## BPX connectors, cables and cable assemblies

	Connectors		Cables		Cable assemblies*	
	Power	Sensor	Power	Sensor	Power	Sensor
BPX0551V5...	AMOC0N004D	AMOC0N002D	PC015xy00	SC007SH00	PC015xy4zMnnnn	SC007SH2wMnnnn
BPX0751V5...						
BPX0752V5...						
BPX0951V5...						
BPX0952N5...						
BPX0952V5...						
BPX1261N5...						
BPX1261V5...						
BPX1262N5...						
BPX1262V5...						
BPX1263N5...						
BPX1263R5...						
BPX1552N5...						
BPX1552R5...						
BPX1554N5...						

\* note for the cable assemblies see below:

x: cable with or without brake wires  
 x = B for cable with brake wires  
 x = N for cable without brake wires

y: cable performance  
 y = H for High performance cable  
 y = L for Basic performance cable

z: power connector on drive side  
 z = 0 Without connector  
 z = 1 with connector AEOCON009  
 z = 2 with connector AEOCON013

w: sensor connector on drive side  
 w = 0 Without connector  
 w = 3 with connector AEOCON012  
 w = 4 with connector AEOCON012 reversed

nnnn cable length in 0.1m  
 nnnn = 0105 = 10.5m

# NUM Motors

NUM Motors BHX, BPX, BPH, BPG, BHL, AMS, IM Spindle Motors, AMR

NUM Motors BHX, BPX, BPH, BPG, BHL  
Accessories

## BPH connectors, cables and cable assemblies

	Connectors		Cables		Cable assemblies*	
	Power	Sensor	Power	Sensor	Power	Sensor
BPH0751N5...	AMOCON004D		PC015xy00		PC015xy4zMnnnn	
BPH0751V5...						
BPH0752N5...						
BPH0752V5...						
BPH0754N5...						
BPH0952N5...						
BPH0952V5...						
BPH0953N5...						
BPH0953V5...						
BPH0955N5...						
BPH1152N5...						
BPH1152V5...						
BPH1153K5...						
BPH1153N5...						
BPH1153V5...						
BPH1154K5...						
BPH1154N5...						
BPH1154V5...						
BPH1156N5...						
BPH1422K5...						
BPH1422N5...						
BPH1422R5...						
BPH1423K5...						
BPH1423N5...						
BPH1423R5...						
BPH1424K5...						
BPH1424N5...						
BPH1424R5...						
BPH1427N5...						
BPH1902K5...						
BPH1902N5...						
BPH1902R5...						
BPH1903K5...						
BPH1903N5...						
BPH1904K5...						
BPH1904N5...						
BPH1905H5...						
BPH1905L5...						
BPH1907K5...						
BPH1907N5...						
BPH190AK5...						
	AMOCON005D		PC100xy00		PC100xy5zMnnnn	
	AMOCON004D		PC040xy00		PC040xy4zMnnnn	
	AMOCON005D		PC100xy00		PC100xy5zMnnnn	
	AMOCON004D		PC040xy00		PC040xy4zMnnnn	
	AMOCON005D		PC100xy00		PC100xy5zMnnnn	
	AMOCON004D		PC040xy00		PC040xy4zMnnnn	
	AMOCON005D		PC040xy00		PC040xy4zMnnnn	
	AMOCON005D		PC100xy00		PC100xy5zMnnnn	

\* note for the cable assemblies see below:

x: cable with or without brake wires  
x = B for cable with brake wires  
x = N for cable without brake wires

y: cable performance  
y = H for High performance cable  
y = L for Basic performance cable

z: power connector on drive side  
z = 0 Without connector  
z = 1 with connector AEOCON009  
z = 2 with connector AEOCON013

w: sensor connector on drive side  
w = 0 Without connector  
w = 3 with connector AEOCON012  
w = 4 with connector AEOCON012 reversed

n n n n cable length in 0.1m  
n n n n = 0105 = 10.5m

# NUM Motors

NUM Motors BHX, BPX, BPH, BPG, BHL, AMS, IM Spindle Motors, AMR

NUM Motors BHX, BPX, BPH, BPG, BHL  
Accessories

## BPG connectors, cables and cable assemblies

	Connectors		Cables		Cable assemblies*	
	Power	Sensor	Power	Sensor	Power	Sensor
BPG0751N5...	AMOCOCON004D	AMOCOCON002D	PC015Ny00		PC015Ny4zMnnnn	
BPG0752N5...						
BPG0952N5...						
BPG0953N5...						
BPG1152N5...						
BPG1153K5...			SC007SH00			SC007SH2wMnnnn
BPG1153N5...						
BPG1153V5...						
BPG1422N5...						
BPG1423N5...						
BPG1424K5...			PC040Ny00			
BPG1424R5...						
BPG1427N5...						
BPG1902K5...						
BPG1902N5...						
BPG1903K5...	AMOCOCON005D		PC100Ny00		PC100Ny5zMnnnn	
BPG1903N5...						
BPG1904N5...						
BPG1905L5...						

\* note for the cable assemblies see below

## BHL connectors, cables and cable assemblies

	Connectors			Cables		
	Power	Sensor	Fan	Power	Sensor	Fan
BHL2601N5...	AMOCOCON005D	AMOCOCON002D	CONN113D00	PC100xH00	SC007SH00	NC010NL00
BHL2601N1...	None			PC215BH00		
BHL2602K5...	AMOCOCON005D			PC100xH00		
BHL2602K1...	None			PC215BH00		

	Cable assemblies*		
	Power	Sensor	Fan
BHL2601N5...	PC100xH50Mnnnn	SC007SH2wMnnnn	NC010NL70Mnnnn
BHL2601N1...	PC215BH00		
BHL2602K5...	PC100xH50Mnnnn		
BHL2602K1...	PC215BH00		

\* note for the cable assemblies see below

x: cable with or without brake wires  
x = B for cable with brake wires  
x = N for cable without brake wires

y: cable performance  
y = H for High performance cable  
y = L for Basic performance cable

z: power connector on drive side  
z = 0 Without connector  
z = 1 with connector AEOCON009  
z = 2 with connector AEOCON013

w: sensor connector on drive side  
w = 0 Without connector  
w = 3 with connector AEOCON012  
w = 4 with connector AEOCON012 reversed

nnnn cable length in 0.1m  
nnnn = 0105 = 10.5m

# NUM Motors

NUM Motors BHX, BPX, BPH, BPG, BHL, AMS, IM Spindle Motors, AMR

NUM Motors BHX, BPX, BPH, BPG, BHL  
Accessory Descriptions

## Accessory Descriptions

AMOC0N004D	6 poles power connector *
AMOC0N005D	6 poles power connector *
AMOC0N002D	17 poles encoder connector *
PC015BH00	High performance power cable with brake wires (4 x 1.5 mm <sup>2</sup> + (2 x 1.5 mm <sup>2</sup> )) *
PC040BH00	High performance power cable with brake wires (4 x 4 mm <sup>2</sup> + (2 x 1.5 mm <sup>2</sup> )) *
PC100BH00	High performance power cable with brake wires (4 x 10 mm <sup>2</sup> + (2 x 1.5 mm <sup>2</sup> )) *
PC215BH00	High performance power cable with brake wires (4 x AWG04 + (2 x 1.5 mm <sup>2</sup> )) *
PC015NL00	Basic performance power cable without brake wires (4 x 1.5 mm <sup>2</sup> )
PC040NL00	Basic performance power cable without brake wires (4 x 4 mm <sup>2</sup> )
SC007SH00	High performance Sensor cable (3 x (2 x 0.14 mm <sup>2</sup> ) + 4 x 0.14 mm <sup>2</sup> + 2 x 0.5 mm <sup>2</sup> ) *
NC010NL00	Standard cable (4 x 1.5 mm <sup>2</sup> )
AMOTRF001	Auto-transformer for fan needed in case of 480 Vac mains

\* See association tables on pages 96 to 98

# NUM Motors

NUM Motors BHX, BPX, BPH, BPG, BHL, AMS, IM Spindle Motors, AMR  
NUM Motors AMS and IM  
General Characteristics

## NUM Motors AMS and IM

The AMS asynchronous motors are designed to control machine tool spindles as well as C axis application thanks to an high resolution encoder.

They are compact (with built-in axial fan) and exhibit low rotor inertia.

AMS associated to a NUM Drive with flux vector control ensure very smooth rotation, even at low speeds.

For applications requiring very high radial loads, AMS motors (size 132 and 160) can fulfil this need by a specific version available as an option.

## General Characteristics

Temperatur	- 20 bis + 80 °C
Relative Feuchtigkeit	max. 80% ohne Kondensation
Betriebsbedingungen:	
Temperatur	0 bis 40 °C ohne, max. 55 °C mit Leistungseinbusse
Einsatzhöhe	0 bis 1000 m ohne, max. 3000 m mit Leistungseinbusse
Leistungsbereich	von 3,7 bis 55 kW Nennleistung
Schutzart nach EN60529	IP65 Gehäuse IP54 Lüfter IP54 Welle, optional IP65
Anschluss	Netz: Anschlussklemmen Geber: Stecker
Motorgeber	Singleturn / Multiturn-Geber (optisch), hohe Auflösung
Zulässige Montagepositionen	Keine Restriktionen, IMB5 - IMV1 - IMV3 nach EN60034-7
Vibrationsklasse nach EN60034-14	R, optional S
Lüfter Eingangsspannung	400 VAC ± 5% 3-Phasen, 50/60 Hz (AMS motor) 220 VAC ± 5% 1-Phasen, 50/60 Hz (IM motor)

# NUM Motors

NUM Motors BHX, BPX, BPH, BPG, BHL, AMS, IM Spindle Motors, AMR

## NUM Motors AMS and IM Technical Characteristics

### AMS Motors

For power curves refer to the chapter 7 where the drive-motors associations are described.

AMS	Connection type	Rate Continuous Power	Rated Speed	Max Speed	Rated Torque	Rated Continuous Current	Rotor Inertia	Fan (3 Phases)		Motor weight
								Voltage	Current	
		[kW]	[rpm]	[rpm]	[Nm]	[Arms]	[g.m <sup>2</sup> ]	[V]	[Arms]	[Kg]
AMS100SB1...	Y	3.7	1500	6500	24	20	9	400	0.11	37
AMS100MB1...	Y	5.5			35	26	14			49
AMS100GB1...	Y	9			57	39	23			71
AMS100SD1...	Y	3.7	12000		24	20	9			37
AMS100MD1...	Y	5.5			35	26	14			49
AMS100GD1...	Y	9			57	39	23			71
AMS132SA1...	Y	5	750	7000	64	26	55	0.2	105	
AMS132SC1...	Y	10	1500		64	39				
AMS132SE1...	Δ	15	1750	82	52					
AMS132MA1...	Y	7.5	750	95	39	75	131			
AMS132MC1...	Y	15	1500	95	52					
AMS132ME1...	Δ	19.5	2000	100	72					
AMS132LA1...	Y	11	750	140	52	113	183			
AMS132LE1...	Y	22	1250	168	72					
AMS132SF1...	Y	5	750	10000	64	26	55		105	
AMS132SG1...	Y	10	1500		64	39				
AMS132SH1...	Δ	15	1750		82	52				
AMS132MF1...	Y	7.5	750		95	39	75	131		
AMS132MG1...	Y	15	1500		95	52				
AMS132MH1...	Δ	19.5	2000		100	72				
AMS132LF1...	Y	11	750	9000	140	52	113	183		
AMS132LI1...	Y	12.5	680		175	39				
AMS132LH1...	Y	22	1250		168	72				
AMS160MA1...	Y	18	650		8500	264	52	250	0.3	215
	Δ		1300	132						
AMS160MB1...	Y	26	1200	208		72				
	Δ		2400	104						
AMS160MC1...	Δ	36	1700	202		100				
AMS160LA1...	Y	18	500	6500		344	52			
	Δ		1000		172					
AMS160LB1...	Y	26	950		260	72				
	Δ		1900		130					
AMS160LC1...	Δ	36	1050		328	100				

AMS require an auto-transformer for 480Vac mains (code: AMOTRF001)

### IM Motor

For power curves refer to the chapter 7 where the drive-motors associations are described.

IM	Connection type	Rate Continuous Power	Rated Speed	Max Speed	Rated Torque	Rated Continuous Current	Rotor Inertia	Fan (1 Phase)		Motor weight
								Voltage	Current	
		[kW]	[rpm]	[rpm]	[Nm]	[Arms]	[g.m <sup>2</sup> ]	[V]	[Arms]	[Kg]
IM18MK14...	YY	55	1050	7500	500	145	570	230	0.8	415

# NUM Motors

NUM Motors BHX, BPX, BPH, BPG, BHL, AMS, IM Spindle Motors, AMR

NUM Motors AMS and IM  
Outline Drawings AMS Motors

## Outline Drawings AMS Motors

### AMS Motor Shaft End

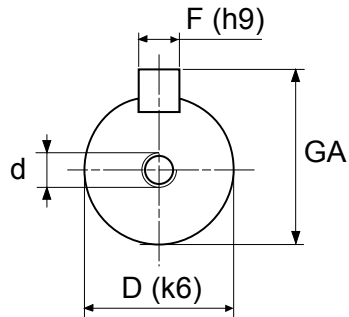

	LB	B	Shaft					
			D	E	W	F	GA	d
	mm	mm	mm	mm	mm	mm	mm	mm
100 S	388	$179 \pm 1.5$	32	60	50	10	35	M12x30
100 M	442	$233 \pm 1.5$	38	80	70	12	41	
100 G	535	$326 \pm 1.5$						
132 S	521	$296 \pm 2$	42	110	90	12	45	M16x36
132 M	591	$366 \pm 2$	48	110	90	14	51.5	
132 L	721	$496 \pm 2$						
160 M	682	$385 \pm 2$	55	110	90	16	59	M20x42
160 L	827	$530 \pm 2$						

Dimensions in mm

### AMS 100 Motor

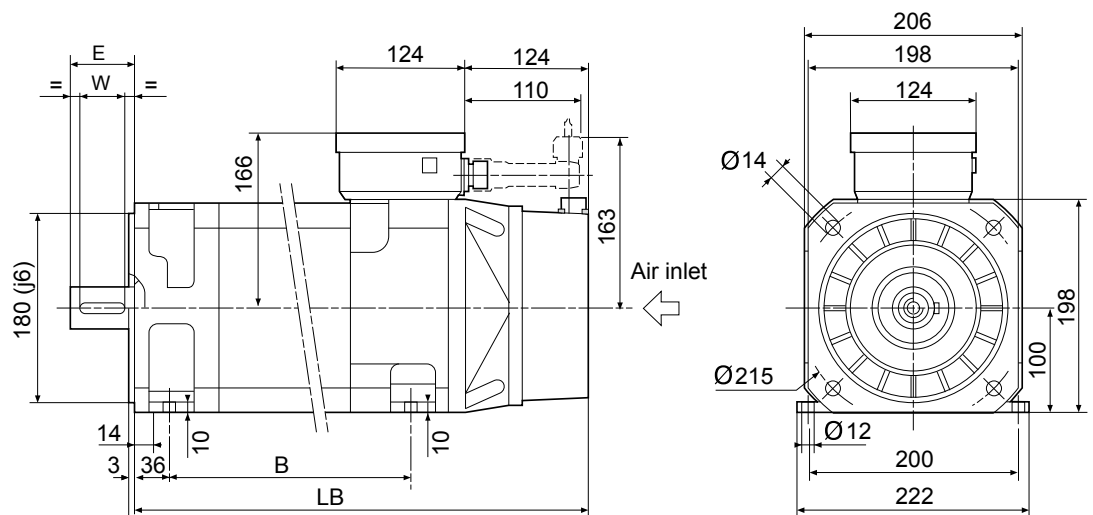

Dimensions in mm

# NUM Motors

NUM Motors BHX, BPX, BPH, BPG, BHL, AMS, IM Spindle Motors, AMR

NUM Motors AMS and IM  
Outline Drawings AMS Motors

## AMS 132 Motor

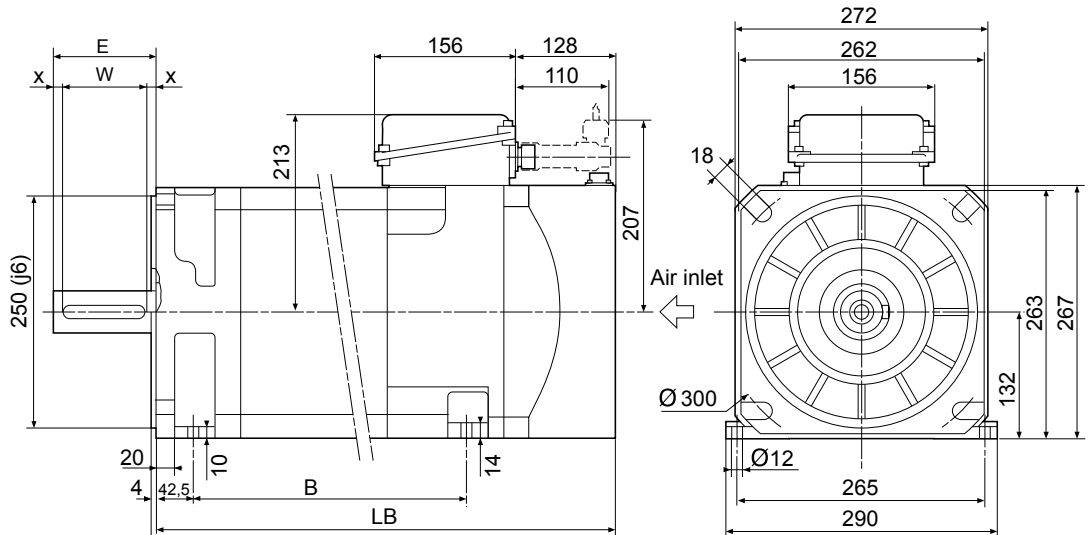

Dimensions in mm

## AMS 160 Motor

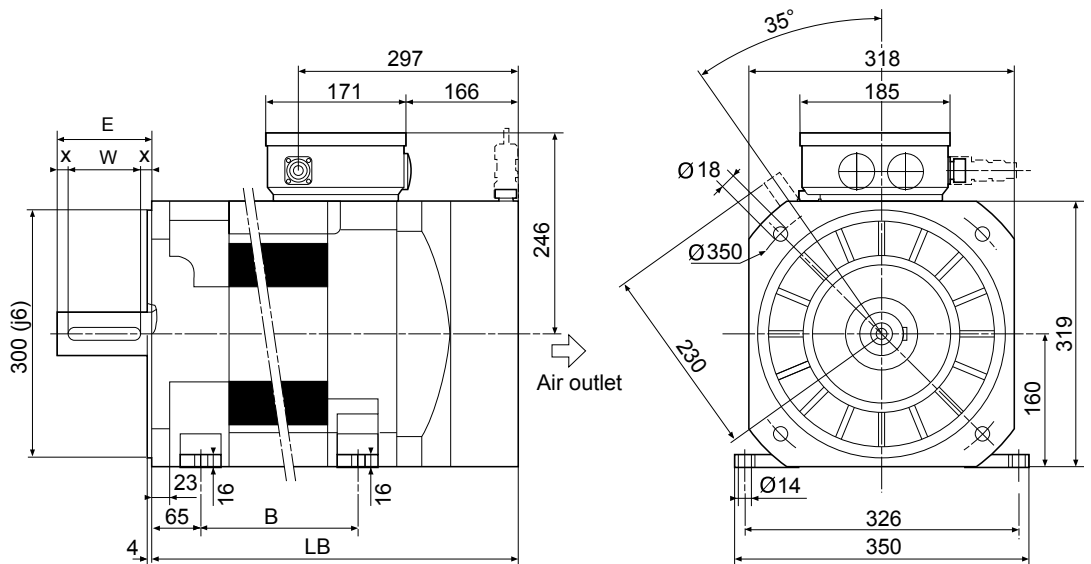

Dimensions in mm



# NUM Motors

NUM Motors BHX, BPX, BPH, BPG, BHL, AMS, IM Spindle Motors, AMR

NUM Motors AMS and IM  
Outline Drawings IM Motor

## Outline Drawings IM Motor

### IM 18MK14 Motor

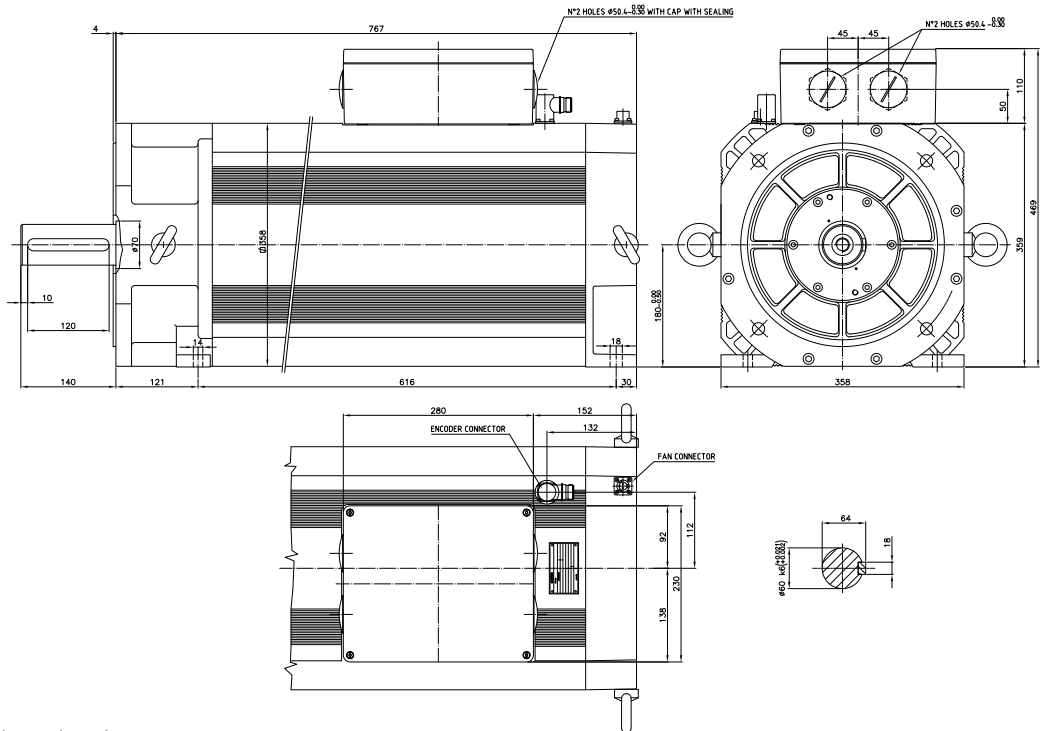

Dimensions in mm

# NUM Motors

NUM Motors BHX, BPX, BPH, BPG, BHL, AMS, IM Spindle Motors, AMR

NUM Motors AMS and IM  
Ordering Codes

## AMS Motors

	AMS	100	S	B	1	Q	22	L	R	0
<b>Series</b>										
<b>Size (100, 132, 160)</b>										
<b>Length</b>										
<b>Winding type</b>										
<b>Fixed value</b>					1					
<b>Sensor type</b>										
- High resolution multi-turn encoder						P				
- High resolution single-turn encoder						Q				
<b>Fixed value</b>							22			
<b>Shaft extension</b>										
- Smooth								L		
- Keyed								C		
<b>Vibration class</b>										
- Class R									R	
- Class S									S	
<b>Degree of protection (shaft extension/frame/fan) and radial load</b>										
- IP 54/65/54 with standard admitted radial load										0
- IP 65/65/54 with standard admitted radial load										1
- IP 54/65/54 with high admitted radial load (just for size 132 and 160)										2
- IP 65/65/54 with high admitted radial load (just for size 132 and 160)										3

## IM Motor

	IM	18	M	K14	C	Q	22	L	R	0
<b>Series</b>										
<b>Size</b>										
<b>Length</b>										
<b>Winding type</b>										
<b>Fixed value</b>										
<b>Sensor type</b>										
- High resolution multi-turn encoder						P				
- High resolution single-turn encoder						Q				
<b>Fixed value</b>										
<b>Shaft extension</b>										
- Smooth								L		
- Keyed								C		
<b>Vibration class</b>										
- Class R									R	
- Class S									S	
<b>Degree of protection (shaft extension)</b>										
- IP 54										0
- IP 65										1

5

# NUM Motors

NUM Motors BHX, BPX, BPH, BPG, BHL, AMS, IM Spindle Motors, AMR

NUM Motors AMS and IM  
Accessories, Accessory Descriptions

## AMS connectors, cables and cable assemblies

	Connectors		High-Strength Cable gland	Cables			Cable assemblies*									
	Sensor	Fan		Power	Sensor	Fan	Sensor	Fan**								
AMS100SB1...	CONN125D00	CONN113D00	BMHQPRE2	PC060BH00	SC007SH00	NC010NL00	SC007SH1wMnnnn	NC010NL70Mnnnn								
AMS100MB1...									PC100BH00							
AMS100GB1...				PC215BH00												
AMS100SD1...									PC100BH00							
AMS100MD1...										PC215BH00						
AMS100GD1...											PC215BH00					
AMS132SA1...												PC215BH00				
AMS132SC1...													PC215BH00			
AMS132SE1...														PC215BH00		
AMS132MA1...															PC215BH00	
AMS132MC1...																PC215BH00
AMS132ME1...																
AMS132LA1...			PC215BH00													
AMS132LE1...				PC215BH00												
AMS132SF1...									PC215BH00							
AMS132SG1...										PC215BH00						
AMS132SH1...											PC215BH00					
AMS132MF1...												PC215BH00				
AMS132MG1...													PC215BH00			
AMS132MH1...														PC215BH00		
AMS132LF1...															PC215BH00	
AMS132LI1...																PC215BH00
AMS132LH1...			PC215BH00													
AMS160MA1...				PC215BH00												
AMS160MB1...									PC215BH00							
AMS160MC1...										PC215BH00						
AMS160LA1...											PC215BH00					
AMS160LB1...												PC215BH00				
AMS160LC1...	PC215BH00															

\* Note for the cable assemblies see below

\*\* Only the motor connector is present and assembled

	Connectors		High-Strength Cable gland	Cables			Cable assemblies*	
	Sensor	Fan		Power	Sensor	Fan	Sensor	Fan
IM18MK14...	AMOC0N002D	CONN114D00	2 x M50	2 x (4x25mm <sup>2</sup> )	SC007SH00	2x1mm <sup>2</sup>	SC007SH2wMnnnn	—

\* Note for the cable assemblies see below

w: sensor connector on drive side  
w = 0 Without connector  
w = 3 with connector AEOCON012

w = 4 with connector AEOCON012 reversed  
nnnn cable length in 0.1m  
nnnn = 0105 = 10.5m

## Accessory Descriptions

AMOC0N002D	Encoder connector *
CONN125D00	Encoder connector *
CONN113D00	Fan connector *
CONN114D00	Fan connector *
BMHQPRE2	High-Strength Cable gland Pg 21 *
BMHQPRE3	High-Strength Cable gland Pg 29 *
PC060BH00	High performance power cable ([3+T]x6mm <sup>2</sup> + (2x1.5mm <sup>2</sup> )) *
PC100BH00	High performance power cable ([3+T]x10mm <sup>2</sup> + (2x1.5mm <sup>2</sup> )) *
PC215BH00	High performance power cable ([3+T]xAWG04 + (2x1.5mm <sup>2</sup> )) *
SC007SH00	High performance sensor cable (3x(2x0.14)+4x0.14+2x0.50) *
NC010NL00	Standard cable ([3+T]x1.5mm <sup>2</sup> ) *

AMOTRF001 | Auto-transformer for fan needed in case of 480 Vac mains

\* See association table on top

# NUM Motors

NUM Motors BHX, BPX, BPH, BPG, BHL, AMS, IM Spindle Motors, AMR

Auto-Transformer

Technical Characteristics, Outline Drawings

## Technical Characteristics

	<b>AMOTRF001</b>
Rated Power	500 VA
Input Voltage	400Vac / 480Vac 3 phases
Frequency	50/60 Hz
Protection Class as per EN60529	IP00
Weight	2.8 kg

## Outline Drawings

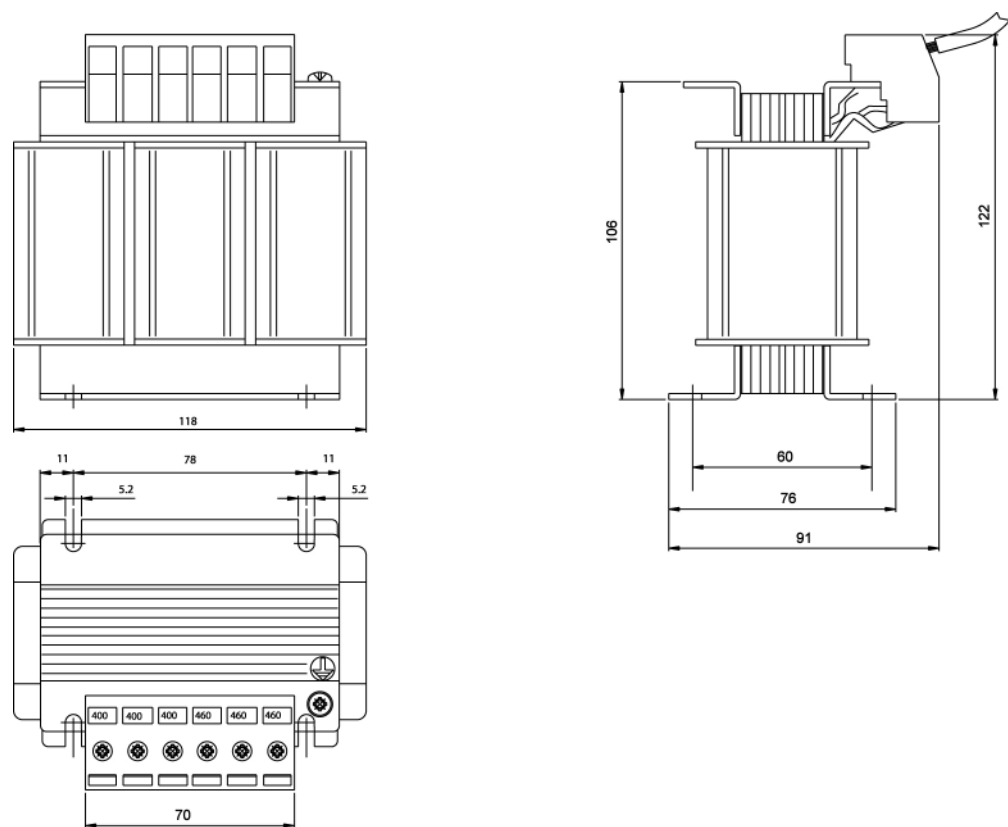

Dimensions in mm

# NUM Motors

---

NUM Motors BHX, BPX, BPH, BPG, BHL, AMS, IM Spindle Motors, AMR

Special and Built-In Motors  
General Information

---

## General Information

As well as the standard product described above, NUM produces special and built-in (Motorspindle) motors, designed in order to fit the customer's needs.

Please contact our sale offices for information about special and built-in motors.



Motorspindle®: stator elements, synchronous and asynchronous technology, for integration in electro spindles

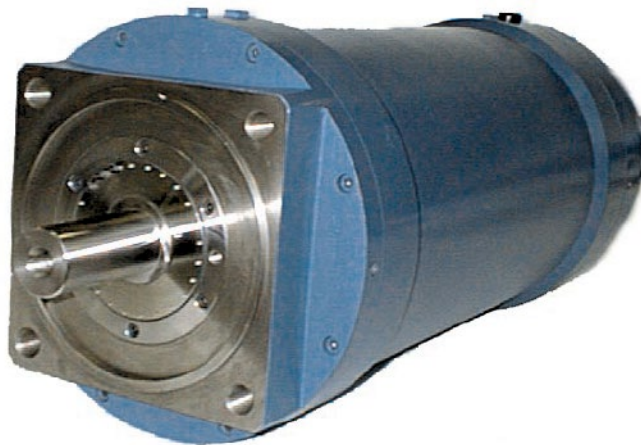

AMR hybrid cooling motor (liquid plus air cooling from shaft)

# 6 NUM Servo Drives

## NUM Servo Drives

### Table of contents

	Page
<b>General Information</b>	<b>111</b>
Introduction	111
Common Characteristics	111
<b>Power Supplies</b>	<b>112</b>
Introduction	112
Technical Characteristics	112
Outline Drawings	113
Ordering Codes	114
Accessories	114
<b>NUMDrive C</b>	<b>115</b>
Introduction	115
Interoperability and Functions	116
Interoperability and Functions	117
Technical Characteristics	118
Outline Drawings	119
Ordering Codes	120
Ordering Codes	121
Accessories	122
<b>Accessories</b>	<b>123</b>
Capacitor Module: Technical Characteristics, Outline Drawing	123
Filters: Technical Characteristics	124
Filters: Outline Drawings	125
Line Chokes: Technical Characteristics	126
Line Chokes: Outline Drawings	127
Braking Resistors: Technical Characteristics, Outline Drawings	128
Brake resistance: Outline Drawings	129
Mechanical Adapter: Outline Drawings	130
Mechanical Adapter: Outline Drawings	131



# NUM Servo Drives

## NUM Servo Drives

### General Information

#### Introduction

#### Common Characteristics

### Introduction

The NUMDrive C servo drives with their modern design are the ideal counterpart to the powerful Flexium CNC System. Modular in design, compact in their dimensions and with a low power consumption, they correspond ideally to the needs of modern systems.

See the following schematic for a generic system layout.

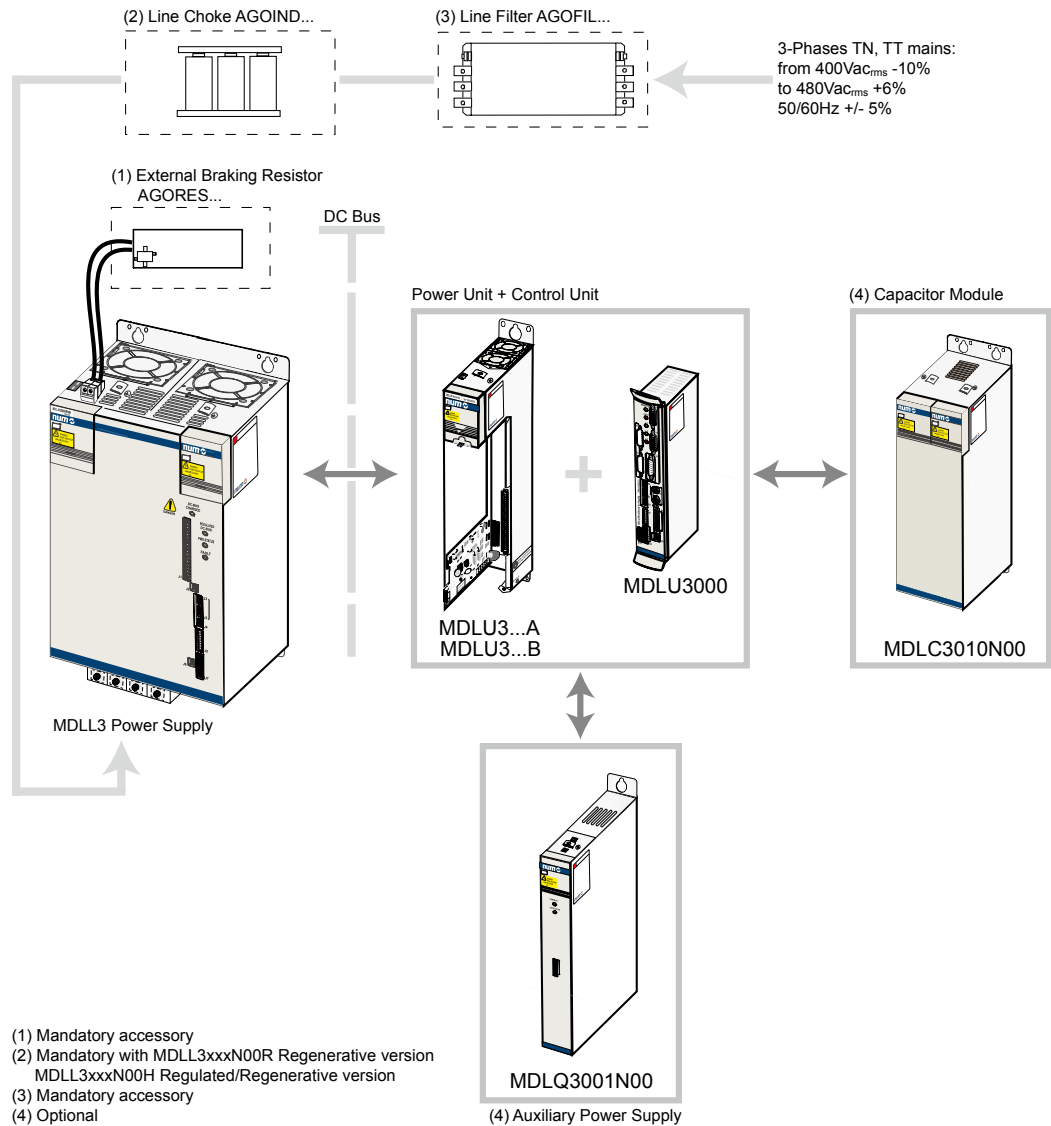

6

### Common characteristics

All the NUM servo drives have got the following characteristics:

Environment storage conditions:	
Temperature range	- 40 to + 80 °C
Relative humidity	max. 75% without condensation
Environment working conditions:	
Temperature range	0 to 40 °C without derating, max 60 °C with derating
Relative humidity	max. 75% without condensation
Vibration to EN60068-2-6	max. deflection 75 µm, frequency 10 to 58 Hz
Altitude	0 to 1000 m without derating, max 3000 m with derating



# NUM Servo Drives

## NUM Servo Drives

### Power Supplies

#### Introduction

#### Technical Characteristics

### Introduction

MDLL power supplies are designed to be used in conjunction with NUMDrive C. MDLLs supply the voltage via DC bus and the control voltage (auxiliary voltage).

MDLLs are available in various power ratings and with dissipation of the braking energy by external resistor or with reinjection into the mains.

MDLQ is an auxiliary power supply used whenever the available built-in auxiliary power of the MDLL isn't sufficient (high number of drives). Refer to the installation manual for more information.

### Technical Characteristics

MDLL3 Power Supplies		MDLL3015 N00AN01	MDLL3030 N00AN01	MDLL3025 N00RN01	MDLL3050 N00RN01	MDLL3025 N00HN01	MDLL3050 N00HN01	MDLL3120 N00HN01	
Rated output power (S1)	kW	15	30	25	50	25	50	120	
S3 duty cycle power(4s ON - 6s OFF)	kW	40	45	50	97	50	97	150	
Peak power	kW	50	50	50	97	50	97	190	
Maximum continuous braking power	kW	15	30	25	50	25	50	120	
Peak braking power	kW	51	61	61	120	61	120	200	
Rated input voltage	V	400VACrms-10% to 480VACrms+6% 50/60Hz ±5% 3 phases							
Rated input current	Arms	31 (cosφ 0.7)	62 (cosφ 0.7)	50 (cosφ 0.7)	100 (cosφ 0.7)	36 (cosφ 1)	72 (cosφ 1)	173 (cosφ 1)	
DC Bus voltage at rated power	Vdc	540Vdc with 400Vrms input, 650Vdc with 480Vrms input				Configurable DC Bus voltage: 600, 650, 700 Vdc			
Dissipation of Braking Energy		On braking resistor			Reinjection in mains				
Auxiliary Rated Power	W	230			180				
Protection degree (EN60529)		IP20			IP00				
Overall Dimensions (WxHxD)	mm	100 x 355 x 206			200 x 355 x 206				300 x 355 x 206 ***
Weight	Kg	5.5			11.5				19
Line filter		AGOFIL024A	AGOFIL025A	AGOFIL026 + HPPM166	AGOFIL026 + HPPM166	AGOFIL026 + HPPM166	AGOFIL026 + HPPM166	AGOFIL027 + HPPM166	
Line choke		---	---	AGOIND006	AGOIND007	AGOIND001	AGOIND002	AGOIND009	
Auxiliary power supply line filter		AGOFIL001S							
External Braking Resistor *		AGORES008	AGORES009	AGORES008 or AGORES009				AGORES010	

MDLQ3 Power Supply		MDLQ3001N00
Auxiliary Rated Power	W	250
Input Voltage	V	400VACrms-10% to 480VACrms+6% 50/60Hz ±5% 2 phases
Protection degree (EN60529)		IP20
Overall Dimensions (WxHxD)	mm	50 x 355 x 206
Weight	Kg	2.8
Line filter		AGOFIL001S
Mechanical Adapter **		AEOADA007

\* = At least one external braking resistor is mandatory.

\*\* = Required in a system with NUM HP Drives.

\*\*\* = Add 310mm to 355 due to fan dimensions.

# NUM Servo Drives

## NUM Servo Drives

### Power Supplies Outline Drawings

#### Outline Drawings

MDLQ3001... Size 1

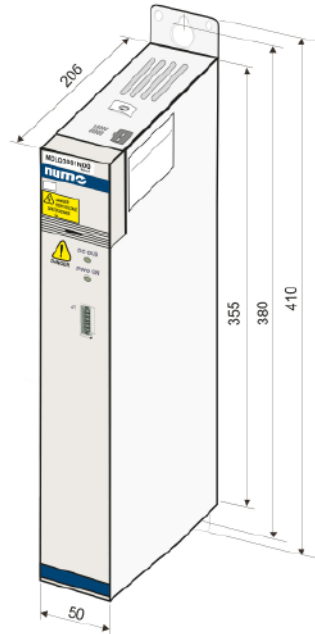

MDLL3015..., MDLL3030... Size 2

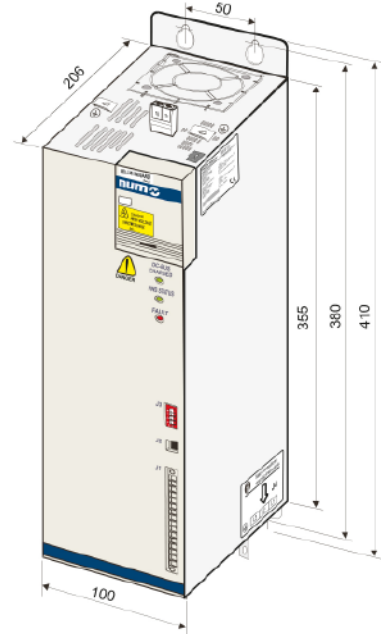

MDLL3025... and MDLL3050... Size 4

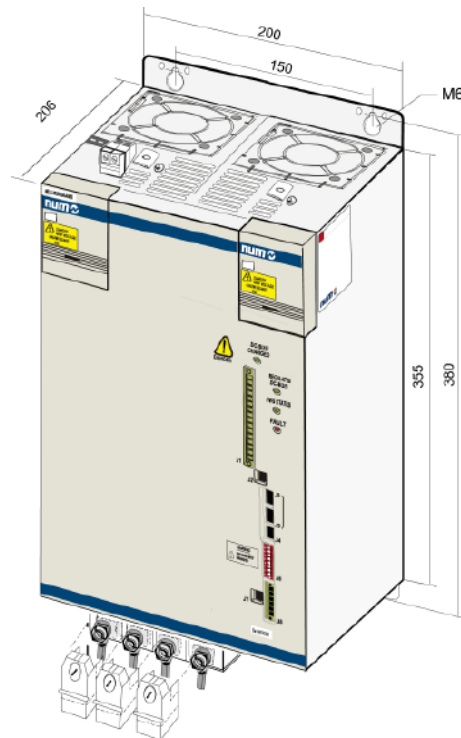

MDLL3120... Size 6

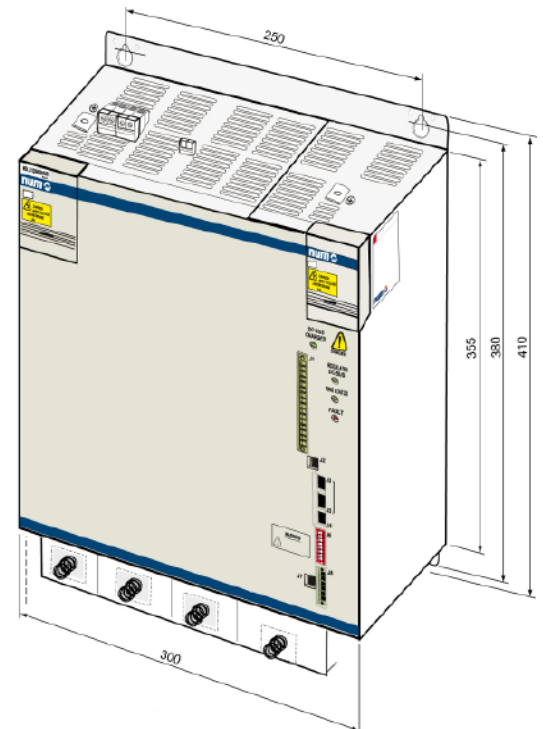

**Note:**

For installation remember to take the cable and connector dimensions into account, adding approximately 75 mm to the depth ( $206+75\text{mm} = 281$ ).

# NUM Servo Drives

## NUM Servo Drives

Power Supplies

Ordering Codes

Accessories

## Power Supplies

	<b>MDLL</b>	<b>3</b>	<b>015</b>	<b>N</b>	<b>00</b>	<b>A</b>	<b>N</b>	<b>0</b>	<b>I</b>
<b>Series</b>									
<b>Evolution index</b>									
<b>Rated power</b>									
- Size 2: Pn 15kW			015						
- Size 2: Pn 30kW			030						
- Size 4: Pn 25kW			025						
- Size 4: Pn 50kW			050						
- Size 6: Pn 120kW <sup>(5)</sup>			120						
<b>Mains supply</b>									
- From 400Vac -10% to 480Vac +6% 50/60Hz +/-5%, 3 phases				N					
<b>Options</b>									
- None					00				
<b>Type</b>									
- Passive power supply <sup>(1) (2)</sup>						A			
- Regenerative power supply <sup>(1) (3) (4)</sup>						R			
- Regulated DCBus power supply <sup>(1) (3) (4)</sup>						H			
<b>Version</b>									
- Standard NUM							N		
<b>Standard NUM</b>								0	
<b>Heat-sink position</b>									
- Internal heat-sink									I

<sup>(1)</sup> An external braking resistor must be always used

<sup>(2)</sup> Not available on Pn 25kW, Pn 50kW and Pn 120kW sizes

<sup>(3)</sup> Not available on Pn 15kW and Pn 30kW sizes

<sup>(4)</sup> An external line choke must be always used

<sup>(5)</sup> An external AGOFAN001 and AEOKIT003 must be always taken in account

# NUM Servo Drives

## NUM Servo Drives

### NUMDrive C

#### Introduction

#### Introduction

The NUMDrive C servo drives with their modern design are the ideal counterpart to the powerful Flexium CNC.

One distinguishing feature of the NUMDrive C is its **high power density**. The servo drives offer an enormous amount of computing and drive power within a very small space and thus have one of the highest power/volume ratios available.

The **wide range** of power units and scalable control units, available in **Mono-Axis or Bi-Axes** versions, enables the technically best and most economical solution to be implemented. For the maximum contour precision, speeds and cost-effectiveness, the NUMDrive C servo drives can be exactly adapted to the particular machine and application.

The **modularity** of the NUMDrive C enables perfect adaptation to the system with stringent cost control at the same time. The common power and auxiliary power supply units enable the distribution and use of the system energy, which reduces the power consumption. Per system only one filter and one braking resistor are required in each case. More than one Braking resistor could be used in extreme applications - see page 128.

A servo drive consists of the power unit and a control unit that should be ordered separately except in the case of CANopen application.

The high-performance HP control units were developed for use with sophisticated and complex applications in precision machine tools. The position control loop is closed with a very high bandwidth, achieving exceptional precision and speed at the mechanical interface of the machine (motor axis, linear motor). NUMDrive C accepts almost all measuring systems and can control a broad range of motors (servo, torque, linear, asynchronous motors) from NUM or other manufacturers. This ensures that a solution can be selected that is optimal from the technical and economic perspectives. The basic-performance BP control units are suited to systems and precision machine tools of medium complexity as well as to cost-effective solutions.

For auxiliary axes or auxiliary spindles control, the NUMDrive C with CANopen is the most suitable solution. The CAN interface complies with a subset of the Device Profile DS402. The EDS (Electronic Data Sheet) files are available for the application of Mono-Axis and Bi-Axes versions.

The small installation depth and scalable width (a multiple of 50 mm) simplify the cabinet layout.

The NUMDrive C Mono-Axis and Bi-Axes offer as standard the NUM-STO (Safe Torque Off) module certified SIL 2 according to IEC 61508. This allows the realisation of E-STOP functions category 0 and 1 according to EN60204-1.

For the NUMDrive C Mono-Axis, the SAM Num safety module certified SIL 2 according to IEC 61508 is available as an option, which offers various integrated safety functions: STO Safe Torque Off, SLS Safely Limited Speed, SOS Safe Operational Stop, SS1 Safe Stop 1, SS2 Safe Stop 2, Interlock gate relay, Safe outputs.

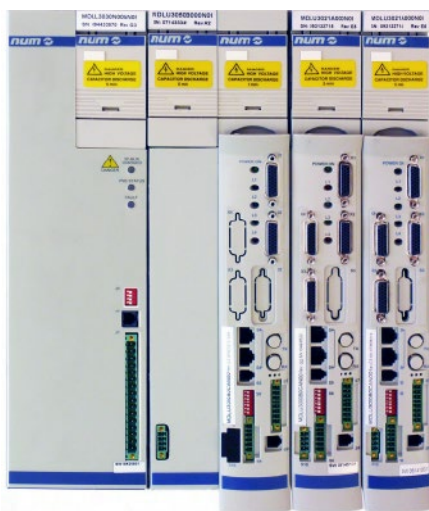

# NUM Servo Drives

## NUM Servo Drives

### NUMDrive C with DISC NT bus Interoperability and Functions

#### Interoperability and Functions

		Bi-Axes BP	Mono-Axis HP	Bi-Axes HP
Interface	High speed digital bus DISC NT	●	●	●
Control Performance	High performance control loops	-	●	●
Compatible Motors	Closed loop: synchronous rotary motors *	●	●	●
	Closed loop: synchronous torque and linear motors	-	●	●
	Closed loop: asynchronous motors	●	●	●
	Open loop: asynchronous motors	●	●	●
Compatible Motor Sensors	Hyperface encoder	●	●	●
	TTL encoder	●	●	●
	EnDat 2.1 & EnDat 2.2 encoder	●	●	●
	1 Vpp toothed wheel / encoder	●	●	●
	Sensor less	●	●	●
Compatible Direct Measure Sensors	Hyperface encoder / linear scale	-	●	●
	TTL encoder / linear scale	-	●	●
	EnDat 2.1 & EnDat 2.2 encoder / linear scale	-	●	●
	SSI encoder / linear scale	-	●	●
	Hall sensors	-	●	●
	1 Vpp encoder / linear scale (also with coded references)	-	●	●
Special Functions	Spindle operation for synchronous and asynchronous motors	●	●	●
	Synchronous motor phasing without movement **	●	●	●
	Spindle-Axis commutation	●	●	●
	Star/Delta commutation on the fly (for asynchronous motor)	-	●	●
	Rotary axis with mechanical ratio not 2 <sup>x</sup>	●	●	●
	Tandem Function ***	-	●	●
	- Anti-Backlash			
	- Torque Synchronisation			
	Coherence control between motor and direct measure sensor	-	●	●
	Various active damping functions (for resonance suppression)	-	●	●
	Various freely settable filters	●	●	●
	Multi spindle handling	-	●	-
	Certified Safety Functions compliant with EN 61800-5-2 up to SIL 3	NUM-STO module **** with Safe Torque Off	●	●
SAM-Num module **** with		-	○	-
- STO Safe Torque Off				
- SLS Safely Limited Speed				
- SOS Safe Operational Stop				
- SS1 Safe Stop 1				
- SS2 Safe Stop 2				
- Interlock gate relay				
- Safe outputs				

\* Having a compatible position sensor

\*\* Required with incremental encoders

\*\*\* Not allowed for asynchronous motors in open loop mode

\*\*\*\* SAM-Num module replace NUM-STO

● basic

○ optional

- unavailable

# NUM Servo Drives

## NUM Servo Drives

### NUMDrive C with CANopen Interoperability and Functions

#### Interoperability and Functions

		Bi-Axes BP	Mono-Axis HP
Interface	CANopen	●	●
Control Performance	High performance control loops	-	●
Compatible Motors	Closed loop: synchronous rotary motors *	●	●
	Closed loop: synchronous torque and linear motors	-	●
	Closed loop: asynchronous motors	●	●
	Open loop: asynchronous motors	●	●
Compatible Motor Sensors	Hyperface encoder	●	●
	TTL encoder	●	●
	EnDat 2.1 & EnDat 2.2 encoder	●	●
	1 Vpp toothed wheel / encoder	●	●
Compatible Direct Measure Sensors	Sensor less	●	●
	Hyperface encoder / linear scale	-	●
	TTL encoder / linear scale	-	●
	EnDat 2.1 & EnDat 2.2 encoder / linear scale	-	●
	SSI encoder / linear scale	-	●
	Hall sensors	-	●
Special Functions	1 Vpp encoder / linear scale (also with coded references)	-	●
	Spindle operation for synchronous and asynchronous motors	●	●
	Synchronous motor phasing without movement **	●	●
	Spindle-Axis commutation	●	●
	Star/Delta commutation on the fly (for asynchronous motor)	-	-
	Rotary axis with mechanical ratio not 2 <sup>x</sup>	●	●
	Coherence control between motor and direct measure sensor	-	●
	Various active dumping functions (for resonance suppression)	-	●
	Various freely settable filters	●	●
	Multi spindle handling	-	-
Device profile	Speed	●	●
	Positioning	●	●
	Homing	●	●
Certified Safety Functions compliant with EN 61800-5-2 up to SIL 3	NUM-STO module with Safe Torque Off	○	○

\* Having a compatible position sensor  
 \*\* Required with incremental encoders

● basic  
 ○ optional  
 - unavailable

# NUM Servo Drives

## NUM Servo Drives

### NUMDrive C

#### Technical Characteristics

#### Technical Characteristics

Mono-Axis		MDLU3014A...		MDLU3021A...		MDLU3034A...	
Switching Frequency	kHz	5	10	5	10	5	10
Rated Current (S1)	Arms	8.9	6	13	8	13	8
Maximum Current	Arms	10		15		24	
Auxiliary power consumption <sup>1</sup>	W (+/- 5%)	21					
Protection degree (EN60529) <sup>2</sup>		IP20					
Overall Dimensions (WxHxD)	mm	50 x 355 x 206					
Weight <sup>3</sup>	kg	3					
Drive Side Motor Connector		AEOCON009					
Drive Side Sensor Connector		AEOCON012					

Mono-Axis		MDLU3050A...		MDLU3075A...			
Switching Frequency	kHz	5	10	5	10		
Rated Current (S1)	Arms	28	18	34	23		
Maximum Current	Arms	35		53			
Auxiliary power consumption <sup>1</sup>	W (+/- 5%)	25					
Protection degree (EN60529) <sup>2</sup>		IP20					
Overall Dimensions (WxHxD)	mm	100 x 355 x 206					
Weight <sup>3</sup>	kg	5.9					
Drive Side Motor Connector		AEOCON013					
Drive Side Sensor Connector		AEOCON012					

Mono-Axis		MDLU3130A...		MDLU3200A...		MDLU3400A...	
Switching Frequency	kHz	5	10	5	10	5	10
Rated Current (S1)	Arms	60	42	100	70	200	130
Maximum Current	Arms	92		141		282	
Auxiliary power consumption <sup>1</sup>	W (+/- 5%)	45					
Protection degree (EN60529) <sup>2</sup>		IP00					
Overall Dimensions (WxHxD)	mm	200 x 355 x 206				300 x 355 x 206 <sup>4</sup>	
Weight <sup>3</sup>	kg	11					
Drive Side Motor Connector		-					
Drive Side Sensor Connector		AEOCON012					

Bi-Axes		MDLU3014B...		MDLU3021B...		MDLU3050B...	
Switching Frequency	kHz	5	10	5	10	5	10
Rated Current (S1)	Arms	6.3 + 6.3	4.2 + 4.2	6.3 + 6.3	4.2 + 4.2	20 + 20	13 + 13
Maximum Current	Arms	10 + 10		15 + 15		35 + 35	
Auxiliary power consumption <sup>1</sup>	W (+/- 5%)	24					
Protection degree (EN60529) <sup>2</sup>		IP20					
Overall Dimensions (WxHxD)	mm	50 x 355 x 206		50 x 355 x 206		100 x 355 x 206	
Weight <sup>3</sup>	kg	3					
Drive Side Motor Connector		AEOCON009					
Drive Side Sensor Connector		AEOCON012					

<sup>1</sup> Internal consumption with Control Unit installed, without considering sensor power supply.  
Add 1W for each connected sensor (motor or direct)

<sup>2</sup> With Control Unit installed

<sup>3</sup> Power Unit + Control Unit

<sup>4</sup> Add 310mm to 355 due to fan dimensions.

# NUM Servo Drives

## NUM Servo Drives

### NUMDrive C

### Outline Drawings

#### Outline Drawings

MDLU3014..., MDLU3021..., MDLU3034... Size 1

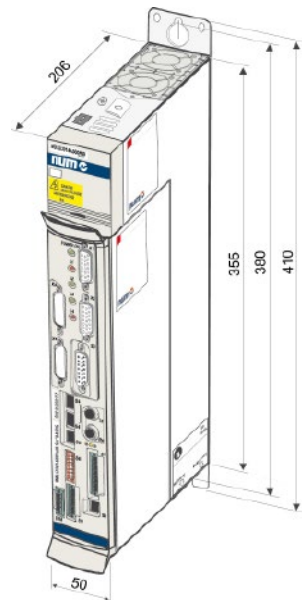

MDLU3050..., MDLU3075... Size 2

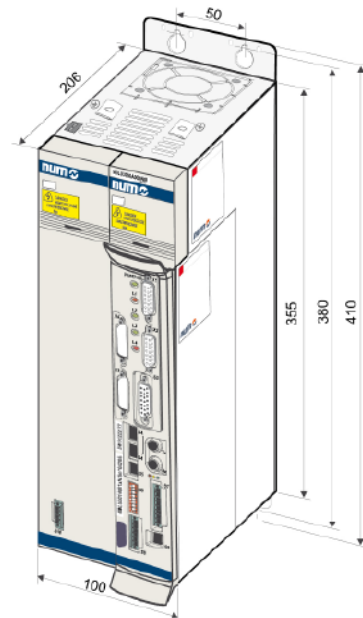

MDLU3130..., MDLU3200... Size 4

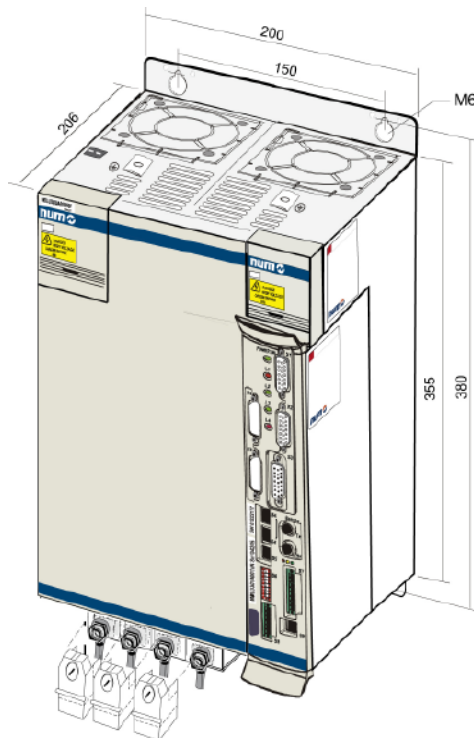

MDLU3400... Size 6

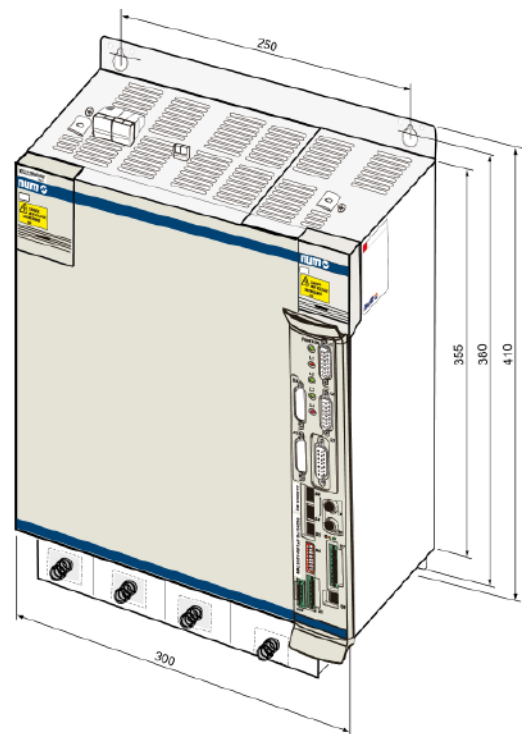



# NUM Servo Drives

## NUM Servo Drives

### NUMDrive C

### Ordering Codes

#### Ordering Codes

<b>Control Units</b>	<b>MDLU</b>	<b>3</b>	<b>000</b>	<b>A</b>	<b>0</b>	<b>C</b>	<b>A</b>	<b>N</b>	<b>0</b>	<b>0</b>
<b>Series</b>										
<b>Evolution index</b>										
<b>Control Unit</b>										
<b>Axis number</b>										
- Mono-Axis				A						
- Bi-Axes				B						
<b>Communication</b>										
- DISC NT interface					0					
<b>Version</b>										
- Basic Performance (1)						B				
- High Performance						C				
<b>Safety</b>										
- Certified NUM-STO (Safe Torque Off) module according to EN 61800-5-2 up to SIL 3							E			
- Stop function Category 0 (2)							A			
- Certified SAM-Num Safety module according to EN 61800-5-2 SIL 2 (3)							S			
<b>Standard NUM</b>								N		
<b>Fixed value</b>									0	
<b>Fixed value</b>										0

<sup>(1)</sup> Not available with Mono-Axis version

<sup>(2)</sup> Not certified

<sup>(3)</sup> Not available with Bi-Axes version

<b>Power Units</b>	<b>MDLU</b>	<b>3</b>	<b>014</b>	<b>A</b>	<b>000</b>	<b>N</b>	<b>0</b>	<b>I</b>
<b>Series</b>								
<b>Evolution index</b>								
<b>Rated Current</b>								
<b>Mono-Axis</b>								
- Size 1: In 8.9Arms, Ipeak 10Arms			014					
- Size 1: In 13Arms, Ipeak 15Arms			021					
- Size 1: In 13Arms, Ipeak 24Arms			034					
- Size 2: In 28Arms, Ipeak 35Arms			050					
- Size 2: In 34Arms, Ipeak 53Arms			075					
- Size 4: In 60Arms, Ipeak 92Arms			130					
- Size 4: In 100Arms, Ipeak 141Arms			200					
- Size 6: In 200Arms, Ipeak 282Arms (1)			400					
<b>Bi-Axes</b>								
- Size 1: In 6.3+6.3Arms, Ipeak 10+10Arms			014					
- Size 1: In 6.3+6.3Arms, Ipeak 15+15Arms			021					
- Size 2: In 20+20Arms, Ipeak 35+35Arms			050					
<b>Axis number</b>								
- Mono-Axis				A				
- Bi-Axes				B				
<b>Power unit</b>								
<b>Mono-Axis</b>								
- For all Control Unit types					000			
<b>Bi-Axes</b>								
- For Control Unit with NUM-STO module					00E			
- For Control Unit without NUM-STO module					000			
<b>Standard NUM</b>							N	
<b>Fixed value</b>								0
<b>Heat-sink position</b>								
- Internal heat-sink								I

<sup>(1)</sup> An external AGOFAN001 and AEOKIT004 must be always taken in account

# NUM Servo Drives

## NUM Servo Drives

### NUMDrive C CANopen Ordering Codes

#### Ordering Codes

	MDLU	3	014	A	C	C	A	N	0	I
<b>Series</b>										
<b>Evolution index</b>										
<b>Rated Power</b>										
<b>Mono-Axis</b>										
- Size 1: In 8.9Arms, Ipeak 10Arms			014							
- Size 1: In 13Arms, Ipeak 15Arms			021							
- Size 1: In 13Arms, Ipeak 24Arms			034							
- Size 2: In 28Arms, Ipeak 35Arms			050							
- Size 2: In 34Arms, Ipeak 53Arms			075							
- Size 4: In 60Arms, Ipeak 92Arms			130							
- Size 4: In 100Arms, Ipeak 141Arms			200							
- Size 6: In 200Arms, Ipeak 282Arms <sup>(1)</sup>			400							
<b>Bi-Axes</b>										
- Size 1: In 6.3+6.3Arms, Ipeak 10+10Arms			014	A						
- Size 1: In 6.3+6.3Arms, Ipeak 15+15Arms			021	B						
- Size 2: In 20+20Arms, Ipeak 35+35Arms			050							
<b>Axis number</b>										
- Mono-Axis				A						
- Bi-Axes				B						
<b>Communication</b>										
- CANopen interface					C					
<b>Version</b>										
- Basic Performance <sup>(2)</sup>						B				
- High Performance <sup>(3)</sup>						C				
<b>Safety</b>										
- Stop function category 0 <sup>(4)</sup>							A			
- Certified NUM-STO (Safe Torque Off) module according to EN 61800-5-2 up to SIL 3							E			
<b>Standard NUM</b>								N		
<b>Fixed value</b>									0	
<b>Heat-sink position</b>										
- Internal heat-sink										I

<sup>(1)</sup> An external AGOFAN001 and AEOKIT004 must be always taken in account

<sup>(2)</sup> Not available with Mono-Axis version

<sup>(3)</sup> Not available with Bi-Axes version

<sup>(4)</sup> Not certified

# NUM Servo Drives

## NUM Servo Drives

### NUMDrive C Accessories

#### Accessories

AEOCON009	Drive side motor and brake connector *
AEOCON013	Drive side motor and brake connector *
AEOCON012	Drive side sensor connector. This connector is used for the motor encoder and the direct measure sensor
AEOADA006	SAM Adapter x 5 SAM-Num modules
AEOFRU003M001	Cable for SAM Adapter l=1.5m
AEOFRU003M001S	Shielded Cable for SAM Adapter l=1.5m
AEOFRU003M005	Cable for SAM Adapter l=5m
AEOFRU003M010	Cable for SAM Adapter l=10m
AEOFRU005M008	Cable for Link MDLU3/PC
AGOCDT002	MDLU3 SAM-Num Commissioning Tool (CD ROM)
AEOADA009	MDLU-CNC-MDLU Dual Ring adapter
AEOADA010	NUMDrive C NUM-STO daisy chain adapter
AEOADA011	RJ45 NUM-STO cable to terminal adapter
AEOADA012	NUMDrive C CAN bus dual row adapter
AEOADA013	NUMDrive C CANbus terminal resistor
AEOADA014	MDLL3-R/H CAN bus adapter
AEOADA015	DISC NT bus dual rows adapter
AEOKIT004	NUMDrive C PWU 300mm Customer conn. Kit
AGOFAN001	Fan for MDLL3 and NUMDrive C 300mm
AEOFRU014M0001	RJ45 Grey Cable Drive size 1
AEOFRU014M0002	RJ45 Grey Cable Drive size 2
AEOFRU014M0003	RJ45 Grey Cable Drive size 4
AEOFRU014M0004	RJ45 Grey Cable Drive size 6
AEOFRU009M001	STO subD cable l=1.5m
AEOFRU007M001	NUMDrive C CAN - CAN master cable l=1.5m
AEOKIT002	NUMDrive C CAN bus connectors kit

\* See NUMDrive C technical characteristics table on page 118 for association

# NUM Servo Drives

## NUM Servo Drives

### Accessories

#### Capacitor Module: Technical Characteristics, Outline Drawing

#### Technical Characteristics

		<b>MDLC3010N00</b>
Capacitance value	uF	8250
DCBus nominal rate	Vdc	400 to 700
Overall Dimensions (WxHxD)	mm	100 x 355 x 206
Weight	kg	6

#### Outline Drawing

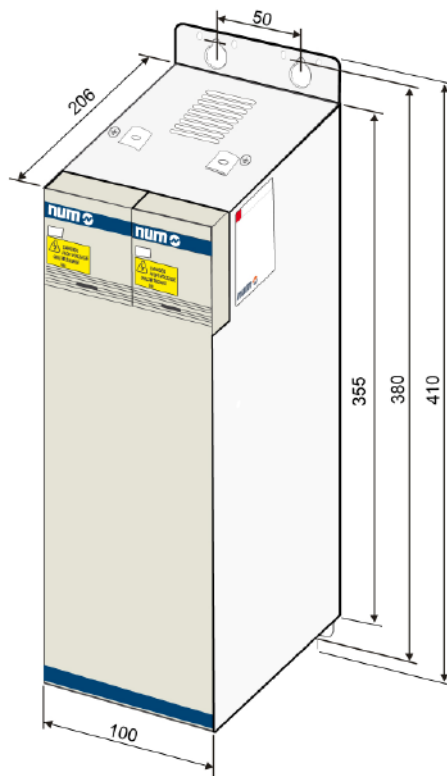

# NUM Servo Drives

## NUM Servo Drives

### Accessories

Filters: Technical Characteristics

### Technical Characteristics

		AGOFIL024A	AGOFIL025A	AGOFIL026	AGOFIL027
Rated voltage	VAC	480			
Line frequency	Hz	50 / 60			
Rated current *	Arms	42	75	100	180
Test voltage (2s)		line to ground 3470VDC line to line 1700VDC			
Leakage current		Normal condition < 3mA Fault condition 260mA (only one phase remaining)			
Terminal block cross section LINE / LOAD	mm <sup>2</sup>	10	16	50	95
Weight	kg	2.8	4.4	4.7	7.5

\* referred to 50°C room temperature

		AGOFIL001S
Rated voltage	VAC	440
Line frequency	Hz	50 / 60
Rated current **	Arms	3
Test voltage (2s)		line to ground 2700VDC line to line 1075VDC
Leakage current		Normal condition < 0.5mA
Terminal connections LINE / LOAD		faston 6.3 x 0.8 mm
Weight	kg	0.3

\*\* referred to 40°C room temperature

		HPPM166
Rated voltage	VAC	440
Line frequency	Hz	50 / 60
Rated current	Arms	20
Capacity		3 x 16.6 microF
Terminal connections		M8 bolt
Weight	kg	1.2

# NUM Servo Drives

## NUM Servo Drives

### Accessories

Filters: Outline Drawings

## Outline Drawings

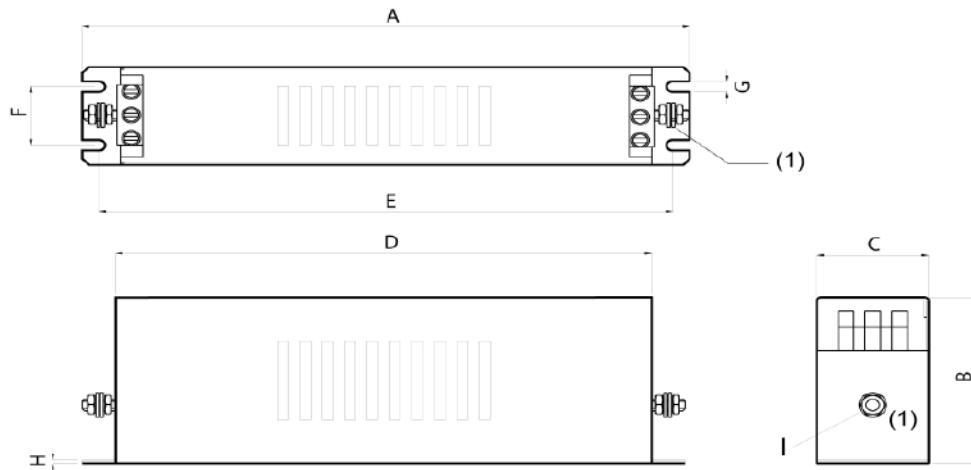

(1) Earth point connections

		A	B	C	D	E	F	G	H	I
<b>AGOFIL024A</b>	mm	310	85	50	280	295	30	5.4	2	M6
<b>AGOFIL025A</b>	mm	270	135	80	240	255	60	6.5	3	M6
<b>AGOFIL026</b>	mm	270	150	90	240	255	65	6.5	3	M10
<b>AGOFIL027</b>	mm	380	170	120	350	365	102	6.5	3	M10

### AGOFIL001S

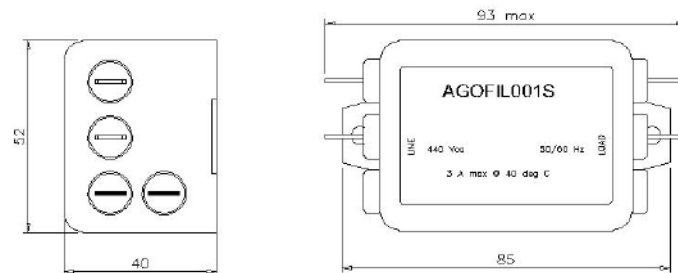

### HPPM166

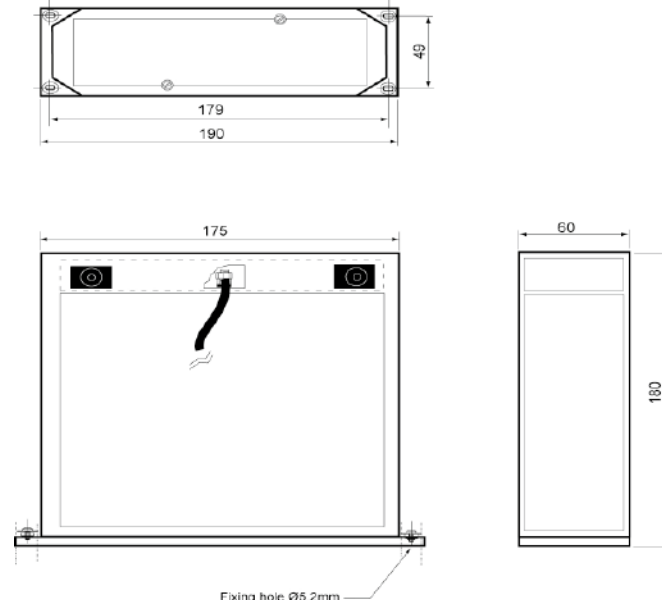

Dimensions in mm

# NUM Servo Drives

## NUM Servo Drives

### Accessories

#### Line Chokes: Technical Characteristics

#### Technical Characteristics

Line choke		AGOIND001	AGOIND002	AGOIND006	AGOIND007	AGOIND009
Rated current	Arms	67	103	60	100	210
Inductance	mH	0.45	0.27	0.5	0.3	0.15
Losses	W	250	350	94	260	300
Degree of protection				IP00		
Terminal cross-section	mm <sup>2</sup>	35	50	16		
Weight	kg	13	18	11	16	56

# NUM Servo Drives

## NUM Servo Drives

### Accessories

### Line Chokes: Outline Drawings

#### Outline Drawings

AGOIND001, AGOIND002

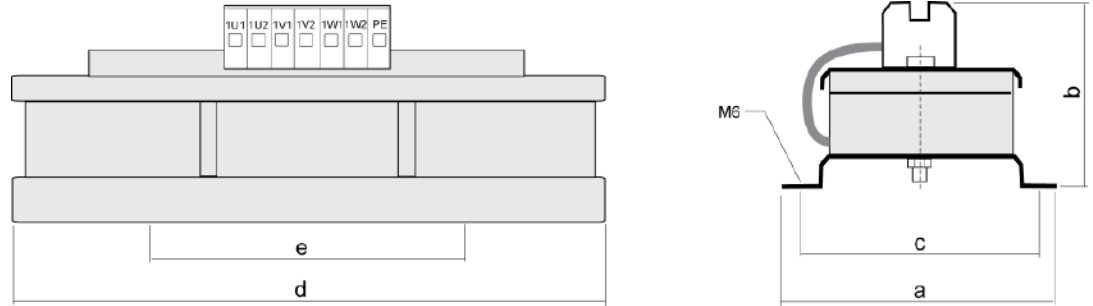

		a	b	c	d	e
<b>AGOIND001</b>	mm	150	230	136	330	175
<b>AGOIND002</b>	mm	150	280	136	330	175

AGOIND006

AGOIND007

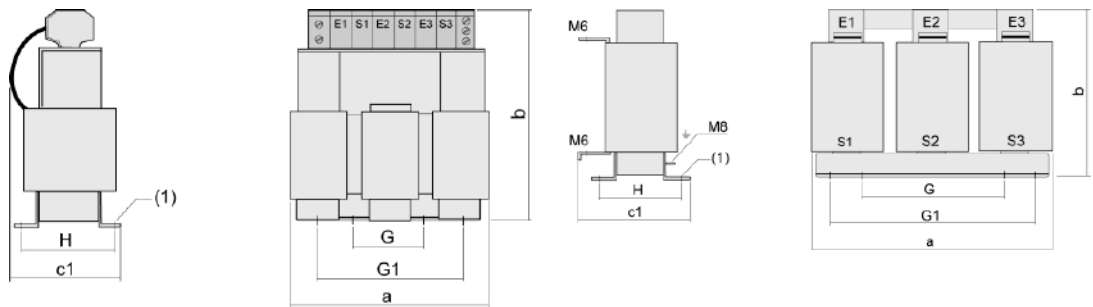

		a	b	c1	G	G1	H	(1)
<b>AGOIND006</b>	mm	180	210	165	85	122	105	8x (Ø 6x12)
<b>AGOIND007</b>	mm	270	210	180	105	181	100	8x (Ø 11x22)

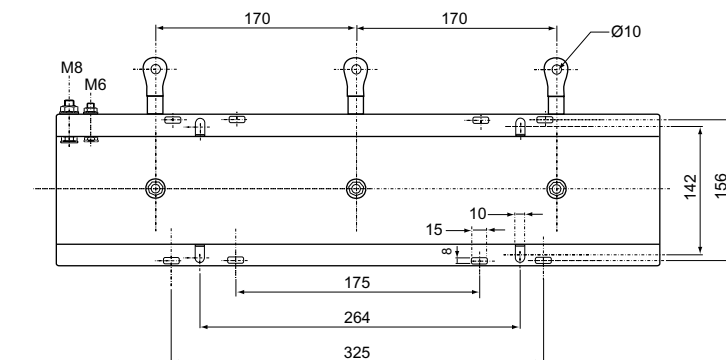
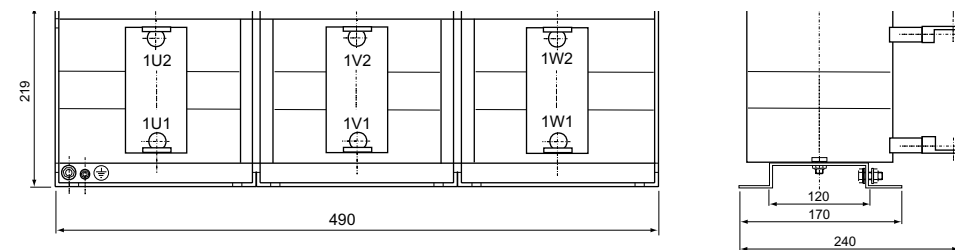

AGOIND009

Dimensions in mm



# NUM Servo Drives

## NUM Servo Drives







### Accessories

### Braking Resistors: Technical Characteristics, Outline Drawings

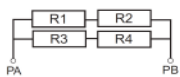
#### Technical Characteristics

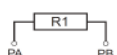
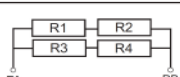
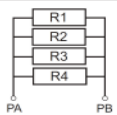
Brake resistance		AGORES008	AGORES009	AGORES010
Resistive value	Ohm	17	8.5	5.6
Continuous nominal power (room temperature 40°C)	W	480	480	2500
Energy pulse <500ms	kJ	12	12	125
Resistor thermal protection device by means of thermal switches		- Thermal switch fitted on the frame - 1 N.C. contact - Contact interruption 10A/250Vac - Operative contact > 400 °C (AGORES010 > 160°C)		
Degree of protection		IP00		
Weight	kg	0.35	0.35	5.6

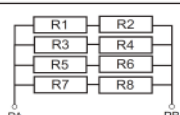
#### Facts to get to work examples

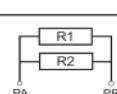
MDLL3 ...	Braking resistor	Connections configuration	Value [ $\Omega$ ]	P cont. [W]	Peak power <100ms [kW]
MDLL3015N00AN0I	AGORES008		17	480W	30kW
	AGORES008 (X4)			1920W	30kW
MDLL3030N00AN0I MDLL3025N00RN0I MDLL3025N00HN0I	AGORES008 (X2)		8.5	960W	61kW
	AGORES009			480W	61kW
	AGORES009 (X4)			1920W	61kW
MDLL3050N00RN0I MDLL3050N00HN0I	AGORES008 (X4)		4.25	1920W	120kW
	AGORES009 (X2) Basic configuration			960W	120kW
	AGORES009 (X8)			3840W	120kW
	AGORES010			2500W	100kW
MDLL3120N00HN0I	AGORES010		5.6	2500W	100kW (Peak power <1s)
	AGORES010 (X2)		2.8	5000W	200kW (Peak power <1s)

# NUM Servo Drives

## NUM Servo Drives

### Accessories

#### Brake resistance: Outline Drawings

#### Outline Drawings

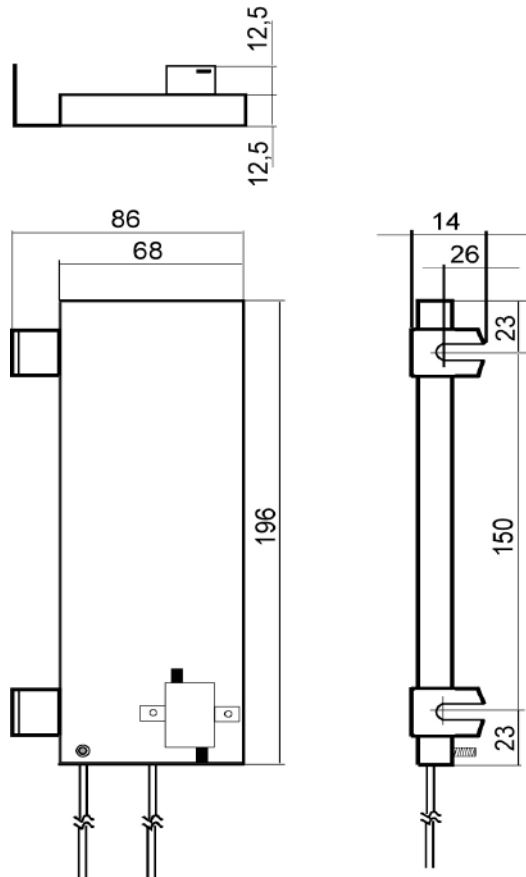

AGORES008 and AGORES009

Dimensions in mm

#### Outline Drawings

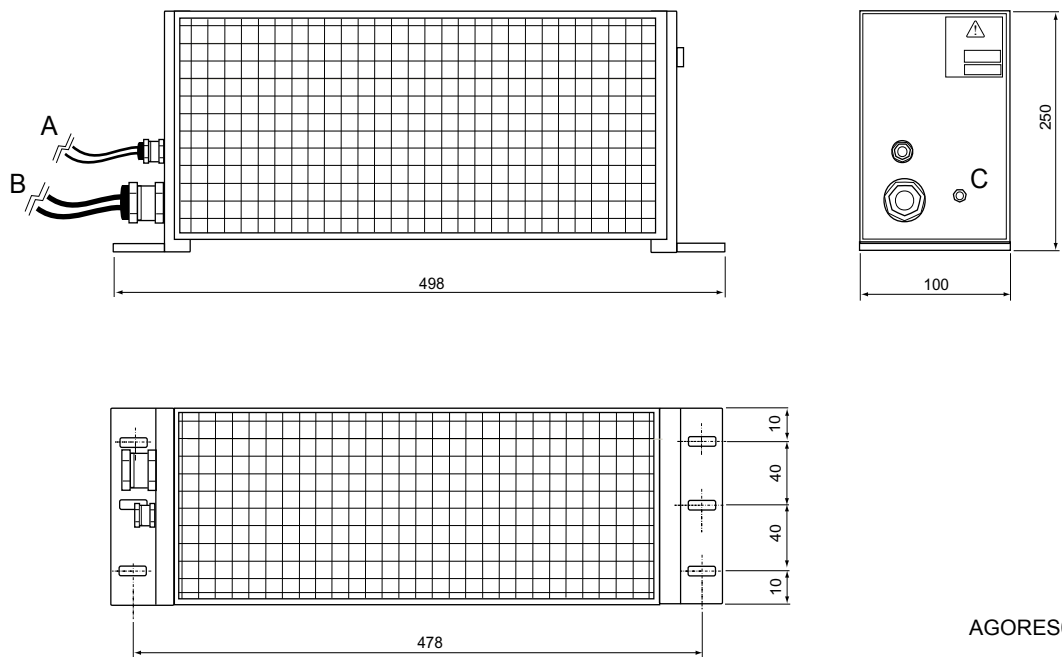

AGORES010

Dimensions in mm

# NUM Servo Drives

## NUM Servo Drives

### Accessories

### Mechanical Adapter: Outline Drawings

#### Outline Drawings

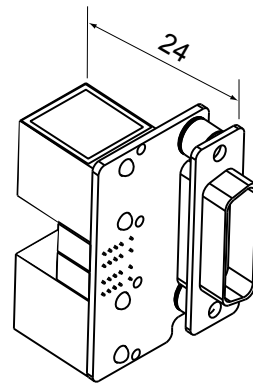
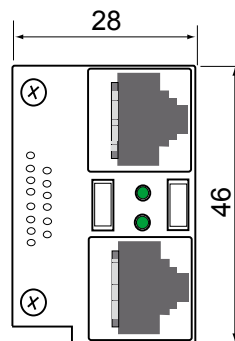
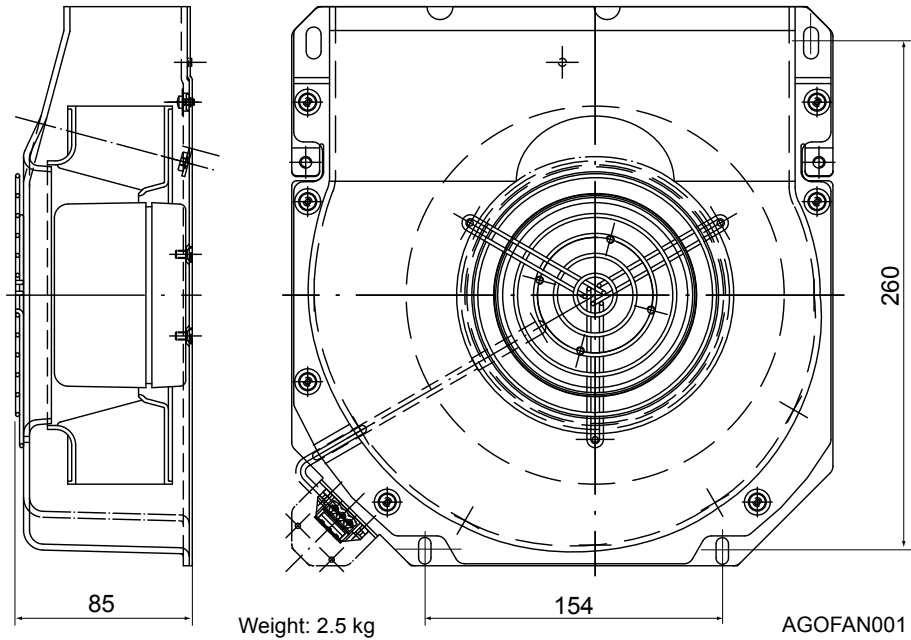

AEOADA010

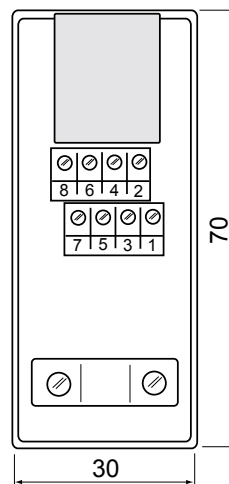
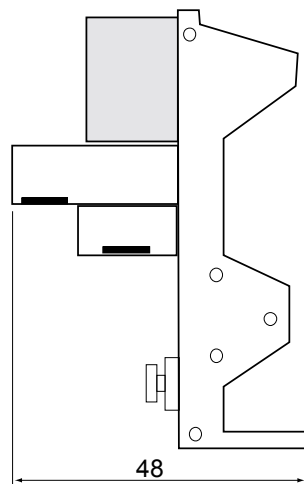

AEOADA011

Dimensions in mm

# NUM Servo Drives

NUM Servo Drives

Accessories

Mechanical Adapter: Outline Drawings

## Outline Drawings

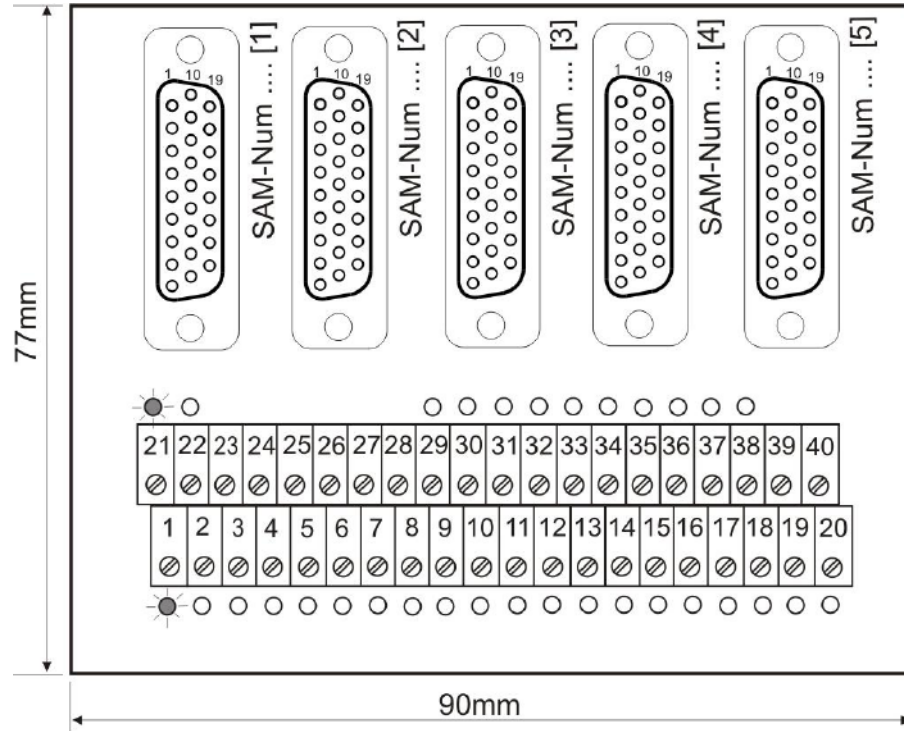

AEOADA006



# 7 Motor/Drive Associations

---

## Servo and Spindle Motors

### Table of Contents

---

	Page
<b>Servo Motors</b>	<b>135</b>
Association of BHX Motors with NUMDrive C (Switching Frequency 10 & 5 kHz)	135
Association of BPX Motors with NUMDrive C (Switching Frequency 10 & 5 kHz)	136
Association of BPH Motors with NUMDrive C (Switching Frequency 10 kHz)	137
Association of BPH Motors with NUMDrive C (Switching Frequency 5 kHz)	138
Association of BPG Motors with NUMDrive C (Switching Frequency 10 & 5 kHz)	139
Association of BHL Motors with NUMDrive C (Switching Frequency 10 & 5 kHz)	140
<b>Spindle Motors</b>	<b>141</b>
General Description	141
Services	141
Association of AMS and IM Spindle Motors with NUMDrive C (Switching Frequency 5 kHz)	142



# Motor/Drive Associations

## Servo and Spindle Motors

### Servo Motors

Association of BHX Motors with NUMDrive C (Switching Frequency 10 & 5 kHz)

#### Association of BHX Motors with NUMDrive C (Switching Frequency 10 kHz)

	MDLU3xxxx		014B	014A	021B	021A	034A	050B	050A	075A	130A	200A	400A
	Rated speed	Low speed cont. torque	Peak torque	Peak torque	Peak torque	Peak torque	Peak torque	Peak torque	Peak torque	Peak torque	Peak torque	Peak torque	Peak torque
	[rpm]	[Nm]	[Nm]	[Nm]	[Nm]	[Nm]	[Nm]	[Nm]	[Nm]	[Nm]	[Nm]	[Nm]	[Nm]
BHX0751V5...	6 000	1.2	4.3	4.3									
BHX0752V5...	6 000	2.1	6.6	6.6	7.8	7.8							
BHX0951V5...	6 000	2.4	6.4	6.4	7.5	7.5							
BHX0952N5...	3 000	4.3	13.2	13.2	14.5	14.5							
BHX0952V5...	6 000							7.8	10.5	14.5			
BHX1261N5...	3 000	4.5	11.5	11.5	13	13							
BHX1261V5...	6 000								9.5	12.4			
BHX1262N5...	3 000	8.4		13.8		20	27						
BHX1262V5...	6 000											22	22
BHX1263R5...	4 500	11						34	34				

#### Association of BHX Motors with NUMDrive C (Switching Frequency 5 kHz)

	MDLU3xxxx		014B	014A	021B	021A	034A	050B	050A	075A	130A	200A	400A
	Rated speed	Low speed cont. torque	Peak torque	Peak torque	Peak torque	Peak torque	Peak torque	Peak torque	Peak torque	Peak torque	Peak torque	Peak torque	Peak torque
	[rpm]	[Nm]	[Nm]	[Nm]	[Nm]	[Nm]	[Nm]	[Nm]	[Nm]	[Nm]	[Nm]	[Nm]	[Nm]
BHX0751V5...	6 000	1.2	4.3	4.3	4.3			4.3					
BHX0752V5...	6 000	2.1	6.6	6.6	7.8	7.8		7.8					
BHX0951V5...	6 000	2.4	6.4	6.4	7.5	7.5		7.5					
BHX0952N5...	3 000	4.3	13.2	13.2	14.5	14.5		14.5					
BHX0952V5...	6 000							7.8	7.8	10.5	10.5	14.5	14.5
BHX1261N5...	3 000	4.5	11.5	11.5	13	13		13					
BHX1261V5...	6 000							7	7	9.5	9.5	12.4	12.4
BHX1262N5...	3 000	8.4	13.8	13.8	20	20	27	27					
BHX1262V5...	6 000												16
BHX1263R5...	4 500	11				16.5	25	34	34				

7



# Motor/Drive Associations

## Servo and Spindle Motors

### Servo Motors

Association of BPX Motors with NUMDrive C (Switching Frequency 10 & 5 kHz)

#### Association of BPX Motors with NUMDrive C (Switching Frequency 10 kHz)

	MDLU3xxxx		014B	014A	021B	021A	034A	050B	050A	075A	130A	200A	400A
	Rated speed	Low speed cont. torque	Peak torque	Peak torque	Peak torque	Peak torque	Peak torque	Peak torque	Peak torque	Peak torque	Peak torque	Peak torque	Peak torque
	[rpm]	[Nm]	[Nm]	[Nm]	[Nm]	[Nm]	[Nm]	[Nm]	[Nm]	[Nm]	[Nm]	[Nm]	[Nm]
BPX0551V5...	6 000	0.5	1.5	1.5									
BPX0751V5...	6 000	1.4	4.3	4.3									
BPX0752V5...	6 000	2.3	6.6	6.6	7.8	7.8							
BPX0951V5...	6 000	2.7	6.4	6.4	7.5	7.5							
BPX0952N5...	3 000	5	13.2	13.2	14.5	14.5							
BPX0952V5...	6 000					10.5	14.5						
BPX1261N5...	3 000	5.2	11.5	11.5	13	13							
BPX1261V5...	6 000					9.5	12.4						
BPX1262N5...	3 000	9.8				20	27						
BPX1262V5...	6 000							22	22	27			
BPX1263R5...	4 500	12.6						34	34				

#### Association of BPX Motors with NUMDrive C (Switching Frequency 5 kHz)

	MDLU3xxxx		014B	014A	021B	021A	034A	050B	050A	075A	130A	200A	400A
	Rated speed	Low speed cont. torque	Peak torque	Peak torque	Peak torque	Peak torque	Peak torque	Peak torque	Peak torque	Peak torque	Peak torque	Peak torque	Peak torque
	[rpm]	[Nm]	[Nm]	[Nm]	[Nm]	[Nm]	[Nm]	[Nm]	[Nm]	[Nm]	[Nm]	[Nm]	[Nm]
BPX0551V5...	6 000	0.5	1.5	1.5	1.5								
BPX0751V5...	6 000	1.4	4.3	4.3	4.3			4.3					
BPX0752V5...	6 000	2.3	6.6	6.6	7.8	7.8		7.8					
BPX0951V5...	6 000	2.7	6.4	6.4	7.5	7.5		7.5					
BPX0952N5...	3 000	5	13.2	13.2	14.5	14.5		14.5					
BPX0952V5...	6 000						14.5	14.5					
BPX1261N5...	3 000	5.2	11.5	11.5	13	13		13					
BPX1261V5...	6 000							12.4	12.4				
BPX1262N5...	3 000	9.8	13.8	13.8	20	20	27	27					
BPX1262V5...	6 000							22	22	27			
							16						
BPX1263R5...	4 500	12.6				16.5	25	34	34				

# Motor/Drive Associations

## Servo and Spindle Motors

### Servo Motors

Association of BPH Motors with NUMDrive C (Switching Frequency 10 kHz)

#### Association of BPH Motors with NUMDrive C (Switching Frequency 10 kHz)

	MDLU3xxxx		014B	014A	021B	021A	034A	050B	050A	075A	130A	200A	400A	
	Rated speed	Low speed cont. torque	Peak torque	Peak torque	Peak torque	Peak torque	Peak torque	Peak torque	Peak torque	Peak torque	Peak torque	Peak torque	Peak torque	
	[rpm]	[Nm]	[Nm]	[Nm]	[Nm]	[Nm]	[Nm]	[Nm]	[Nm]	[Nm]	[Nm]	[Nm]	[Nm]	
BPH0751N5...	3 000	1.3	5.2	5.2										
BPH0751V5...	6 000		3.9	3.9										
BPH0752N5...	3 000	2.3	7.5	7.5										
BPH0752V5...	6 000		5.9	5.9										
BPH0754N5...	3 000	4	11	11										
BPH0952N5...	3 000	4.3	11	11										
BPH0952V5...	6 000					10								
BPH0953N5...	3 000	6		11.2		16								
BPH0953V5...	6 000						14	14						
BPH0955N5...	3 000	9.2				22								
BPH1152N5...	3 000	7.4		11.9		16								
BPH1152V5...	6 000							14	14					
BPH1153K5...	2 000	10.5		17.2		24								
BPH1153N5...	3 000							22	22					
BPH1153V5...	6 000							18	18					
BPH1154K5...	2 000	13.3				27								
BPH1154N5...	3 000							27	27					
BPH1154V5...	6 000								23	23				
BPH1156N5...	3 000	18.7						33	33					
BPH1422K5...	2 000	12				22								
BPH1422N5...	3 000							31	31					
BPH1422R5...	4 250							19	19					
BPH1423K5...	2 000	17						33	33					
BPH1423N5...	3 000							28	28					
BPH1423R5...	4 250								28	28				
BPH1424K5...	2 000	22						41	41					
BPH1424N5...	3 000								41	41				
BPH1424R5...	4 250									45				
BPH1427N5...	3 000	35									71			
BPH1902K5...	2 000	25							40	40				
BPH1902N5...	3 000									35				
BPH1902R5...	4 250											36		
BPH1903K5...	2 000	36								52				
BPH1903N5...	3 000											54		
BPH1904K5...	2 000	46								90				
BPH1904N5...	3 000											92		
BPH1905H5...	1 500	56								82				
BPH1905L5...	2 500											79		
BPH1907K5...	2 000	75									120			
BPH1907N5...	3 000												125	
BPH190AK5...	2 000		100											145

# Motor/Drive Associations

## Servo and Spindle Motors

### Servo Motors

Association of BPH Motors with NUMDrive C (Switching Frequency 5 kHz)

#### Association of BPH Motors with NUMDrive C (Switching Frequency 5 kHz)

	MDLU3xxxx		014B	014A	021B	021A	034A	050B	050A	075A	130A	200A	400A
	Rated speed	Low speed cont. torque	Peak torque	Peak torque	Peak torque	Peak torque	Peak torque	Peak torque	Peak torque	Peak torque	Peak torque	Peak torque	Peak torque
	[rpm]	[Nm]	[Nm]	[Nm]	[Nm]	[Nm]	[Nm]	[Nm]	[Nm]	[Nm]	[Nm]	[Nm]	[Nm]
BPH0751N5...	3 000	1.3	5.2	5.2									
BPH0751V5...	6 000		3.9	3.9									
BPH0752N5...	3 000	2.3	7.5	7.5									
BPH0752V5...	6 000		5.9	5.9									
BPH0754N5...	3 000	4	11	11									
BPH0952N5...	3 000	4.3	11	11									
BPH0952V5...	6 000		7.2	7.2	10	10							
BPH0953N5...	3 000	6	11.2	11.2	16	16							
BPH0953V5...	6 000						14	14	14				
BPH0955N5...	3 000	9.2	15.7	15.7	22	22							
BPH1152N5...	3 000	7.4	11.9	11.9	16	16							
BPH1152V5...	6 000						14	14	14				
BPH1153K5...	2 000	10.5	17.2	17.2	24	24							
BPH1153N5...	3 000						22	22	22				
BPH1153V5...	6 000						18	18	18				
BPH1154K5...	2 000	13.3	19.8	19.8	27	27							
BPH1154N5...	3 000						27	27	27				
BPH1154V5...	6 000							23	23	23			
BPH1156N5...	3 000	18.7					33	33	33				
BPH1422K5...	2 000	12	19.2	19.2	22	22							
BPH1422N5...	3 000						20	31	31				
BPH1422R5...	4 250						19	19	19				
BPH1423K5...	2 000	17					33	33	33				
BPH1423N5...	3 000						28	28	28				
BPH1423R5...	4 250							28	28	28			
BPH1424K5...	2 000	22					41	41	41				
BPH1424N5...	3 000							41	41	41			
BPH1424R5...	4 250									45			
BPH1427N5...	3 000	35								71			
BPH1902K5...	2 000	25						40	40	40			
BPH1902N5...	3 000							35	35	35			
BPH1902R5...	4 250									36			
BPH1903K5...	2 000	36						52	52	52			
BPH1903N5...	3 000									54			
BPH1904K5...	2 000	46								90			
BPH1904N5...	3 000									69			
BPH1905H5...	1 500	56						82	82	82			
BPH1905L5...	2 500									79			
BPH1907K5...	2 000	75								120			
BPH1907N5...	3 000										125		
BPH190AK5...	2 000	100									145		

# Motor/Drive Associations

## Servo and Spindle Motors

### Servo Motors

Association of BPG Motors with NUMDrive C (Switching Frequency 10 & 5 kHz)

#### Association of BPG Motors with NUMDrive C (Switching Frequency 10 kHz)

	MDLU3xxxx		014B	014A	021B	021A	034A	050B	050A	075A	130A	200A	400A
	Rated speed	Low speed cont. torque	Peak torque	Peak torque	Peak torque	Peak torque	Peak torque	Peak torque	Peak torque	Peak torque	Peak torque	Peak torque	Peak torque
	[rpm]	[Nm]	[Nm]	[Nm]	[Nm]	[Nm]	[Nm]	[Nm]	[Nm]	[Nm]	[Nm]	[Nm]	[Nm]
BPG0751N5...	3 000	1.3	5.2	5.2									
BPG0752N5...	3 000	2.3	7.5	7.5									
BPG0952N5...	3 000	4.3	11	11									
BPG0953N5...	3 000	6		11.2		16							
BPG1152N5...	3 000	7.4		11.9		16							
BPG1153K5...	2 000	10.5		17.2		24							
BPG1153N5...	3 000							22	22				
BPG1153V5...	6 000							18	18				
BPG1422N5...	3 000	12						31	31				
BPG1423N5...	3 000	17						28	28				
BPG1424K5...	2 000	22						41	41				
BPG1424R5...	4 250									45			
BPG1427N5...	3 000	35									71		
BPG1902K5...	2 000	25							40	40			
BPG1902N5...	3 000									35			
BPG1903K5...	2 000	36								52			
BPG1903N5...	3 000										54		
BPG1904N5...	3 000	46									92		
BPG1905L5...	2 500	56									79		

#### Association of BPG Motors with NUMDrive C (Switching Frequency 5 kHz)

	MDLU3xxxx		014B	014A	021B	021A	034A	050B	050A	075A	130A	200A	400A
	Rated speed	Low speed cont. torque	Peak torque	Peak torque	Peak torque	Peak torque	Peak torque	Peak torque	Peak torque	Peak torque	Peak torque	Peak torque	Peak torque
	[rpm]	[Nm]	[Nm]	[Nm]	[Nm]	[Nm]	[Nm]	[Nm]	[Nm]	[Nm]	[Nm]	[Nm]	[Nm]
BPG0751N5...	3 000	1.3	5.2	5.2									
BPG0752N5...	3 000	2.3	7.5	7.5									
BPG0952N5...	3 000	4.3	11	11									
BPG0953N5...	3 000	6	11.2	11.2	16	16							
BPG1152N5...	3 000	7.4	11.9	11.9	16	16							
BPG1153K5...	2 000	10.5	17.2	17.2	24	24							
BPG1153N5...	3 000						22	22	22				
BPG1153V5...	6 000						18	18	18				
BPG1422N5...	3 000	12					20	31	31				
BPG1423N5...	3 000	17					28	28	28				
BPG1424K5...	2 000	22					41	41	41				
BPG1424R5...	4 250									45			
BPG1427N5...	3 000	35								71			
BPG1902K5...	2 000	25						40	40	40			
BPG1902N5...	3 000							35	35	35			
BPG1903K5...	2 000	36						52	52	52			
BPG1903N5...	3 000									54			
BPG1904N5...	3 000	46								69			
BPG1905L5...	2 500	56								79			

# Motor/Drive Associations

## Servo and Spindle Motors

### Servo Motors

Association of BHL Motors with NUMDrive C (Switching Frequency 10 & 5 kHz)

#### Association of BHL Motors with NUMDrive C (Switching Frequency 10 kHz)

	MDLU3xxxx		014B	014A	021B	021A	034A	050B	050A	075A	130A	200A	400A
	Rated speed	Low speed cont. torque	Peak torque	Peak torque	Peak torque	Peak torque	Peak torque	Peak torque	Peak torque	Peak torque	Peak torque	Peak torque	Peak torque
	[rpm]	[Nm]	[Nm]	[Nm]	[Nm]	[Nm]	[Nm]	[Nm]	[Nm]	[Nm]	[Nm]	[Nm]	[Nm]
BHL2601N5...	3 000	85										210	
BHL2601N1...		112										210	
BHL2602K5...	2 000	120										290	
BHL2602K1...		160										290	

#### Association of BHL Motors with NUMDrive C (Switching Frequency 5 kHz)

	MDLU3xxxx		014B	014A	021B	021A	034A	050B	050A	075A	130A	200A	400A
	Rated speed	Low speed cont. torque	Peak torque	Peak torque	Peak torque	Peak torque	Peak torque	Peak torque	Peak torque	Peak torque	Peak torque	Peak torque	Peak torque
	[rpm]	[Nm]	[Nm]	[Nm]	[Nm]	[Nm]	[Nm]	[Nm]	[Nm]	[Nm]	[Nm]	[Nm]	[Nm]
BHL2601N5...	3 000	85									145		
BHL2601N1...		120										210	
BHL2602K5...	2 000	120									205		
BHL2602K1...		139									205		
		160										290	

# Motor/Drive Associations

## Servo and Spindle Motors

### Spindle Motors

#### General Description

#### Services

### General Description

AMS Motor Power vs Speed and Torque vs Speed Characteristics

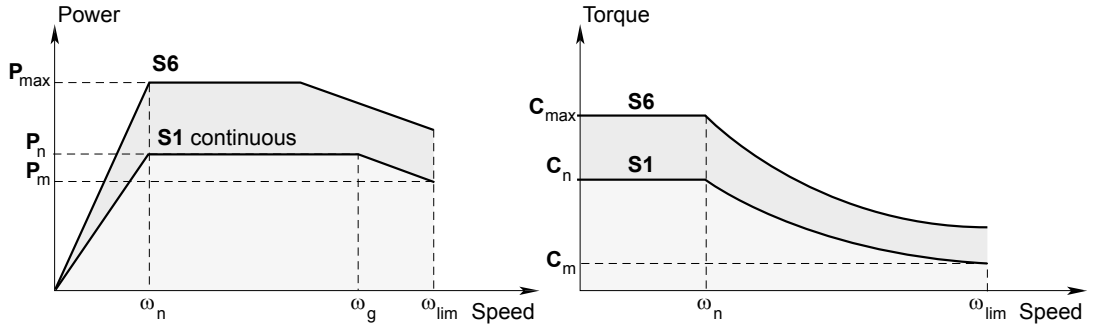

- $P_n$  = Rated continuous power (S1)
- $P_{max}$  = Overload power (S6)
- $P_m$  = Continuous power at maximum speed (S1)
- $\omega_n$  = Rated speed
- $C_n$  = Rated torque
- $C_{max}$  = Overload torque (S6)
- $\omega_g$  = Maximum speed at constant power (S1)
- $\omega_{lim}$  = Maximum speed
- $I_{cont}$  = Rated continuous current (S1)
- $I_{ms}$  = Overload current with the associated drive (S6)

### Services

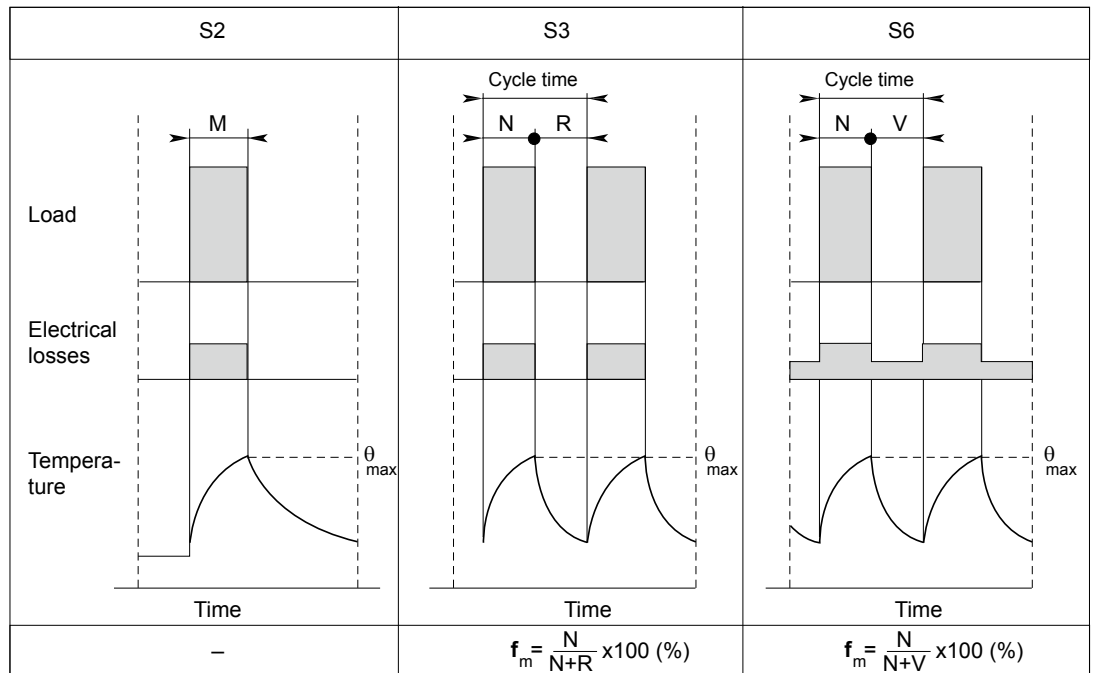

- N** = Operation at power  $P_{max}$
- R** = Idle
- V** = Off-load operation
- f<sub>m</sub>** = Duty cycle

# Motor/Drive Associations

## Servo and Spindle Motors

### Spindle Motors

Association of AMS and IM Spindle Motors with NUMDrive C  
(Switching Frequency 5 kHz)

#### Association of AMS Spindle Motors with NUM HP Drive

AMS ...	Connection	MDLU3xxxx	Continuous operation								Overload			
			S1								S6			
			Pn (kW)	$\omega_n$ (rpm)	$\omega_g$ (rpm)	$\omega_{lim}$ (rpm)	Pm (kW)	Cn (Nm)	Icont (Ams)	Pmax (kW)	Cmax (Nm)	Ims (Ams)	10 min (%)	
100	SB	Y	050A	3.7	1 500	6 500	6 500	3.7	24	20	6	40	35	22
			050B											
	MB	Y	075A	5.5				5.5	35	26	10	80	53	13
	GB	Y	130A	9				9	57	39	17	120	71	16
	SD	Y	050A	3.7	1 500	6 500	12 000	1.8	24	20	6	40	35	22
			050B											
	MD	Y	075A	5.5				2.8	35	26	10	80	53	13
GD	Y	130A	9	1 500	8 200		6.2	57	39	17	120	71	16	
132	SA	Y	075A	5	750	6 000	7 000	2.8	64	26	10	150	53	16
	SC	Y	130A	10	1 500	6 000		8	64	39	19	122	71	20
	SE	D	130A	15	1 750	4 000		10	82	52	23	110	71	30
	MA	Y	130A	7.5	750	6 000		5.7	95	39	15	190	71	20
	MC	Y	130A	15	1 500	6 000		12.5	95	52	21	134	71	37
	ME	D	200A	19.5	2 000	6 500		19	100	72	35	149	106	30
	LA	Y	130A	11	750	6 000		9	140	52	15	191	71	37
	LE	Y	200A	22	1 250	4 200	15	168	72	36	229	106	30	
	SF	Y	075A	5	750	6 000	10 000	2	64	26	10	150	53	16
	SG	Y	130A	10	1 500	6 000		6	64	39	19	122	71	20
	SH	D	130A	15	1 750	4 000		7.5	82	52	23	110	71	30
	MF	Y	130A	7.5	750	6 000		4	95	39	15	190	71	20
	MG	Y	130A	15	1 500	6 000		9	95	52	21	134	71	37
	MH	D	200A	19.5	2 000	6 500		13.5	100	72	35	134	106	30
	LF	Y	130A	11	750	6 000		9 000	7	140	52	15	191	71
	LI	Y	130A	12.5	680	2 300	3		175	39	19	270	71	16
	LH	Y	200A	22	1 250	4 200	12		168	72	36	229	106	30
160	MA	Y	130A	18	650	1 300	8 500		2.7	264	52	24	355	71
		D			1 300	2 600		5.4	132	178				
	MB	Y	200A	26	1 200	2 400	7.3	208	72	36	290	106	35	
		D			2 400	5 500					14.5			104
	MC	D	200A	36	1 700	2 800	11.8	202	100	47	265	141	10	
	LA	Y	130A	18	500	1 000	6 500	2.8	344	52	24	463	71	35
		D			1 000	2 500		5.6	172			231		
	LB	Y	200A	26	950	1 900	7.6	260	72	36.4	364	106	35	
		D			1 900	4 000					15.2			130
	LC	D	200A	36	1 050	2 100	11.6	328	100	48	437	141	10	

(\*) Performance limited by drive type association (Bi-Axes drive)

#### IM Motor

	Connection	MDLU3xxxx	Continuous operation								Overload			
			S1								S6			
			Pn (kW)	$\omega_n$ (rpm)	$\omega_g$ (rpm)	$\omega_{lim}$ (rpm)	Pm (kW)	Cn (Nm)	Icont (Ams)	Pmax (kW)	Cmax (Nm)	Ims (Ams)	10 mn (%)	
IM18MK14...	YY	400A	55	1 050	2 100	7 500	16.5	500	145	76	690	200	40	

# 8 General Information

---

NUM Worldwide, Regulations

Table of Contents

---

	Page
<b>NUM Worldwide</b>	<b>145</b>
<b>Regulations</b>	<b>148</b>

---





# General Information

## NUM Worldwide, Regulations

### NUM Worldwide

#### NUM Worldwide

##### Headquarters

##### NUM Worldwide

Country	Address	Telephone	Fax, Email
<b>Switzerland</b>	NUM AG Battenhusstrasse 16 9053 Teufen	+41 71 335 04 11	+41 71 333 35 87 sales.ch@num.com service.ch@num.com

##### Subsidiaries, Distribution and Service

##### Europe

Country	Address	Telephone	Fax, Email
<b>Austria</b>	NUM, Verkaufsbüro Österreich Hafenstrasse 47-51 4020 Linz	+43 732 33 63 81	+41 713 33 35 87 sales.at@num.com service.ch@num.com
<b>Denmark</b>	Caverion A/S Teglvaenget 75 7400 Herning	+45 9627 4000	+45 9627 6511 herning@caverion.dk
<b>Finland</b>	NUCOS OY Keiserinviitta 16 33960 Pirkkala Tampere	+358 3 342 7100	+358 3 342 7130 oiva.viitanen@nucos.fi
<b>France</b>	NUM S.A.S. Immeuble le Naxos 56, rue des Hautes Pâtures 92737 Nanterre Cedex	Hotline: +33 156 47 58 06 Sales: +33 156 47 58 58	+33 156 47 58 90 sales.fr@num.com service.fr@num.com
<b>Germany</b>	NUM GmbH Zeller Strasse 18 73271 Holzmaden	+49 7023 7440-0	+49 7023 7440-10 sales.de@num.com service.de@num.com
<b>Germany North</b>	NUM GmbH Niederlassung Nord Sudfeldstrasse 29-31 58093 Hagen	+49 2331 7398473	+49 2331 7396564 sales.de@num.com service.de@num.com
<b>Germany East</b>	NUM GmbH	+49 9652 815970	sales.de@num.com service.de@num.com
<b>Italy</b>	NUM SpA Sede Legale Via F Somma 62 20012 Cuggiono (MI)	+39 02 97 969 350	39 02 97 969 351 sales.it@num.com service.it@num.com
<b>Spain</b>	NUM CNC HighEnd Applications S. A. ERREMENTARI PLAZA 8 Post Box 55 20560 Oñati	+34 943 78 02 65	sales.es@num.com service.es@num.com

Please see [www.num.com](http://www.num.com) for further contacts and most recent contact details.

# General Information

NUM Worldwide, Regulations

NUM Worldwide

## NUM Worldwide

### Subsidiaries, Distribution and Service

#### Europe

Country	Address	Telephone	Fax, Email
<b>Sweden</b>	ConRoCo AB Formvägen 1 77793 Söderbärke	+46 240 65 01 16	+46 240 65 01 21 info@conroco.com
<b>Switzerland</b>	NUM SA Rue du Marché Neuf 30 2500 Bienne 3	+41 32 346 50 50	+41 32 346 50 59 sales.ch@num.com service.ch@num.com
<b>United Kingdom</b>	NUM (UK) Ltd. Unit 5 Fairfield Court Seven Stars Industrial Estate Wheler Road Coventry, CV3 4LJ	0871 750 40 20 International: +44 2476 301 259	0871 750 40 21 International: +44 2476 305 837 sales.uk@num.com service.uk@num.com
<b>Turkey</b>	NUM Servis Turkiye Feyzullah Caddesi Kirli APT B Blok No: 17/4 34840 Maltepe-Istanbul	+90 542 265 80 54	+90 538 425 66 11 numserviceturkiye @yahoo.com.tr

#### Africa

Country	Address	Telephone	Fax, Email
<b>Algeria (Maghreb)</b>	R.M.O France 2 rue Paul Herbe 95200 Sarcelles	+33 1 39 90 71 10	rmoacn@yahoo.fr
	NUM S.A.S. Immeuble le Naxos 56, rue des Hautes Pâtures 92737 Nanterre Cedex	+33 1 56 47 58 00	+33 1 56 47 58 90 sales.fr@num.com service.fr@num.com
<b>South Africa</b>	MTP Retrofitting Services Fraser Street 12 Building K2, Vanderbijlpark 1900 P.O. Box 1187	+27 16 931 0642	+27 86 546 0547 abraham@mtpsa.co.za

#### Americas

Country	Address	Telephone	Fax, Email
<b>USA</b>	NUM Corporation 603 East Diehl Road, Suite 115 Naperville, IL 60563	+1 630 505 77 22	+1 630 505 77 54 sales.us@num.com service.us@num.com
<b>Brazil</b>	LOSUNG Technical Assistance and Comerce Ltda. Av. Anápolis, 500 06404-250 Bethaville-BARUERI-SP	+55 11 419 13 714	+55 11 419 58 210 losung@uol.com.br
<b>Mexico (Central America)</b>	VISI Series México, S.A. de C.V. Sierra de Ahuacatlan, No. 136 Villas del Sol Santiago de Querétaro, Qro. CP 76046	+1 442 248 2125	+1 442 223 6803 service.mx@num.com

Please see [www.num.com](http://www.num.com) for further contacts and most recent contact details.

# General Information

NUM Worldwide, Regulations

NUM Worldwide

## NUM Worldwide

### Subsidiaries, Distribution and Service

#### Asia/Australia

Country	Address	Telephone	Fax, Email
<b>China</b>	NUM S.A. Beijing Office Room 904, No. 4 Building, Brilliancy International Plaza, Shangdi 10th Street, Haidian District, Beijing 100085	+86 (0)519 8585 0766	+86 (0)519 8585 0768 sales.cn@num.com service.cn@num.com
	NUM Numerical Control Technology (Changzhou) Co. Ltd The 5th floor, Haiye building No. 1-2 Guihua Road, Zhonglou District 213023 Changzhou	+86 (0)519 8585 0766	+86 (0)519 8585 0768 sales.cn@num.com service.cn@num.com
	JTSC Co. LTD Wuhan Room 302, Fengcai Building B, Huifeng Qiyezongbu, No. 2 Gutian Road, Qiaokou District, Wuhan City, Hubei Province	+86 27 8331 3040	+86 27 8331 3040 junzhuyu@tom.com
	Mingliwang Guangdong No. L23, Changrong Mechanic & Metals Plaza, Changan Town, Dongguan City, Guangdong Province	+86 10 5885 1991/98	+86 10 5885 1990 HYW2003gz@163.com
<b>Malaysia</b>	IME Trading Sdn. Bhd. 30A, Jalan PJS 1/46, Petaling Utama 46150 Petaling Jaya, Selangor	+60 3 7783 6866	+60 3 7783 4384 tk@cadcam.com.my
<b>Taiwan</b>	NUM Taiwan Ltd. 7F-2 No. 536, Sec. 2 Taiwan Boulevard Taichung City 40353	+886 4 2316 9600	+886 4 2316 9700 sales.tw@num.com service.tw@num.com
<b>Thailand</b>	Gsixty Co. Ltd. 508/51 Sukhontasawat Road Ladphrao, Bangkok 10230	+66 2 578 34 54	+66 2 578 34 54 jameschaput@hotmail.com
<b>South Korea</b>	NUM CNC KOREA Co. Ltd. A-503, Hangang Xi-Tower, Yangcheon-ro 401, Gangseo-gu 157801 Seoul	+82 2 6968 5767	+82 2 6968 5760 sales.kr@num.com service.kr@num.com
<b>Australia</b>	Australian Industrial Mach. Serv. Pty. Ltd. 28 Westside Drive Laverton North Victoria 3026	+61 3 9314 3321	+61 3 9314 3329 enquiries @aimservices.com.au

#### India

Country	Address	Telephone	Fax, Email
<b>India</b>	Peschel Dynamics Vishwakrupa s. no. 1 , Hissa No. 4 Narhe Gaon, Pune 411041	+20 3241 6980	+20 2431 7310 info@pescheldynamics.com

Please see [www.num.com](http://www.num.com) for further contacts and most recent contact details.

# General Information

---

## NUM Worldwide, Regulations

### Regulations

---

#### Compliance with EU Directives Relative to Electromagnetic Compatibility (EMC) (89/336, 92/31 and 93/68) and Low Voltage (73/23 and 95/68)

---

The list of standards with which NUM CNCs and servo drives comply is given in the conformity statements which can be supplied on request.

The products described herein must be used in compliance with the recommendations given in our Installation and Wiring Guide (on CD-ROM with basic documentation or 938 960).

The products of this catalog are designed for integration in a machine complying with Machine Directive 89/392/EEC.

---

#### Export Terms for CNC products

---

1. – Because of their technical characteristics or in some case their utilization, certain of NUM's products may be required to comply with the requirements of Swiss or European regulations and/or US regulations concerning control of the final destination.

Relevant information is given on our purchase order acknowledgments, invoices and delivery notes.

These provisions apply to NUM's products so identified on our purchase order acknowledgments, invoices and delivery notes.

2. – Accordingly, the purchaser undertakes to fully comply in all respects with the regulations of his country and, as the case may be, with Swiss, European and / or US regulations relating to the control of final destination of dual use products.

The purchaser undertakes to introduce and to follow its own business control procedures in order to ensure that, in respect of the resale of Dual Use Products, such national legal obligations will be implemented.

3. – In any case, the purchase orders received by NUM shall be accepted subject to NUM obtaining any required authorizations.

© Copyright NUM AG, Teufen/CH, 2015 (MMA, DSc)

All rights reserved. No part of this document may be copied or reproduced in any form or by any means whatsoever, including photographic or magnetic processes. The transcription on an electronic machine of all or part of the contents is forbidden.

The software mentioned herein is the property of NUM AG. Each copy of the software confers on the holder a nonexclusive license strictly limited to use of the said copy. No copy or other form of duplication of this product is authorized, with the exception of backup copies of the software.

The physical, technical and functional characteristics of the hardware and software products and the services described in this document are subject to modification and cannot under any circumstances be construed as contractually binding.

NUM, Motorspindle and NUMtransfer are registered trademarks of NUM AG.

Windows is a registered trademark of Microsoft Corporation.

