

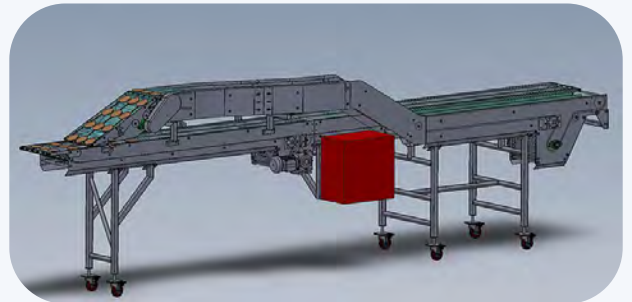

## Bespoke Design

### Special Application Conveyors

- Component assembly conveyors systems
- Bag levelling and pouch squeezing conveyors
- Jig conveyors
- Trimming, inspection and packing systems
- Flume and pump conveying
- Screw augers
- Metal detection belts
- Automated distribution conveyors
- Overhead chain conveyors
- Integrated weigh cell conveyors



*Split Level Conveyor - Design stage*

### Features

- Stainless steel and mild steel construction
- PU, PVC, rubber, steel, chain and wire belts
- Fixed, variable and indexing drive options
- Ingress protection from IP54 to IP67
- Open or closed framed design

### *Split Level Conveyor - Finished Product*

