

INDUSTRIAL MARKING AND PRODUCT IDENTIFICATION

www.ostling.com



LASEBOX

The compact "Ready to mark" Laser marking station

ALL IN ONE

- Laser protective housing (Laser protection class 1)
- Laser System (5, 10, 20, 30 or 40 watts)
- All supply units integrated
- Automatic electronic Z-axis
- Prepared for extraction system

IDEAL SOLUTION FOR:

- Contract marking
- Industry
- Integrators
- Laboratories and Medical technology
- Individual marks, small to medium runs



The LaseBox is designed as a "Plug & Play" laser station - simply connect via USB to a PC and you are ready to go. The simple operation, and easy loading and unloading thanks to the automatic sliding door, provides the perfect compact yet powerful solution.

Despite its compact footprint the LaseBox has a remarkably large load capacity. Depending on the F-Theta lens used, a marking area of up to 120x120 mm is possible.

The LaseBox can be used as a stand-alone laser marking station or integrated easily into a production line. Using the market proven software, XS designer, automated marks, such as sequential serial numbers, 2D codes (Data Matrix™), etc can be easily generated.

Strengths of the Östling LaseBox

- Maximum safety (laser protection class 1)
- Mobile and flexible, minimum weight of 33 kg, compact "TableTop" design
- Automatic sliding door for rapid loading of parts to be marked
- Laser safety glass window for safe setup and observing of the marking process
- Large load capacity of 375x300x150mm (LxWxH) up to a weight of 40 kg
It is also possible to remove a panel from the rear of the cabinet providing the facility to mark much longer components, subject to safety regulations being followed.
- Programmable electric Z-axis with height adjustment for easy focusing
- T-slots for quick mounting and setting up of jigs and fixtures
- Near Maintenance free and silent operation
- Very energy-efficient with a Power Supply of 230 VAC - 50/60 Hz (max. 400 Watt)
- Available with an optional desk for ergonomic loading and unloading

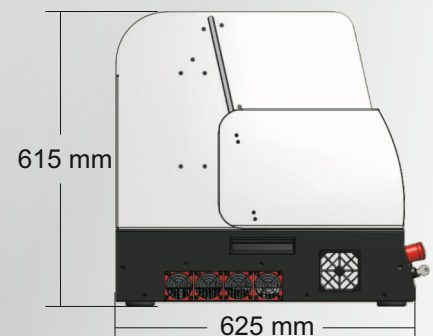
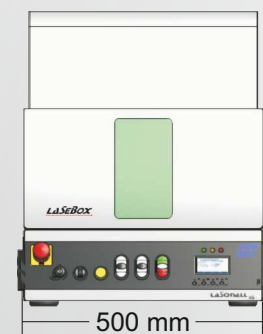

Laser marking Very flexible with high quality

Using a highly precise laser beam a permanent mark is applied to different materials e.g. different kinds of metal and plastic.

With the associated software your marking ideas have no limits. Also for automated markings, such as continuous serial numbers, 2D codes (Data Matrix™) etc our Laser marking systems are the best choice.

ÖSTLING
Markiersysteme GmbH
Broßhauser Straße 27
D-42697 Solingen

Fon +49 2 12 / 26 96 - 0
Fax +49 2 12 / 26 96 - 199

Email info@ostling.com
Internet www.ostling.com