



TEAM CLUB

GROUND CARE SPRAYER

*British designed and built
for British groundcare specialists*



300L x 6m version



TEAM CLUB

Standard features



Controls

Manually operated control valves to operate all spray and pressure functions.



Work station controlling primary functions to operate the sprayer and when cleaning or filling.



Chemical induction:
20L hopper for safe transfer of liquids and powders via a high flow suction system to the main tank, a rotary nozzle for cleaning containers.



Diaphragm pump:
High quality poly' diaphragm pump withstands any aggressive plant protection chemicals.



Clothes storage:
For all PPE equipment.



15L Clean water supply:
For hand washing.

Booms

Boom construction:
All booms are manufactured from steel tubular sections to guarantee strength and durability.

Boom height adjustment:
Manual 6-8m;
Winch 10 and 12m

Boom storage system secures boom assembly in the folded position for safe road transport.

Break back:
All booms are fitted with break back pivot points to protect against unforeseen obstacles.

Transport width:
Folds to compact
1.9m (6m model);
2.4m (12m model).

Tank flushing:
50L clean water supply for main tank flushing with internal rotary nozzle.





TEAM CLUB

Optional extras



Tank options:

- 300L
- 400L
- 500L
- 600L
- 800L



Water suction:

Enabling tank filling via the main pump.

Dual covered boom:

5.5 or 6m covered boom system for sensitive areas or windy conditions.

Walk on boom

Hydraulic lift booms (10/12m only)

In cab electric spray controls:

To operate all spray and pressure function.

Computerised spray rate controller

automatically adjusts spray application rate to forward speed.

Triple nozzle assemblies

enable the operator to select from a choice of 3 nozzle sizes for various applications.



Other optional extras

Stainless steel spray lines, bout/foam marker, retractable hose reel and hand lance kit, GPS boom section switching.



600L x 12m version



TEAM CLUB

Technical specifications

Item	Dimension
Tank capacities (L)	300, 400, 500, 600, 800
Pumps (type / L per min)	Poly 2073 / 73
Boom lengths (m)	4, 6, 7, 8, 10, 12
Weight (Kg)	175 (300L x 6m model); 285 (600L x 12m model)
Total height (m)	1.6 (6m); 2 (12m)
Total width (m)	1.9 (6m); 2.4 (12m)
Rinse tank (L)	50

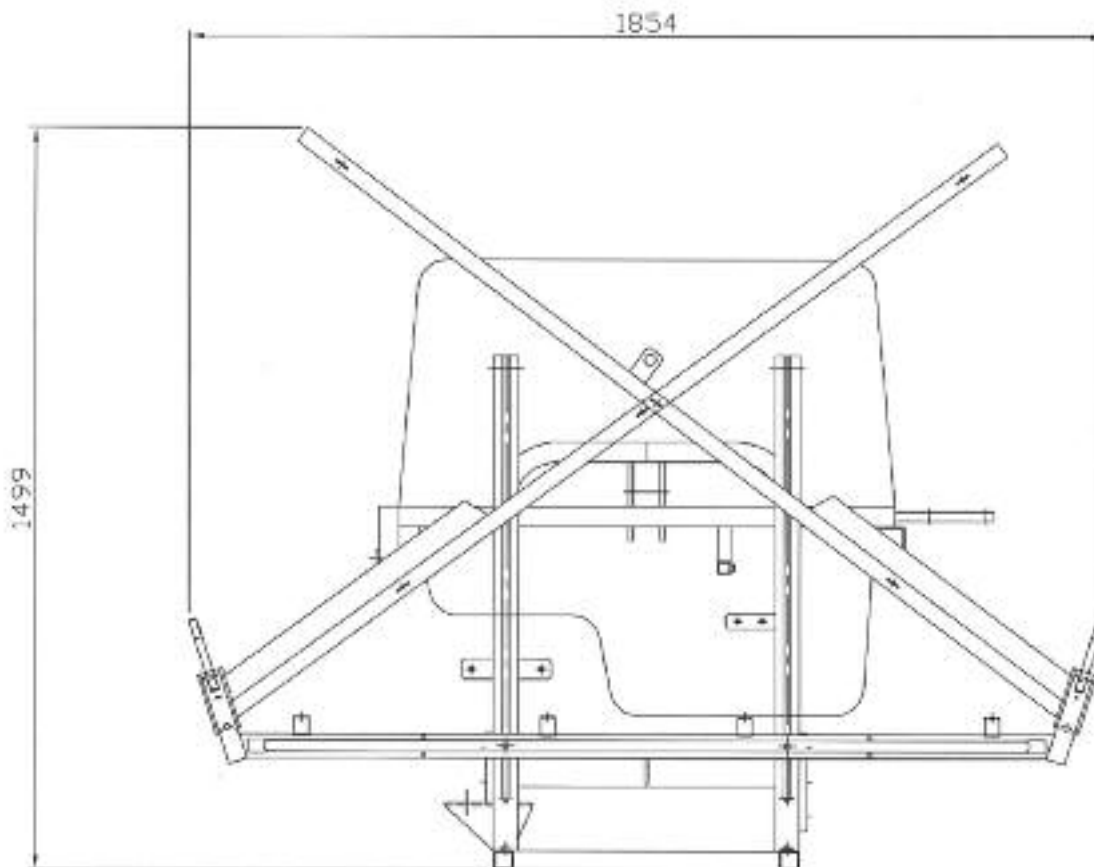

Team Sprayers Limited

Unit 3 Lancaster Way Business Park
Witchford, Ely, Cambs CB6 3NW

Tel: 01353 661 211 Fax: 01353 666 642

Email: sales@team-sprayers.com

www.teamsprayers.com

Leaders in the field of application