

Modular Rooflights

in polycarbonate and glass



The Skylight
Company

02392 359 831

Sales@theskylightcompany.co.uk



Rooflights & more...

Company profile

Whitesales has over 20 years' experience in the manufacture and distribution of speciality flat roofing products. As a company we have the dedication and resource to fulfil the most demanding of requirements throughout the UK. Our experienced and expert personnel have an in-depth knowledge of industry regulations, which ensures we provide up to date advice on fully compliant solutions. Also, we invest in ecologically friendly business processes meaning that our products are from sustainable sources.

Rooflights and more...

Whether you are a specifier, contractor or merchant, you will benefit from working with us. The following are just some of the reasons why you should choose Whitesales.

High quality products

Our speciality roofing products and accessories are tested to the highest standards and are suitable for use with most flat roof systems, including single ply, felt, hot-melt, asphalt, liquid, GRP and lead. Our tubular rooflights are ideal for use on pitched or flat roofs.

Nationwide coverage and next day delivery

With depots strategically located in England and Scotland, Whitesales offers nationwide next day delivery on our own transport or overnight carrier service. Deliveries can be direct to site or to contractor or merchant premises.

Technical advice and support

The Whitesales Customer Service Team is readily available to assist you, from your initial enquiry through to after sales support. This includes help with specification writing, site surveys, condition reports, budget costings and fully detailed quotations.

Guarantees

All products supplied are fully guaranteed including insurance backed guarantee on request.

Contents

2	Introduction
4	Product overview
6	Em-Dome range
8	Glazing options
10	Curb options
12	Security options
13	Access options
14	Smoke vent options
16	Ventilation options
20	Em-Dome size chart
22	How to specify checklist
24	Em-Glaze Modular range
26	Flat glazing options
28	Flat glazing curbs
29	Flat glazing ventilation
30	Em-Glaze size chart
32	Em-Tube tubular skylight range
34	Em-Tube technical data
36	Design considerations
38	Health and safety
39	Sitework
40	Operation and maintenance
42	Support services
43	Environment





“

We are

**renowned for proven
product ranges,**
industry leading levels
of service and expertise.

”

Why is natural daylight so important?

Natural daylight has long been recognised as the most effective form of light. Building Regulation Approved Document L requires designers to provide adequate daylight ‘...where rooflight areas are reduced below 20%, the building designer must take special care to demonstrate daylight levels remain adequate...’

Flat roof rooflights are the most efficient means of providing natural daylight, providing up to three times more daylight than an equally-sized vertical window. The light from a rooflight is also more evenly distributed throughout the room, less likely to result in glare or compromise of privacy.

Natural daylight is an invaluable natural asset. The benefits of a naturally-lit workspace are well documented and include increased productivity, work satisfaction and cost reduction, as well as significant reduction of impact to the environment. From a building design perspective the use of rooflights is an excellent means by which both light and solar energy can be utilised to save energy and to reduce the carbon footprint of any property.

There are specific industry policies and guide documents to assist with introducing naturally-lit space into different building types (especially schools). Whitesales can offer support and advice on the requirements for specific applications.

Product overview:



Em-Dome

Thermoformed dome and pyramid shape rooflights. Em-Domes are offered in a wide range of sizes and glazing options. See pages 6-23.



Em-Glaze Modular

Flat glass rooflights with polyester powder coated aluminium frame. Em-Glaze Modular units are available from stock with other bespoke sizes available to order. See pages 24-31.

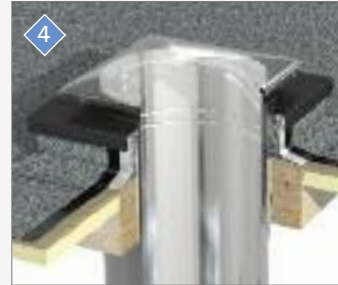

Em-Tube

Tubular skylights for flat or pitched roofs with either a rigid or flexible internal tube. Em-Tubes are available from stock in a range of sizes and accessory options. See pages 32-35.



Em-Vent

Smoke ventilators incorporating either glazed or solid covers. Em-Vents are available in sizes designed to meet current regulations and to suit site dimensions. Em-Hatch Access Hatches also available. See our dedicated brochure 'Smoke ventilation and access hatches'.

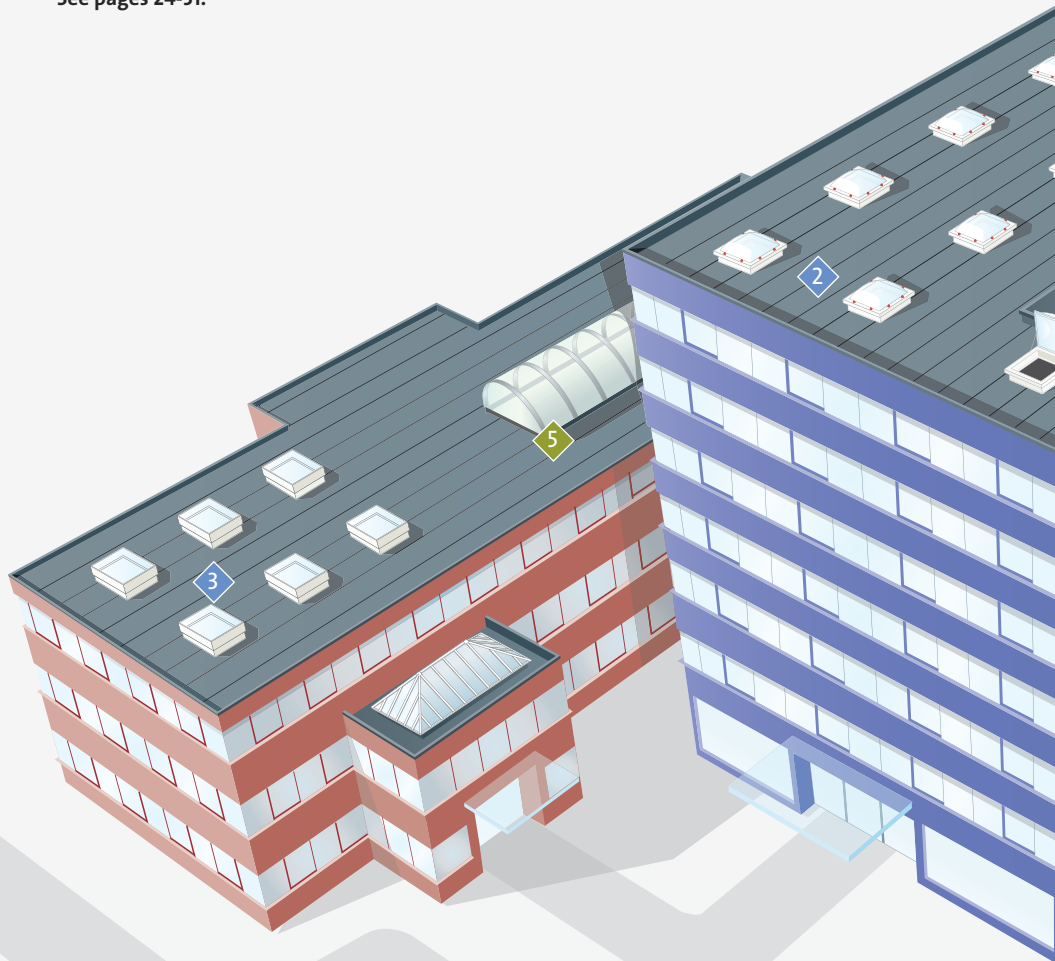

Whether you require design recommendations or have a project on site, Whitesales has the experience, product and service to meet that need.



Em-Vault

Barrel vaulted continuous sectional rooflights in polycarbonate. Em-Vaults are ideally suited to covering large areas and are made to measure. T-Vault GRP barrel vaults are also available as a functional alternative. **See our dedicated brochure 'Continuous rooflights'.**



Em-Glaze Monopitch

Continuous monopitch skylights in glass or polycarbonate with aluminium framework and cill sections. The Em-Glaze range also includes Ridgelight, Pyramid and Lantern varieties. **See our dedicated brochure 'Continuous rooflights'.**



Em-Trim

GRP roof edge trim. Em-Trim is available in a wide range of sizes and colours. T-Trim aluminium roof edge trim is also available along with Em-Bar and T-Bar termination bar. **See our dedicated brochure 'Roof trims and other accessories'.**



Em-Pad

Adjustable paving slab support pad. Em-Pads are adjustable height to allow accurate levelling of paving systems. T-Pad fixed unit is also available. The Accessories range also includes T-Vent breather vents, T-Sleeve pipe sleeves and T-Pipe drainage outlets. **See our dedicated brochure 'Roof trims and other accessories'.**



Em-Dome®

High quality thermoformed rooflights designed to make optimum use of natural light. Em-Domes are offered in a wide range of sizes, shapes and glazing options to meet virtually any specifier and client requirement.



Em-Dome in opal diffused with 300mm PVC upstand and rotating vents



Em-Dome pyramid in opal diffused with Em-Curb PVC 300

Description

Em-Dome rooflights are thermoformed from UV protected, co-extruded polycarbonate sheet and are available in single, double, triple, quad skin or Eco multiwall construction.

Polycarbonate Em-Domes use a minimum 3mm thick glazing and have been tested and certified according to EN 1873: 1200 Joules, and ACR(M): 001: 2005 Class B.

Em-Domes are tested to the highest standards and are proven suitable for use on most flat roofs, including single ply, felt, hot-melt, asphalt, liquid, GRP and lead. They are normally specified with our proprietary curbs (see page 10) but can also be installed on existing builder's curbs.

Higher security, access and ventilation options are available.

High security screwbolts

Unique to the Em-Dome are the patented high security screwbolts, supplied factory fitted as standard to all units. Once installed, the fixing cannot be removed using common tools. The screwbolt provides a high level of resistance to tampering or forced entry. The fixing screw or bolt is sleeved within the body of the screwbolt which avoids pressure being exerted on the rooflight glazing as the fixing is tightened. This virtually eliminates the risk of stress fractures caused by over-tightening.

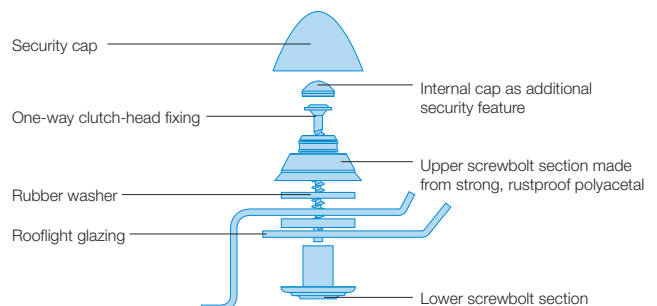

Em-Dome key features

- 1 Choice of dome, pyramid or trapezoidal shape
- 2 Compliant with HSG33 recommendations
- 3 Ventilation and access options available
- 4 A range of upstands to accommodate new roof insulation
- 5 Patented high security screwbolt fixing
- 6 Em-Curb upstand provides tidy detailing

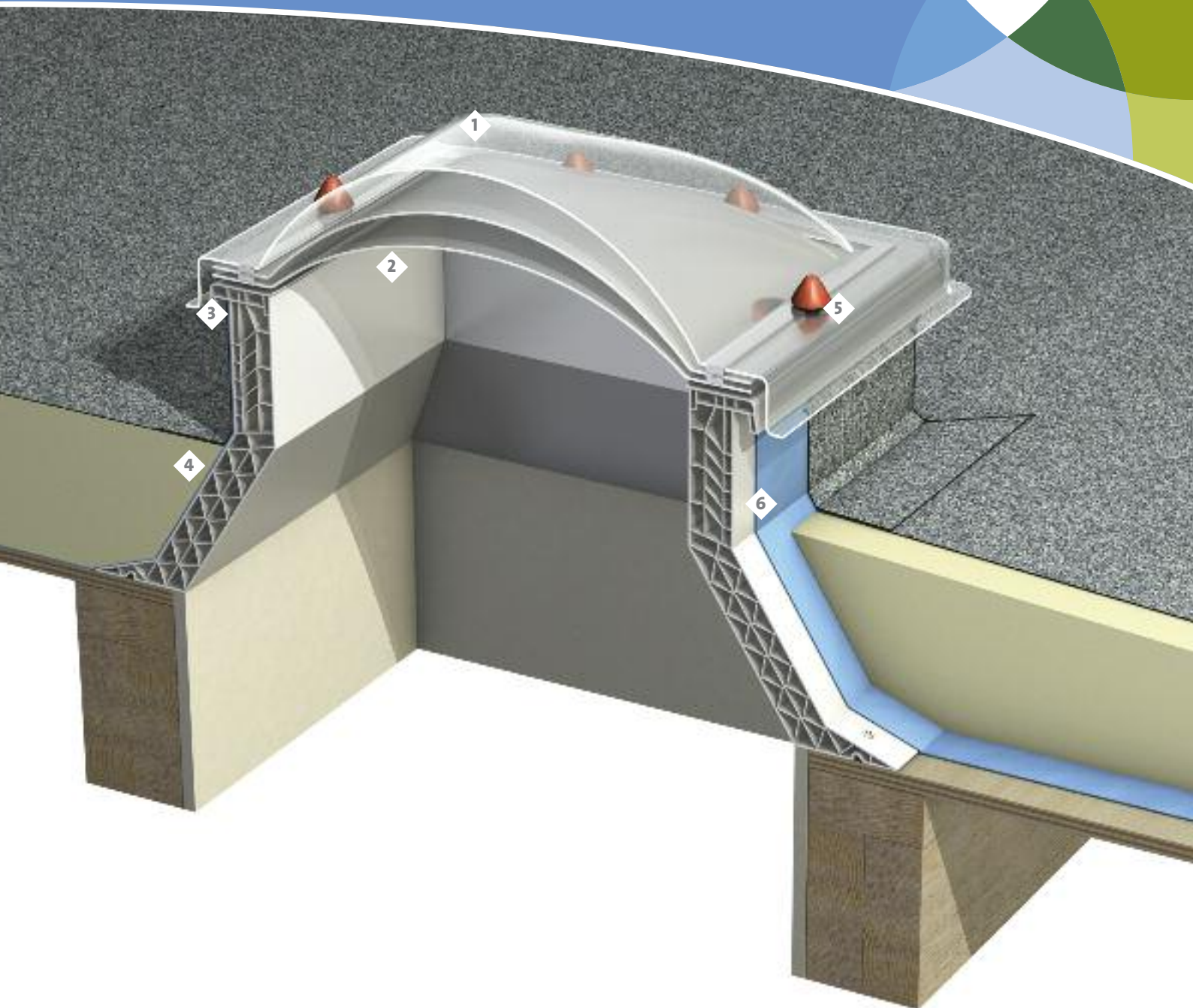

Glazing options

Features

Material

→ Polycarbonate

Skin

→ Single, double, triple, quad or multiwall construction

Glazing

→ Clear, opal diffused, bronze or 'HeatReflect'

Shape

→ Square, rectangular or circular

Size

→ From 300 x 300mm to 1800 x 3000mm



Em-Dome in clear and opal diffused with aluminium cowl

Thermoformed glazing

Em-Domes are thermoformed from polycarbonate sheet and are available in single, double and triple skin plus certain sizes available in quad skin or Eco multiwall construction. Polycarbonate is virtually unbreakable, with an impact strength up to 250 times greater than glass.

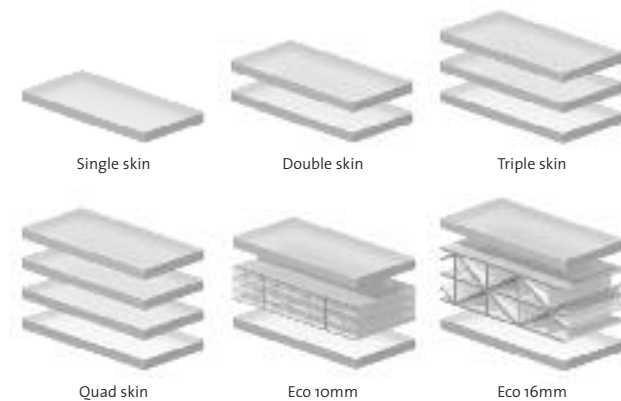

Em-Domes can be supplied in clear, opal diffused, bronze or 'HeatReflect' (reflects up to 68% of the heat radiation) glazing.



All polycarbonate Em-Domes have a minimum 3 mm outer thick glazing. Inner skin thickness may vary.

Shapes

Em-Domes are available in the following shapes:

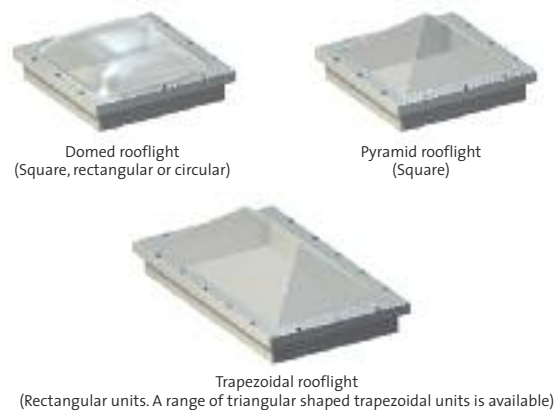

Sizes

Offered in an extensive range of over 140 sizes from 300 x 300mm, through to 1800 x 3000mm. Many sizes are available ex-stock for immediate delivery. Where units are to replace existing rooflights a range of curb adaptors is available.

See pages 22-23 for details on how to specify Em-Dome.

Performance

When installed in accordance with the manufacturer's recommendations, Em-Domes are expected to exceed the life of the roof covering. Em-Domes are guaranteed against the effects of defective design, materials or construction for ten years, subject to certain conditions. 'Special Project' guarantees are available including 20 year and insurance backed. For further details please contact Whitesales.

Performance of glazing materials

Typical values	Polycarbonate
----------------	---------------

Fire ratings

To BS 476: Part 3	AA
To BS 476: Part 7	Class 1*
To 1991 Building Regulations	Tp(a)

Service temperature	-50 to +120°C
---------------------	---------------

Information for 3mm thick glazing unless noted otherwise.

* Class o for Building Regulation purposes



Em-Dome circular in opal diffused with GRP upstand

Certification

Whitesales' Em-Dome rooflights are 'out-of plane' rooflights, and provided they are specified with polycarbonate glazing, can be deemed to be 'non-fragile'.

- ◆ Em-Dome polycarbonate rooflights have undergone large body impact testing by an independent accredited test organisation and test certificates are available to demonstrate compliance to an energy level of 1200 Joules when tested to pr EN 1873, and ACR(M)001: 2005 to Class B. They have also undergone hard body impact testing according to NBN EN 13964:2007.
- ◆ Polycarbonate Em-Domes have been awarded BBA Certificate No. 00/4691 and are manufactured to ISO 9001.
- ◆ Polycarbonate Em-Domes are manufactured in accordance with European standards and hold a CE mark according to EN 1873.
- ◆ Em-Dome rooflights, Em-Curb upstands, hinged opening frames and rotating ventilators are certified as providing adequate resistance to precipitation, according to EN 1873 – Weathertightness.

Glazing specification

	Single Clear	Single Opal	Single HeatReflect	Double Clear	Double Opal	Double HeatReflect
Light transmission (LT %)	88%	58%	50%	77%	51%	50%
Solar heat gain factor (g %)	83%	60%	61%	69%	50%	53%
Sound reduction (dB)	12	12	12	20	20	20
Thermal transmission (W/m ² K)	5.36	5.36	5.36	2.68	2.68	2.68
	Triple Clear	Triple Opal	Triple HeatReflect	Quad Clear	Eco 10	Eco 16
Light transmission (LT %)	70%	45%	45%	60%	35%	31%
Solar heat gain factor (g %)	60%	43%	46%	47%	32%	30%
Sound reduction (dB)	22	22	22	23	21	22
Thermal transmission (W/m ² K)	1.78*	1.78*	1.78*	1.37	1.23	1.03

* Measured in hot box in the vertical BS EN ISO 12567-2: 2005

Curbs for new installations...

Features

- Used in conjunction with Em-Dome rooflights
- Exceptional thermal efficiency
- Em-Curbs for new installations
- Enhance overall appearance of the rooflight
- Prefinished white internally
- Heights available 150, 300, 350 and 500mm
- Available in white PVC-u or GRP



Em-Dome in opal diffused with 350mm PVC oversleeve upstand and rotating vents

Em-Curb upstands

Em-Curbs are designed to be used in conjunction with Em-Dome rooflights to provide a thermally broken interface which in turn helps to improve the overall thermal efficiency of the roof. Em-Curbs represent excellent value for money, enhance the overall appearance of the rooflight and are prefinished white internally, therefore requiring no further decoration.

Splayed Em-Curb upstands give an excellent spread of light through the room whilst the vertical units are available where the dimensions of the roof aperture need to be maintained.

The standard Em-Curb is made from extruded white PVC-u. The multi-chambered construction gives an exceptionally robust and thermally efficient performance. This curb is suitable for most roof finishes and is available in heights of 150, 300 and 350mm with other heights also available. All ventilation, access hatch and smoke vent options can be used in conjunction with Em-Curbs.

Em-Curbs can also be supplied in GRP which have integral 10mm polyurethane foam insulation and robust dome fixing and mounting flanges. They can be used with most roofing materials.

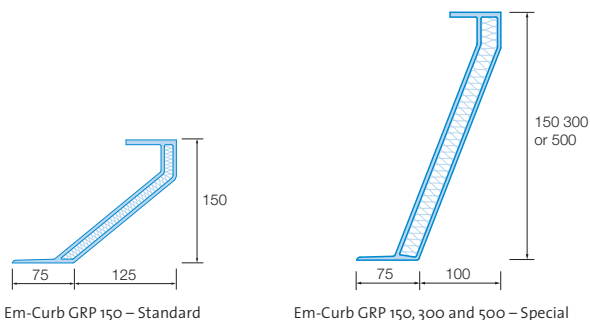

Thermal transmission

Values shown below are the calculated U-value, unless denoted otherwise. Complete unit U-values are available on request.

Typical values	U-value (W/m ² K)
Em-Curb PVC-u 150/s	2.20
Em-Curb PVC-u 150/v	1.00*
Em-Curb PVC-u 300/s	1.00*
Em-Curb PVC-u 350/s	0.89
Em-Curb GRP 150 Standard	1.82
Em-Curb GRP 150, 300 and 500 Special	1.07

* Measured in hot box in the vertical BS EN ISO 12567-2: 2005

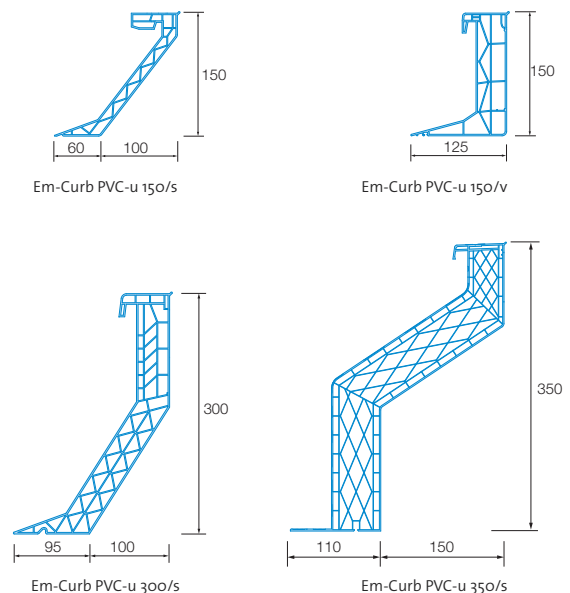

... and refurbishments

Em-Collar adaptors

Em-Collars provide a thermally broken solution for replacing existing rooflights and would typically be installed to an existing builder's upstand. Consideration should be given to using the PVC 350/s upstand to oversleeve existing site upstand as this reduces site work, especially where existing linings must not be disturbed, e.g. may contain asbestos.

T-Collar adaptors, collars and flanges

T-Collars are purpose made to fit any size or type of existing builder's curb or proprietary upstand and enable Em-Domes to be fitted where existing dimensions are irregular or a direct size match is not available.

Em-Collars and T-Collars are a flexible solution and can also incorporate all ventilation, access hatch and smoke vent options.



Em-Dome linked double units with Em-Collar and aluminium cowl

Em-Collar PVC Adaptor Collar

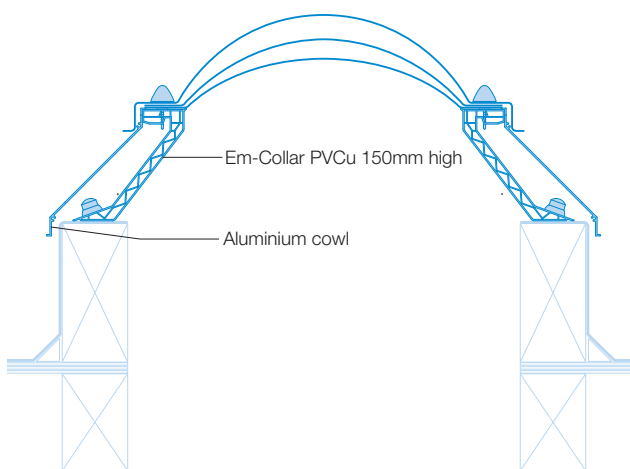

Em-Curb PVC Oversleeve Upstand

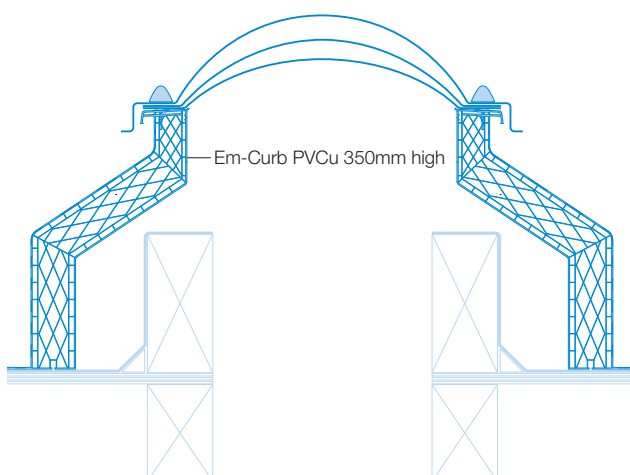

Multiple Em-Dome rooflights

For extra long applications, e.g. 3 to 6m, two or more Em-Domes can be installed together by means of linked T-Collar adaptors. These are self-supporting up to a span of 1m. For spans over 1m a structural support will be required. Where necessary, linked T-Collar adaptors are supplied in individual sections for jointing on site, utilising a standing seam detail.

Em-Curb upstands can also be used in conjunction with multiple rooflights.

For roof openings longer than 6m, we would normally recommend a continuous barrel vault rooflight (refer to the Whitesales 'Continuous rooflights' brochure).

Linked Em-Collar adaptor – jointing detail

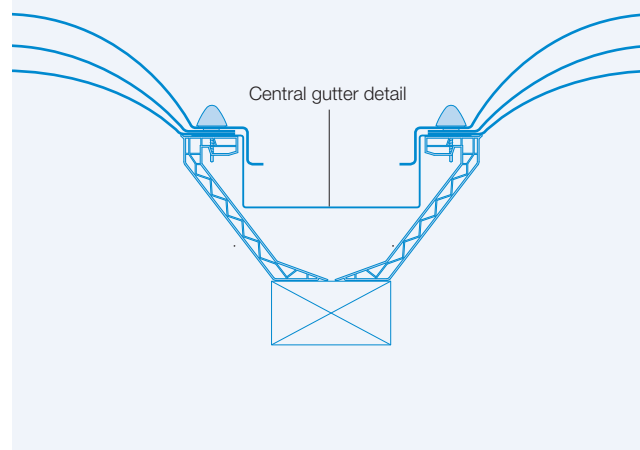

Security options: Em-Dome Plus

Features

- Fully enclosed tamper-proof frame
- High security fixing detail
- Simple to install
- Unobtrusive appearance with no visible fixings
- Completely weatherproof
- Self-draining



Em-Dome in opal diffused with 300mm PVC upstand and 'Em-Dome Plus' security frame

Description

A fully enclosed, tamper-proof frame for a totally secure fixing, Em-Dome Plus is simple to install and provides a neat, unobtrusive appearance, with no visible fixings. The design of the frame allows for a completely weatherproof, self-draining construction, incorporating standard Em-Domes in single, double or triple skin construction. The Em-Dome Plus frame is made from aluminium extrusions to BS 1474, Quality 6063/T6, and is supplied in mill finish. Polyester powder coated frames are also available.

Performance

Em-Dome Plus security rooflights will not rust or be affected by atmospheric pollution. Once installed, they are maintenance free.

Sitework

The frame is supplied factory fitted to an Em-Curb or Em-Collar. For mounting to builder's curb the frame will need to be supplied with an adaptor frame.

Fixing Em-Dome Plus to Em-Curb

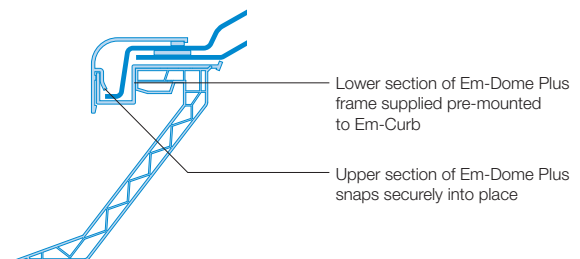

Burglar grid

Where a higher level of security is required a burglar bar grid is available for most sizes and permutations. Polyester powder coated frames are also available.

The grid provides extra strength to the complete installation whilst also acting as an extra visual deterrent to potential intruders.

Type of burglar bar grid varies according to size. Please consult Whitesales for exact details.

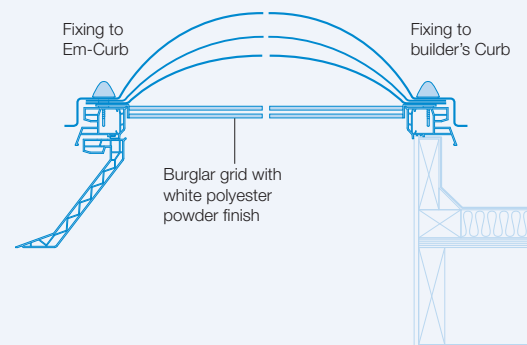

Access options

Features

- Rooflight becomes means of access to roof
- Can be installed to existing upstand with Em-Collar
- Em-Curb upstands can be incorporated
- Provides a safe access route
- Telescopic gas or friction struts
- Remote electric operation units available



Em-Dome in opal diffused with PVC 150mm splayed upstand and access hatch facility

Description

Where the rooflight is to be used as a means of access on to a roof the hinged access hatch frame opens to 90° to provide a safe route for personnel and equipment, often avoiding the need to provide other external facilities. The access frame can be specified for mounting either direct to a builder's curb with Em-Collar and T-Collar adaptors or in conjunction with Em-Curb upstands.

Standard features include a locking handle to secure the rooflight in the closed position and telescopic struts to hold the rooflight in the open position. The telescopic struts are either gas assisted hydraulic operation or have adjustable friction control and can be set according to dome weight and prevailing site conditions.

Limitations of use

Access hatches are not recommended in sizes larger than 1160mm square or 860 x 1460mm rectangular.

Other options

Remote electric operation opening units are also available (refer to Whitesales).

Refer to Whitesales dedicated brochure 'Smoke ventilation and access hatches'.

Access hatch – mounted to Em-Curb

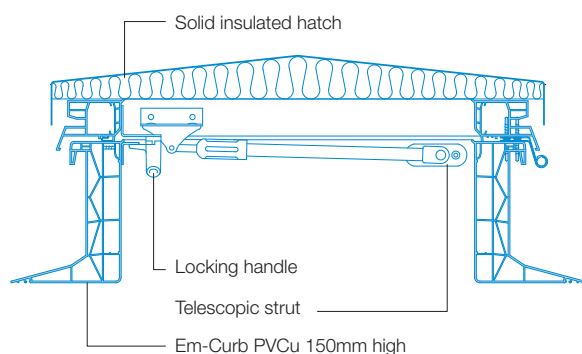

Access hatch – mounted to Em-Collar

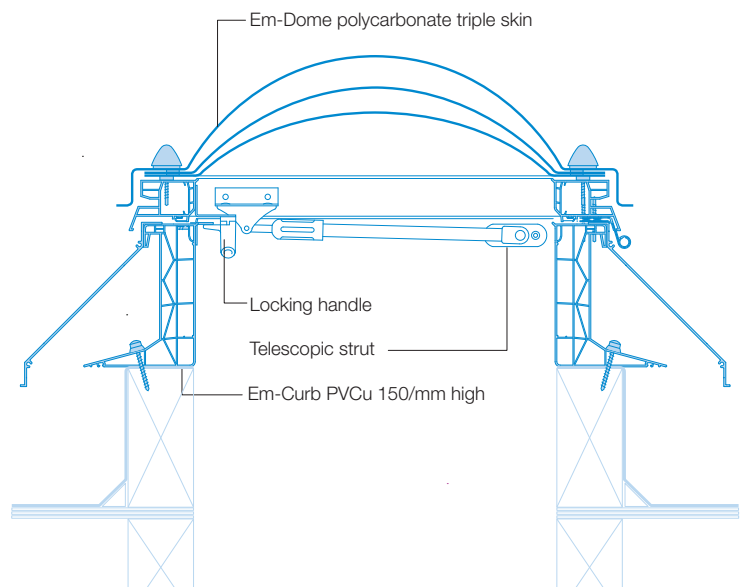

Smoke vent options

Features

- Rooflight provides light to stairwells
- Available with glazed or solid lid
- Open to 90° or 140°
- Can incorporate roof access facility
- Control pack with accessories available
- Stand alone Opening Vent (OV)
- Integrated Automatic Opening Vent (AOV)



Em-Vent solid cover AOVs polyester powder coated dark grey

Smoke vents

OVs (Opening Vents) and AOVs (Automatic Opening Vents) are required to meet the relevant Building Regulations for ventilating escape routes. The Regulations stipulate a minimum free ventilation area (normally 1.0m² or 1.5m²), and require units to open to either 90° or 140° depending on a number of factors. Ventilation areas can be achieved with a variety of square or rectangular Em-Domes and can be used in conjunction with Em-Curb upstands or T-Collar and Em-Collar adaptors.

Opening the rooflight is by means of a 24V DC electric actuator. For OVs we can provide a stand alone control panel with a comprehensive range of accessories – for AOVs our control panel can interface with the main Building Management System (BMS) or accessories. Due to the variety of BMSs that are required to satisfy the relevant authorities, we recommend that a qualified mechanical and electrical company is employed to plan and install the system.

Refer to Whitesales 'Smoke Ventilators and Access Hatches' brochure for full details.

Smoke vent – mounted to Em-Curb

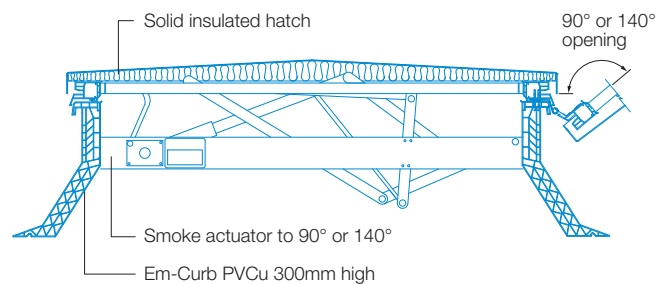

Smoke vent – mounted to Em-Collar

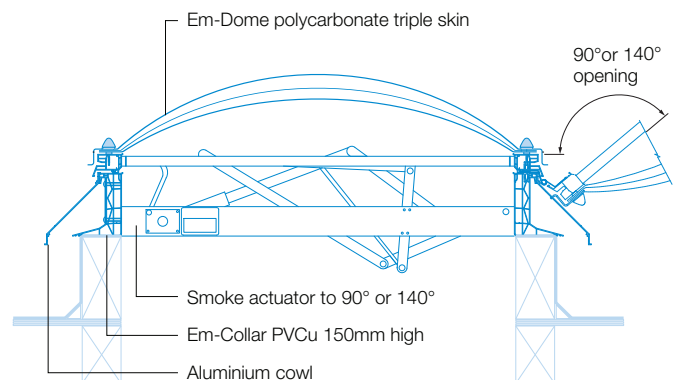



Case study	Royal Quays
Project type	New build
Products	Em-Vent Smoke Vents 90° Em-Hatch Access Hatches
Glazing	Triple glazed polycarbonate opal diffused finish
Upstand	Em-Curb PVC-u 300/s
Other	Double unit with central link and gutter detail

Ventilation options

Features

- Permanent Trickle
- Controllable Trickle
- Controllable Rotating
- Hinged Manual Spindle Opening
- Hinged Electric Actuator Opening
- Powered Extract Fan



Em-Dome in opal diffused with Em-Collar and hinged opener

Permanent Trickle

Permanent ventilation is provided by means of spacer washers inserted in the Em-Dome fixings. This provides a continuous 5 to 10mm weatherproof vent around the perimeter of the rooflight which suits areas such as corridors and other areas where non-controllable background ventilation is required.

Controllable Trickle

Controllable trickle ventilation is an adjustable slot vent which is fitted to two or four sides of a PVC Em-Curb, Em-Collar or T-Collar. With the vents on two sides the unit can provide 8000mm² ventilation area which assists with Building Regulations compliance.

Fitted to Em-Curb

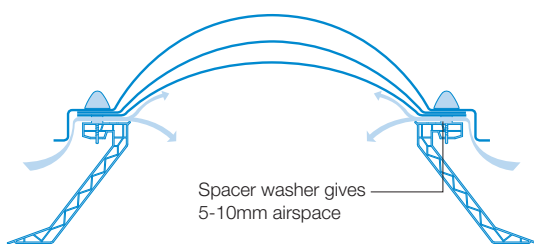

Fitted to Em-Curb

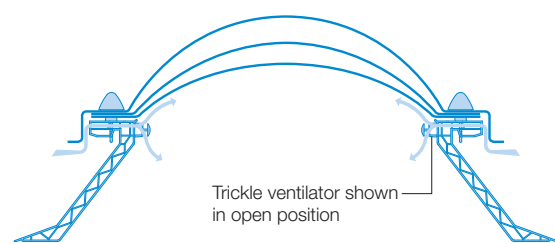

Fitted to builder's curb

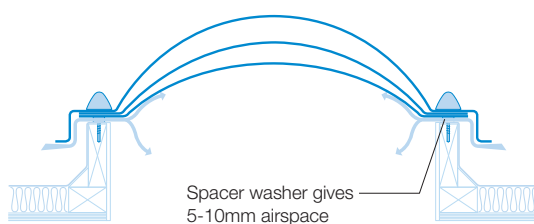

Fitted to builder's curb

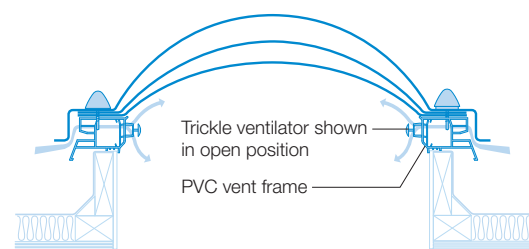

Em-Dome in HeatReflect finish with PVC 300mm upstand and rotating vents



Em-Dome in opal diffused with hinged opener and rotating vents

Controllable Rotating

Controllable rotating vents are a fully insulated unit with enhanced thermal properties and a greater vent area than the Trickle Vent options. The vents can be fitted to two or four sides of a PVC Em-Curb or Em-Collar. With the vents on two sides, the unit will provide a minimum of 11,000mm² ventilation area. This increases with the size of the rooflight. Tested and certified according to EN 1873 – Watertightness.

Fitted to Em-Curb

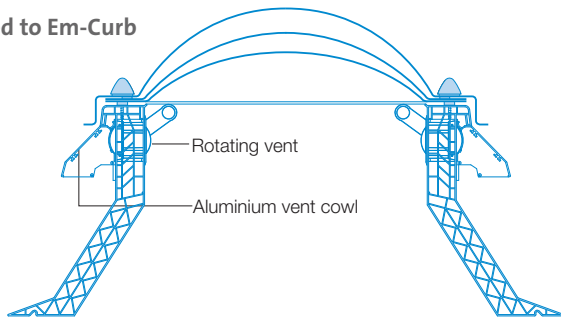

Hinged Manual Spindle Opening

Hinged opening vents provide the maximum ventilation area to allow rapid air movement. The manual spindle operation can be opened to any point up to 300mm and is operated by a Winding Rod available separately. Tested and certified according to EN 1873 – Watertightness.

Fitted to Em-Curb

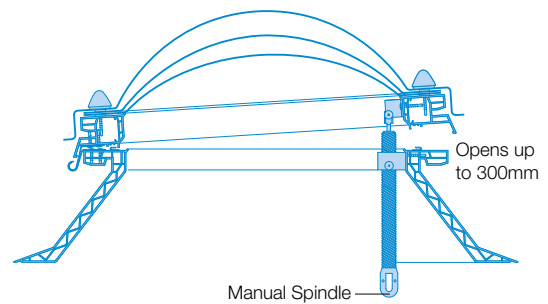

Fitted to Em-Collar

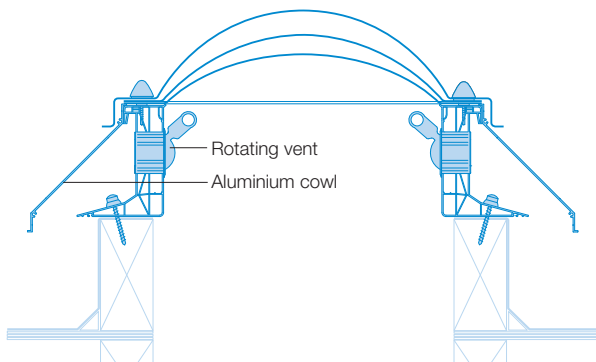

Fitted to builder's curb

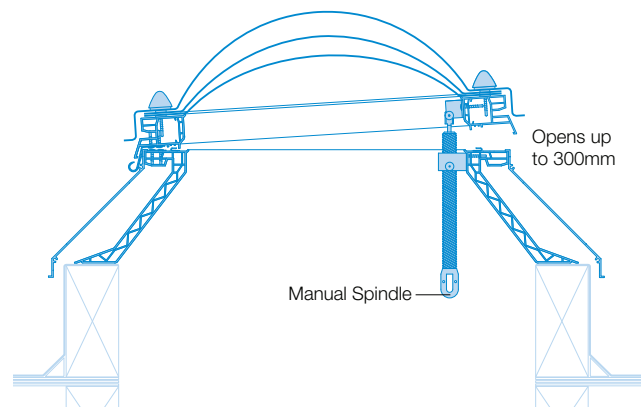

Ventilation options: continued

Em-Dome in clear with Em-Collar and electric hinged opener



Hinged Electric Actuator Opening

Hinged opening vents provide the maximum ventilation area to allow rapid air movement. The electric actuator operation allows control by a wall mounted open/close switch and also options for wind, rain and temperature sensors with a range of control panels available separately. Actuators are either 24V DC or 230V AC with options to open to 400 or 600mm.

Fitted to Em-Curb

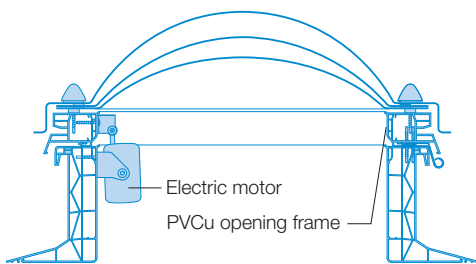

Fitted to Em-Collar

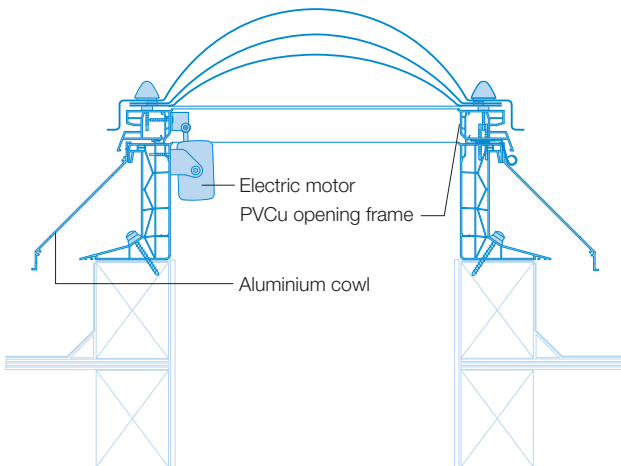

Powered ventilation

Where natural ventilation is insufficient, Em-Domes can be supplied with Vent Axia Solo or Centrif Duo centrifugal extract fans. These are mounted in the side wall of Em-Curb PVC-u 150/v or Em-Curb PVC-u 300/s.

These high performance extract fans are specifically designed for ventilating internal bathrooms, WCs and other small rooms. They have an extract performance of 85 m³/hr (24 l/s) or 220 m³/hr (61 l/s) respectively and can be fitted in one or more sides. Where greater air movement is required, white PVC lined fan collars with pre-cut apertures are available to enable fitting of larger axial fans (e.g. Vent-Axia T-series). This allows either new high capacity fans to be installed or existing fans to be reinstated through the rooflight unit.

Fitted to Em-Curb

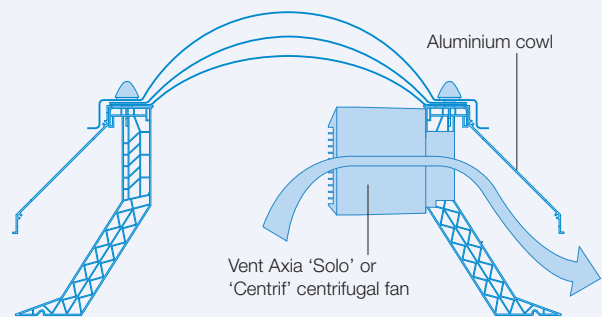

Fitted to Em-Collar

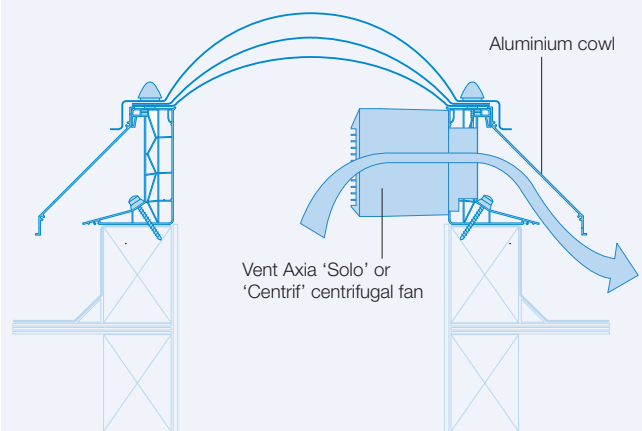

Ventilation controls

Controllers

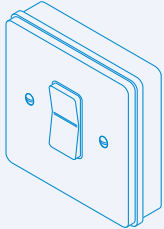

Open/Close

- Retractive switch – 240V as standard
- Surface mounted or flush
- Also available with transformer for 24V actuators
- Key switching available
- Waterproofing casing available

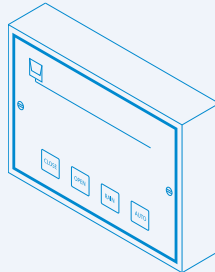

Control panel

- Includes open/close manual override switch
- Automated/controlled opening of actuators
- Opens electric actuator in conjunction with sensors shown below

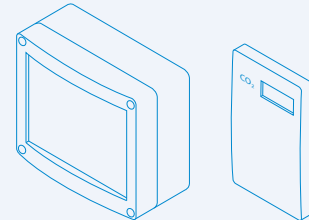

CO₂

- Monitors CO₂ concentration, indoor air quality to meet the requirement of Building Bulletin 101 – Ventilation in School Buildings – July 2005
- Traffic light system indicates CO₂ level range (green – optimum, yellow – moderate, red – poor)

Accessories/sensors

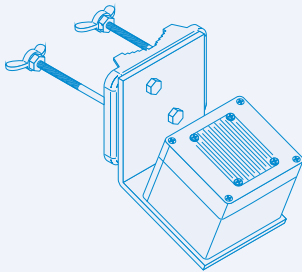

Rain detector

- Heated sensor area
- Rain signal stored for two minutes
- Includes mounting brackets

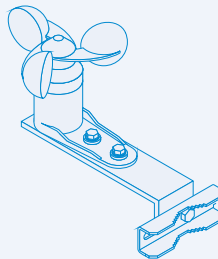

Wind sensor

- Aerial mast fastening
- Wind signal stored for ten minutes

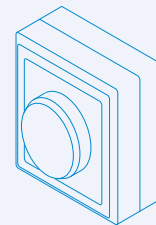

Humidity

- Ideal for washrooms, swimming pool areas and other high-humidity rooms

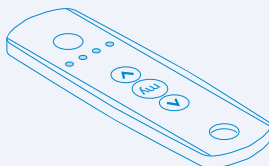

Remote

- Radio remote controller
- Choice of one or four channels
- Includes receiver and power pack

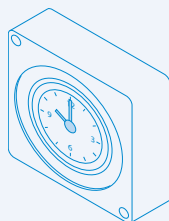

Timer

- Enable timer and set override – ideal for end of day closure
- Can be used for open and close functions

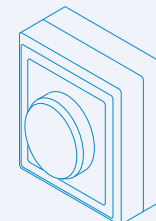

Thermostat

- Control high temperature levels
- Use in conjunction with timer for optimum effectiveness

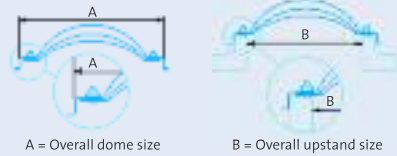

Em-Dome size chart

Em-Dome rooflights

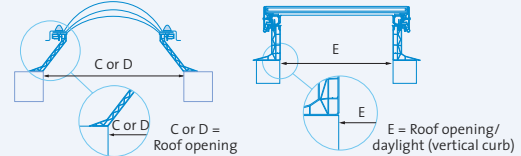

Em-Curb upstands



Em-Dome shape	Size Ref No.	Pyramid availability	ECO10 availability	Dimension A Overall dome size (mm)	Dimension B Overall upstand size (mm)	Dimension C Roof opening (PVC splayed curb) (mm)	Dimension D Roof opening (GRP curb) (mm)	Dimension E Roof opening (PVC vertical curb) (mm)
Square sizes 	S0		●	460 x 460	400 x 400	500 x 500	500 x 500	300 x 300
	S1	Δ	●	560 x 560	500 x 500	600 x 600	650 x 650	400 x 400
	S1A			610 x 610	550 x 550	650 x 650	N/A	450 x 450
	S2	Δ	●	660 x 660	600 x 600	700 x 700	750 x 750	500 x 500
	S3			710 x 710	650 x 650	750 x 750	750 x 750	550 x 550
	S4	Δ	●	760 x 760	700 x 700	800 x 800	850 x 850	600 x 600
	S5	Δ	●	860 x 860	800 x 800	900 x 900	950 x 950	700 x 700
	S6	Δ	●	910 x 910	850 x 850	950 x 950	1000 x 1000	750 x 750
	S7	Δ	●	960 x 960	900 x 900	1000 x 1000	1050 x 1050	800 x 800
	S7A			1010 x 1010	950 x 950	1050 x 1050	N/A	850 x 850
	S8	Δ	●	1060 x 1060	1000 x 1000	1100 x 1100	1150 x 1150	900 x 900
	S9	Δ	●	1160 x 1160	1100 x 1100	1200 x 1200	1250 x 1250	1000 x 1000
	S10			1210 x 1210	1150 x 1150	1250 x 1250	1250 x 1250	1050 x 1050
	S10A	Δ	●	1260 x 1260	1200 x 1200	1300 x 1300	N/A	1100 x 1100
	S11	Δ	●	1360 x 1360	1300 x 1300	1400 x 1400	1450 x 1450	1200 x 1200
	S12	Δ	●	1460 x 1460	1400 x 1400	1500 x 1500	1550 x 1550	1300 x 1300
	S13	Δ	●	1560 x 1560	1500 x 1500	1600 x 1600	1650 x 1650	1400 x 1400
S14	Δ		1660 x 1660	1600 x 1600	1700 x 1700	1750 x 1750	1500 x 1500	
S14A			1710 x 1710	1650 x 1650	1750 x 1750	N/A	1550 x 1550	
S15	Δ	●	1760 x 1760	1700 x 1700	1800 x 1800	1850 x 1850	1600 x 1600	
S15A	Δ		1860 x 1860	1800 x 1800	1900 x 1900	N/A	1700 x 1700	
S16	Δ		1960 x 1960	1900 x 1900	2000 x 2000	2050 x 2050	1800 x 1800	
S17	Δ		2160 x 2160	2100 x 2100	2200 x 2200	2250 x 2250	2000 x 2000	
Circular sizes 	C1			560 DIA	500 DIA	N/A	650 DIA	500 DIA
	C2			660 DIA	600 DIA	N/A	750 DIA	600 DIA
	C3			760 DIA	700 DIA	N/A	850 DIA	700 DIA
	C4			860 DIA	800 DIA	N/A	950 DIA	800 DIA
	C5			960 DIA	900 DIA	N/A	1050 DIA	900 DIA
	C6			1060 DIA	1000 DIA	N/A	1150 DIA	1000 DIA
	C7			1160 DIA	1100 DIA	N/A	1250 DIA	1100 DIA
	C8			1260 DIA	1200 DIA	N/A	1350 DIA	1200 DIA
	C8A			1360 DIA	1300 DIA	N/A	1450 DIA	1300 DIA
	C9			1460 DIA	1400 DIA	N/A	1550 DIA	1400 DIA
	C9A			1560 DIA	1500 DIA	N/A	N/A	1500 DIA
	C10			1760 DIA	1700 DIA	N/A	1850 DIA	1700 DIA
C10A			1860 DIA	1800 DIA	N/A	1950 DIA	1800 DIA	
C11			1960 DIA	1900 DIA	N/A	2050 DIA	1900 DIA	
C12			2160 DIA	2100 DIA	N/A	2250 DIA	2100 DIA	
Rectangular sizes 	R1			460 x 960	400 x 900	500 x 1000	500 x 1000	300 x 800
	R1A			460 x 1060	400 x 1000	500 x 1100	N/A	300 x 900
	R2			460 x 1460	400 x 1400	500 x 1500	500 x 1500	300 x 1300
	R3	Δ		560 x 860	500 x 800	600 x 900	650 x 950	400 x 700
	R3A	Δ		560 x 1160	500 x 1100	600 x 1200	650 x 1250	400 x 1000
	R3C			560 x 1460	500 x 1400	600 x 1500	N/A	400 x 1300
	R3CX			560 x 1660	500 x 1600	600 x 1700	N/A	400 x 1500
	R3D			560 x 1760	500 x 1700	600 x 1800	N/A	400 x 1600
	R3X			560 x 2060	500 x 2000	600 x 2100	N/A	400 x 1900
	R3Y			560 x 2360	500 x 2300	600 x 2400	N/A	400 x 2200
	R3Z			560 x 2960	500 x 2900	600 x 3000	N/A	400 x 2800
	R3P			610 x 910	550 x 850	650 x 950	N/A	450 x 750
	R3R			610 x 1210	550 x 1160	650 x 1250	N/A	450 x 1060
	R3			660 x 860	600 x 800	700 x 900	750 x 950	500 x 700
	R4	Δ		660 x 960	600 x 900	700 x 1000	N/A	500 x 800
	R4X			660 x 1160	600 x 1100	700 x 1200	750 x 1250	500 x 1000
	R4A	Δ		660 x 1260	600 x 1200	700 x 1300	N/A	500 x 1100
	R4Y			660 x 1560	600 x 1500	700 x 1600	N/A	500 x 1400
	R4B			660 x 1860	600 x 1800	700 x 1900	N/A	500 x 1700
	R4E			660 x 2160	600 x 2100	700 x 2200	N/A	500 x 2000
	R4Z			660 x 2460	600 x 2400	700 x 2500	N/A	500 x 2300
	R5X			760 x 960	700 x 900	800 x 1000	N/A	600 x 800
	R5	Δ		760 x 1060	700 x 1000	800 x 1100	850 x 1150	600 x 900
	R6	Δ		760 x 1360	700 x 1300	800 x 1400	850 x 1450	600 x 1200
R6A			760 x 1460	700 x 1400	800 x 1500	800 x 1500	600 x 1300	
R6C			760 x 1660	700 x 1600	800 x 1700	N/A	600 x 1500	
R6F			760 x 1960	700 x 1900	800 x 2000	N/A	600 x 1800	
R6G			760 x 2060	700 x 2000	800 x 2100	N/A	600 x 1900	
R6H			760 x 2160	700 x 2100	800 x 2200	N/A	600 x 2000	

Em-Dome rooflights

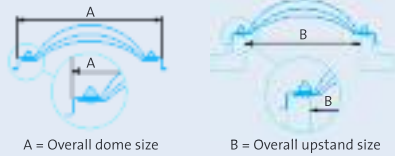

Em-Curb upstands

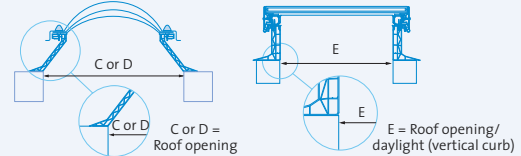

Em-Dome shape	Size Ref No.	Pyramid availability	ECO 10 availability	Dimension A Overall dome size (mm)	Dimension B Overall upstand size (mm)	Dimension C Roof opening (PVC splayed curb) (mm)	Dimension D Roof opening (GRP curb) (mm)	Dimension E Roof opening (PVC vertical curb) (mm)
Rectangular sizes (continued)	R7	△	●	860 x 1160	800 x 1100	900 x 1200	950 x 1250	700 x 1000
	R7A			860 x 1460	800 x 1400	900 x 1500	950 x 1500	700 x 1300
	R7b			860 x 1660	800 x 1600	900 x 1700	N/A	700 x 1500
	R7B			860 x 1760	800 x 1700	900 x 1800	N/A	700 x 1600
	R7x			860 x 2160	800 x 2100	900 x 2200	N/A	700 x 2000
	R7y			860 x 2360	800 x 2300	900 x 2400	N/A	700 x 2200
	R8x			910 x 1210	850 x 1150	950 x 1250	N/A	750 x 1050
	R8	△		910 x 1410	850 x 1350	950 x 1450	1000 x 1500	750 x 1250
	R9x			910 x 1810	850 x 1750	950 x 1850	N/A	750 x 1650
	R9	△		910 x 1910	850 x 1850	950 x 1950	1000 x 2000	750 x 1750
	R10			910 x 2410	850 x 2350	950 x 2450	1000 x 2500	750 x 2250
	R10A	△		960 x 1260	900 x 1200	1000 x 1300	N/A	800 x 1100
	R11	△	●	960 x 1460	900 x 1400	1000 x 1500	1050 1550	800 x 1300
	R11x			960 x 1560	900 x 1500	1000 x 1600	N/A	800 x 1400
	R11c			960 x 1760	900 x 1700	1000 x 1800	N/A	800 x 1600
	R11A			960 x 1860	900 x 1800	1000 x 1900	N/A	800 x 1700
	R12	△		960 x 1960	900 x 1900	1000 x 2000	1000 x 2000	800 x 1800
	R12B			960 x 2160	900 x 2100	1000 x 2200	N/A	800 x 2000
	R13			960 x 2360	900 x 2300	1000 x 2400	1050 x 2450	800 x 2200
	R14			960 x 2460	900 x 2400	1000 x 2500	1000 x 2500	800 x 2300
	R14A			960 x 2660	900 x 2600	1000 x 2700	N/A	800 x 2500
	R15			960 x 2960	900 x 2900	1000 x 3000	1000 x 3000	800 x 2800
	R15m			1010 x 2510	950 x 2450	1050 x 2550	N/A	850 x 2350
	R16			1060 x 1360	1000 x 1300	1100 x 1400	1150 x 1450	900 x 1200
	R16A			1060 x 1660	1000 x 1600	1100 x 1700	1150 x 1750	900 x 1500
	R16B			1060 x 1960	1000 x 1900	1100 x 2000	1150 x 2050	900 x 1800
	R16E			1060 x 2260	1000 x 2200	1100 x 2300	N/A	900 x 2100
	R17	△	●	1160 x 1460	1100 x 1400	1200 x 1500	1250 x 1550	1000 x 1300
	R17A			1160 x 1660	1100 x 1600	1200 x 1700	N/A	1000 x 1500
	R18	△	●	1160 x 1760	1100 x 1700	1200 x 1800	1250 x 1850	1000 x 1600
	R18A			1160 x 2060	1100 x 2000	1200 x 2100	1250 x 2150	1000 x 1900
	R19	△	●	1160 x 2160	1100 x 2100	1200 x 2200	1250 x 2250	1000 x 2000
	R20	△		1160 x 2360	1100 x 2300	1200 x 2400	1250 x 2450	1000 x 2200
	R21			1160 x 2460	1100 x 2400	1200 x 2500	1250 x 2550	1000 x 2300
	R22			1160 x 2660	1100 x 2600	1200 x 2700	1250 x 2750	1000 x 2500
R22A			1160 x 2960	1100 x 2900	1200 x 3000	N/A	1000 x 2800	
R22z			1160 x 3160	1100 x 3100	1200 x 3200	N/A	1000 x 3000	
R22P			1210 x 1810	1150 x 1750	1250 x 1850	N/A	1050 x 1650	
R22r			1210 x 2410	1150 x 2350	1250 x 2450	N/A	1050 x 2250	
R22x			1260 x 1560	1200 x 1500	1300 x 1600	N/A	1100 x 1400	
R22B	△		1260 x 1860	1200 x 1800	1300 x 1900	N/A	1100 x 1700	
R22c			1260 x 2460	1200 x 2400	1300 x 2500	N/A	1100 x 2300	
R23w			1360 x 1560	1300 x 1500	1400 x 1600	N/A	1200 x 1400	
R23x			1360 x 1660	1300 x 1600	1400 x 1700	1450 x 1750	1200 x 1500	
R23			1360 x 1960	1300 x 1900	1400 x 2000	1450 x 2050	1200 x 1800	
R23A			1360 x 2260	1300 x 2200	1400 x 2300	1450 x 2350	1200 x 2100	
R23B			1360 x 2560	1300 x 2500	1400 x 2600	N/A	1200 x 2400	
R24			1460 x 1760	1400 x 1700	1500 x 1800	1550 x 1850	1300 x 1600	
R25			1460 x 2060	1400 x 2000	1500 x 2100	1550 x 2150	1300 x 1900	
R26			1460 x 2160	1400 x 2100	1500 x 2200	1550 x 2250	1300 x 2000	
R27			1460 x 2360	1400 x 2300	1500 x 2400	1550 x 2450	1300 x 2200	
R28	△		1460 x 2460	1400 x 2400	1500 x 2500	1550 x 2550	1300 x 2300	
R29			1460 x 2660	1400 x 2600	1500 x 2700	1550 x 2750	1300 x 2500	
R30			1460 x 2960	1400 x 2900	1500 x 3000	1550 x 3050	1300 x 2800	
R31x			1760 x 2060	1700 x 2000	1800 x 2100	1850 x 2150	1600 x 1900	
R31			1760 x 2160	1700 x 2100	1800 x 2200	1850 x 2250	1600 x 2000	
R32			1760 x 2360	1700 x 2300	1800 x 2400	1850 x 2450	1600 x 2200	
R32A			1760 x 2460	1700 x 2400	1800 x 2500	1850 x 2550	1600 x 2300	
R33			1760 x 2660	1700 x 2600	1800 x 2700	1850 x 2750	1600 x 2500	
R34			1760 x 2960	1700 x 2900	1800 x 3000	1850 x 3050	1600 x 2800	
R35			1960 x 2960	1900 x 2900	2000 x 3000	N/A	1800 x 2800	



How to specify checklist

Use the following checklist to help you consider the elements that need to be specified for your project and the Whitesales team will help you to apply this to a full specification.

1 Select shape of rooflight (see page 8)



2 Take site measurements or choose ideal size (see page 39)

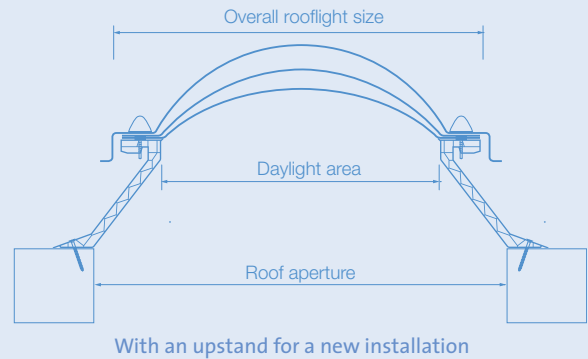

3 Select curb (see pages 10-11)

With an upstand for a new installation

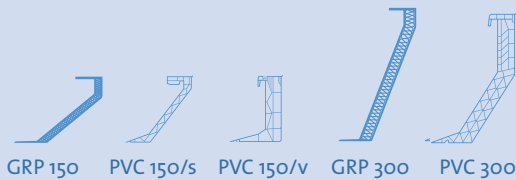

With a curb adaptor to fit an existing upstand

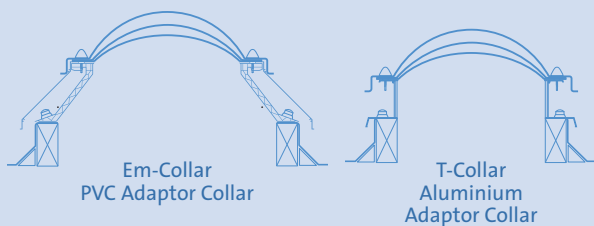

With a PVC upstand to oversleeve an existing upstand

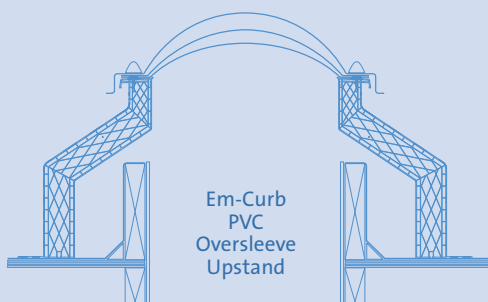

4 Select glazing (see page 8)

Profile



Type

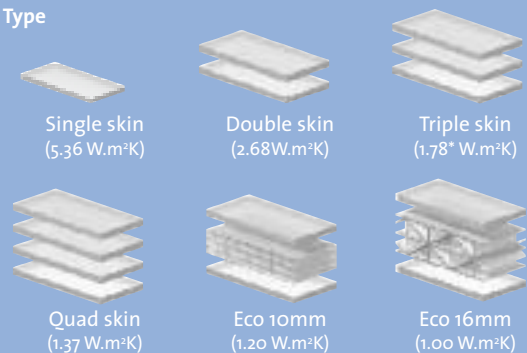

Finish



* Measured in hot box in the vertical BS EN ISO 12567-2: 2005

“ With over 140 sizes,
ranging from 300 x 300mm to 1800 x 3000mm,
we provide you with the largest selection
to choose from in the UK. ”

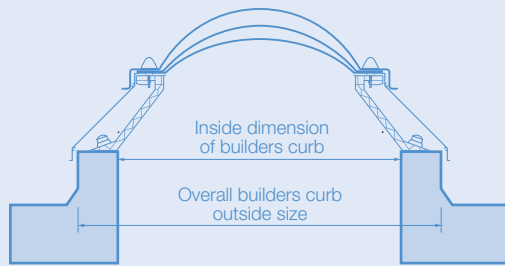

With a curb adaptor to fit an existing upstand

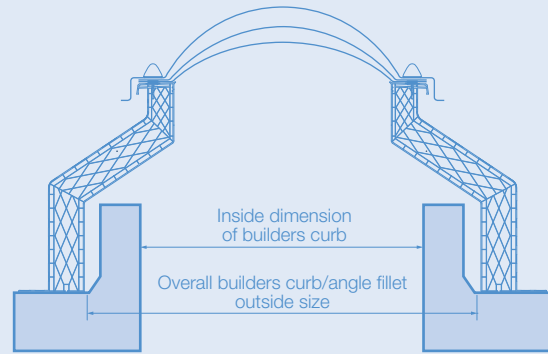

With a PVC upstand to oversleeve an existing upstand

5 Select ventilation and opening options (see pages 13, 16-18)

Permanent Trickle Vent

Permanent non-controllable spacer washers for corridors and non-inhabited rooms.

Controllable Trickle Vent

Controllable slot ventilator on two or four sides. Provides minimum 8000mm² vent to assist compliance with Building Regulations.

Controllable Rotating Vent

Fully insulated controllable vent for secure and effective through flow of air. Suited to living and working areas.

Hinged Manual Opener

Hinged opener controlled by operating rod. Provides high air movement and can be opened up to 300mm.

Hinged Electric Opener

Electrically operated hinged opener operated by switch of specialist control pack. Opens up to either 400 or 600mm.

Extract Fan

Centrifugal extract fan to remove air. Suited to cloakroom, kitchen and other high humidity areas

Smoke Vent

Electrically operated hinged openers to allow controlled smoke ventilation. Open to either 90° or 140°.

Access Hatch

Hinged and lockable access hatch to allow safe access to roof or plant areas.

6 Other options (see page 12)

Specify from product literature

e.g. Burglar bar grid, Security frame.

Typical NBS clause

L10 – Windows / Rooflights / Screens / Louvres

460 – Rooflights

Manufacturer: Whitesales – Tel + 44 (0)1483 271371,
E-mail sales@whitesales.co.uk, Web www.whitesales.co.uk

Product Reference: Em-Dome Thermoformed Modular Rooflight

Type: [Rectangular] [Square] [Circular]

Size: [Specify from Product literature or Consult Whitesales]

Frame: High Security Screwbolt

Kerb: [Specify upstand height and type, or curb adaptor type]

Glazing details:

Material: Polycarbonate

Profile: [Dome] [Pyramid] [Trapezoidal]

Type: [single] [double] [triple] [quad] [multiwall] skin

Finish: [Clear] [Opal Diffused] [Bronze] [Heat-Reflect]

Ventilation and opening: [Permanent] [Controllable Trickle] [Rotating] [Manual hinged opener] [Electric hinged opener] [Extract Fan] [Smoke Vent] [Access Hatch]

Other requirements: [Burglar Bar Grid]

Fixing: [Consult Whitesales for recommendations]

Em-Glaze™

High quality, aesthetically pleasing prefabricated flat glass rooflights. Em-Glaze Modular units are available in a wide range of standard sizes or can be made to measure and can also be colour coated to match other roof components if required.



Em-Glaze Modular with insulated T-Collar



Em-Glaze Modular to builder's upstand

Description

Em-Glaze Modular rooflights are designed to maximise the amount of natural daylight in a building and at the same time provide a clean minimalistic finish both inside and outside. They are manufactured with flat sealed glass units and incorporate a fully welded aluminium frame and cill detail. All visible aluminium is polyester powder coated light grey as standard.

The flush design ensures efficient drainage of rainwater and the silkprint edge ensures that the double glazed unit holds the unrivalled insulation value over the full lifetime without deterioration.

Performance

Thermal regulations

The double glazed unit exceeds current thermal requirements and the triple glazed unit gives an industry leading performance.

Sound reduction

With glass panes each at 6-8mm thick and a 16mm argon filled cavity the sound reduction will give excellent protection from traffic or other noise.

Installation

As the units are supplied prefabricated and assembled they are very simple to fix, either to a site formed upstand or to one of our PVC proprietary Em-Curbs.

Certification

Impact resistant to CWCT Class 2.

Em-Glaze key features

- 1 Factory pre-glazed
- 2 Secure, welded glazing frame
- 3 Em-Curb upstand provides tidy detailing
- 4 Ventilation options available
- 5 Good thermal and sound insulation properties



Flat glazed description

Features

- Prefabricated
- Simple to Install
- Flush design
- Unrivalled insulation value
- Ventilation options
- Low E argon filled sealed units



Em-Glaze Modular to builder's upstand

Glazing types

Double glazed Em-Glaze modular rooflights are manufactured with 32mm hermetically sealed Low E, argon filled units as standard, with a warm edge spacer, providing a high performance system. Solar control and self cleaning glass options are available.



Double glazed

Triple glazed

Size

Offered in a range of standard sizes some of which are stocked ready for immediate dispatch. Other non-standard sizes are available to order.

Testing

Requirement	Result	Classification
Watertightness	Passed	EN1873
Air tightness	Class 4 (60opa)	EN12207/EN1026
Sound insulation	34 R _w dB	DS/EN717-1/A1
Light transmission	86%	-
Weight	55 kg/m ²	-
Thermal insulation with upstand PVC-u 150V	1.24 W/m ² K	EN/ISO 10077-1 EN/ISO 10077-2 EN673 DS418
Impact	Class 2	CWCT

Above is for double glazed units

Thermal transmission

Values shown below are the calculated U-value, unless denoted otherwise. Complete unit U-values are available on request.

Glazing type	U-value (W/m ² K)
Double glazed with curb	1.24
Triple glazed with curb	0.87

Shapes

Em-Glaze Modular units are available in square and rectangular shapes. A selection of circular sizes is also available.



Square

Circular

Rectangular

Installation

Em-Glaze Modular rooflights can be supplied with the Em-Curb range of PVC upstands, or be installed to a builder's upstand. For both options, the upstand must be set at a slope of between 5° and 15°.



Case study Stratton Street
Project type Extension
Products Em-Glaze Modular
Glazing Double glazed glass
Upstand T-Collar upstand adaptor
Ventilation Electrically operated hinged opener

Flat glazed curbs

Features

- Used in conjunction with Em-Glaze rooflights
- Exceptional thermal efficiency
- Em-Curbs for new installations
- Em-Collars for replacement of existing
- Enhance overall appearance of the rooflight
- Prefinished white internally
- Heights available 150, 300 and 350mm



Em-Glaze Modular to PVC upstand with white polyester powder coated frame

Em-Curbs

Em-Curbs are designed to be used in conjunction with Em-Glaze Modular rooflights and are finished in white internally. Em-Curbs represent excellent value for money and enhance the overall appearance of the rooflight. The heights of Em-Curbs are 150, 300 and 350mm. The standard Em-Curb is made from extruded white PVC-u. The multi-chambered construction gives an exceptionally robust and thermally efficient performance. This curb is suitable for most roof finishes.

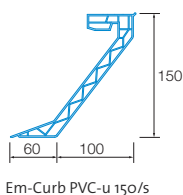

Em-Curb PVC-u 150/s

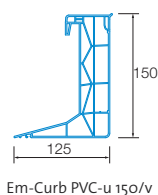

Em-Curb PVC-u 150/v

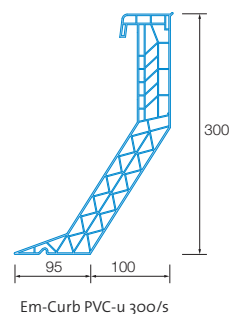

Em-Curb PVC-u 300/s

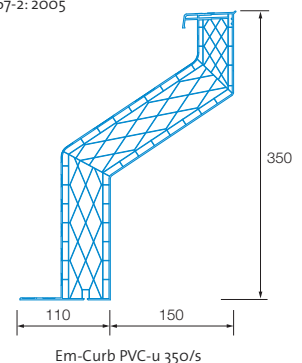

Em-Curb PVC-u 350/s

Thermal transmission

Typical values

U-value (W/m²K)

Em-Curb PVC-u 150/s	2.20
Em-Curb PVC-u 150/v	1.00*
Em-Curb PVC-u 300/s	1.00*
Em-Curb PVC-u 350/s	0.89

* Measured in hot box in the vertical BS EN ISO 12567-2: 2005

Em-Collars

Em-Collars provide a thermally broken solution for replacing existing rooflights and would typically be installed to an existing or newly formed builder's upstand where the dimensions do not suit a standard sized Em-Glaze Modular rooflight.

Em-Collar PVC Adaptor Collar

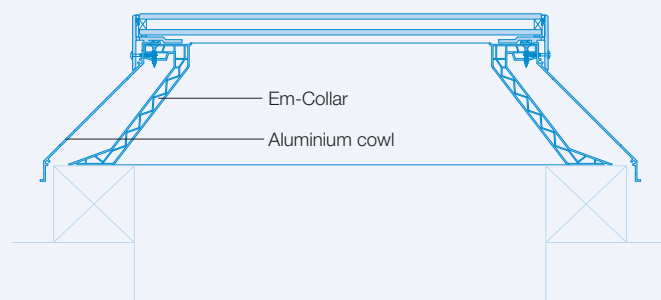

Flat glazed ventilation

Features

- Controllable Trickle
- Controllable Rotating
- Hinged Manual Spindle Opening
- Hinged Electric Actuator Opening

Controllable Trickle

Controllable trickle ventilation is a slot vent which is fitted to two or four sides of a PVC Em-Curb, Em-Collar or T-Collar. With the vents on two sides the unit will provide 8000mm² ventilation area which assists with Building Regulation compliance.

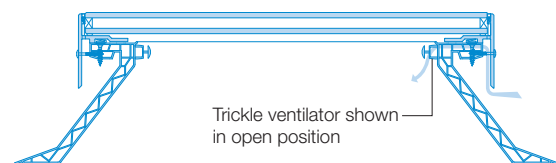

Controllable Rotating

Controllable rotating vents are a fully insulated unit with enhanced thermal properties and a greater vent area than the Trickle Vent options. The vents can be fitted to two or four sides of a PVC Em-Curb or Em-Collar. All units are supplied with external weathering cowls.

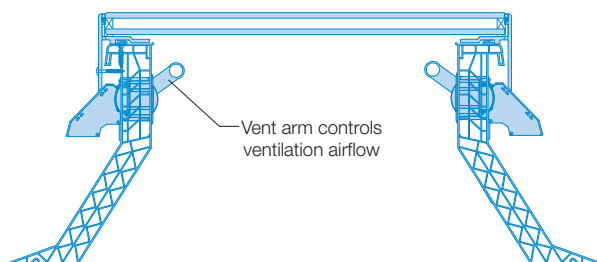

Hinged Manual Spindle Opening

Hinged opening vents provide the maximum ventilation area to allow rapid air movement. The manual spindle operation can be opened to any point up to 300mm and is operated by a 1.5, 2.0 or 3.0m winding rod available separately. For units larger than 1 x 1 m, the electrically operated hinged opener should be used.

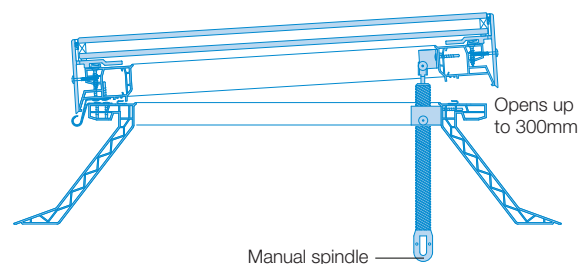

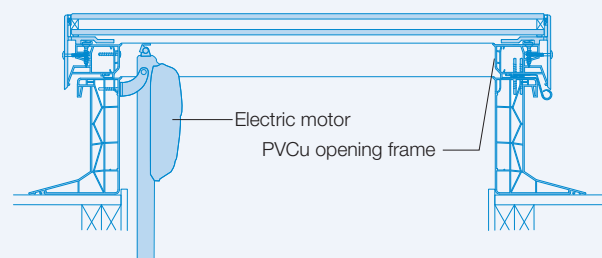

Hinged Electric Spindle Opening

Hinged opening vents provide the maximum ventilation area to allow rapid air movement. The electric actuator operation allows control by a wall mounted open/close switch and also options for wind, rain and temperature sensors with a range of control panels available separately. Actuators are either 24V DC or 230V AC and open to 180mm.



Em-Glaze size chart

Em-Glaze shape	Em-Glaze rooflights			Em-Curb upstands		
	Size Ref No.	Dimension A Overall glazing size (mm)	Dimension B Overall curb size (mm)	Dimension C Roof opening (PVC splayed curb) (mm)	Dimension E Roof opening (PVC vertical curb) (mm)	
Square sizes 	EG S2	640 x 640	600 x 600	700 x 700	500 x 500	
	EG S4	740 x 740	700 x 700	800 x 800	600 x 600	
	EG S5	840 x 840	800 x 800	900 x 900	700 x 700	
	EG S7	940 x 940	900 x 900	1000 x 1000	800 x 800	
	EG S8	1040 x 1040	1000 x 1000	1100 x 1100	900 x 900	
	EG S9	1140 x 1140	1100 x 1100	1200 x 1200	1000 x 1000	
	EG S10A	1240 x 1240	1200 x 1200	1300 x 1300	1100 x 1100	
	EG S11	1340 x 1340	1300 x 1300	1400 x 1400	1200 x 1200	
	EG S12	1440 x 1440	1400 x 1400	1500 x 1500	1300 x 1300	
	Rectangular sizes 	EG R3B	640 x 840	600 x 800	700 x 900	500 x 700
		EG R4	640 x 940	600 x 900	700 x 1000	500 x 800
		EG R4W	640 x 1040	600 x 1000	700 x 1100	500 x 900
EG R4A		640 x 1240	600 x 1200	700 x 1300	500 x 1100	
EG R4Y		640 x 1540	600 x 1500	700 x 1600	500 x 1400	
EG R4B		640 x 1840	600 x 1800	700 x 1900	500 x 1700	
EG R4F		640 x 2040	600 x 2000	700 x 2100	500 x 1900	
EG R5		740 x 1040	700 x 1000	800 x 1100	600 x 900	
EG R5A		740 x 1240	700 x 1200	800 x 1300	600 x 1100	
EG R6		740 x 1340	700 x 1300	800 x 1400	600 x 1200	
EG R6A		740 x 1440	700 x 1400	800 x 1500	600 x 1300	
EG R6C		740 x 1640	700 x 1600	800 x 1700	600 x 1500	
EG R6F		740 x 1940	700 x 1900	800 x 2000	600 x 1800	
EG R6G		740 x 2040	700 x 2000	800 x 2100	600 x 1900	
EG R6H		740 x 2140	700 x 2100	800 x 2200	600 x 2000	
EG R7C		840 x 1040	800 x 1000	900 x 1100	700 x 900	
EG R7E		840 x 1240	800 x 1200	900 x 1300	700 x 1100	
EG R7A		840 x 1440	800 x 1400	900 x 1500	700 x 1300	
EG R7F		840 x 1540	800 x 1500	900 x 1600	700 x 1400	
EG R7D		840 x 1640	800 x 1600	900 x 1700	700 x 1500	
EG R7B		840 x 1740	800 x 1700	900 x 1800	700 x 1600	
EG R7W		840 x 2040	800 x 2000	900 x 2100	700 x 1900	
EG R10A		940 x 1240	900 x 1200	1000 x 1300	800 x 1100	
EG R11		940 x 1440	900 x 1400	1000 x 1500	800 x 1300	
EG R11X		940 x 1540	900 x 1500	1000 x 1600	800 x 1400	
EG R11Y		940 x 1640	900 x 1600	1000 x 1700	800 x 1500	
EG R11C		940 x 1740	900 x 1700	1000 x 1800	800 x 1600	
EG R11A		940 x 1840	900 x 1800	1000 x 1900	800 x 1700	
EG R12A		940 x 2040	900 x 2000	1000 x 2100	800 x 1900	
EG R12B		940 x 2140	900 x 2100	1000 x 2200	800 x 2000	
EG R16C		1040 x 1240	1000 x 1200	1100 x 1300	900 x 1100	
EG R16		1040 x 1340	1000 x 1300	1100 x 1400	900 x 1200	
EG R16D	1040 x 1540	1000 x 1500	1100 x 1600	900 x 1400		
EG R16A	1040 x 1640	1000 x 1600	1100 x 1700	900 x 1500		
EG R16B	1040 x 1940	1000 x 1900	1100 x 2000	900 x 1800		
EG R16F	1040 x 2040	1000 x 2000	1100 x 2100	900 x 1900		
EG R17	1140 x 1440	1100 x 1400	1200 x 1500	1000 x 1300		
EG R17A	1140 x 1640	1100 x 1600	1200 x 1700	1000 x 1500		
EG R18	1140 x 1740	1100 x 1700	1200 x 1800	1000 x 1600		
EG R18A	1140 x 2040	1100 x 2000	1200 x 2100	1000 x 1900		
EG R19	1140 x 2140	1100 x 2100	1200 x 2200	1000 x 2000		
EG R22X	1240 x 1540	1200 x 1500	1300 x 1600	1100 x 1400		
EG R22B	1240 x 1840	1200 x 1800	1300 x 1900	1100 x 1700		
EG R22D	1240 x 2040	1200 x 2000	1300 x 2100	1100 x 1900		

Other sizes and circular units are available on request.



Case study Royal Military Academy

Project type Refurbishment

Products Em-Glaze Modular
Em-Curb

Glazing Double glazed glass

Upstand PVC-u 150

Ventilation Manually operated
hinged opener



Em-Tube™

Em-Tube Tubular Skylights effectively transmit natural daylight to internal rooms or areas that do not receive adequate daylight. Natural daylight is captured at roof level and directed downwards through rigid or flexible tubes and then diffused at ceiling level.



Em-Tube with PVC 150mm upstand on flat roof



Before Em-Tube installation



After Em-Tube installation

Flat and pitched roof tubular skylights

Many buildings suffer from low levels of daylight. Occupants and workers in all types of building, e.g. residential and commercial buildings, schools and hospitals all benefit from increased levels of natural daylight.

Natural daylight in buildings reduces energy demand and provides the full colour spectrum, thus reducing eyestrain, improving concentration and increasing productivity.

Em-Tube is an innovative and effective means of transmitting natural daylight to otherwise poorly lit areas and with the ventilation options available the units can assist compliance with Building Regulations.

The skylights can be installed into new or existing roofs with ease and can be accommodated within most roof construction types.

How much light does Em-Tube transmit?

Tests carried out in the UK prove that anything up to fourteen times the equivalent of a 100 watt bulb can be achieved with 3m of flexible Em-Tube run on the 550mm diameter unit.

Light intensity at three times during one day

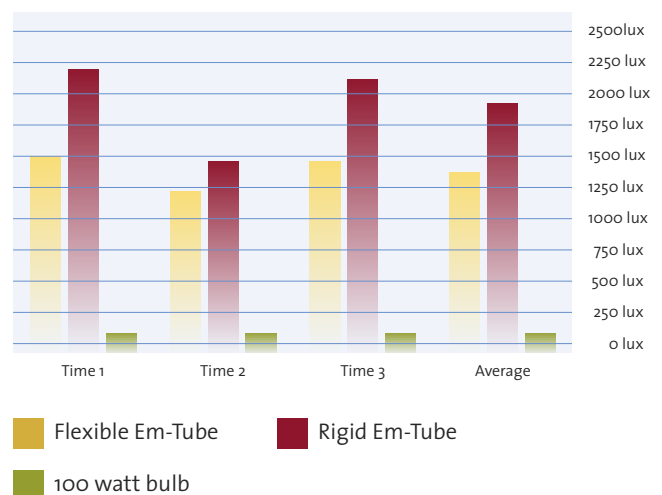

Em-Tube key features

- 1 Low profile UV protected polycarbonate dome
- 2 Ventilation option
- 3 Flexible and rigid tube options
- 4 Lower tube ceiling mounting ring
- 5 Easy-fit magnetic, double glazed ceiling diffuser
- 6 Roof flashing panel

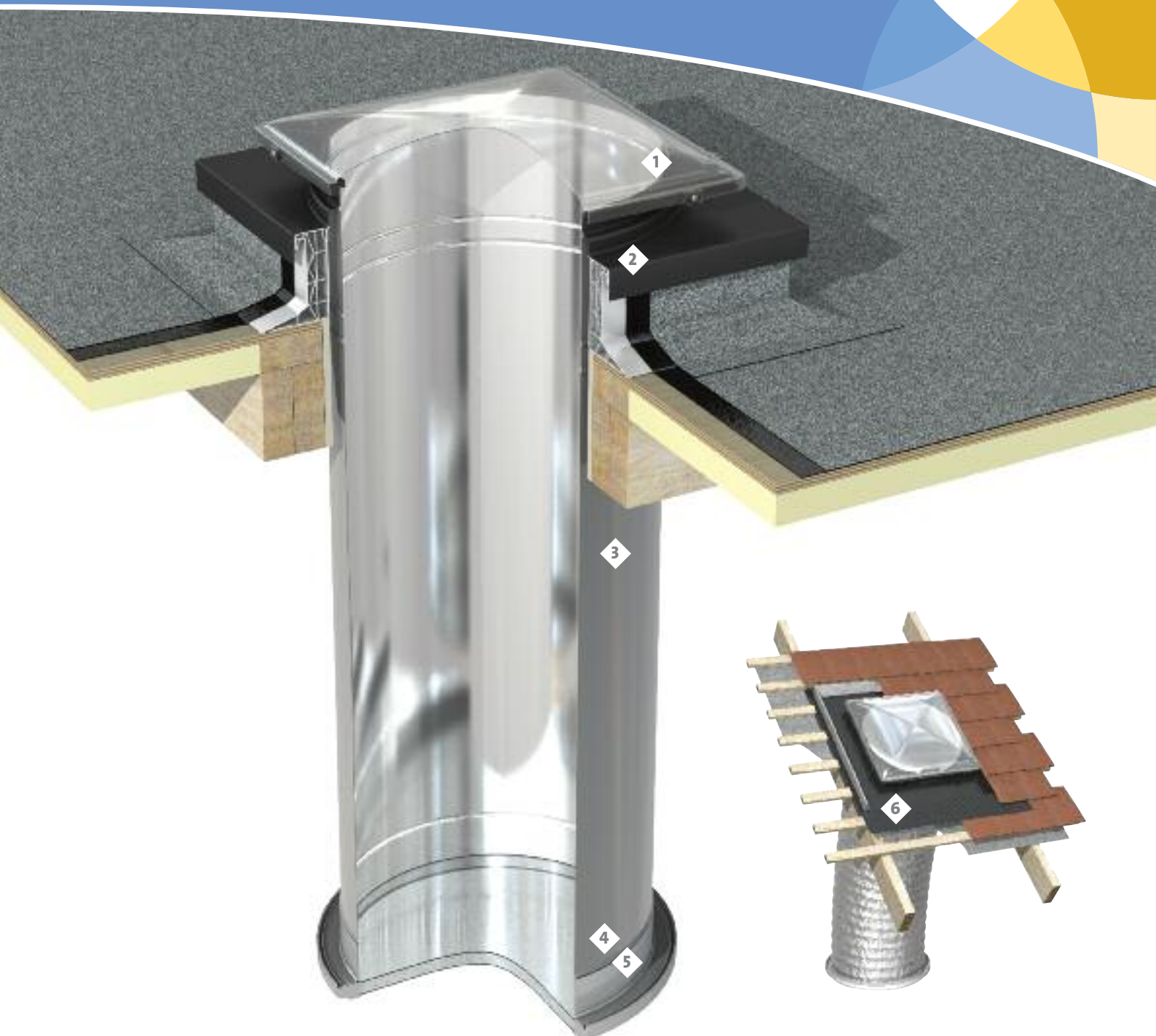

Em-Tube: Technical data

Features

- Up to 20 times more light than a 100w bulb
- Minimal disturbance to roof and ceiling
- Comprehensive range of sizes and accessories
- Double glazed ceiling diffuser
- Low profile polycarbonate UV resistant dome
- Flat, tile and slate roof options available



Em-Tube with PVC 150mm upstand on flat roof

Description

Em-Tube is an innovative and effective means of transmitting natural daylight to otherwise poorly lit areas. A passive ventilation system is included as a standard option and is available in rigid and flexible tube systems.

Rigid tube system

Offers 98% reflection on inner surface. Up to 20 times more light (2200 lux) than a 100w bulb (105 lux). Suitable for longer tube lengths.

Flexible tube system

Provides up to 14 times more light (1500 lux) than a 100w bulb (105 lux). Suitable for shorter tube length and is easier to install.

Availability

Standard units	350	450	550
Tile roof	✓	✓	✓
Slate roof	✓	✓	✓
Flat roof	✓	✓	✓

Optional accessories	350	450	550
Twin-skin diffuser	✓	✓	✓
Electric light	✓	✓	✓
PVC upstand for flat roofs	✓	✓	✓

It is recommended that all tubular skylight tubes are lagged with insulation to minimise the risk of condensation.

Applications and limitations of use

For maximum daylight output the Em-Tube should be located on a south facing roof slope and/or as high as possible, out of any shadow of tall trees and buildings. It should also be installed to give the most direct run from roof to ceiling level.

No specific level of light transmission can be guaranteed because specific applications and external light conditions are beyond our control.

Pitched roofs

Tile Flashing Kits are available to suit plain/profiled tiles or slates:

Tile/slate thickness	Flashing kit
8 to 16mm	'Slate Roof' kit
14 to 32mm	'Tile Roof' kit

Flat roofs

Whitesales recommends using Flat Roof Flashing Kits and installing to a PVC-u Em-Curb.

Size

Each Standard Em-Tube kit accommodates Rigid Tube System: up to 1.0m (0.7m for flat roof kits), Flexible Tube System: up to 3.0m.

625mm and 1250mm extension pieces are available in rigid tube – these are suitable for extending the Flexible and Rigid Tube Systems.

Flexible extension tubing is also available. Please consult Whitesales for advice on optimum permutations and application.

Em-Tube sizes

Nominal size (diameter)	Space needed between joists or rafters	Max. room size		Features
		Flexible tube	Rigid tube	
350mm	345mm	2 x 2m	3 x 3m	Suitable for very small rooms. Fits between most conventional rafters/joists, eliminating need for trimming work.
450mm	460mm	3.5 x 3.5m	4.5 x 4.5m	Suitable for bathrooms, hallways, landings, or corridors.
550mm	540mm	5 x 5m	6 x 6m	Suitable for living areas, kitchens, large landing, corridors, offices, retail areas or commercial areas.

For larger areas, use multiple units of optimum permutation. Transmitted light varies due to position on roof and adjacent trees or buildings.

Accessories

Em-Curb upstand for flat roof applications

- ◆ Economical and effective alternative to builder's upstand curb
- ◆ Compatible with most flat roof finishes
- ◆ Extruded PVCu
- ◆ 150mm high

Em-Tube fire collar

- ◆ Mounted above ceiling diffuser
- ◆ Protects against fire spread
- ◆ Certified up to four hours' fire protection

Em-Tube light kit

- ◆ Provides 24hrs single light source – no need for separate light fitting
- ◆ 240V 60watt
- ◆ Specially designed for Em-Tubes
- ◆ Cost effective

Em-Tube security collar

- ◆ Intruder resistant grid

Typical installation details

Pitched roof

Tile flashing kits are available to suit plain/profiled tiles or slates.

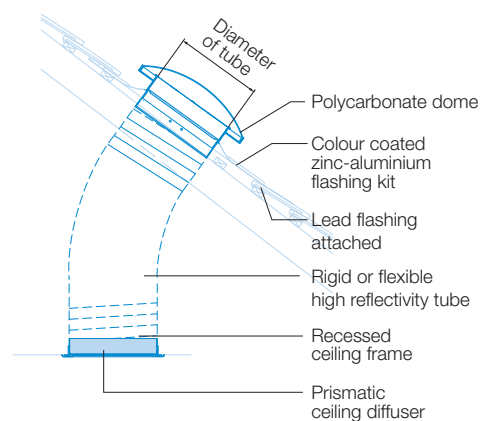

Flat roof

For installation to a timber builder's curb or PVCu upstand, use flat roof flashing kit.

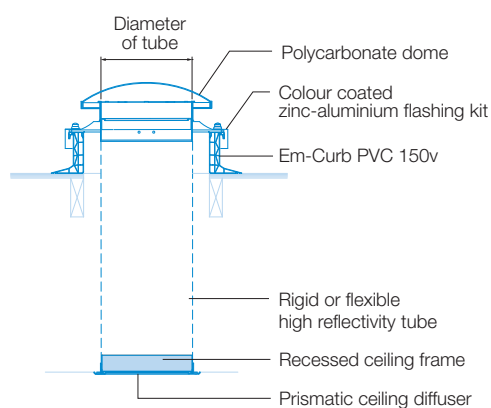

Design considerations



Whitesales is able to advise on current requirements and regulations. The following pages summarise some of the key considerations that should be taken into account when specifying rooflights.

Approved Document L 2010: Conservation of fuel and power

Introduction

This Approved Document, which takes effect on 1 October 2010, deals with energy efficiency requirements in the Building Regulations (as amended) and is made up of four distinct publications which are summarised below. It should be noted that Approved Documents are guidance publications and there is some provision for trade-off with other building elements – any proposal should be checked with the relevant building control body. U-Values should be calculated in accordance with BRE 2006. The document also covers areas such as Materials and Workmanship including a requirement to demonstrate appropriate use of products with CE marking, British Standards and European Technical Approvals. Whitesales Em-Dome rooflights have undergone stringent and extensive testing and are certified to these standards.

Solar heat gain

Approved Documents L1A and L2A include requirements to limit solar gains through the summer period. The inside of the building can heat up during daylight hours due to the sun. This is termed as solar heat gain. To reduce this effect, solar control glass can be adopted to reflect heat and reduce glare from the sun's rays. This lessens the burden on air-conditioning systems thus reducing CO₂ emissions. In simple form, this may be body tinted glass in blue, green or bronze or more sophisticated, coated clear glass that allows maximum light transmission, but at the same time substantially reduces heat gain. For Em-Dome values, see page 9 of this brochure – Solar heat gain factor (g%).

Optimum rooflight provision

A building's design will affect the contribution rooflights can make. The optimum area of rooflights will therefore vary for each building. However, research has shown that a rooflight area of 15-20% will

contribute to an overall reduction in CO₂ emissions in most buildings. Rooflights are up to three times more effective at supplying daylight than vertical windows. Where artificial lighting is controlled by daylight sensors, installing rooflights can result in a significant reduction in the energy used for lighting. Energy consumed in lighting a building is often greater than that used to heat it. In addition, the SAP and SBEM software programs take account of the contribution made by passive solar gains through rooflights. Solar gains help to offset the increased heat loss of rooflights compared to the insulated main roof.

Air permeability

Air permeability is the physical property used to measure airtightness of the building fabric. It is defined as air leakage rate per hour per square metre of building envelope at the test reference pressure differential across the building envelope of 50 Pascal (50N/m²). The limiting air permeability is the worst allowable air permeability. The design air permeability is the target value set at design stage, and must always be no worse than the limiting value. The assessed air permeability is the value used in establishing the BER, and is based on a specific measurement of the building concerned.

ADL 1A: New dwellings



This document sets a minimum energy performance requirement called the 'Target CO₂ Emission Rate' (TER), and 'Dwelling CO₂ Emission Rate' (DER). The aim is to improve the overall building envelope rather than specific elements hence improvements in one area can be used to offset other areas of poorer performance. Section 4.20 covers 'Window, roof window, glazed rooflight, curtain walling and pedestrian door'. Specifically rooflights must conform to a U-value of no more than 2.00W/m²K and the calculation is based on the value of the complete rooflight unit rather than the values of any one component part.

ADL 1B: Existing dwellings



Section 4.19 covers 'Window, roof window or rooflight'. The document states that where windows, roof windows or rooflights are to be provided, the reasonable provision – in normal cases – would be the installation of draught-proofed units whose performance is no worse than a U-value of 1.6W/m²K or complying with the Window Energy Rating System, B and C.

ADL 2A: New buildings other than dwellings



This document sets a minimum energy performance requirement called the 'Target CO₂ Emission Rate' (TER), and 'Building CO₂ Emission Rate' (BER). The aim is to improve the overall building envelope rather than specific elements hence improvements in one area can be used to offset other areas of poorer performance. Section 4.30 covers 'Window, roof window, glazed rooflight, curtain walling and pedestrian door'. Specifically rooflights must conform to a U-value of no more than 2.2W/m²K. The calculation is based on the developed area of the rooflights rather than the roof aperture and is the value of the complete rooflight unit rather than the values of any one component part. Also included are 'Roof ventilators (inc. smoke vents)' which must conform to a U-value of no more than 3.5W/m²K.

ADL 2B: Existing buildings other than dwellings



Section 4.23 covers 'Window, roof window and glazed rooflight' and 'Plastic rooflight'. Specifically plastic rooflights must conform to a U-value of no more than 1.8W/m²k. Also included are 'Roof ventilators (inc. smoke vents)' which must conform to a U-value of no more than 3.5W/m²K.

Approved Document B 2006: Fire Safety



Approved Document B places certain limitations on the use of rooflights, which are dependent on glazing material and site circumstances, such as building size, use of area below rooflights, rooflight size and proportion of total roof area, distance from boundary etc. The relevant information is set out in Volume 1:

Sections 3 and 10; Volume 2: Sections 6, 12 and 13 of Approved Document B, 2006 Edition. Where applicable, the responsibility for determining that any building component complies with the relevant Regulations rests solely with the customer or specifier.

Approved Document E 2003 (amended): Resistance to the passage of sound



This document requires that buildings are designed and constructed to provide resistance to sound and reverberation. The aim is to limit noise disturbance by including sufficient acoustic properties and insulation in areas such as internal and external walls, floors and other elements. Rooflights should perform in accordance with these requirements and the decibel reduction value can be used in calculations for this purpose. For Em-Dome acoustic values see page 9 of this brochure and for Em-Glaze Modular see page 24. Further information is available in Building Bulletin 93 – Acoustic Design for Schools.

Approved Document F: Means of ventilation



This document places the responsibility on the designer to comply with ventilation requirements to new and existing buildings. It states ventilation types including extract, whole building and purge and gives minimum ventilation requirements.

Rooflights are often a useful means of complying with the requirements especially where no other external aperture is available. See pages 16-18 of this brochure for Em-Dome ventilation options. Further information is available in Building Bulletin 101 – Ventilation of School Buildings.

BS 6229

BS 6229: 1982, Code of Practice for flat roofs with continuously supported coverings, requires rooflights to incorporate upstands to raise them at least 150mm above the uppermost roof surface to which the roof covering is bonded or dressed. The designer should ensure that the builder's curb is at least 150mm high.

BRE BR443

Various standards deal with the calculation of U-values of building elements. The conventions provide guidance on the use of the standards, indicating the methods of calculation that are appropriate for different constructional types, providing additional

“
Rooflights are up to
three times
more effective
at supplying daylight
than vertical windows.
”

information about using the methods and providing data relevant to typical UK constructions. The U-value conventions were originally published by the BRE in 2002 and the 2006 edition is an update which provides additional information and reflects changes in the underlying British Standards. The U-Value calculation methods are also referred to in Approved Documents L1A, L1B, L2A and L2B.

Condensation

Condensation occurs where warm moist air meets cold surfaces. As warm air rises, the risk of condensation forming at rooflight level is relatively greater than at lower level. The risk can be minimised by specifying triple skin Em-Domes and Em-Curb insulated upstands. The provision of ventilation may also assist (see options on pages 16-18). However, because temperature and humidity levels are clearly beyond our control, no guarantee can be given against the formation of condensation.

Condensation between the skins can also occur when the room below has high humidity levels, for example during construction from new plaster or paintwork. Polycarbonate is hygroscopic and allows water molecules to filter through – the water pressure forces its way through the lower skin and condenses inside the cavity. However, once the humidity level in the room is restored to normal this condensation dissipates through the breathable seals.

Limitations on use

Whitesales modular rooflights are designed for use in normal circumstances on flat roofs up to 15° pitch (on flat roofs Em-Tube can be used up to 15° and on pitched roofs above 15°). For applications in excess of 15° or in unusual circumstances (e.g. extreme temperature or climatic conditions) please refer to Whitesales. Please note that all information supplied is based on our best knowledge and general experience. Because of factors outside our control which can affect installation and use of products, no warranty is given or implied in respect of information provided. A policy of continuous product improvement applies and Whitesales therefore reserve the right to alter specifications without prior notice.



Health & Safety



Construction (Design & Management) Regulations 2007

According to the Health and Safety Executive, almost 20% of deaths in the construction industry are caused by falls from or through roofs. The majority of these falls are through fragile materials such as asbestos cement roofing or old/fragile rooflights.

The Construction (Design and Management) Regulations 2007 places a duty on designers and specifiers to give proper consideration to eliminating or reducing risks at the design stage. Health and Safety Executive (HSE) Health and Safety in Roof Work draws attention to the responsibilities of those specifying rooflights.

(HSE) Health and Safety in Roof Work states that where rooflights are required, designers should consider:

- ◆ Specifying rooflights that are Non-Fragile.
- ◆ Fitting rooflights designed to project above the plane of the roof and which cannot be walked on (these reduce the risk but they should be capable of withstanding a person falling onto them).
- ◆ Protecting rooflight, e.g. by means of mesh or grids fitted below or above the rooflight
- ◆ Specifying rooflights with a design life that matches that of the roof, taking account of the likely deterioration due to ultraviolet exposure, environmental pollution and internal and external building environment.

For specifiers the key message is to eliminate 'fragile' materials from roof design. For contractors, provide effective fall arrest equipment or safety netting.

Non-fragile rooflights

Whitesales Em-Dome rooflights are out-of-plane rooflights, and provided they are specified with polycarbonate glazing, can be deemed to be 'non-fragile'.

- ◆ Polycarbonate Em-Domes have been independently tested according to EN 1873 2005 [E] to an energy of 1200J and to ACR[M] 001: 2005 and can be classified as Class B 'Non-Fragile'.
- ◆ Whitesales offers a 10 year warranty against discolouration of Em-Domes glazing material and, in the case of polycarbonate, loss of impact strength underwritten by the sheet material supplier.
- ◆ Whitesales polycarbonate Em-Domes have been awarded BBA Certification or are manufactured to ISO 9001.
- ◆ Whitesales offers a post-forming warranty backed by the sheet manufacturer.

Man-safe

Man-safe is a term often used within the construction industry to mean that the product can withstand foot traffic. However man-safe has no recognised definition and 'non-fragile' does not qualify a product to be used as a thoroughfare.

Whilst glazing and other accessories may be designed to safely resist the impact of a human body falling against it, the wilful act of walking on any kind of roof glazing must be forbidden at all times.

The act of walking upon a glazed structure can cause microscopic damage that, in time, may have a detrimental effect upon the impact performance of the system.

Walking upon glazing may encourage a practice that could lead to general disregard for the rating of said glazing, with catastrophic consequences.

Safety data sheets are available on request.

Sitework

Handling and storage

While all Whitesales modular rooflights and associated products are suitably packaged to avoid damage care should be exercised when handling. For moving larger items, two or more people may be needed. All products should be stored on edge in flat dry conditions.

Installation

All Em-Dome and Em-Glaze rooflights are supplied ready assembled and pre-drilled complete with security screwbolts and factory applied sealing tape where applicable and are delivered to site in protective packaging. Full instructions and fixings are included with all products, and should be carefully studied prior to installation.

Fixing upstand curbs

For fixing curbs to the roof structure, drill holes in the bottom flange, 100mm from each corner and at maximum 300mm centres and screw to roof structure. Typical installation details are shown below. The PVC-u Em-Curb is suitable for use with most flat roof systems including single ply, felt, hot-melt, asphalt, liquid and lead.

Where asphalt is specified, Whitesales recommend the use of PVC-u upstands with pre-fixed sheathing felt and expanded metal lathe. This must be specified if required.

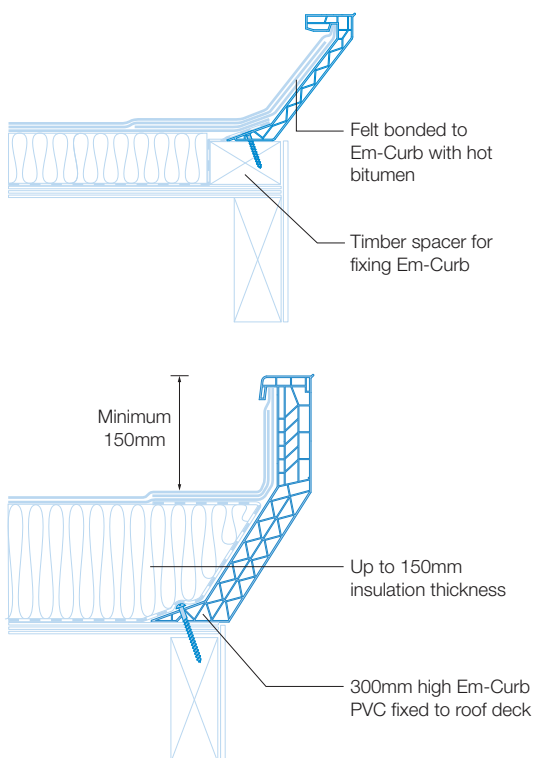

Fixing Em-Domes to Em-Curbs

The Em-Dome should be accurately positioned on the Em-Curb and the screwbolt fixing positions marked on the Em-Curbs. The fixing holes are drilled in the Em-Curb and the Em-Dome is simply placed in position and fixed using the screwbolt fixings supplied.

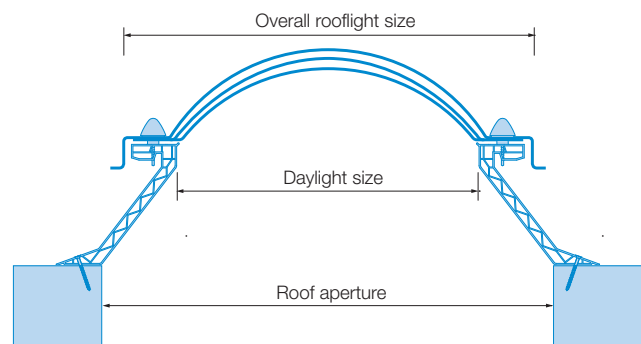

Fixing Em-Domes to builder's curbs

The Em-Dome overall rooflight size should be 60mm bigger than the outside dimensions of the upstand curb. Holes should be pre-drilled in the upstand curb to accept the tamper-proof screws provided for use with the screwbolt fixings. The fixing positions can be located by accurately placing the dome over the upstand curb, with the screwbolt caps removed, and marking the position of the fixings.

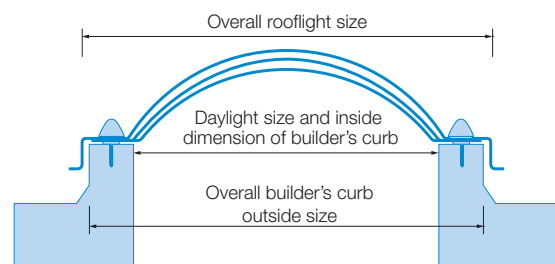

Em-Glaze installation

Refer to page 28.

Em-Tube installation

Refer to page 35.



Operation and maintenance



Whitesales rooflights and accessories can generally be regarded as 'maintenance free'. However, the following guidelines should be followed to optimize their usefulness.

Any maintenance of rooflights must of course be carried out strictly in accordance with the relevant 'Health and Safety' regulations.

Checks should be carried out on all products annually.

Project specific data is available on request.

Em-Dome and Em-Glaze

Operation: Em-Domes are fixed at installation stage to the relevant upstand, and are a means of allowing natural light into the area below.

Polycarbonate rooflights are 'Non-fragile', but should not be trafficked.

Maintenance: Wash only with warm soapy water. DO NOT USE strong detergents or abrasives.

Em-Curb

Operation: Normally manufactured in extruded PVCu, or GRP. Em-Curbs provide a proprietary upstand detail for Em-Domes.

Maintenance: Maintenance free.

GRP Em-Curbs may be decorated internally if required.

Em-Tube

Operation: Em-Tubes are fixed at installation stage to the relevant upstand, and are a means of allowing natural light into the area below. They are 'Non-fragile', but should not be trafficked.

Maintenance: Wash only with warm soapy water. DO NOT USE strong detergents or abrasives.

Passive ventilation

Operation: Normally by means of 'Trickle', 'Louvre' or 'Rotating' vents, to provide background ventilation. Trickle vents are adjusted by hand. Louvre and Rotating vents are adjusted by a proprietary operating rod – available in 1.5, 2 or 3m lengths. Louvre vents require a sharp upwards push to fully close.

Maintenance: Maintenance free.

Opening ventilation

Operation: Operated manually by spindle and proprietary winding rod, or electrically by means of 24V DC or 240V AC electric box motors. Manual operation opens to 300mm. Electric motors must be installed by a qualified electrician.

Maintenance: Test annually by an Approved Electrical Installations Testing Company. Physically check fixing brackets to ensure fixings are secure.

Access units

Operation: For means of access onto roof area. Only to be used by authorised personnel. Unit is opened by opening the locking cockspur handle and pushing the unit into the open position. If the unit has frictional struts, they should be adjusted to ensure unit is safely held in the open position. DO NOT use as a means of ventilation. DO NOT USE in windy conditions. ONLY USE in accordance with relevant Health and Safety Regulations.

Maintenance: Check brackets, struts, locking handle, etc., to ensure operation is correct and fixings are secure.

Extract fans

Operation: These are factory fitted to the relevant rooflight component and connected to an unswitched Fused-Spur.

A switched electrical supply should be connected by a qualified electrician.

Maintenance: Test annually by an Approved Electrical Installations Testing Company.



Project type Refurbishment

Products Em-Dome

Glazing Triple glazed polycarbonate clear 'HeatReflect' finish

Upstand Em-Curb PVC-u 300/s

Ventilation Controllable rotating vents



Support services



Technical services

Advice and technical assistance on the application and specification of all rooflights and accessories is readily available from Whitesales.

Full technical advice is available, including technical specification writing, site surveys, condition reports and budget costings or fully detailed quotations.

A comprehensive library of product data sheets and CAD drawings is available along with NBS specifications.

For projects where we have undertaken a rooflight site survey we offer a CAD roof plan drawing service.

The Whitesales Customer Service Team works to respond immediately to customer request.

For more information, please contact us on:

Tel **02392 359 831**

E-mail
sales@theskylightcompany.co.uk

Nationwide coverage and next day delivery

Whitesales offers next day delivery on their own transport or overnight carrier service nationwide, including deliveries to site, to contractors and merchants.

With depots strategically located in England and Scotland, the service driven team is readily available, from your initial enquiry through to after sales support.

Project and larger consignments are delivered on Whitesales' own transport and delivery periods are determined on a per order basis.

Guarantees

All Em-Dome rooflights, when installed on Em-Curbs, Em-Collars or T-Collars and in accordance with manufacturer's instructions, are guaranteed against the effects of defective design, materials or construction for a period of ten years from date of supply by Whitesales. Furthermore, the glazing element of all Em-Domes is warranted against discolouration for ten years subject to certain conditions. A 20 year 'special projects' guarantee is also available. Further details available on request.

Em-Dome rooflights have an expected life of at least 25 years which would normally exceed the life of the roof waterproofing materials.

All other products (e.g. T-Collars, Em-Curbs, ventilation systems, electrical components and other accessories) are guaranteed for 12 months from date of supply by Whitesales.

Whitesales holds Professional Indemnity Insurance, covering our designs and recommendations. Full details available on request.

Environment



Our responsibility

The environment and the effect we have upon it is one of the key issues facing the construction industry.

There is a growing demand for construction solutions which minimise the consumption and use of natural resources. Whitesales recognises the impact that we can have on the environment and is managing activities to maximise our contribution towards the protection of the environment and preservation of natural resources. This includes constant reviews of our manufacturing operations and distribution chain.

Sustainability

Sustainable developments ensure a better quality of life for everyone, now and for future generations. To be environmentally sustainable a product must be manufactured and used in a way that minimises its impact on the environment.

Sustainability covers all aspects of a product's impact on the environment. This includes original source of raw materials, the manufacturing process, transportation, construction, life span of the product and eventual disposal and re-use of the material.

Environmental policy

In maintaining and developing our business, products and services, we will pay careful attention to the following measures:

- ◆ Comply immediately with all applicable laws and regulations concerning the environment.
- ◆ Develop manufacturing processes and operational procedures that minimise, as far as practically possible, pollution risks to the environment.
- ◆ Reduce waste generated by our activities and encourage energy conservation, recycling and re-use.
- ◆ Provide training and support to employees to enable them to maximise their contribution towards the protection of the environment.
- ◆ Encourage suppliers, contractors and customers to share in our aims to promote good environmental management.





Rooflights & more... |