



Contact us

If you are a small, medium or large scale food manufacturer seeking a high quality system to accurately fill jars, bottles, pots, tubs, ready meal trays, foils, cake tins, buckets, jerry cans, pouches or bags, then Riggs Autopack could have the right solution for you.

For more information on our range of equipment, please visit our website. Alternatively, to discuss your specific requirements or to book a no obligation machine trial don't hesitate to contact us.

Premier Mill, Brunswick Street
Nelson, Lancashire BB9 0HU, UK

T +44 (0) 1282 440 040
F +44 (0) 1282 440 041
E enquiries@riggsautopack.co.uk

www.riggsautopack.co.uk

[@riggsautopack](https://twitter.com/riggsautopack)



Series Six Our Model 1000 food grade transfer pumps provide damage free transfer of hot or cold liquid, semi-liquid, suspended solids, viscous and fragile products

Riggs Autopack is an award winning, British manufacturer of high quality volumetric depositors and filling machines, transfer pumps and bespoke conveyor filling lines.

We are a UK market leader with an excellent reputation and supply our equipment primarily to the food production industry.

www.riggsautopack.co.uk

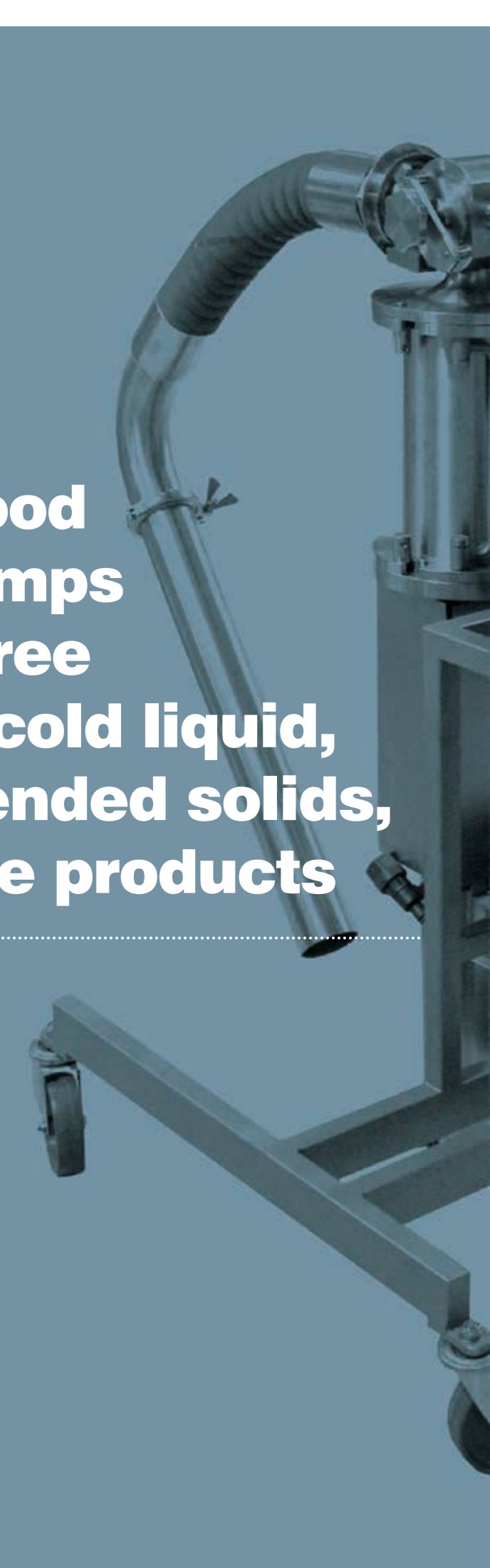
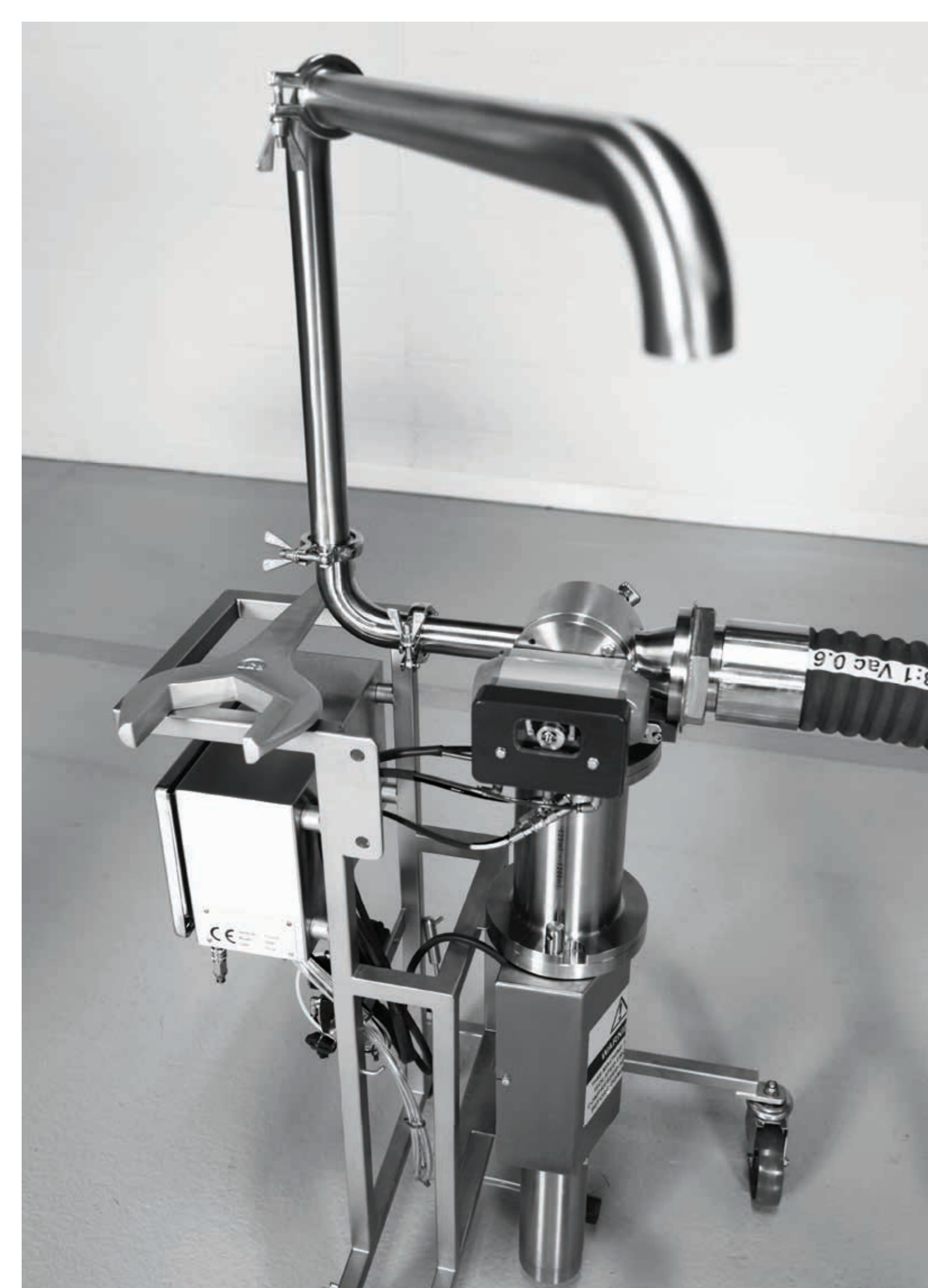

These hygienic food pumps provide continuous production and negate the need for manual loading of hoppers by using tubs or buckets



Simple and easy to use, they efficiently pump products direct from tote bins, pallets, cooking kettles or mixing vessels via a drop tube or direct connection to an outlet, and transfer into low or high level hoppers and holding tanks.

Features include

- + Piston pump technology
- + High quality, robust construction
- + Suitable for small, medium and large scale batch production
- + Designed for hot, cold or ambient liquid, semi-liquid and suspended solid products
- + Low or high level transfer
- + Damage free product handling
- + Mobile frame with lockable castors
- + Nitrite / viton / ptfе / ptfе encapsulated seals
- + 316 stainless steel used for all contact parts
- + 304 stainless steel used for non-contact parts
- + Built to stringent health & safety standards
- + Hygienic, quick to strip down, easy to clean
- + Easy to use, simple to maintain
- + Requires compressed air supply



Model 1000 / Series Six / Transfer Pumps

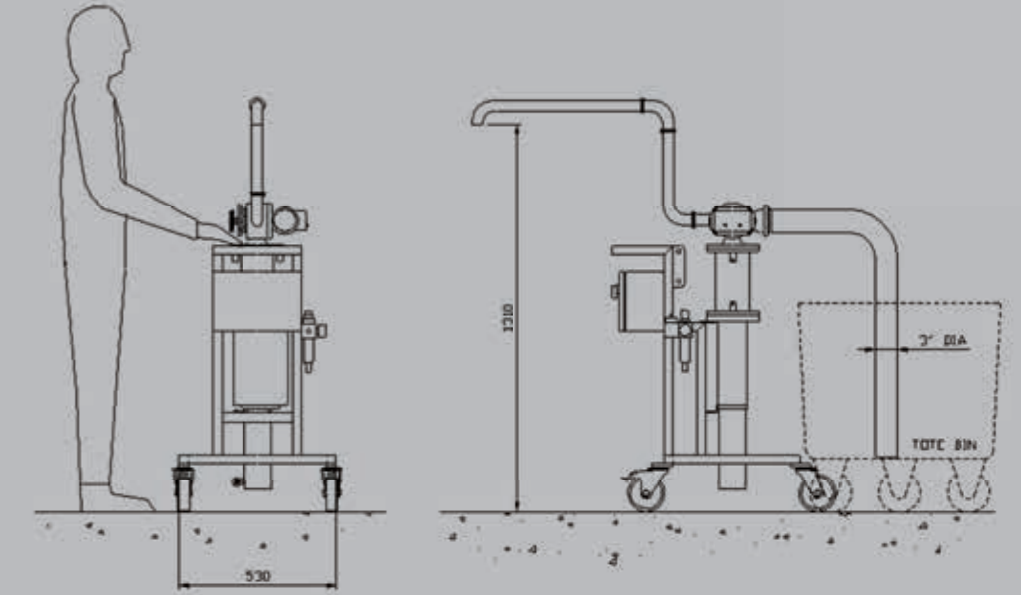

Suitable applications typically include

- + Jam, Preserves & Honey
- + Condiments & Sauces
- + Pate, Dips & Spreads
- + Coleslaw & Pasta Salads
- + Sandwich & Pie Fillings
- + Soup & Ready Meals
- + Cakes, Puddings & Desserts
- + Dairy Goods
- + Seafood Products
- + Non-Food Industry

Piston Pump Barrel Options

- + Standard 4.0 - nominal transfer rate up to 26 litres per minute
- + Maxi 5.125 - nominal bulk transfer rate up to 50 litres per minute
- + Maxi 6.5 - nominal bulk transfer rate up to 80 litres per minute

