



The ‘E’ difference

A significant enhancement to the Curtis AC family, The ‘E’ models utilize a powerful dual-microprocessor logic architecture to provide improved performance and surpass the requirements of the latest international functional safety standards.

DESCRIPTION

The Curtis model 1234E provides advanced control of AC induction motors performing on-vehicle traction drive or hydraulic pump duties, and offers the highest levels of functional safety.

APPLICATION

The Curtis Model 1234E is intended for use as the traction or hydraulic pump motor controller on a wide variety of material handling vehicles, warehouse trucks and other industrial vehicles.

Only Curtis AC can offer:

- **Curtis VCL™—Vehicle Control Language** is an easy to use programming language that allows vehicle developers to write powerful logic functions and create a ‘virtual system controller’. Curtis offers customers VCL development tools and training. Curtis also provides a VCL service where Curtis engineers will work with the OEM to create any custom VCL code required.
- **Indirect Field Orientation (IFO) vector control** algorithm generates the maximum possible torque and efficiency across the entire speed range. Advanced Curtis IFO vector control provides superb drive ‘feel’, improved speed regulation and increased gradeability.
- **Curtis Auto-Tune** function enables quick and easy characterization of the AC motor without having to remove it from the vehicle. Curtis AC controllers are fully compatible with any brand of AC motor.
- **Dual-Drive functionality** is standard, allowing correct control of applications featuring twin traction motors. This function ensures smooth and safe operation, minimal tire wear and correct load sharing between the traction motors at all times.
- **Configurable CANbus** connection allows communication with other CANbus enabled devices. Model 1234E is CANopen compatible and provides 20 VCL-configurable CAN ‘mailboxes’, 6 more than earlier Curtis AC controllers.
- **Integrated System Controller**—More than just a motor controller, it is also powerful system controller. It features a comprehensive allocation of multi-function I/O pins for use as analog inputs, digital inputs, contactor coil drivers and proportional valve drivers. In addition to this local I/O, this controller can use VCL to map and configure the remote I/O available on other CANbus devices, send messages to CAN displays and thus control and monitor the entire system.

FEATURES

Increased Performance, Improved functionality

- Higher performance form, fit and functional replacements for earlier Curtis Model 1234 AC controllers.
- CE marked as a programmable safety device under EN ISO 13849-1.
- Models available from 250–350A output at 24–80V system voltages.
- Enhanced 64MHz micro and additional FLASH memory doubles the available VCL code space and provides more than twice the VCL execution speed.
- Six additional VCL-configurable CAN ‘mailboxes’ significantly increases CAN master capabilities.
- Advanced Pulse Width Modulation techniques produce low motor harmonics, low torque ripple and minimized heating losses, resulting in high efficiency.

MODEL 1234E

FEATURES continued

Unmatched Flexibility

- Programmable for either traction or pump applications.
- Field upgradeable software.
- Integrated Battery state-of-charge algorithm and hour meters.
- Fully-featured generic software and VCL for typical Warehouse Truck applications is included.
- Comprehensive programming options and VCL allow other applications to be easily supported.
- Curtis hand-held or PC Windows programming tools provide easy programming and powerful system diagnostic tools.
- Integrated status LED provides instant diagnostic indication.

Robust Safety and Reliability

- Dual Microprocessor architecture cross-checks critical circuits, logic, and software functions to ensure the highest possible functional safety performance level is achieved.
- Insulated metal substrate power-base provides superior heat transfer for increased reliability.
- Fail-Safe power component design.

- Reverse polarity protection on battery connections.
- Short circuit protection on all output drivers.
- Thermal cutback, warning, and automatic shutdown provide protection to motor and controller.
- Rugged sealed housing and connectors meet IP65 environmental sealing standards for use in harsh environments.

Meets or complies with relevant US and International Regulations

EMC: Designed to the requirements of EN12895.

Safety: Designed to the requirements of:

EN1175-1:1998+A1:2010

EN (ISO) 13849-1

IP65 Rated per IEC 60529.

UL recognized per UL583.

Regulatory compliance of the complete vehicle system with the controller installed is the responsibility of the vehicle OEM.

FUNCTIONAL SAFETY DATA

Safety Function	PL	Designated Architecture	MTTFd	DC
Uncommanded Powered Movement	d	Category 2	≥40 yrs	≥90%
Motor Braking Torque	c	Category 2	≥16 yrs	≥90%

MODEL CHART

Model	Nominal Battery Voltage (V)	2 Min RMS Current Rating (A)	S2-60 Min RMS Current Rating (A)
1234E-23XX	24	350	175
1234E-52XX	36-48	275	140
1234E-53XX	36-48	350	175
1234E-62XX	48-80	250	110

SYSTEM ACCESSORIES



The Curtis Model 1222 is an AC induction motor controller for 'steer by wire' electric power steering systems and is the ideal partner for the 1234E on vehicles such as reach trucks, order pickers, stackers and other similar industrial vehicles.



The Curtis model 1352 CANbus I/O expansion module features 9 I/O pins, including 6 proportional valve drivers. This module can be used to further expand the I/O capability of Curtis AC motor controllers using VCL.



The Curtis Model 1313 Handheld Programmer is ideal for setting parameters and performing diagnostic functions.

Contact Curtis to obtain the VCL Vehicle Control Language compiler and development tools.

MODEL 1234E

CONNECTOR WIRING

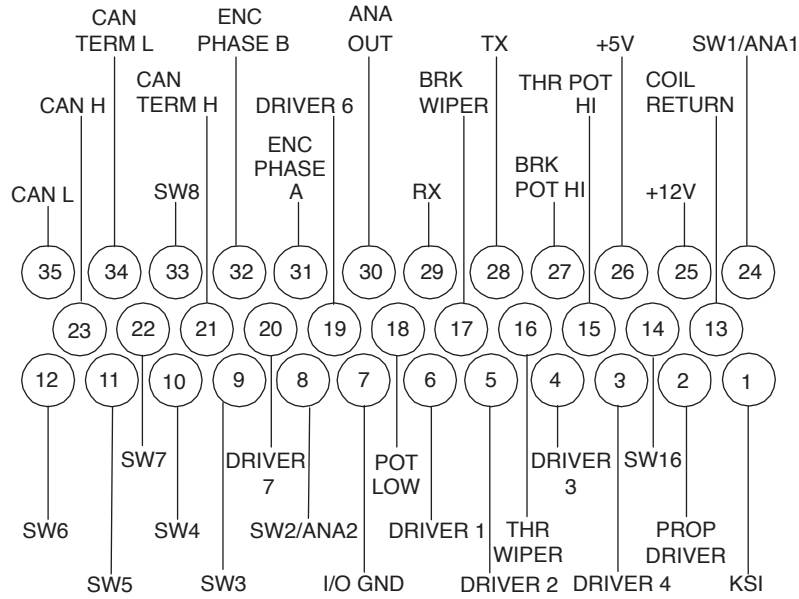

DIMENSIONS mm (typical)

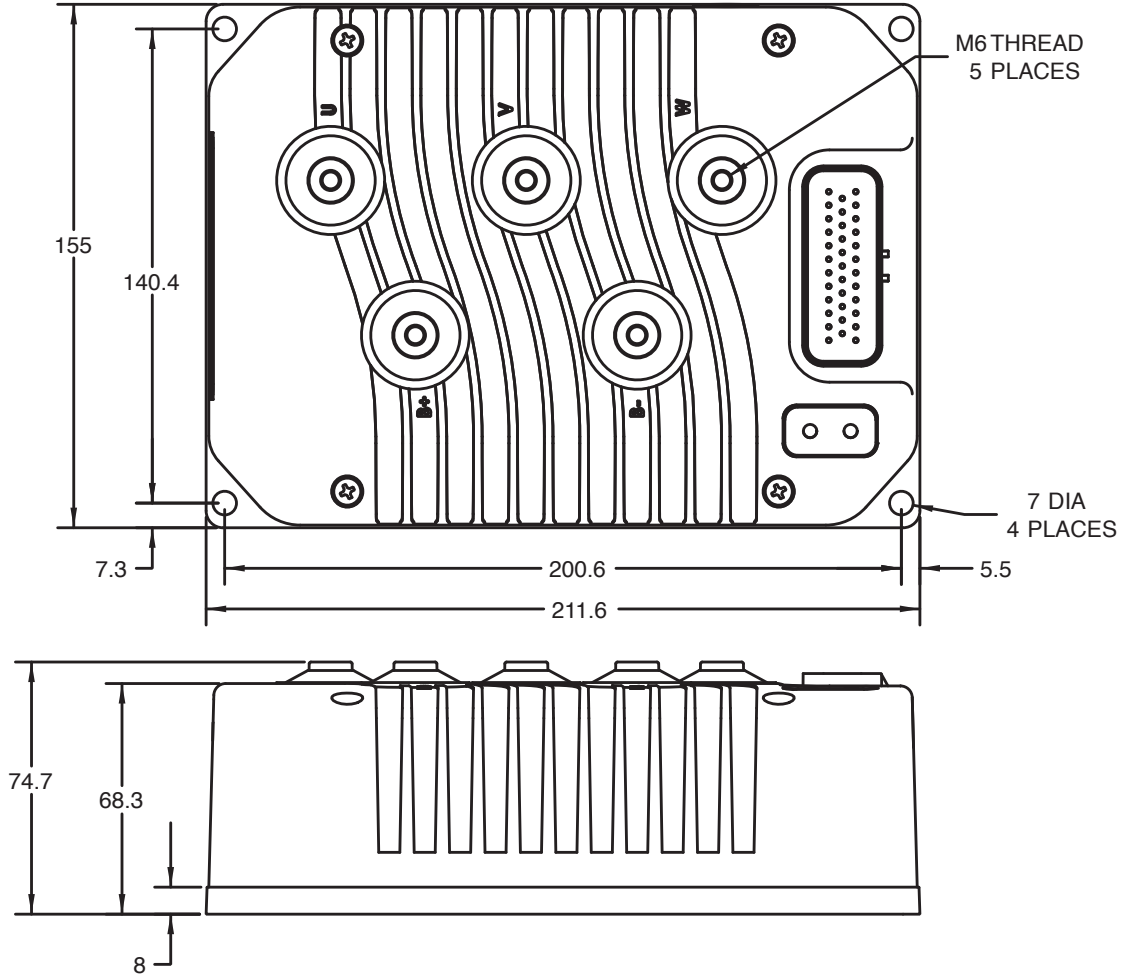

MODEL 1234E

TYPICAL WIRING

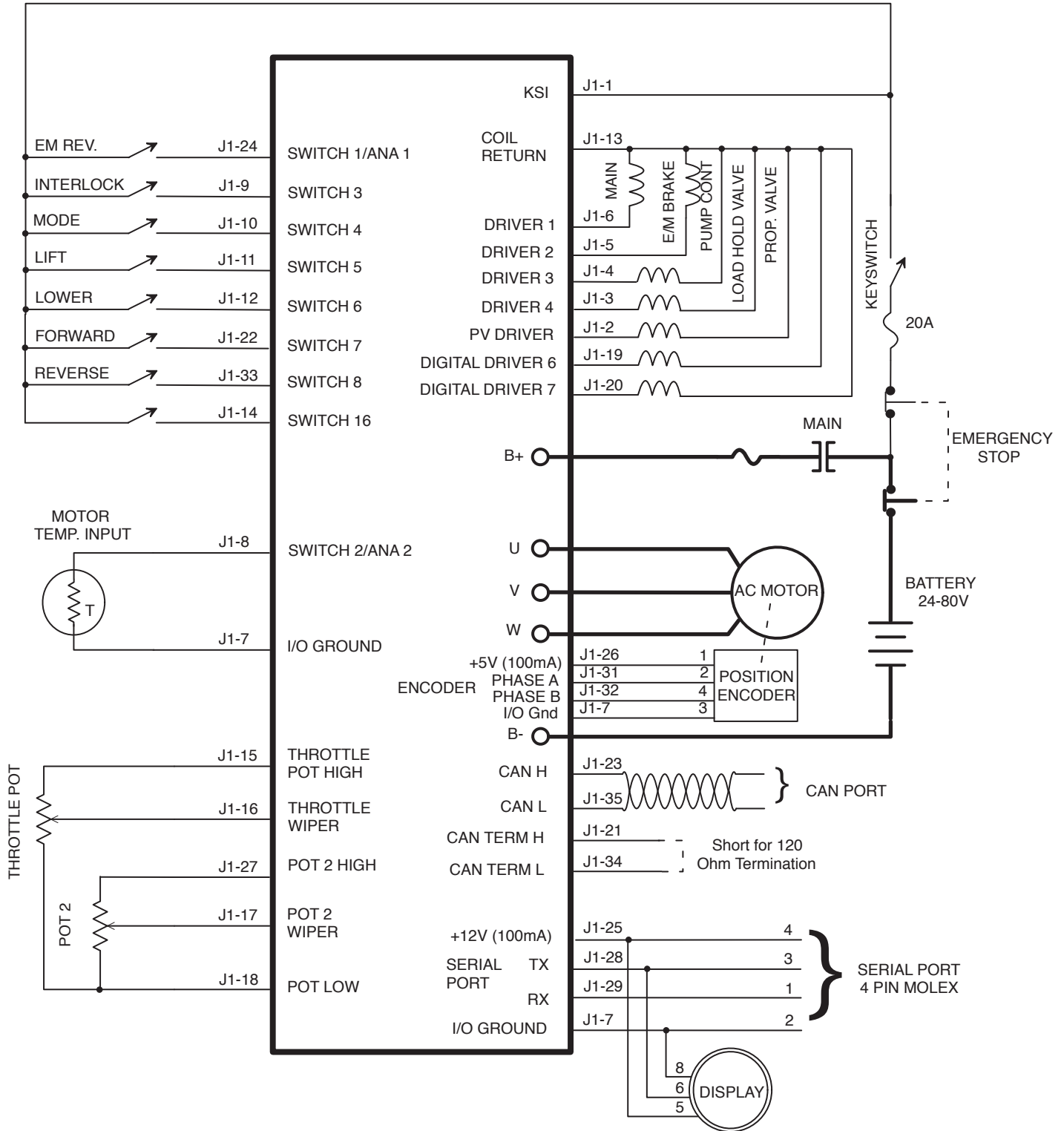

WARRANTY Two year limited warranty from time of delivery.

The Curtis Difference
You feel it when you drive it