

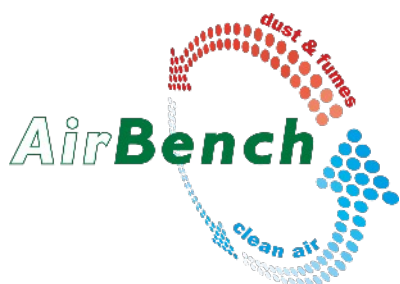

OMF500



+44 (0) 1206 791191

sales@airbench.com

www.airbench.com

14 Grange Farm Road, Colchester CO2 8JW





Filter Gauges

Large face 0-1000Pa gauges complete with 'filter full' indicator

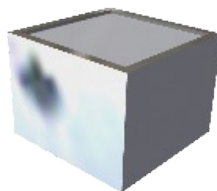

Isolator and indicators

Rotary isolator and on/off/error indicators.

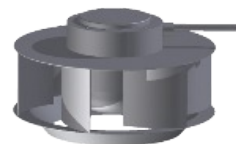

Fan

500w high power backward curve centrifugal fan.

HEPA cartridge

Designed to remove submicronic particulate with an efficiency of 99.9%

Pre-Filter

High efficiency filter media construction for oil/coolant mist with 'non clogging' properties and long filter life (washable)



Filter Clamp Mechanism

Spring loaded roller bearing filter clamp mechanism with tubular handles for securing filters

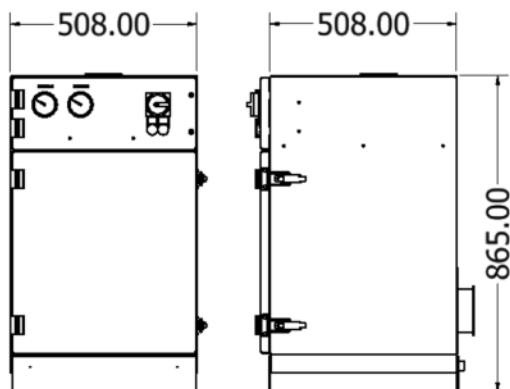

Fan Type
Fan Power
Airflow
Dimensions
Inlet
Colour

Backward Curved Centrifugal
250w
500m³/h Nominal
508x508x865 mm
150mm Clipped Ducting
RAL7035 as standard

+44 (0) 1206 791191

sales@airbench.com

www.airbench.com

14 Grange Farm Road, Colchester CO2 8JW

