

Bulk bag unloading: Control and safety basics

Catherine Podevyn, Spiroflow Ltd.

This technical paper is reproduced from Powder Bulk Engineering International

Bulk bags, also called flexible intermediate bulk containers (FIBCs) have evolved from handling low cost, high tonnage materials to dosing small quantities of specialty ingredients. Key to this development was controllable, safe unloading equipment. This article introduces you to bulk bag unloading equipment and describes the special features that adapt the equipment for different applications.

The use of bulk bags has grown dramatically over the last 20 years. Worldwide, more than 100 million bulk bags are produced each year. Much of the growth in bulk bag use can be attributed to legislation aimed at reducing the strain on workers' backs and preventing other common injuries in the workplace. That's why many products that had been supplied in 25-kilogram bags are now supplied in bulk bags.

Good economics also favor the use of bulk bags. Only 15 years ago bulk bags were used for large tonnage, low value products such as sand and cement. Today, bulk bags transport and dispense high-value products such as organic food ingredients, specialty chemicals, and pharmaceuticals. Nearly every processor can justify the economics of switching from 25 kilogram bags to bulk bags. Bulk bags also serve as a means of intermediate, in-plant storage.

Of course, many products are difficult to handle or generate dust, so equipment manufacturers had to engineer machines to cope with these problems. The manufacturers also developed ways to interface bulk bag dischargers with other handling and processing equipment. Today you will find that bulk bag dischargers are nearly universally applicable because of their flexibility in operation. In fact, today's bulk bag dischargers can conform to the technical standards of any industry.

For instance, in the food and pharmaceutical industries, the dischargers must meet strict standards for hygiene. They must also meter the ingredients precisely. Some pharmaceutical ingredients are worth US\$20,000 per metric ton. Obviously, the equipment that discharges this ingredient must eliminate spillage, feed accurately, and stop dust.

As you can see by these questions, the decision to accept bulk bags is not a simple one, so be careful not to underestimate the task. True, you can buy a basic discharging frame that just suspends the bulk bag over a receiving hopper, but these simple frames, often made in-house or by a local metal fabricator, are substantially inferior. Most do not include the safety and handling features that professionally built equipment includes.

The main application for these simple frames is handling basic materials such as sugar or salt, which do not present

Choosing the right equipment

If you wish to add a bulk bag discharger to your operation, begin by answering these questions:

1. Must the discharger accept different bag sizes?
2. Must it handle poor flowing products?
3. How will you load the discharger? By forklift truck or by integral hoist?
4. Must the machine enable you to control product flow after you open the bag?
5. How sure are you that the discharger will empty the bulk bag completely?
6. Must you discharge your product by weight or by volume?
7. Do you need a device to restrain or remove bulk bag liners?
8. Do you need an integral conveyor to transfer the bag contents to another location?
9. Is there a height restriction where you plan to install the discharger?
10. Must the discharger accept 25-kilogram bags in case the supply of bulk bags is interrupted?
11. Must your application meet the hygienic requirements of the USDA or FDA?
12. What dust control features must the machine include?
 - A. When untying the bag spout?
 - B. While the product is being discharged?
 - C. When the liner is removed?
 - D. When the bag is removed and folded for disposal?
13. Is the product or environment hazardous? Do you require electrostatic containment or monitoring?

many flow or dust problems. Yet the frames still pose serious safety risks because the bulk bag is not properly supported underneath. Furthermore, the simple frames do not empty the bag completely and they allow dust to escape. Workers will waste valuable time cleaning up the mess that these frames create. The result: You will not receive all the benefits that bulk bags can provide.

The following sections of this article will help you identify properly designed equipment that discharges difficult products in a safe, clean, reliable manner.

How bulk bag dischargers operate

Before we discuss how to control and safely operate bulk bag dischargers, here is a brief description of the discharging procedure. More information is available from the European Flexible Intermediate Bulk Container Association (EFIBCA)¹ or the US Flexible Intermediate Bulk Container Association (FIBCA).² Some operations, such as massaging the bag instead of using vibration, vary from manufacturer to manufacturer. Likewise, manufacturers use different methods to close the spout of the bulk bag before it is retied. These are details to address later when you know your exact needs. Figure 1 shows a standard bulk bag discharger. Figure 2 shows bag massagers.

1. A worker hooks the bulk bag's four loops over the lifting, or rigging frame. If applicable, the liner is clamped at the top of the frame.
2. A forklift truck or hoist lifts the bulk bag onto the discharger. The bag rests on a support dish that, combined with the weight of the bag, forms a dust-suppression seal that encases the bag spout.
3. An access door (with safety interlocks) lets the worker reach the bag spout to untie the string that holds it closed. Pinch bars, or another type of restraint, hold the spout closed until the worker shuts the door.
4. With spout open, the bag discharges its contents. As the weight of the bag decreases, spring-loaded support arms gradually rise, lifting the rigging frame and tightening the bag. The tension on the bag prevents it from folding and trapping product. It also prevents the spout or liner from sagging and becoming caught in the discharge conveyor below.

5. For faster discharging, the support arms can operate pneumatically in tandem with devices that promote flow. Massaging devices pushing against the sides and bottom of the bulk bag are particularly effective in loosening compacted powders and restoring free flow.

Batching from bulk bags

Customers who need to discharge bulk bags automatically can use a loss-in-weight discharger. This type of discharger includes a bag support dish mounted on load cells. The load cells are linked to a batch controller, giving you the ability to bulk-feed and dribble-feed. A loss-in-weight discharger can pause and resume feeding. It can also retain in electronic memory the amount of product it dispensed after a bag is empty. When you load the next bag, it recalls the weight needed and resumes dispensing product until it reaches the target amount.

You can also use a single machine to batch several ingredients. You just close the spout of the bag, tie it off, and remove the bag. Then you replace it with another bulk bag and begin unloading. There several methods of closing the spout so you can tie it off. One uses round pinch bars that form a circular yoke around the spout.³ Other methods use flat pinch bars, cables, or iris valves. Whatever method you choose, make sure it stops flow completely and enables you to re-tie the spout easily. If you would prefer not to remove the bulk bag to add other ingredients, select a discharger that includes a special dump door. The door enables you to discharge the contents of 25-kilogram bags.

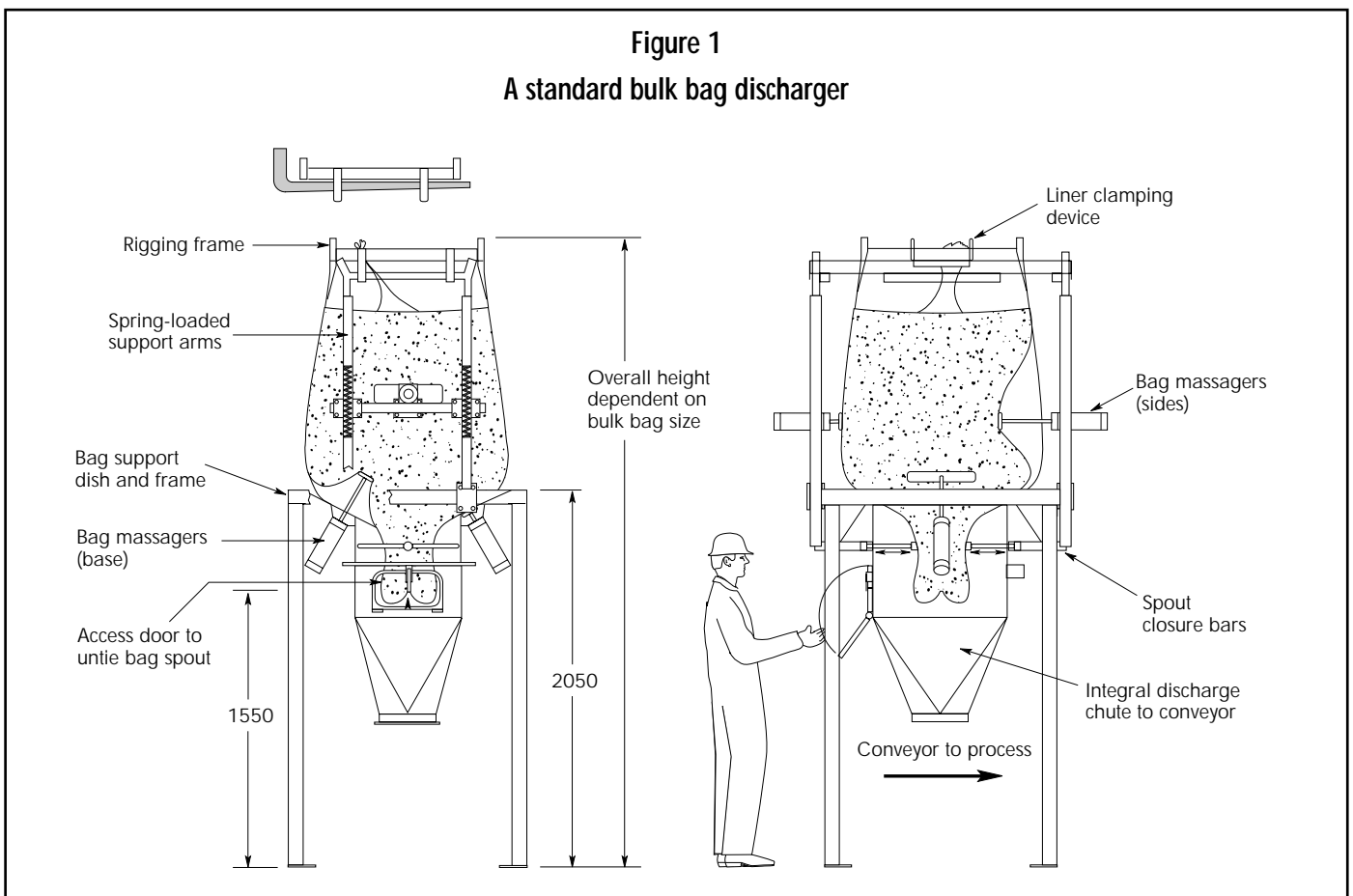

Versatility

In cases where a low ceiling prevents a normal forklift truck from loading the bulk bags onto the discharger, ask the equipment manufacturer for a low-profile machine. It will enable you to use a “low-lift” forklift truck. If you don’t use forklift trucks, select a discharger with an integral hoist. The discharger can also include an integral sieve and an integral conveyor to carry the ingredients to weigh hoppers, mixers, or other processes. See Figure 3.

For applications where the process receives ingredients from different sources and in different containers, select a bulk bag discharger that can unload rigid bins (as well as 25-kilo-gram bags as discussed above). Rigid bins come in all shapes and sizes, so the rigging frame will need a custom design. You might also investigate replacing the rigid containers with newly developed bulk bags that meet the United Nations’ Chapter 16 requirements for safety. A mobile discharging frame is also available, enabling you to discharge ingredients at different locations.

Figure 2

Bag massagers at the base and sides of the bulk bag

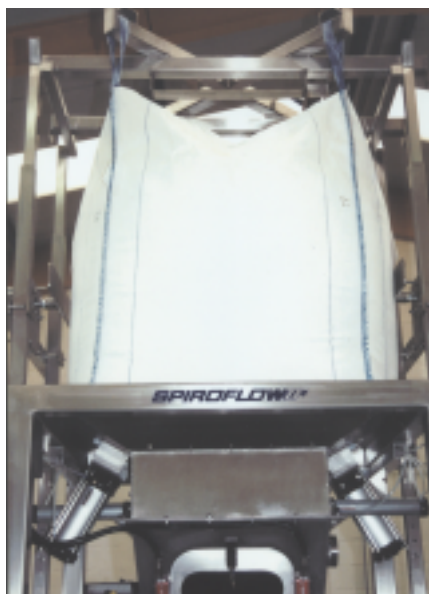

Sanitary operation

Dischargers are at work in all industries, especially the food industry, where the machine must meet the requirements of the United States Department of Agriculture (USDA), the US Food and Drug Administration (FDA), or similar agencies. In these types of units, contaminants on the base of the bag are trapped in an outer chamber, while clean product passes through a tube directly to an integral transfer conveyor. Quick-release clamps and self-draining surfaces ease routine cleaning.

In clean rooms or hazardous environments, the discharger will require a glove box that gives you access to the bag spout. By placing your hands into the gloves, you can manipulate the bag spout without contacting the contents of the bag. The glove box also prevents the contents from entering the work environment. These dischargers release as little as 0.025 micrograms of product per cubic meter of air.

Figure 3

Bulk bag dischargers with integral hoists, sieves, and flexible screw conveyors



Integral transfer conveyors

The nature of some ingredients (such as foods) demands that they be handled without exposure to air. Flexible screw conveyors are well suited for this task because they are completely sanitary and sealed. All the metal contact parts are stainless steel and the plastic conveying tube is made from food-grade polymers. Ambient air and moisture cannot enter. The flexible screw conveyor can also handle materials with a range of particle sizes without segregation by size, particle size reduction, or thermal degradation. The conveyor's discharge is continuous and maintains a constant rate. Typically, the unit dispenses material to within 1 percent of the target amount. For special applications, the accuracy can reach 0.1 percent. Capacity is as high as 30 metric tons per hour.

Controlling static electricity

The action of filling and emptying bulk bags can generate static electricity that accumulates on the walls of the bag. If not checked, the electrostatic charge can generate a spark, which might trigger an explosion or fire under certain conditions. To prevent this, the bag should be electrically grounded via a conductive bulk bag and a circuit-monitoring device.

Handling liners and empty bags

It's your choice whether to remove the liners from empty bulk bags by hand or by a powered retraction device. Either way, the liner is removed and compressed into a plastic sock. When the sock is full, you tie off the end of it and the accumulated liners are ready for disposal or further compaction.

Empty bags are best handled on a folding table to reduce dust emissions. The folding table includes an integral exhaust hood, to which you clamp the bag spout. As you fold the bag from top to bottom, the dust-laden air is displaced out of the spout, into the exhaust hood, and on to a dust collector.

Conclusion

Understanding the safety and control requirements for your bulk bag discharging operation will help you to specify the correct machine for your application. Be careful of simple discharging frames built in-house or by local metal fabricators. You will pay more in cleaning and down-time than you would by specifying a quality machine from the start. It is up to you to decide which suppliers offer the best technology, compatibility, and quality.

PBE International

Catherine Podevyn is the marketing director at Spiroflow Ltd., Lincoln Way, Clitheroe, Lancashire, BB7 1QG, England. Tel.: +44 1200 422 525, fax +44 1200 429 165. Website: www.spiroflow.com. Podevyn, a graduate of the University of Manchester in Manchester, England, has more than 20 years experience in bulk bag handling, filling, and discharging. She is also a council member of the UK's Solids Handling and Processing Association (SHAPA).

Reference

1. European Flexible Intermediate Bulk Container Association (EFIBCA)
140 Camphill Road, Broughty Ferry, Dundee DD5 2NF, Scotland
Tel: 01382 480049 Fax: 01382 480130
2. Flexible Intermediate Bulk Container Association (FIBCA)
PO Box 2206, Macon, GA31203 USA. Tel +1 912 757 1006,
Fax +1 912 757 9444. Website: www.fibca.com.
3. Patented by Spiroflow, Clitheroe, UK.

Spiroflow Limited

Lincoln Way, Clitheroe, Lancashire BB& 1QG, UK

Tel: 01200 422525 Fax: 01200 429165

email: info@spiroflow.com

website: www.spiroflow.com

Spiroflow Systems, Inc

2806 Gray Fox Road, Monroe, NC 28110, USA

Tel: (704) 291 9595 Fax: (704) 291 9594

email: info@spiroflowsystems.com

website: www.spiroflowsystems.com