

PRECISION VALVES



Waverley brownall

THE COMPANY



Waverley brownall has progressed to become a leading supplier of pipeline components, valves and instrumentation products; providing solutions for the most demanding applications.

Our philosophy is dominated by quality. Each Waverley brownall product is designed using state-of-the-art CAD technology and is subjected to rigorous quality control procedures.

Waverley has built its reputation for quality instrumentation among the largest industrial companies. Our products are used on systems where corrosion resistance, high pressures, clean room environments and high temperatures are critical factors.

A range of over 2000 standard products, manufactured in the UK or sourced from approved suppliers are available ex-stock to assure you of immediate delivery whilst our engineers provide complete technical support and can assist in the design and development of custom-made solutions.

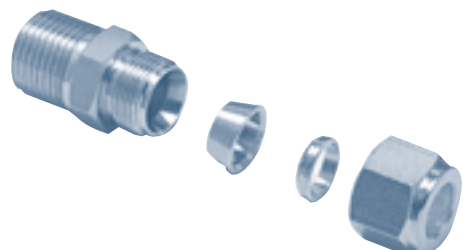
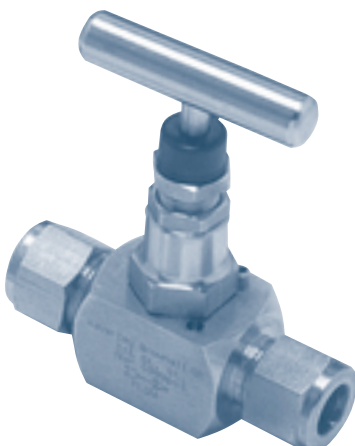
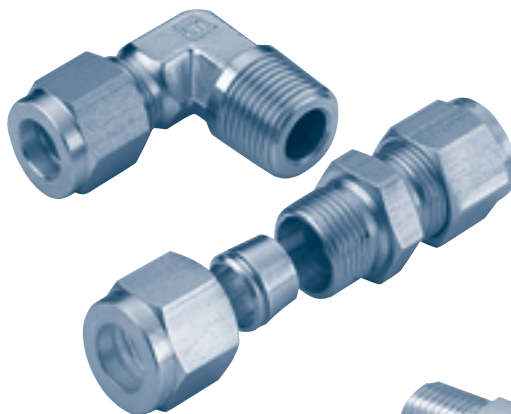
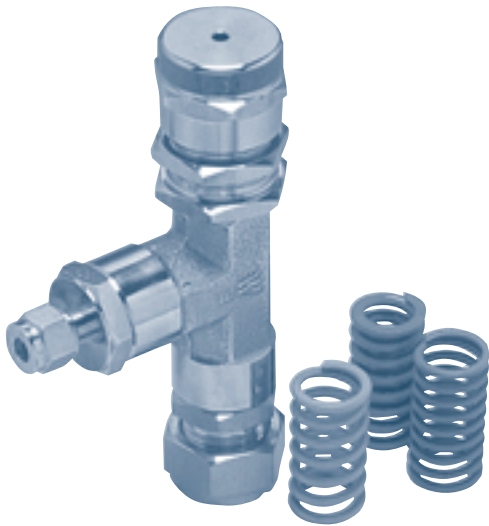

APPROVALS

Our dedication to quality has led to us being awarded and maintaining BS EN ISO 9001 since 1986.

We also hold certificates of product conformance and approvals which include:

- LLOYDS** type approval to BS part 4
- LLOYDS** general approval for classified installations
- TUV** type approval
- AF KONTROLL** design approval
- BRITISH GAS** approved supplier
- BRITISH PETROLEUM** approved supplier
- BRITISH NUCLEAR FUELS** approved supplier
- SHELL** approved supplier
- TEXACO** approved supplier
- CEGB** approval
- POWERGEN** approved supplier
- EUROPEAN GAS TURBINES** approved supplier
- AMERICAN BUREAU OF SHIPPING** type approval
- B.O.L.** approved supplier



UK Sales

Waverley brownall Ltd
46, The Vintners, Temple Farm Industrial Estate
Southend-on-Sea, Essex SS2 5RZ
Tel: +44 (0)1702 600014
Fax: +44 (0)1702 613600
email: sales@waverleybrownall.co.uk
www.waverleybrownall.co.uk

Waverley brownall Scotland
Tel: +44 (0)1224 877323

1000lb Class Ball Valves



FEMALE/FEMALE
PAGE 10



MALE/FEMALE
PAGE 10



STRAIGHT HOSETAIL
PAGE 11

3000lb/6000lb Class Ball Valves



FEMALE/FEMALE
PAGE 17



MALE/FEMALE
PAGE 17



COMPRESSION ENDS
PAGES 18 & 19



CAST VALVES
SINGLE PIECE, 2 PIECE
AND 3 PIECE
PAGE 24



3 WAY BALL VALVES
PAGE 28



AIR ACTUATED BALL VALVES
PAGE 10

Needle Valves



MALE/MALE, FEMALE/FEMALE and MALE/FEMALE
NPT, BSPT and BSPP ENDED NEEDLE VALVES
PAGE 37

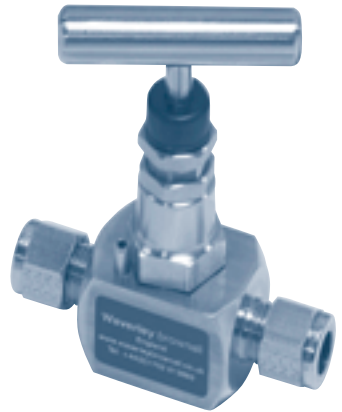

COMPRESSION ENDED
NEEDLE VALVES
PAGE 40

Manifold Valves



2 WAY
PAGE 44

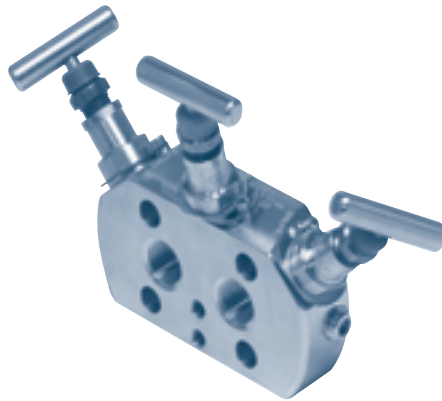

3 WAY
PAGE 45

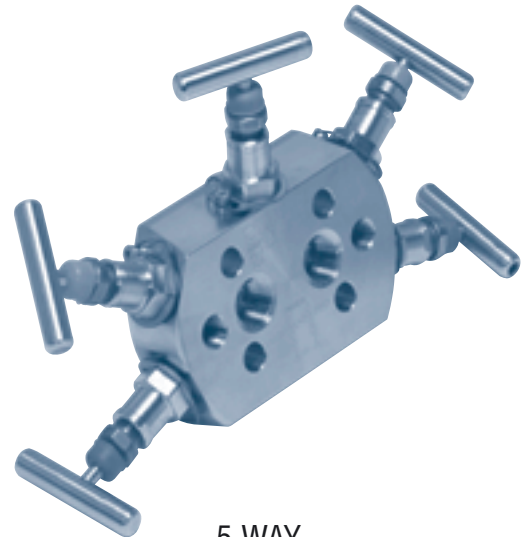

5 WAY
PAGE 45

Monoflange Valves, Distribution Manifolds and Flanges



MONOFLANGE VALVES
PAGE 48



AIR DISTRIBUTION
PAGE 50



O.D. FLANGES
PAGE 51

CV Series Check Valve



FEMALE/FEMALE
PAGE 56



MALE/FEMALE
PAGE 56

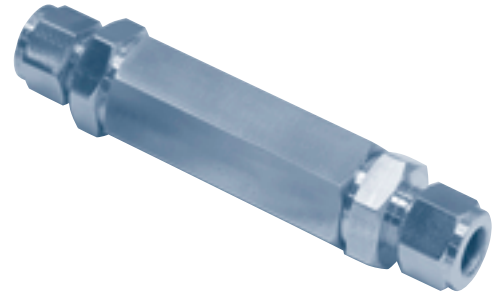

COMPRESSION ENDS
PAGES 57 & 58

Other Valves



MINI CHECK VALVES
PAGE 59



RELIEF VALVES
PAGE 61



INLINE TEE FILTER
PAGE 67

The Waverley brownall range of 316 stainless steel Ball Valves are available in 1000lb, 3000lb or 6000lb class with probably the most comprehensive range of thread forms and end connections in the World.

The BV series 316 bar stock valves are designed to be compact and reliable, and are manufactured in the UK to the most exacting standards. The size range extends from 1/4" (6mm) to 1" (25mm) in BSP, BSPT and NPT thread form plus either single (Duoloc) or twin (Ringlok) ferrule compression ends.

The Waverley brownall low cost range of cast 316 Ball Valves are rated to 1000psi and are available in single piece reduced bore or two and three piece full bore models. The size range extends from 1/4" to 2" in all body types.



Benefits, applications and design features

Features

- 90° fast actuation
- Low operating torque
- Compact one piece design
- Bi-directional flow
- Replaceable seats
- Temperature rating -45 – 230°C
- Up to 1,000psi
- Colour coded handle
- Anti blow out spindle

Applications

- Low pressure shut off
- Drain valve
- Compressed air service
- liquid or vapour service

Benefit

PVC sleeve colour coded for pressure rating 1000psi - Red

Handle pressed from 304 Stainless Steel for corrosion resistance and long life with 90° positive stop.

Lockable handles or pneumatically operated actuators can be supplied fully assembled, with the Waverley brownall 1000 class valve range.

One piece anti-blow out spindle incorporated into the design ensuring safety and seal integrity. An anti-vibration nyloc nut is incorporated on the spindle

Body manufactured from hexagon bar stock in 316 stainless steel as standard.

Ball is manufactured from 316 stainless steel to give material continuity throughout the valve.

It is of a floating ball arrangement, which compensates for seat wear and fluctuations in pressure and temperature.

BV 1000 seats are manufactured from PTFE and are easily renewable.



Technical specifications

Technical specifications

Pressure range	0-1000psi	
Temperature range	-45 to 230°C	
Cv rating (ball orifice diameter)		
Valve size	Cv	Orifice
1/4"	0.72	(0.375")
3/8"	2.30	(0.375")
1/2"	3.00	(0.375")
3/4"	6.30	(0.600")
1"	9.00	(0.600")

Materials of construction

Body	316 stainless steel
Ball	316 stainless steel
Spindle	316 stainless steel
Spindle seal	PTFE glass filled
Spindle washer	PTFE
Retainer	316 stainless steel
Handle	304 stainless steel
Belleville washer	316 stainless steel
Nyloc nut	316 stainless steel
Handle sleeve	PVC
Ball seats	PTFE

Valve markings

Make or manufacturer	Waverley
Pressure rating	1000psi
Cast code	ABC123

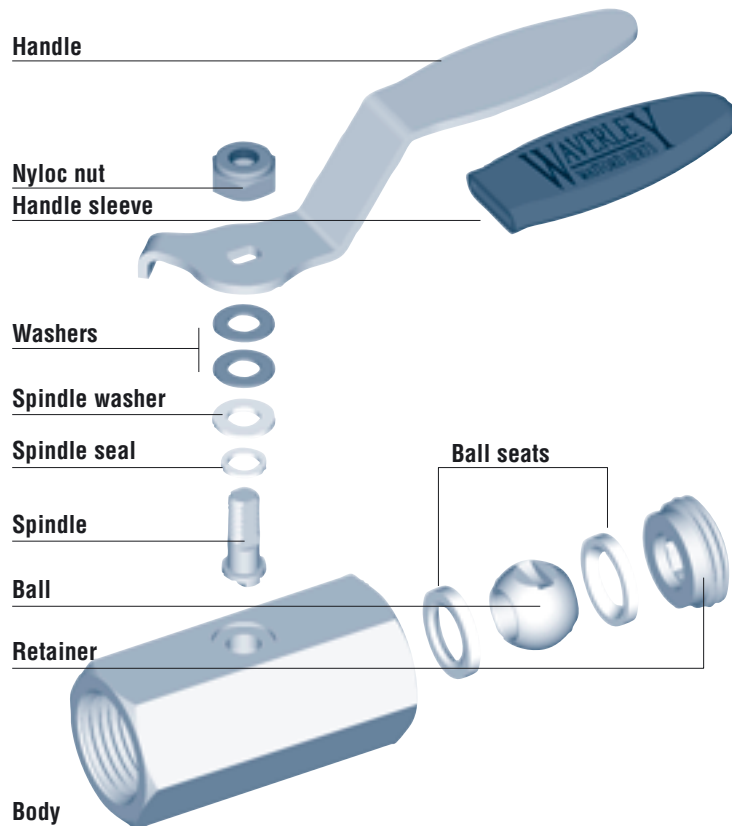

Testing

All Waverley ball valves are 100% tested for sealing performance based on BS 6755 Pt1. These tests consist of: Low pressure (50 psi 3.5 bar) High pressure shell (1,500psi 103.5 Bar)

Seal kits

Seal kits are supplied for necessary maintenance. These consist of ball seats and spindle seals.

Cleaning and packaging

All Waverley ball valves are dispatched fully degreased and sealed. Cleaning for oxygen use on application.

Air flow

- 1/4" valve
- 3/8" valve
- 1/2" valve
- - 3/4" valve
- 1" valve

pressure drop psi

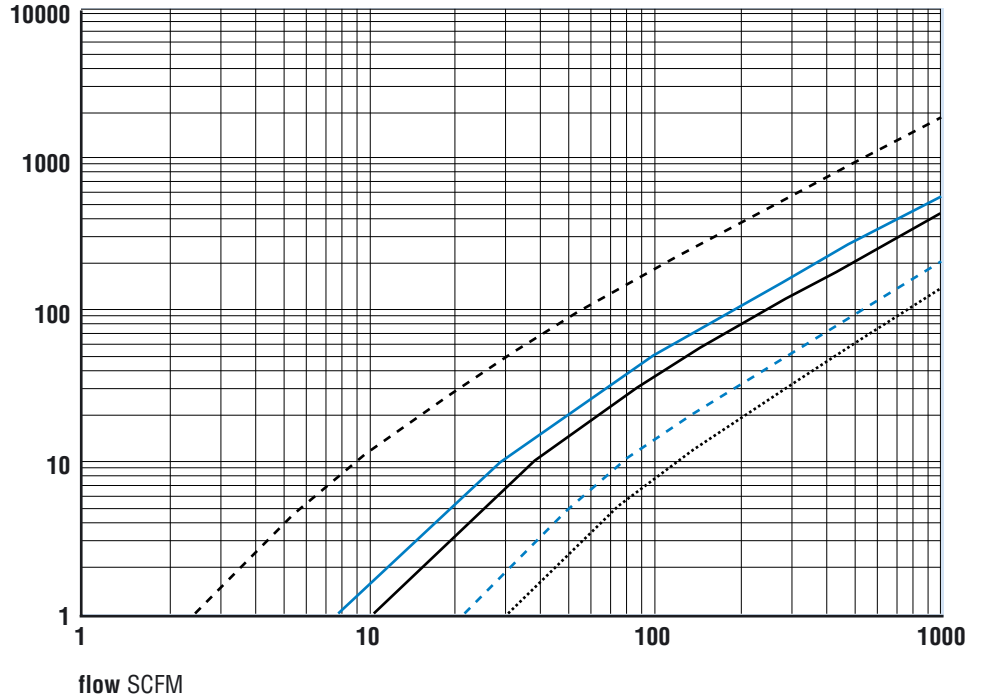

Water flow

- 1/4" valve
- 3/8" valve
- 1/2" valve
- - 3/4" valve
- 1" valve

pressure drop psi

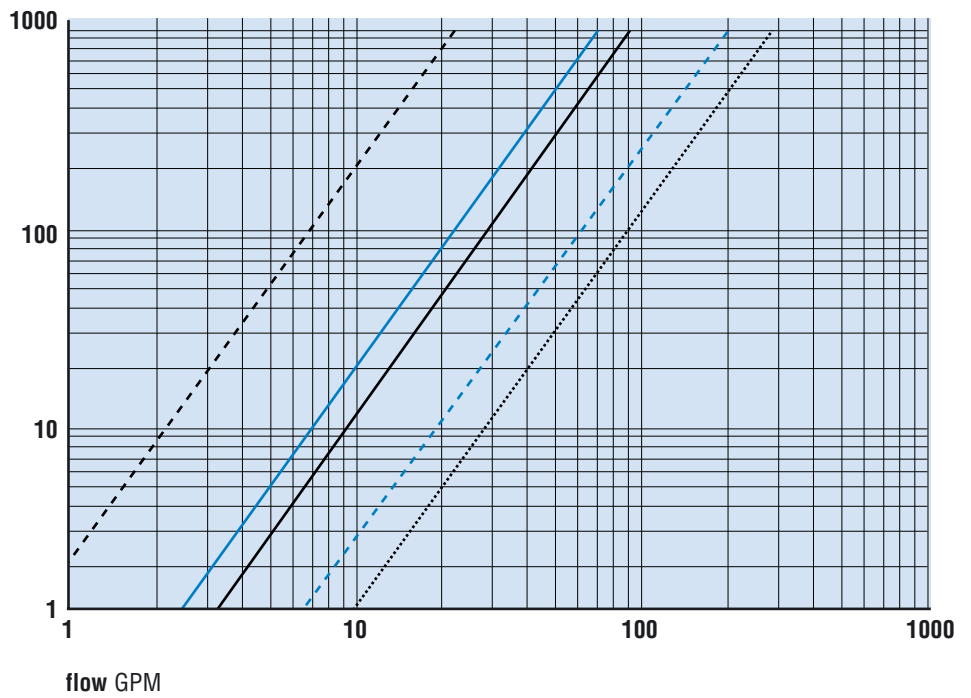

Pressure vs temperature performance

pressure psi

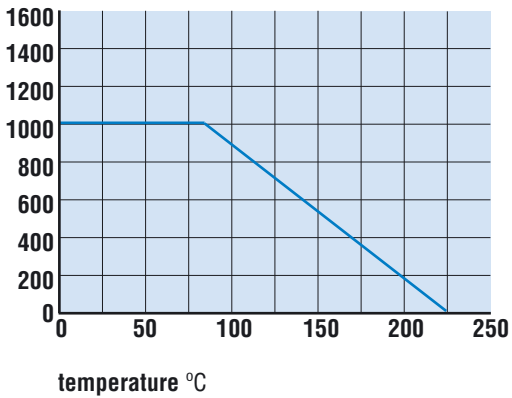

BV 1000 SERIES BALL VALVES

Female/female 1000lb class

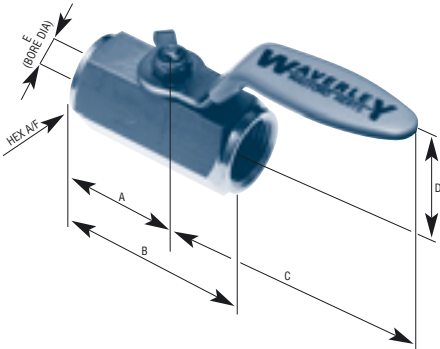

thread size	part number	A	B	C	D	E	hex A/F
G 1/4" BSP	BV2P	0.750"	1.657"	2.375"	1.175"	0.200"	0.750"
G 3/8" BSP	BV3P	0.855"	1.810"	3.225"	1.500"	0.300"	0.875"
G 1/2" BSP	BV4P	1.082"	2.165"	3.250"	1.650"	0.355"	1.062"
G 3/4" BSP	BV6P	1.180"	2.600"	4.100"	2.000"	0.500"	1.300"
G 1" BSP	BV8P	1.675"	3.100"	4.100"	2.100"	0.610"	1.670"
Rc 1/4" BSPT	BV2T	0.750"	1.575"	2.375"	1.175"	0.200"	0.669"
Rc 3/8" BSPT	BV3T	0.855"	1.775"	3.225"	1.500"	0.300"	0.875"
Rc 1/2" BSPT	BV4T	1.082"	2.160"	3.250"	1.650"	0.355"	1.062"
Rc 3/4" BSPT	BV6T	1.180"	2.400"	4.100"	2.000"	0.500"	1.300"
Rc 1" BSPT	BV8T	1.437"	2.950"	4.100"	2.100"	0.610"	1.500"
Rc 1 1/2" BSPT	BV12T	1.800"	3.550"	5.950"	2.750"	0.950"	2.175"
Rc 2" BSPT	BV16T	2.125"	4.250"	5.950"	3.125"	1.250"	2.775"
1/4" NPTF	BV2N	0.750"	1.575"	2.375"	1.175"	0.200"	0.669"
3/8" NPTF	BV3N	0.855"	1.775"	3.225"	1.500"	0.300"	0.875"
1/2" NPTF	BV4N	1.082"	2.160"	3.250"	1.650"	0.355"	1.062"
3/4" NPTF	BV6N	1.180"	2.400"	4.100"	2.000"	0.500"	1.300"
1" NPTF	BV8N	1.437"	2.950"	4.100"	2.100"	0.610"	1.500"

BSP Parallel valves are counter bored in the end faces to accept PTFE O-rings (which are supplied) to act as sealing face.

Male/female 1000lb class

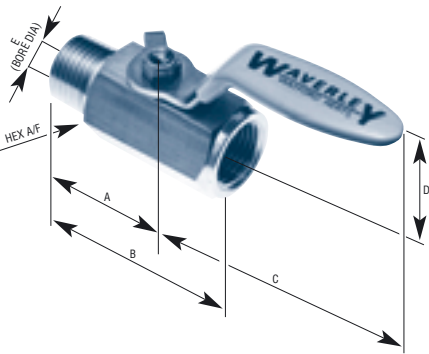

thread size	part number	A	B	C	D	E	hex A/F
R 1/4" BSPT	BV2 M/F	1.000"	1.812"	2.375"	1.175"	0.200"	0.669"
R 3/8" BSPT	BV3 M/F	1.275"	2.185"	3.225"	1.500"	0.300"	0.875"
R 1/2" BSPT	BV4 M/F	1.350"	2.440"	3.250"	1.650"	0.355"	1.062"
R 3/4" BSPT	BV6 M/F	1.525"	2.750"	4.100"	2.000"	0.500"	1.300"
R 1" BSPT	BV8 M/F	1.750"	3.250"	4.100"	2.100"	0.610"	1.500"
1/4" NPTF	BV2N M/F	1.000"	1.812"	2.375"	1.175"	0.200"	0.669"
1/2" NPTF	BV4N M/F	1.350"	2.440"	3.225"	1.650"	0.355"	1.062"
3/4" NPTF	BV6N M/F	1.525"	2.750"	4.100"	2.000"	0.500"	1.300"

Male/male 1000lb class

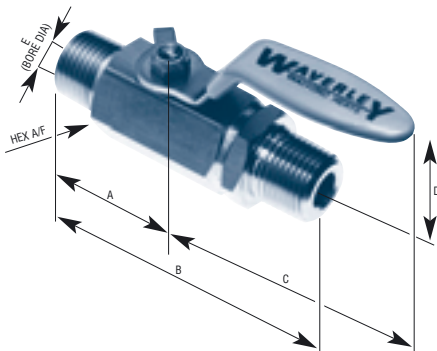

thread size	part number	A	B	C	D	E	hex A/F
R 1/4" BSPT	BV2 M/M	1.000"	2.540"	2.375"	1.175"	0.200"	0.669"
R 3/8" BSPT	BV3 M/M	1.275"	3.000"	3.225"	1.500"	0.300"	0.875"
R 1/2" BSPT	BV4 M/M	1.350"	3.475"	3.250"	1.650"	0.355"	1.062"
R 3/4" BSPT	BV6 M/M	1.525"	3.875"	4.100"	2.000"	0.500"	1.300"
R 1" BSPT	BV8 M/M	1.750"	4.500"	4.100"	2.100"	0.610"	1.500"
1/4" NPTF	BV2N M/M	1.000"	2.540"	2.375"	1.175"	0.200"	0.668"
1/2" NPTF	BV4N M/M	1.350"	3.475"	3.250"	1.650"	0.355"	1.062"
3/4" NPTF	BV6N M/M	1.525"	3.875"	4.100"	2.000"	0.500"	1.300"

BV 1000 SERIES BALL VALVES

Male/straight hose tail 1000lb class

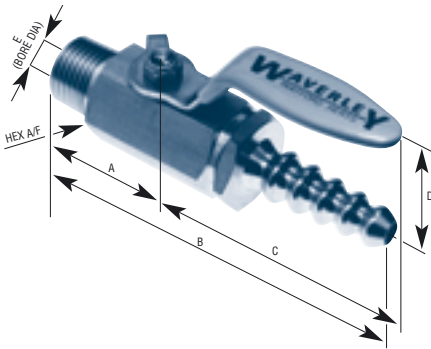

Female/straight hose tail 1000lb class

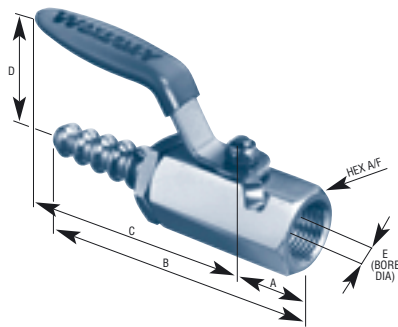

Male 90° hose tail 1000lb class

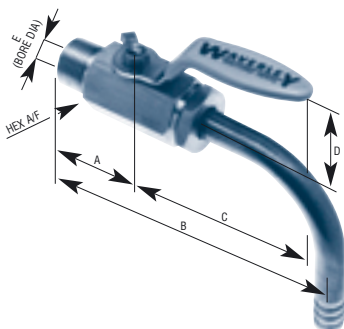

thread size	part number	A	B	C	D	E	hex A/F
R 1/4" BSPT	BV2 M/H	1.000"	2.875"	2.375"	1.175"	0.200"	0.669"
R 3/8" BSPT	BV3 M/H	1.275"	3.687"	3.225"	1.500"	0.300"	0.875"
R 1/2" BSPT	BV4 M/H	1.350"	4.400"	3.250"	1.650"	0.355"	1.062"
R 3/4" BSPT	BV6 M/H	1.525"	5.000"	4.100"	2.000"	0.500"	1.300"
R 1" BSPT	BV8 M/H	1.750"	5.500"	4.100"	2.100"	0.610"	1.670"
1/4" NPTF	BV2N M/H	1.000"	2.875"	2.375"	1.175"	0.200"	0.669"
3/8" NPTF	BV3N M/H	1.275"	3.687"	3.225"	1.500"	0.300"	0.875"
1/2" NPTF	BV4N M/H	1.350"	4.400"	3.250"	1.650"	0.355"	1.062"
3/4" NPTF	BV6N M/H	1.525"	5.000"	4.100"	2.000"	0.500"	1.300"
1" NPTF	BV8N M/H	1.750"	5.500"	4.100"	2.100"	0.610"	1.670"

thread size	part number	A	B	C	D	E	hex A/F
R 1/4" BSPT	BV2 F/H	0.750"	2.625"	2.375"	1.175"	0.200"	0.669"
R 3/8" BSPT	BV3 F/H	0.855"	3.267"	3.225"	1.500"	0.300"	0.875"
R 1/2" BSPT	BV4 F/H	1.082"	4.150"	3.250"	1.650"	0.355"	1.062"
R 3/4" BSPT	BV6 F/H	1.180"	4.655"	4.100"	2.000"	0.500"	1.300"
R 1" BSPT	BV8 F/H	1.437"	5.187"	4.100"	2.100"	0.610"	1.670"
1/4" NPTF	BV2N F/H	0.750"	2.625"	2.375"	1.175"	0.200"	0.669"
3/8" NPTF	BV3N F/H	0.855"	3.267"	3.225"	1.500"	0.300"	0.875"
1/2" NPTF	BV4N F/H	1.082"	4.150"	3.250"	1.650"	0.355"	1.062"
3/4" NPTF	BV6N F/H	1.180"	4.655"	4.100"	2.000"	0.500"	1.300"
1" NPTF	BV8N F/H	1.437"	5.187"	4.100"	2.100"	0.610"	1.670"

thread size	part number	A	B	C	D	E	hex A/F
R 1/4" BSPT	BV2 M/H 90	1.000"	2.250"	2.375"	1.175"	0.200"	0.669"
R 3/8" BSPT	BV3 M/H 90	1.275"	2.750"	3.225"	1.500"	0.300"	0.875"
R 1/2" BSPT	BV4 M/H 90	1.350"	3.500"	3.250"	1.650"	0.355"	1.062"
R 3/4" BSPT	BV6 M/H 90	1.525"	6.300"	4.100"	2.000"	0.500"	1.300"
R 1" BSPT	BV8 M/H 90	1.750"	6.900"	4.100"	2.100"	0.610"	1.670"
1/4" NPTF	BV2N M/H 90	1.000"	2.250"	2.375"	1.175"	0.200"	0.669"
1/2" NPTF	BV4N M/H 90	1.350"	3.500"	3.250"	1.650"	0.355"	1.062"
3/4" NPTF	BV6N M/H 90	1.525"	6.300"	4.100"	2.000"	0.500"	1.300"
1" NPTF	BV8N M/H 90	1.750"	6.900"	4.100"	2.000"	0.500"	1.300"

BV 1000 SERIES BALL VALVES

Female 90° hose tail 1000lb class

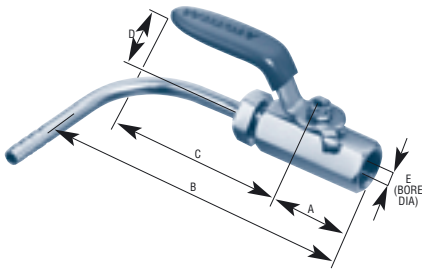

thread size	part number	A	B	C	D	E	hex A/F
R 1/4" BSPT	BV2 F/H 90	0.750"	2.000"	2.375"	1.175"	0.200"	0.669"
R 3/8" BSPT	BV3 F/H 90	0.855"	2.325"	3.225"	1.500"	0.300"	0.875"
R 1/2" BSPT	BV4 F/H 90	1.082"	3.250"	3.250"	1.650"	0.355"	1.062"
R 3/4" BSPT	BV6 F/H 90	1.180"	6.300"	4.100"	2.000"	0.500"	1.300"
R 1" BSPT	BV8 F/H 90	1.437"	6.900"	4.100"	2.100"	0.610"	1.500"
1/4" NPTF	BV2N F/H 90	0.750"	2.000"	2.375"	1.175"	0.200"	0.669"
3/8" NPTF	BV3N F/H 90	0.855"	2.325"	3.225"	1.500"	0.300"	0.875"
1/2" NPTF	BV4N F/H 90	1.082"	3.250"	3.250"	1.650"	0.355"	1.062"
3/4" NPTF	BV6N F/H 90	1.180"	6.300"	4.100"	2.000"	0.500"	1.300"
1" NPTF	BV8N F/H 90	1.437"	6.900"	4.100"	2.100"	0.610"	1.500"

Duoloc® single ferrule OD compression 1000lb class

Length A is from abutment to abutment

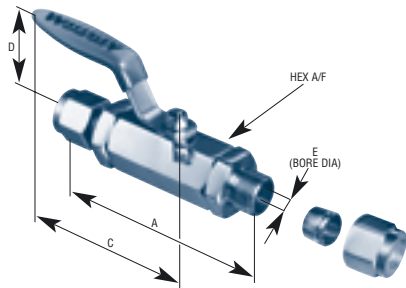

OD tube	part number	A	C	D	E	hex A/F
1/8"	BV1 OD	2.397"	2.375"	1.175"	0.200"	0.750"
3/16"	BV3/16 OD	2.397"	2.375"	1.175"	0.200"	0.750"
1/4"	BV2 OD	2.397"	2.375"	1.175"	0.200"	0.750"
3/8"	BV3 OD	2.614"	3.225"	1.500"	0.300"	0.875"
1/2"	BV4 OD	3.087"	3.250"	1.650"	0.355"	1.062"
3/4"	BV6 OD	3.486"	4.100"	2.000"	0.500"	1.300"
1"	BV8 OD	4.298"	4.100"	2.100"	0.610"	1.670"
6mm	BV6M OD	63.5mm	60mm	31mm	5mm	19mm
8mm	BV8M OD	66.5mm	82mm	42mm	8mm	22mm
10mm	BV10M OD	67mm	82mm	42mm	8mm	22mm
12mm	BV12M OD	76mm	82mm	42mm	9mm	27mm
15mm	BV15M OD	79mm	82mm	42mm	9mm	27mm
16mm	BV16M OD	66mm	82mm	42mm	9mm	27mm
18mm	BV18M OD	93mm	105mm	50mm	12.5mm	33mm
20mm	BV20M OD	95mm	105mm	50mm	12.5mm	33mm
22mm	BV22M OD	95mm	105mm	50mm	12.5mm	33mm
25mm	BV25M OD	108mm	105mm	50mm	12.5mm	33mm

BV 1000 SERIES BALL VALVES

Ringlok® double ferrule OD compression 1000lb class

Length A is from abutment to abutment

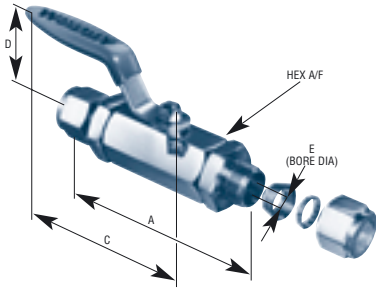

OD tube	part number	A	C	D	E	hex A/F
1/8"	BV1=OD	2.357"	2.375"	1.175"	0.200"	0.750"
3/16"	BV3/16=OD	2.357"	2.375"	1.175"	0.200"	0.750"
1/4"	BV2=OD	2.362"	2.375"	1.175"	0.200"	0.750"
3/8"	BV3=OD	2.512"	3.225"	1.500"	0.300"	0.875"
1/2"	BV4=OD	2.741"	3.250"	1.650"	0.355"	1.062"
3/4"	BV6=OD	3.150"	4.100"	2.000"	0.500"	1.300"
1"	BV8=OD	3.470"	4.100"	2.100"	0.610"	1.670"
6mm	BV6M=OD	59mm	60mm	31mm	5mm	19mm
8mm	BV8M=OD	60mm	82mm	42mm	8mm	22mm
10mm	BV10M=OD	64mm	82mm	42mm	8mm	22mm
12mm	BV12M=OD	70mm	82mm	42mm	9mm	27mm
15mm	BV15M=OD	70mm	82mm	42mm	9mm	27mm
16mm	BV16M=OD	70mm	82mm	42mm	9mm	27mm
18mm	BV18M=OD	80mm	105mm	50mm	12.5mm	33mm
20mm	BV20M=OD	80mm	105mm	50mm	12.5mm	33mm
22mm	BV22M=OD	80mm	105mm	50mm	12.5mm	33mm
25mm	BV25M=OD	90mm	105mm	50mm	12.5mm	33mm

Benefits, applications and design features

Features

- Unique end connection system
- 90° fast actuation
- Low operating torque
- Bi-directional flow
- Replaceable seats
- Temperature rating -45 – 230°C
- Up to 6,000psi
- Colour coded handle
- Anti blow out spindle

Applications

- Hydraulic test equipment
- Pneumatic systems
- Laboratory equipment
- Liquid or vapour services
- Corrosive applications

PVC sleeve colour coded for pressure rating.
3000 psi - Blue
6000 psi - Yellow

Handle pressed from 304 Stainless Steel for corrosion resistance and long life with 90° positive stop.

Lockable handles or pneumatically operated actuators can be supplied fully assembled, with the Waverley brownall 3000 class valve range.

One piece anti-blow out spindle incorporated into design ensuring safety and seal integrity. An anti-vibration nyloc nut is incorporated on the spindle.

Body manufactured from hexagon bar stock in 316 stainless steel as standard. Designed to accept our unique end connections.

Ball is manufactured from 316 stainless steel to give material continuity throughout the valve. It is of a floating ball arrangement, which compensates for seat wear and fluctuations in pressure and temperature.

BV 3,000 and 6,000 seats are manufactured from Peek and are easily renewable.



Technical specifications

Technical specifications

Pressure range	0-3000psi	
	0-6000psi	
Temperature range	-45 to 230°C	
Cv rating (ball orifice diameter)		
Valve	Cv	Orifice
1/4"	5.0	(0.375")
3/8"	5.0	(0.375")
1/2"	5.0	(0.375")
3/4"	14.0	(0.600")
1"	14.0	(0.600")

Materials of construction

Body	316 stainless steel
Ball	316 stainless steel
Spindle	316 stainless steel
Spindle seal	PTFE glass filled
Spindle washer	PTFE
End cap	316 stainless steel
Handle	304 stainless steel
Belleville washer	316 stainless steel
Nyloc nut	316 stainless steel
Handle sleeve	PVC
Ball seat	Peek
Energising seal	PTFE
End cap seal	PTFE

Valve markings

Make or manufacturer	Waverley
Pressure rating	3000, 6000psi
Cast code	ABC

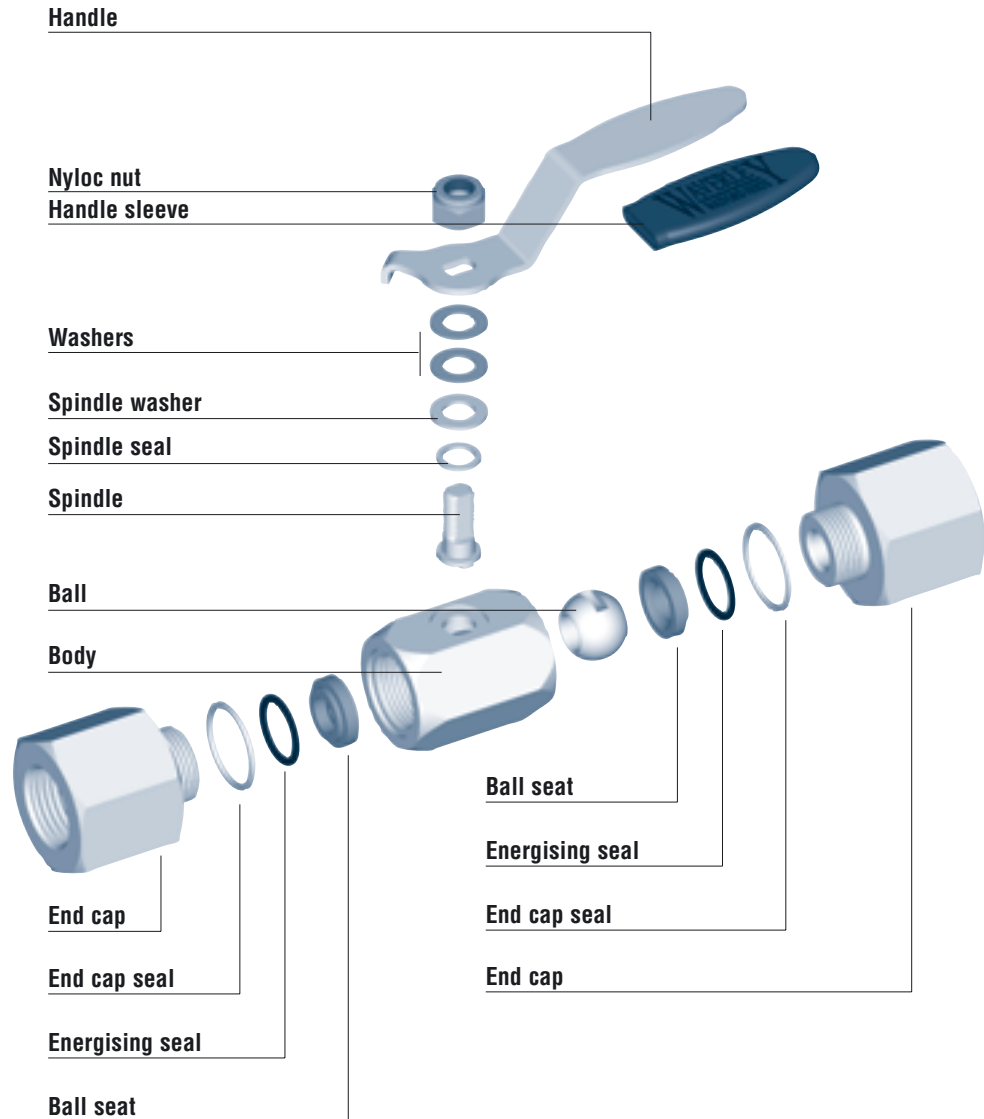

Testing

All Waverley ball valves are 100% tested for sealing performance based on BS 6755 Pt1. These tests consist of: Low pressure (50psi 3.5 bar)
 BV 3000 High pressure shell (4,500psi 310 Bar) BV 6000 High pressure shell (9,000psi 620 Bar).

Seal kits

Seal kits are supplied for necessary maintenance. These consist of ball seats and spindle seals.

Cleaning and packaging

All Waverley ball valves are fully degreased and sealed. Cleaning for oxygen use on application.

Air flow

- 1/4" to 1/2"
- 3/4" to 1"

pressure
drop psi

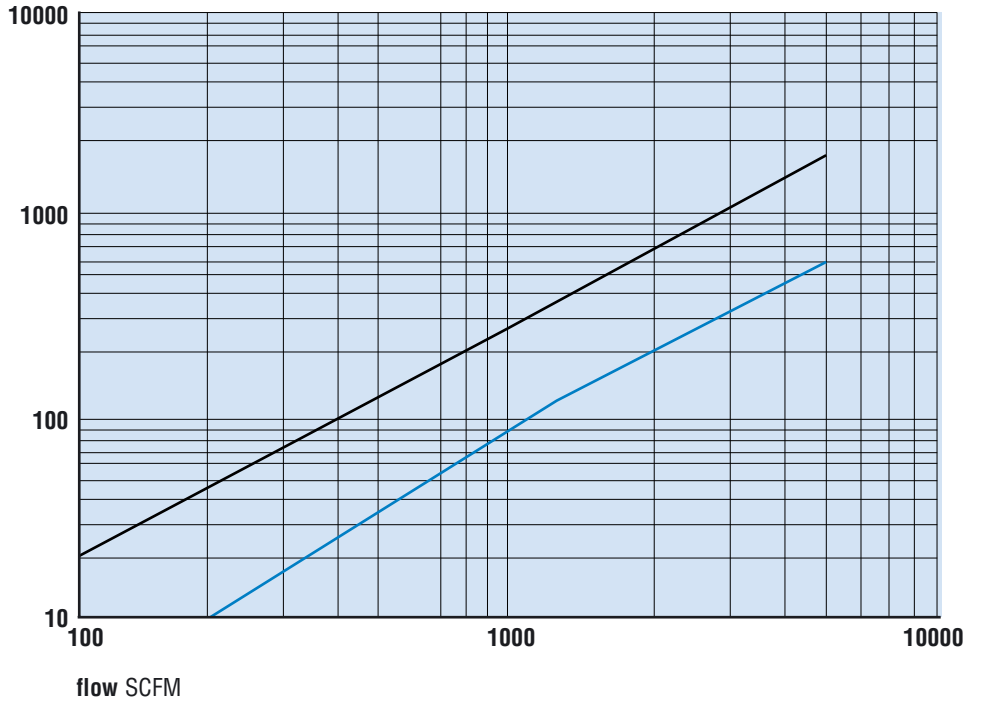

Water flow

- 1/4", 3/8", 1/2"
- 3/4", 1"

pressure
drop psi

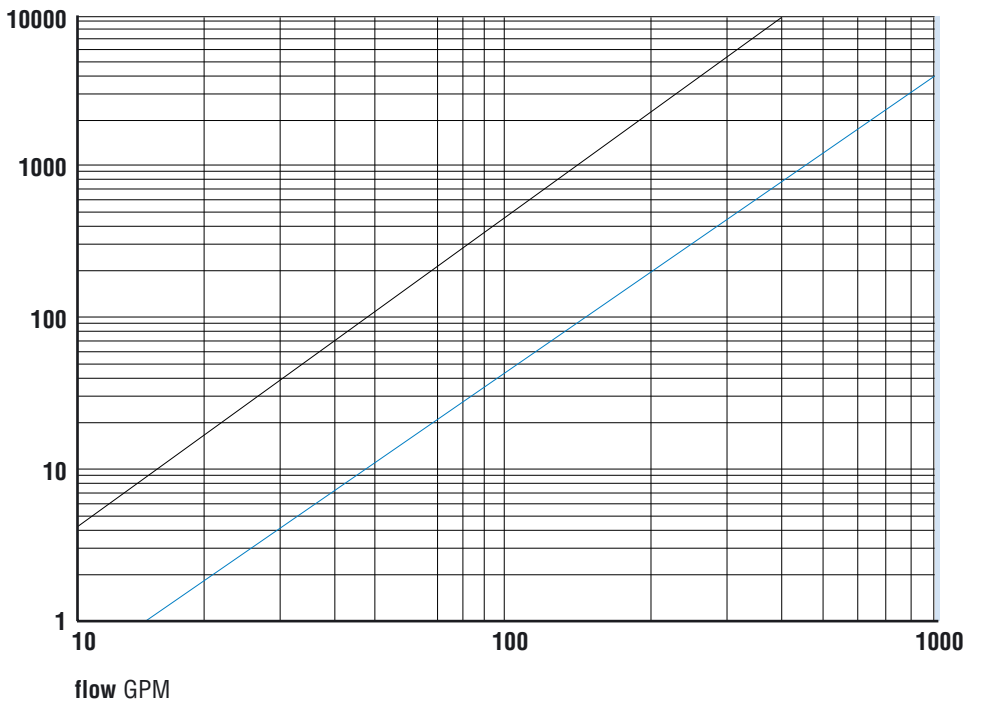

Pressure vs temperature performance

pressure psi
thousands

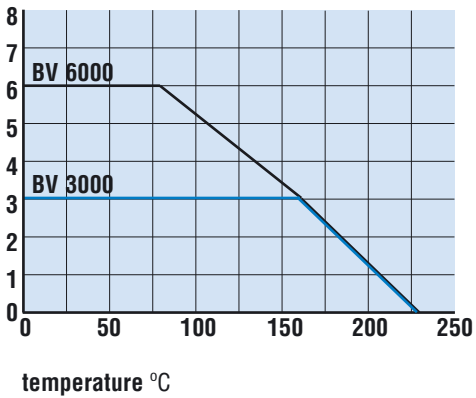

BV 3000 SERIES BALL VALVES

Female/female 3000lb class

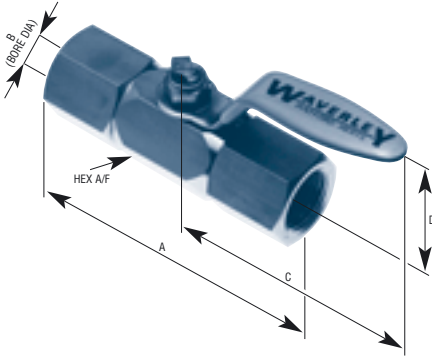

thread size	part number	A	B	C	D	hex A/F
G 1/4" BSP	BV3000/2P	3.060"	0.375"	3.150"	1.772"	1.125"
G 3/8" BSP	BV3000/3P	3.420"	0.375"	3.150"	1.772"	1.125"
G 1/2" BSP	BV3000/4P	3.694"	0.375"	3.150"	1.772"	1.125"
G 3/4" BSP	BV3000/6P	4.341"	0.600"	3.950"	2.175"	1.750"
G 1" BSP	BV3000/8P	4.464"	0.600"	3.950"	2.175"	1.750"
Rc 1/4" BSPT	BV3000/2T	3.200"	0.375"	3.150"	1.772"	1.125"
Rc 3/8" BSPT	BV3000/3T	3.420"	0.375"	3.150"	1.772"	1.125"
Rc 1/2" BSPT	BV3000/4T	3.694"	0.375"	3.150"	1.772"	1.125"
Rc 3/4" BSPT	BV3000/6T	4.335"	0.600"	3.950"	2.175"	1.750"
Rc 1" BSPT	BV3000/8T	4.585"	0.600"	3.950"	2.175"	1.750"
1/4" NPTF	BV3000/2N	3.200"	0.375"	3.150"	1.772"	1.125"
3/8" NPTF	BV3000/3N	3.420"	0.375"	3.150"	1.772"	1.125"
1/2" NPTF	BV3000/4N	3.694"	0.375"	3.150"	1.772"	1.125"
3/4" NPTF	BV3000/6N	4.335"	0.600"	3.950"	2.175"	1.750"
1" NPTF	BV3000/8N	4.585"	0.600"	3.950"	2.175"	1.750"

Male/female 3000lb class

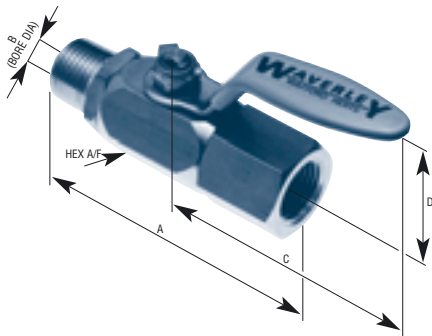

thread size	part number	A	B	C	D	hex A/F
G 1/4" BSP	BV3000/2P MF	2.980"	0.375"	3.150"	1.772"	1.125"
G 3/8" BSP	BV3000/3P MF	3.240"	0.375"	3.150"	1.772"	1.125"
G 1/2" BSP	BV3000/4P MF	3.447"	0.375"	3.150"	1.772"	1.125"
G 3/4" BSP	BV3000/6P MF	4.520"	0.600"	3.950"	2.175"	1.750"
G 1" BSP	BV3000/8P MF	4.630"	0.600"	3.950"	2.175"	1.750"
Rc 1/4" BSPT	BV3000/2T MF	3.100"	0.375"	3.150"	1.772"	1.125"
Rc 3/8" BSPT	BV3000/3T MF	3.210"	0.375"	3.150"	1.772"	1.125"
Rc 1/2" BSPT	BV3000/4T MF	3.534"	0.375"	3.150"	1.772"	1.125"
Rc 3/4" BSPT	BV3000/6T MF	4.515"	0.600"	3.950"	2.175"	1.750"
Rc 1" BSPT	BV3000/8T MF	4.762"	0.600"	3.950"	2.175"	1.750"
1/4" NPTF	BV3000/2N MF	3.100"	0.375"	3.150"	1.772"	1.125"
3/8" NPTF	BV3000/3N MF	3.272"	0.375"	3.150"	1.772"	1.125"
1/2" NPTF	BV3000/4N MF	3.534"	0.375"	3.150"	1.772"	1.125"
3/4" NPTF	BV3000/6N MF	4.515"	0.600"	3.950"	2.175"	1.750"
1" NPTF	BV3000/8N MF	4.762"	0.600"	3.950"	2.175"	1.750"

BV 3000 SERIES BALL VALVES

Male/male 3000lb class

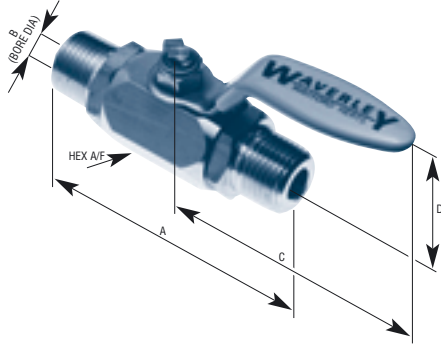

thread size	part number	A	B	C	D	hex A/F
G 1/4" BSP	BV3000/2P M	2.900"	0.375"	3.150"	1.772"	1.125"
G 3/8" BSP	BV3000/3P M	3.060"	0.375"	3.150"	1.772"	1.125"
G 1/2" BSP	BV3000/4P M	3.200"	0.375"	3.150"	1.772"	1.125"
G 3/4" BSP	BV3000/6P M	4.690"	0.600"	3.950"	2.175"	1.750"
G 1" BSP	BV3000/8P M	4.790"	0.600"	3.950"	2.175"	1.750"
R 1/4" BSPT	BV3000/2T M	3.000"	0.375"	3.150"	1.772"	1.125"
R 3/8" BSPT	BV3000/3T M	3.125"	0.375"	3.150"	1.772"	1.125"
R 1/2" BSPT	BV3000/4T M	3.375"	0.375"	3.150"	1.772"	1.125"
R 3/4" BSPT	BV3000/6T M	4.690"	0.600"	3.950"	2.175"	1.750"
R 1" BSPT	BV3000/8T M	4.940"	0.600"	3.950"	2.175"	1.750"
1/4" NPTF	BV3000/2N M	3.000"	0.375"	3.150"	1.772"	1.125"
3/8" NPTF	BV3000/3N M	3.125"	0.375"	3.150"	1.772"	1.125"
1/2" NPTF	BV3000/4N M	3.375"	0.375"	3.150"	1.772"	1.125"
3/4" NPTF	BV3000/6N M	4.690"	0.600"	3.950"	2.175"	1.750"
1" NPTF	BV3000/8N M	4.940"	0.600"	3.950"	2.175"	1.750"

Duoloc® single ferrule OD compression 3000lb class

Length A is from abutment to abutment

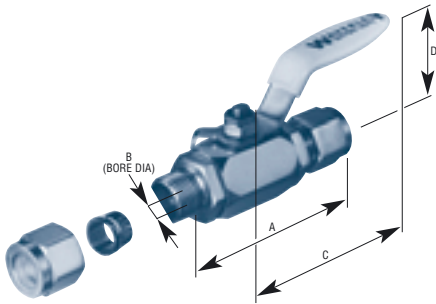

tube OD	part number	A	B	C	D	hex A/F
1/8"	BV3000/10D	2.240"	0.375"	3.150"	1.772"	1.125"
3/16"	BV3000/3/16OD	2.240"	0.375"	3.150"	1.772"	1.125"
1/4"	BV3000/20D	2.240"	0.375"	3.150"	1.772"	1.125"
3/8"	BV3000/30D	2.304"	0.375"	3.150"	1.772"	1.125"
1/2"	BV3000/40D	2.302"	0.375"	3.150"	1.772"	1.125"
3/4"	BV3000/60D	3.564"	0.600"	3.950"	2.175"	1.750"
1"	BV3000/80D	3.752"	0.600"	3.950"	2.175"	1.750"
6mm	BV3000/6MOD	57.5mm	9.5mm	80.0mm	45.0mm	28.6mm
8mm	BV3000/8MOD	56.5mm	9.5mm	80.0mm	45.0mm	28.6mm
10mm	BV3000/10MOD	57.0mm	9.5mm	80.0mm	45.0mm	28.6mm
12mm	BV3000/12MOD	57.0mm	9.5mm	80.0mm	45.0mm	28.6mm
15mm	BV3000/15MOD	57.5mm	9.5mm	80.0mm	45.0mm	28.6mm
16mm	BV3000/16MOD	58.0mm	9.5mm	80.0mm	45.0mm	28.6mm
18mm	BV3000/18MOD	58.5mm	9.5mm	80.0mm	45.0mm	28.6mm
20mm	BV3000/20MOD	90.0mm	15.2mm	100.0mm	55.2mm	44.5mm
22mm	BV3000/22MOD	90.0mm	15.2mm	100.0mm	55.2mm	44.5mm
25mm	BV3000/25MOD	90.0mm	15.2mm	100.0mm	55.2mm	44.5mm

BV 3000 SERIES BALL VALVES

Ringlok® double ferrule OD compression 3000lb class

Length A is from abutment to abutment

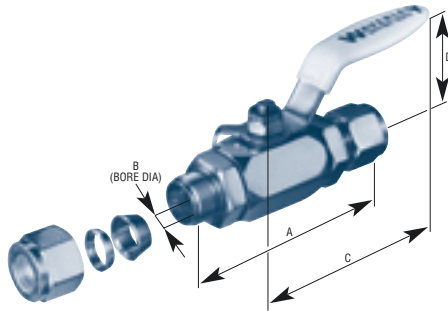

tube OD	part number	A	B	C	D	hex A/F
1/8"	BV3000=10D	2.240"	0.375"	3.150"	1.772"	1.125"
3/16"	BV3000=3/16OD	2.240"	0.375"	3.150"	1.772"	1.125"
1/4"	BV3000=20D	2.240"	0.375"	3.150"	1.772"	1.125"
3/8"	BV3000=30D	2.304"	0.375"	3.150"	1.772"	1.125"
1/2"	BV3000=40D	2.302"	0.375"	3.150"	1.772"	1.125"
3/4"	BV3000=60D	3.564"	0.600"	3.950"	2.175"	1.750"
1"	BV3000=80D	3.752"	0.600"	3.950"	2.175"	1.750"
6mm	BV3000=6MOD	57.5mm	9.5mm	80.0mm	45.0mm	28.6mm
8mm	BV3000=8MOD	56.5mm	9.5mm	80.0mm	45.0mm	28.6mm
10mm	BV3000=10MOD	57.0mm	9.5mm	80.0mm	45.0mm	28.6mm
12mm	BV3000=12MOD	57.0mm	9.5mm	80.0mm	45.0mm	28.6mm
15mm	BV3000=15MOD	57.5mm	9.5mm	80.0mm	45.0mm	28.6mm
16mm	BV3000=16MOD	58.0mm	9.5mm	80.0mm	45.0mm	28.6mm
18mm	BV3000=18MOD	58.5mm	9.5mm	80.0mm	45.0mm	28.6mm
20mm	BV3000=20MOD	90.0mm	15.2mm	100.0mm	55.2mm	44.5mm
22mm	BV3000=22MOD	90.0mm	15.2mm	100.0mm	55.2mm	44.5mm
25mm	BV3000=25MOD	90.0mm	15.2mm	100.0mm	55.2mm	44.5mm

Special design features any combination of ends



With the 3000lb class ball valve range there are two sizes of ball valve body. This enables you to select combinations of ends and sizes
e.g. 1/2" BSPP female x 1/2" OD compression (as shown in photo).

BV 6000 SERIES BALL VALVES

Female/female 6000lb class

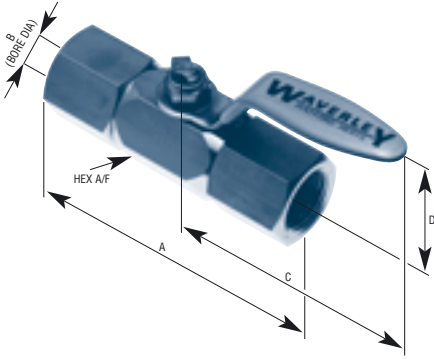

thread size	part number	A	B	C	D	hex A/F
G 1/4" BSP	BV6000/2P	3.060"	0.375"	3.150"	1.772"	1.125"
G 3/8" BSP	BV6000/3P	3.420"	0.375"	3.150"	1.772"	1.125"
G 1/2" BSP	BV6000/4P	3.694"	0.375"	3.150"	1.772"	1.125"
G 3/4" BSP	BV6000/6P	4.341"	0.600"	3.950"	2.175"	1.750"
G 1" BSP	BV6000/8P	4.464"	0.600"	3.950"	2.175"	1.750"
Rc 1/4" BSPT	BV6000/2T	3.200"	0.375"	3.150"	1.772"	1.125"
Rc 3/8" BSPT	BV6000/3T	3.420"	0.375"	3.150"	1.772"	1.125"
Rc 1/2" BSPT	BV6000/4T	3.694"	0.375"	3.150"	1.772"	1.125"
Rc 3/4" BSPT	BV6000/6T	4.335"	0.600"	3.950"	2.175"	1.750"
Rc 1" BSPT	BV6000/8T	4.585"	0.600"	3.950"	2.175"	1.750"
1/4" NPTF	BV6000/2N	3.200"	0.375"	3.150"	1.772"	1.125"
3/8" NPTF	BV6000/3N	3.420"	0.375"	3.150"	1.772"	1.125"
1/2" NPTF	BV6000/4N	3.694"	0.375"	3.150"	1.772"	1.125"
3/4" NPTF	BV6000/6N	4.335"	0.600"	3.950"	2.175"	1.750"
1" NPTF	BV6000/8N	4.585"	0.600"	3.950"	2.175"	1.750"

Male/female 6000lb class

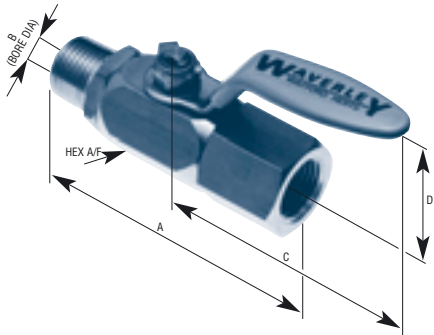

thread size	part number	A	B	C	D	hex A/F
G 1/4" BSP	BV6000/2P MF	2.980"	0.375"	3.150"	1.772"	1.125"
G 3/8" BSP	BV6000/3P MF	3.240"	0.375"	3.150"	1.772"	1.125"
G 1/2" BSP	BV6000/4P MF	3.447"	0.375"	3.150"	1.772"	1.125"
G 3/4" BSP	BV6000/6P MF	4.520"	0.600"	3.950"	2.175"	1.750"
G 1" BSP	BV6000/8P MF	4.630"	0.600"	3.950"	2.175"	1.750"
R 1/4" BSPT	BV6000/2T MF	3.100"	0.375"	3.150"	1.772"	1.125"
R 3/8" BSPT	BV6000/3T MF	3.210"	0.375"	3.150"	1.772"	1.125"
R 1/2" BSPT	BV6000/4T MF	3.534"	0.375"	3.150"	1.772"	1.125"
R 3/4" BSPT	BV6000/6T MF	4.515"	0.600"	3.950"	2.175"	1.750"
R 1" BSPT	BV6000/8T MF	4.762"	0.600"	3.950"	2.175"	1.750"
1/4" NPTF	BV6000/2N MF	3.100"	0.375"	3.150"	1.772"	1.125"
3/8" NPTF	BV6000/3N MF	3.272"	0.375"	3.150"	1.772"	1.125"
1/2" NPTF	BV6000/4N MF	3.534"	0.375"	3.150"	1.772"	1.125"
3/4" NPTF	BV6000/6N MF	4.515"	0.600"	3.950"	2.175"	1.750"
1" NPTF	BV6000/8N MF	4.762"	0.600"	3.950"	2.175"	1.750"

BV 6000 SERIES BALL VALVES

Male/male 6000lb class

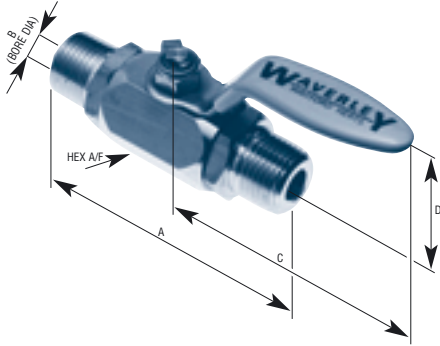

thread size	part number	A	B	C	D	hex A/F
G 1/4" BSP	BV6000/2P M	2.900"	0.375"	3.150"	1.772"	1.125"
G 3/8" BSP	BV6000/3P M	3.060"	0.375"	3.150"	1.772"	1.125"
G 1/2" BSP	BV6000/4P M	3.200"	0.375"	3.150"	1.772"	1.125"
G 3/4" BSP	BV6000/6P M	4.690"	0.600"	3.950"	2.175"	1.750"
G 1" BSP	BV6000/8P M	4.790"	0.600"	3.950"	2.175"	1.750"
R 1/4" BSPT	BV6000/2T M	3.000"	0.375"	3.150"	1.772"	1.125"
R 3/8" BSPT	BV6000/3T M	3.125"	0.375"	3.150"	1.772"	1.125"
R 1/2" BSPT	BV6000/4T M	3.750"	0.375"	3.150"	1.772"	1.125"
R 3/4" BSPT	BV6000/6T M	4.690"	0.600"	3.950"	2.175"	1.750"
R 1" BSPT	BV6000/8T M	4.690"	0.600"	3.950"	2.175"	1.750"
1/4" NPTF	BV6000/2N M	3.000"	0.375"	3.150"	1.772"	1.125"
3/8" NPTF	BV6000/3N M	3.125"	0.375"	3.150"	1.772"	1.125"
1/2" NPTF	BV6000/4N M	3.375"	0.375"	3.150"	1.772"	1.125"
3/4" NPTF	BV6000/6N M	4.690"	0.600"	3.950"	2.175"	1.750"
1" NPTF	BV6000/8N M	4.690"	0.600"	3.950"	2.175"	1.750"

Duoloc® single ferrule OD compression 6000lb class

Length A is from abutment to abutment

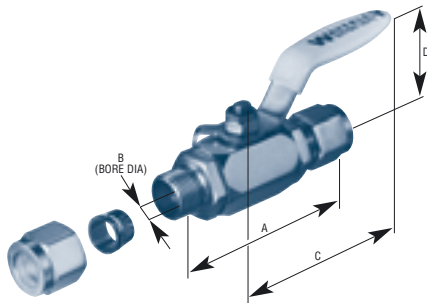

tube OD	part number	A	B	C	D	hex A/F
1/8"	BV6000/10D	2.240"	0.375"	3.150"	1.772"	1.125"
3/16"	BV6000/3/160D	2.240"	0.375"	3.150"	1.772"	1.125"
1/4"	BV6000/20D	2.240"	0.375"	3.150"	1.772"	1.125"
3/8"	BV6000/30D	2.304"	0.375"	3.150"	1.772"	1.125"
1/2"	BV6000/40D	2.302"	0.375"	3.150"	1.772"	1.125"
3/4"	BV6000/60D	3.564"	0.600"	3.950"	2.175"	1.750"
1"	BV6000/80D	3.752"	0.600"	3.950"	2.175"	1.750"
6mm	BV6000/6MOD	57.5mm	9.5mm	80mm	45mm	28.6mm
8mm	BV6000/8MOD	56.5mm	9.5mm	80mm	45mm	28.6mm
10mm	BV6000/10MOD	57mm	9.5mm	80mm	45mm	28.6mm
12mm	BV6000/12MOD	57mm	9.5mm	80mm	45mm	28.6mm
15mm	BV6000/15MOD	57.5mm	9.5mm	80mm	45mm	28.6mm
16mm	BV6000/16MOD	58mm	9.5mm	80mm	45mm	28.6mm
18mm	BV6000/18MOD	58.5mm	9.5mm	80mm	45mm	28.6mm
20mm	BV6000/20MOD	90mm	15.2mm	100mm	55.2mm	44.5mm
22mm	BV6000/22MOD	90mm	15.2mm	100mm	55.2mm	44.5mm
25mm	BV6000/25MOD	90mm	15.2mm	100mm	55.2mm	44.5mm

BV 6000 SERIES BALL VALVES

Ringlok® double ferrule OD compression 6000lb class

Length A is from abutment to abutment

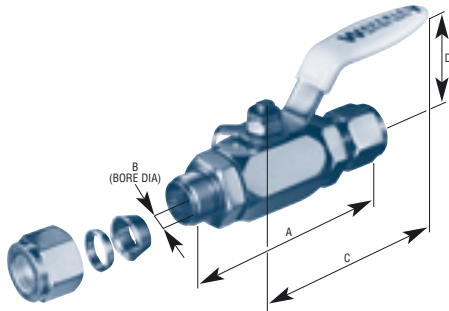

tube OD	part number	A	B	C	D	hex A/F
1/8"	BV6000=10D	2.200"	0.375"	3.150"	1.772"	1.125"
3/16"	BV6000=3/16OD	2.200"	0.375"	3.150"	1.772"	1.125"
1/4"	BV6000=20D	2.204"	0.375"	3.150"	1.772"	1.125"
3/8"	BV6000=30D	2.202"	0.375"	3.150"	1.772"	1.125"
1/2"	BV6000=40D	2.076"	0.375"	3.150"	1.772"	1.125"
3/4"	BV6000=60D	2.990"	0.600"	3.950"	2.175"	1.750"
1"	BV6000=80D	2.934"	0.600"	3.950"	2.175"	1.750"
6mm	BV6000=6MOD	55mm	9.5mm	80mm	45mm	28.6mm
8mm	BV6000=8MOD	56mm	9.5mm	80mm	45mm	28.6mm
10mm	BV6000=10MOD	55mm	9.5mm	80mm	45mm	28.6mm
12mm	BV6000=12MOD	51mm	9.5mm	80mm	45mm	28.6mm
15mm	BV6000=15MOD	50mm	9.5mm	80mm	45mm	28.6mm
16mm	BV6000=16MOD	50mm	9.5mm	80mm	45mm	28.6mm
18mm	BV6000=18MOD	52mm	9.5mm	80mm	45mm	28.6mm
20mm	BV6000=20MOD	76mm	15.2mm	100mm	55.2mm	44.5mm
22mm	BV6000=22MOD	76mm	15.2mm	100mm	55.2mm	44.5mm
25mm	BV6000=25MOD	76mm	15.2mm	100mm	55.2mm	44.5mm

Special design features and combination of ends



With the 6000lb class ball valve range there are two sizes of ball valve body. This enables you to select combinations of ends and sizes e.g. 1/2" BSPP female x 1/2" OD compression (as shown in photo).

LOCKABLE HANDLE BALL VALVES

All of Waverley's 1000lb, 3000lb and 6000lb class Ball Valves can be supplied with lockable handles.

This device allows the valve to be locked in either the open or closed position.

All of the parts used in the locking mechanism are stainless steel.

The locking device is designed to be used with a padlock although these are **not** supplied.

To order lockable handled ball valves:

Select the type of valve required.

Note the part number of the required valve.

Prefix this part number with the letter 'L' (eg. BV2P now becomes LBV2P).



To order lockable handles only

1000lb class	part number
1/4"	LBV2-10
3/8"	LBV3-10
1/2"	LBV4-10
3/4"	LBV6-10
1"	LBV8-10

3000lb/6000lb class	part number
1/4" - 1/2"	LBV6000/4
3/4" + 1"	LBV6000/4A

Waverley brownall offer a range of quality, Cast Ball Valves. They are available as one piece reduced bore valves, plus two and three piece full bore valves. All models are available ex-stock in sizes ranging from 1/4" up to 2". These valves have a safe working pressure of 1000 psi with water or gas applications.

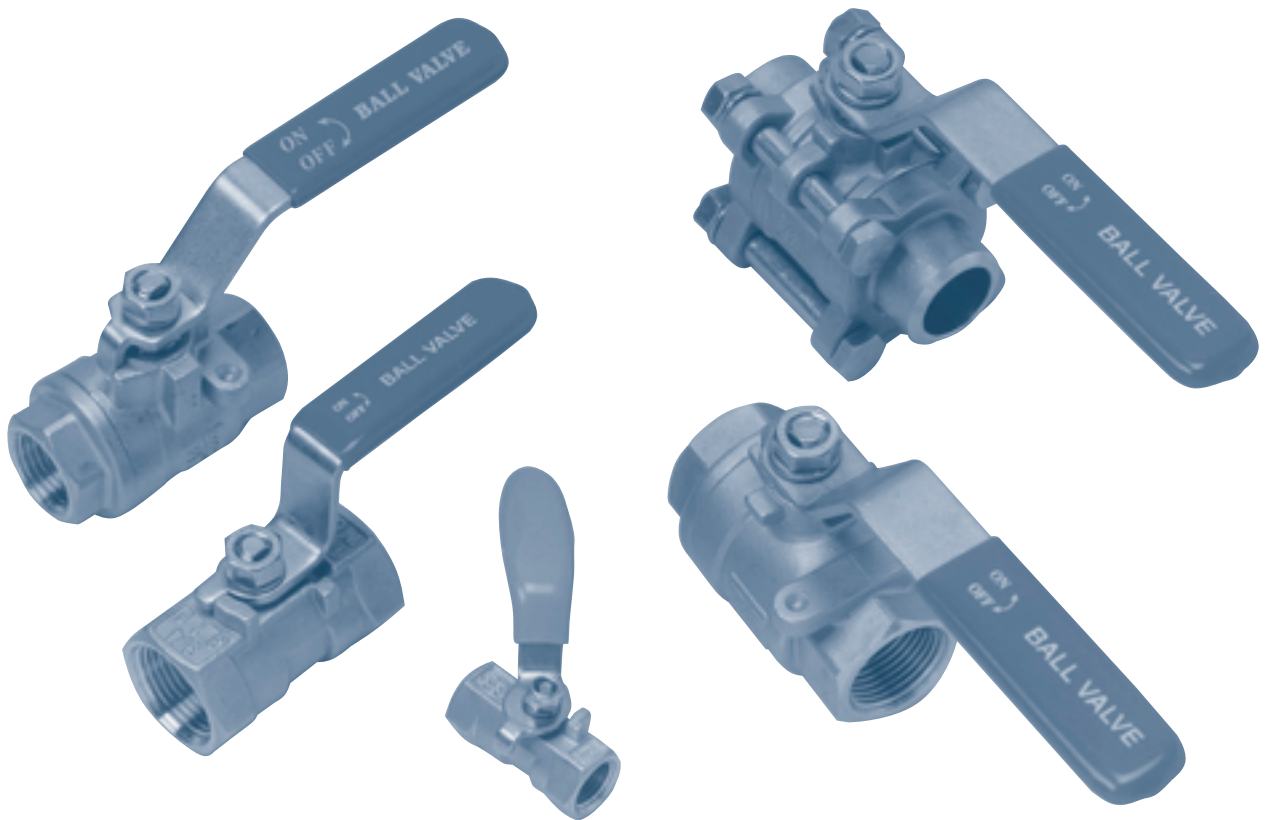

1 Piece Stainless Steel Ball Valve

- Reduced bore
- Investment cast body
- Blow out proof stem
- Material: ASTM A351 CF8M/CF8
ASTM A216 WCB
- 1000 PSI (69 BAR) WOG
- Threaded end connections (BSPT)
- Locking handle
- Size: ¼" – 2"



Dimensions

Size	Part No	d	L	D	H
¼"	BV2LC	5	39	70	26.5
¾"	BV3LC	7	44	80	29
½"	BV4LC	9.2	56.5	92	41
¾"	BV6LC	12.5	59.7	92	45
1"	BV8LC	16	71	110	55
1 ¼"	BV10LC	20	78	104	62.7
1 ½"	BV12LC	24.5	83	138	71
2"	BV16LC	32	100	138	77.4

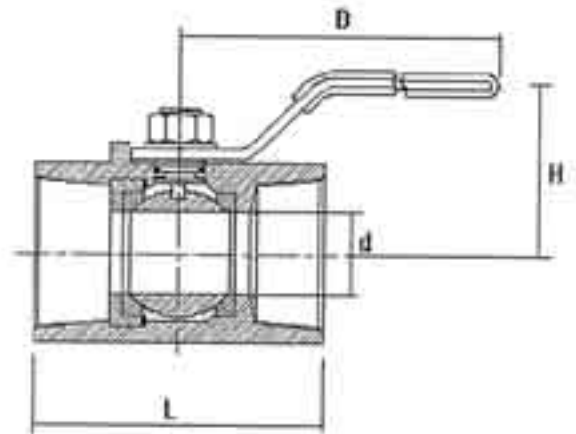

Materials

1	Body	ASTM A351 CF8M
2	Insert	ASTM A276 TYPE 316
3	Ball	ASTM A351 CF8M
4	Ball Seat	PTFE
5	Body Seal	PTFE
6	Stem	ASTM A276 TYPE 316
7	Handle Nut	SS304
8	Washer	SS304
9	Grip	VINYL
10	Handle	SS304
11	Stem Washer	SS304
12	Stem Packing	PTFE
13	Thrust Washer	PTFE

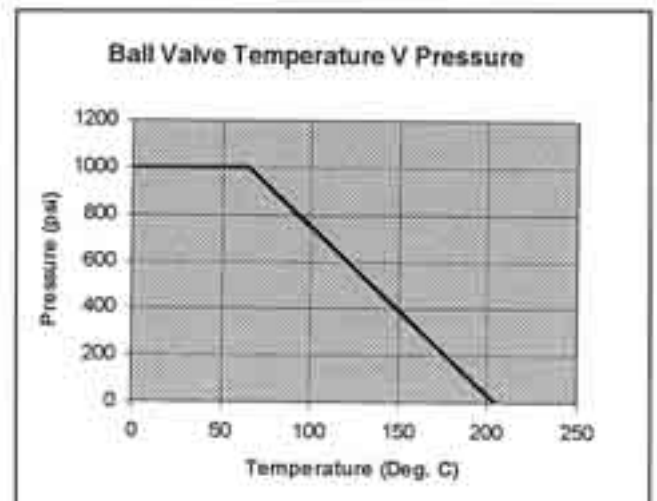

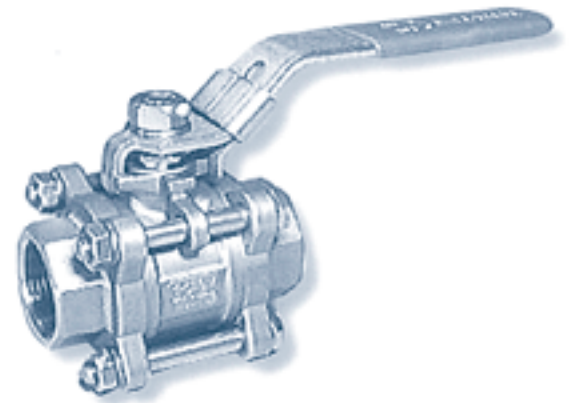

2 Piece Stainless Steel Ball Valve

- Full bore
- Investment cast body
- Blow-out proof stem design
- Working pressure: 1000 PSI (WOG)
- Threaded end connections (BSPT)
- Locking Handle
- Size: 1/4" – 4"

Dimensions

Size	Part No.	A	C	D	E	W1	W2	F	G
1/4"	BV2-2LC	11.6	55	46	108	12.7	28.5	22	28.5
3/8"	BV3-2LC	12.7	55	46	108	12.7	28.5	22	28.5
1/2"	BV4-2LC	15	65	56	108	12.7	28.5	26	34
3/4"	BV6-2LC	20	74	62	132	22.4	35	32.5	40.5
1"	BV8-2LC	25	88	70	160	22.4	35	40	48
1 1/4"	BV10-2LC	32	102	78	160	25.4	38.1	49	59.5
1 1/2"	BV12-2LC	38	110	92	195	25.4	38.1	55	70
2"	BV16-2LC	50	125	102	195	25.4	38.1	69	86.5
2 1/2"	BV20-2LC	65	162	140	270	35	58	85.5	112
3"	BV24-2LC	80	178	148	270	35	58	101	135
4"	BV32-2LC	100	280	175	295	50	62	132	171

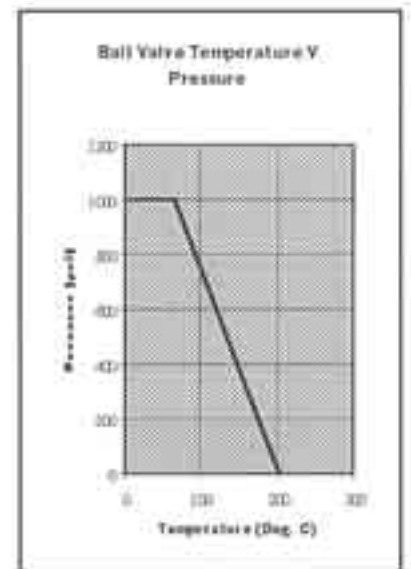

Materials

1	Body	ASTM A351 GR. CF8M
2	Ball	ASTM A351 GR. CF8M
3	Ball Seat	PTFE
4	Body Seal	PTFE
5	End Cap	ASTM A351 GR. CF8M
6	Stem	SS316
7	Thrust Washer	PTFE
8	Stem Packing	PTFE
9	Handle	SS304
10	Gland Nut	SS304
11	Stem Washer	SS304
12	Handle Nut	SS304
13	Grip	VINYL
14	Locking Device	SS304

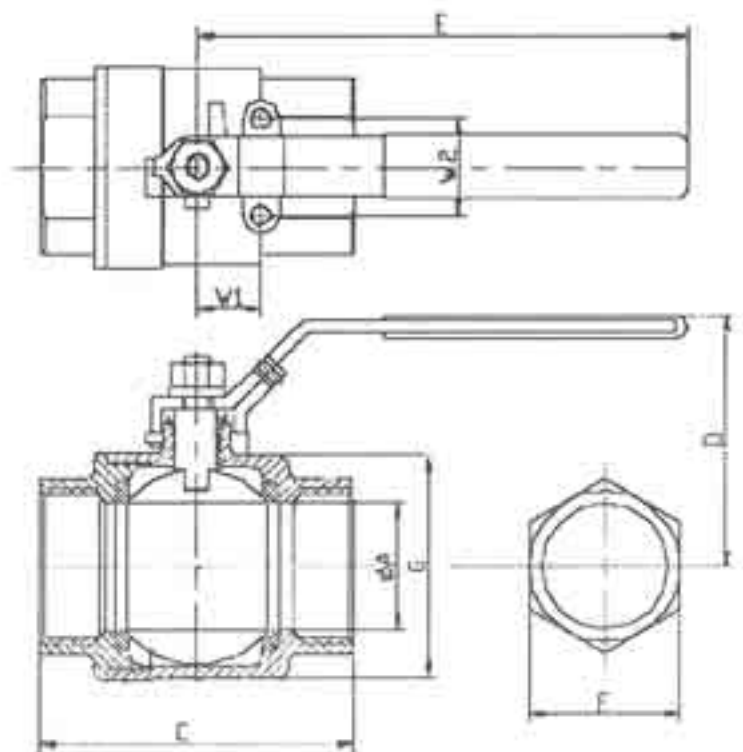

3 Piece Stainless Steel Ball Valve

- Full bore
- Investment cast body
- Blow-out proof stem design
- 1000 PSI (WOG)
- Threaded ends (BSPT)
- Locking device
- Size: 1/4" – 4"

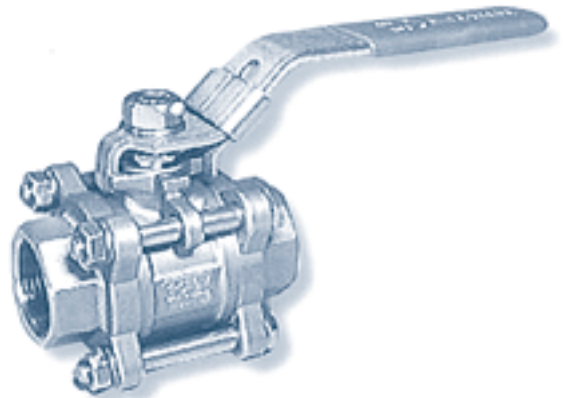

Dimensions

Size	Part Number	d	L	D	H
1/4"	BV2-3LC	11.6	62	102	44
3/8"	BV3-3LC	12.7	62	102	44
1/2"	BV4-3LC	15	66	130	50
3/4"	BV6-3LC	19	78	130	58
1"	BV8-3LC	25	86	153	73
1 1/4"	BV10-3LC	32	103	153	78
1 1/2"	BV12-3LC	38	120	182	82
2"	BV16-3LC	50	135	182	91
2 3/4"	BV20-3LC	65	165	230	115
3"	BV24-3LC	80	182	230	125
4"	BV32-3LC	100	230	280	173

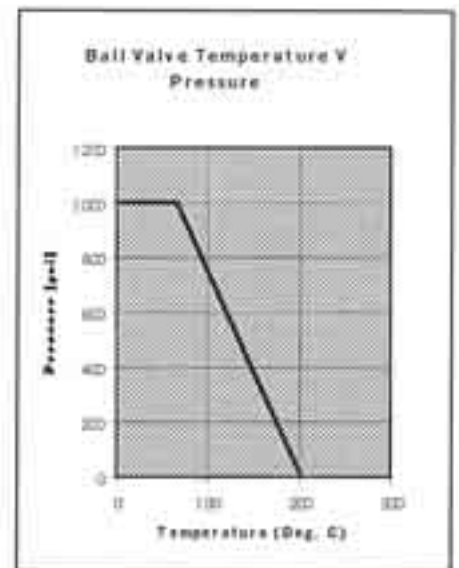

Materials

1	Body	ASTM A351 CF8M
2	Ball Seat	PTFE
3	End Cap	ASTM A351 CF8M
4	Ball	ASTM A351 CF8M
5	Stem	SS316
6	Nut	SS304
7	Bolt Washer	SS304
8	Grip	VINYL
9	Handle	SS304
10	Handle Nut	SS304
11	Washer	SS304
12	Gland Nut	SS304
13	Stem Packing	PTFE
14	Thrust Washer	PTFE
15	Body Seal	PTFE
16	Bolt	SS304

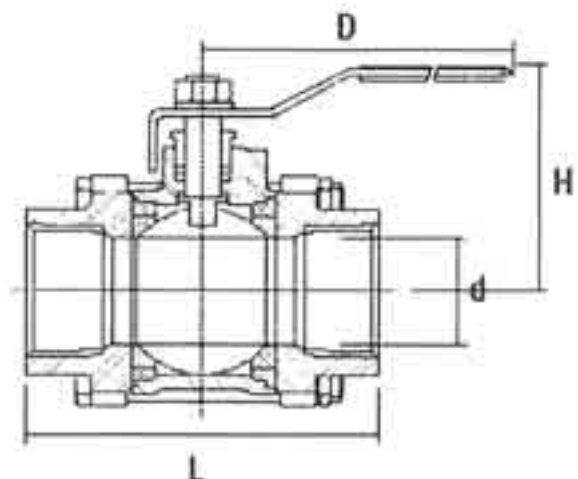
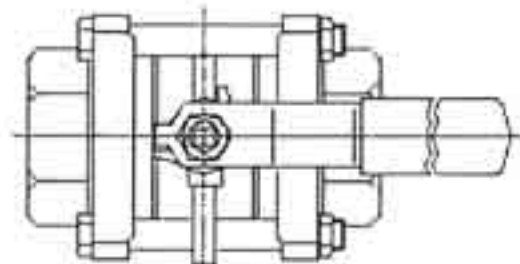

The Waverley brownall series of T and L ported high pressure diverting ball valve range offers a compact and safe way to divert, control, and vent high pressure liquid or gases. They combine multidirectional flow with shutoff capacity in one valve. These all Stainless Steel valves have a safe working pressure of 6000 psi and are available in sizes ranging from 1/4" to 1/2".

Design Availability.

3 Way TEE Port Bottom Entry.
Allows Flow Diversion and Isolation



3 Way L Port Side Entry
Allows Flow Diversion



3 Way TEE Ported Side Entry



Design Features.

- Robust High Pressure Design.
- Multi Inlet Design
- Blow Out Proof Stem.
- Floating Ball and Seats.
- Low Operating Torque
- Wide Range of End Connections
- Replaceable Seats and Seals
- Full Material Traceability
- Panel Mounting Option
- Lever or Pointer Handle



Side Entry Design

Part	Material
Body	316 St ST
End Connections	316 St ST
Ball	316 St ST
Stem	316 St ST
Stem Seal	RTFE
Seats	PTFE / PVDF
Top Seal	RTFE
Body Seal	PTFE / PVDF
Pin	316 St ST
Lever Handle	316 St ST
Pointer Handle	MAZAK
Handle Sleeve	PVC
Nut	A4 ST ST
Washer	A4 ST ST
Spacer	316 St ST
Seal Energiser	VITON

3 Way Ball Valve Female Outlet

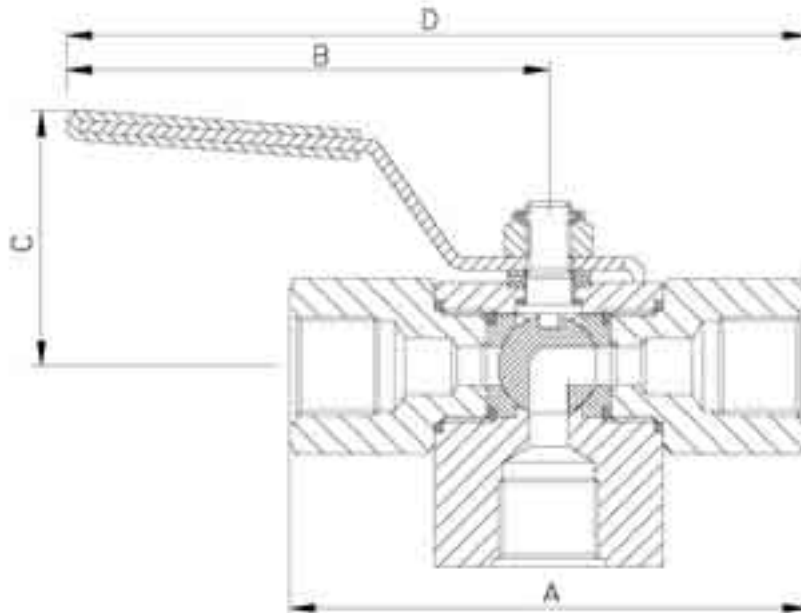

Thread	Entry	Pt No (L Port)	Pt No (T Port)	Dim A	Dim B	Dim C	Dim D
1/4 NPT	Bottom	3BV-2N-F-BE	N/A	2.80	4.53	1.77	5.93
3/8 NPT	Bottom	3BV-3N-F-BE	N/A	3.03	4.53	1.77	6.04
1/2 NPT	Bottom	3BV-4N-F-BE	N/A	3.35	4.53	1.77	6.20
1/4 BSPT	Bottom	3BV-2T-F-BE	N/A	2.80	4.53	1.77	5.93
3/8 BSPT	Bottom	3BV-3T-F-BE	N/A	3.03	4.53	1.77	6.04
1/2 BSPT	Bottom	3BV-4T-F-BE	N/A	3.35	4.53	1.77	6.20
1/4 BSP	Bottom	3BV-2P-F-BE	N/A	2.80	4.53	1.77	5.93
3/8 BSP	Bottom	3BV-3P-F-BE	N/A	2.95	4.53	1.77	6.00
1/2 BSP	Bottom	3BV-4P-F-BE	N/A	3.27	4.53	1.77	6.16
1/4 NPT	Side	3BV-2N-F-SE	3BV-2N-F-SE-T	2.80	4.53	1.77	5.93
3/8 NPT	Side	3BV-3N-F-SE	3BV-3N-F-SE-T	3.03	4.53	1.77	6.04
1/2 NPT	Side	3BV-4N-F-SE	3BV-4N-F-SE-T	3.35	4.53	1.77	6.20
1/4 BSPT	Side	3BV-2T-F-SE	3BV-2T-F-SE-T	2.80	4.53	1.77	5.93
3/8 BSPT	Side	3BV-3T-F-SE	3BV-3T-F-SE-T	3.03	4.53	1.77	6.04
1/2 BSPT	Side	3BV-4T-F-SE	3BV-4T-F-SE-T	3.35	4.53	1.77	6.20
1/4 BSP	Side	3BV-2P-F-SE	3BV-2P-F-SE-T	2.80	4.53	1.77	5.93
3/8 BSP	Side	3BV-3P-F-SE	3BV-3P-F-SE-T	2.95	4.53	1.77	6.00
1/2 BSP	Side	3BV-4P-F-SE	3BV-4P-F-SE-T	3.27	4.53	1.77	6.16

3 Way Ball Valve Male Outlet

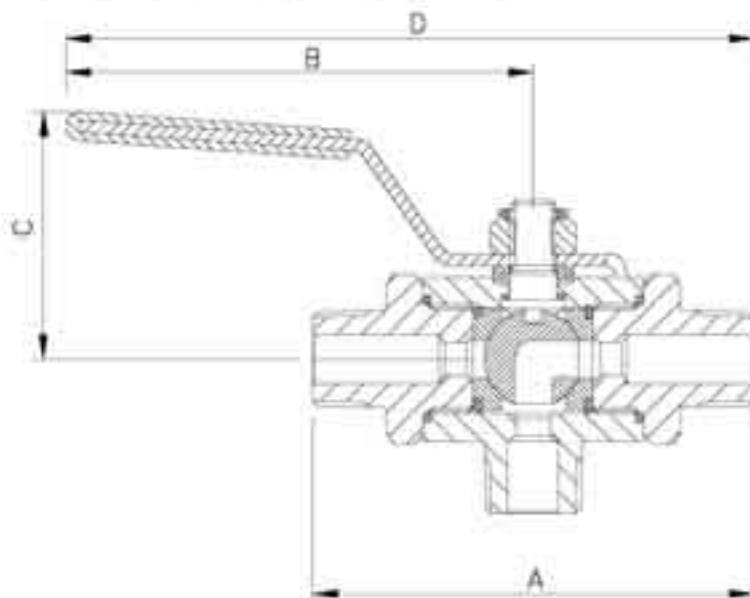

Thread	Entry	Pt No (L Port)	Pt No (T Port)	Dim A	Dim B	Dim C	Dim D
1/4 NPT	Bottom	3BV-2N-M-BE	N/A	2.80	4.53	1.77	5.93
3/8 NPT	Bottom	3BV-3N-M-BE	N/A	3.03	4.53	1.77	6.04
1/2 NPT	Bottom	3BV-4N-M-BE	N/A	3.35	4.53	1.77	6.20
1/4 BSP	Bottom	3BV-2T-M-BE	N/A	2.80	4.53	1.77	5.93
3/8 BSP	Bottom	3BV-3T-M-BE	N/A	3.03	4.53	1.77	6.04
1/2 BSP	Bottom	3BV-4T-M-BE	N/A	3.35	4.53	1.77	6.20
1/4 BSP	Bottom	3BV-2P-M-BE	N/A	2.80	4.53	1.77	5.93
3/8 BSP	Bottom	3BV-3P-M-BE	N/A	2.95	4.53	1.77	6.00
1/2 BSP	Bottom	3BV-4P-M-BE	N/A	3.27	4.53	1.77	6.16
1/4 NPT	Side	3BV-2N-M-SE	3BV-2N-M-SE-T	2.80	4.53	1.77	5.93
3/8 NPT	Side	3BV-3N-M-SE	3BV-3N-M-SE-T	3.03	4.53	1.77	6.04
1/2 NPT	Side	3BV-4N-M-SE	3BV-4N-M-SE-T	3.35	4.53	1.77	6.20
1/4 BSP	Side	3BV-2T-M-SE	3BV-2T-M-SE-T	2.80	4.53	1.77	5.93
3/8 BSP	Side	3BV-3T-M-SE	3BV-3T-M-SE-T	3.03	4.53	1.77	6.04
1/2 BSP	Side	3BV-4T-M-SE	3BV-4T-M-SE-T	3.35	4.53	1.77	6.20
1/4 BSP	Side	3BV-2P-M-SE	3BV-2P-M-SE-T	2.80	4.53	1.77	5.93
3/8 BSP	Side	3BV-3P-M-SE	3BV-3P-M-SE-T	2.95	4.53	1.77	6.00
1/2 BSP	Side	3BV-4P-M-SE	3BV-4P-M-SE-T	3.27	4.53	1.77	6.16

The Waverley brownall range of air actuated ball valves are entirely manufactured in the UK and offer a unique compact design. The actuators are the ideal complement to Waverley's range of 1000lb, 3000lb and 6000lb class valves on previous pages. Waverley brownall's actuated ball valves are sold as complete factory mounted units and offer space saving, corrosion resistance and long maintenance free operation.

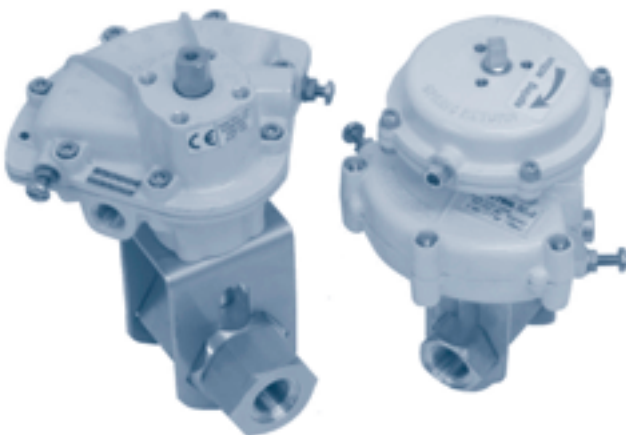

The Waverley brownall actuated ball valves have the following important features:-

- Simple robust design – allowing ease of use and installation.
- Wide range of end connections available including threaded, Ringlok and Duoloc
- Compact and space saving – best torque/size package available.
- Only one moving part on the actuator – allows the simplest and most reliable mechanism for quarter turn actuation.
- Durable corrosion resistant materials. The actuator casing is made from die cast zinc alloy and then epoxy coated.
- Valves are stainless steel.
- Waverley brownall's quality control programme approved to BS EN ISO 9001-2000, and ensures that each unit is manufactured to the highest quality standards and tested before leaving the factory.

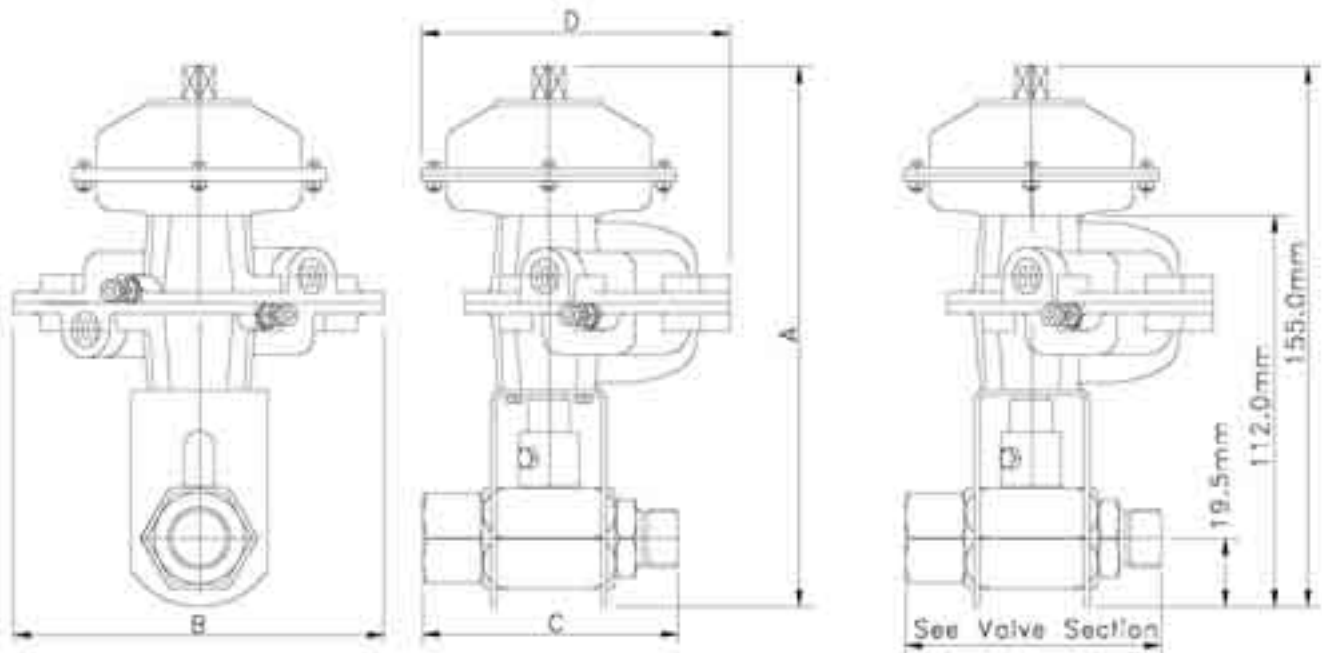

Note The C+D dimensions are not shown for the 3000lb and 6000lb ball valves as these change depending on the end connections.

Valve Selection.

Decide which type of actuator is required and then prefix the standard ball valve part number with one of the following : Standard Double Acting Actuator- 'A' . Actuator fitted with spring return normally closed - 'ASRC'. Actuator fitted with spring re turn normally open - 'ASRO'. (eg BV2P with spring return normally closed = ASRC BV2P)

1000lb Class

	A	B	C	D
1/4"	3.464"	1.260"	1.654"	n/a
3/8"	5.118"	2.795"	1.775"	2.795"
1/2"	5.118"	2.795"	2.160"	2.795"
3/4"	6.614"	3.661"	2.402"	3.740"
1"	6.811"	3.661"	2.952"	3.700"

3000 & 6000lb Class

	A	B	C	D
1/4"	6.425"	3.661"	See Notes	See Notes
3/8"	6.425"	3.661"	See Notes	See Notes
1/2"	6.425"	3.661"	See Notes	See Notes

Featuring the World's most comprehensive range of instrumentation Needle valves. The Waverley brownall Needle valve range is designed and manufactured to the highest standards to meet the requirements of the severe applications anticipated for these valves. They have a split stem design, which ensures accurate seating, and a bubble tight seal. They are general-purpose valves for use on liquid or gas applications where the isolation of flow, equalisation and venting of pressure are the main criteria. The Waverley brownall Needle valve is available ex stock with a variety of end connections from 1/4" to 3/4", giving any combination of ends from NPT, BSPP, BSPT, Single and Twin ferrule OD compression. They are available for applications up to 10,000 psi and temperatures up to 400° C.

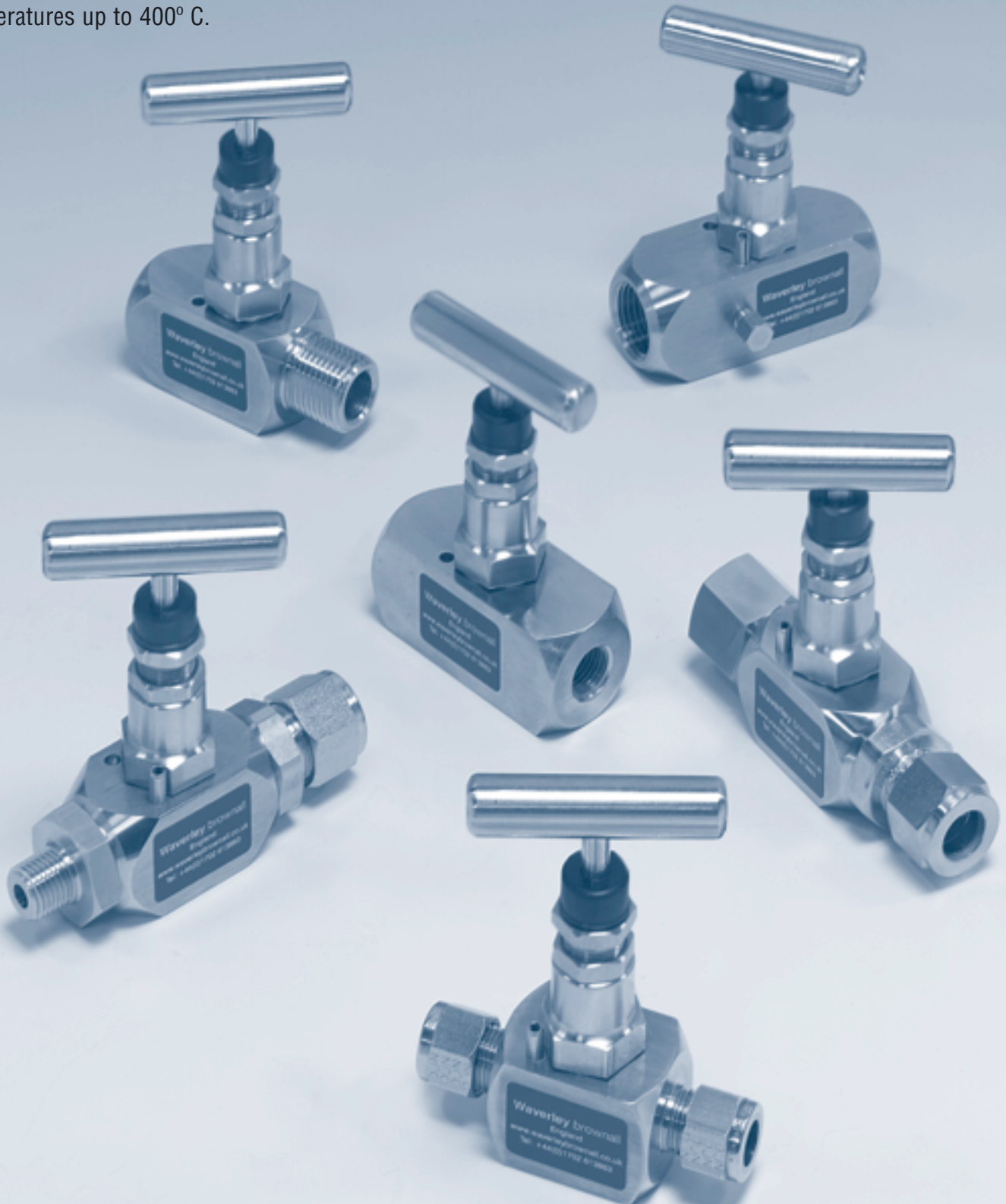

Features

Non rotating ball tip
Provides bubble tight shut off
Metal to metal bonnet seal
Back seating spindle
Prevents spindle blow out or accidental removal whilst in operation
All threads media free
Mirror finish spindle
8 micro inch finish reduces operating torque
Self adjusting shaft seal
Requires no maintenance
Anti-tamper option
Prevents unauthorised operation
Choice of body material
Provides a wide range of valves for many applications
Choice of valve packing
Providing for higher temperature applications

Applications

Instrument line shut off
Gauge and instrument isolation
Drain/vent valve
Up to 10,000 psi and 400°C
liquid or vapour service
Downstream pressure release
In-situ calibration

Options

Sour gas service
Valves can be manufactured to NACE (MR-01-75) standard on request

Oxygen service
Products can be supplied de-greased for oxygen service on request

Panel mount
Valves can also be supplied with a panel mount facility

Trim
316 stainless steel as standard.
17.4PH as option

Anti-tamper
To prevent unauthorised operation of the valve

Benefits

'T' Bar handle made from 304 or 316 stainless steel. Fastened to the spindle by a dowel type 304 or 316 stainless steel locking screw.

Colour coded dust cap protects the stem threads.

Close tolerance gland pusher allows packing adjustment whilst in service.

Gland lock-nut ensures the gland nut is positively located.

Close tolerance gland yoke precision machined from 316 stainless steel.

Gland packing is PTFE as standard for temperatures up to 200°C. Graphite seals are standard for temperatures up to 400°C.

Spindle produced from 316 stainless steel.

Split stem design ensures accurate seating and bubble tight seal.

Locking pin made from 304 stainless steel ensures that the correct assembly torque of the valve head is maintained against the effects of vibration and/or temperature.

Bonnet precision machined from 316 stainless steel, housing the gland packing below the actuating threads.

Non-rotating trim made from 316 stainless steel, precision machined with spherical end to ensure a bubble tight seal.

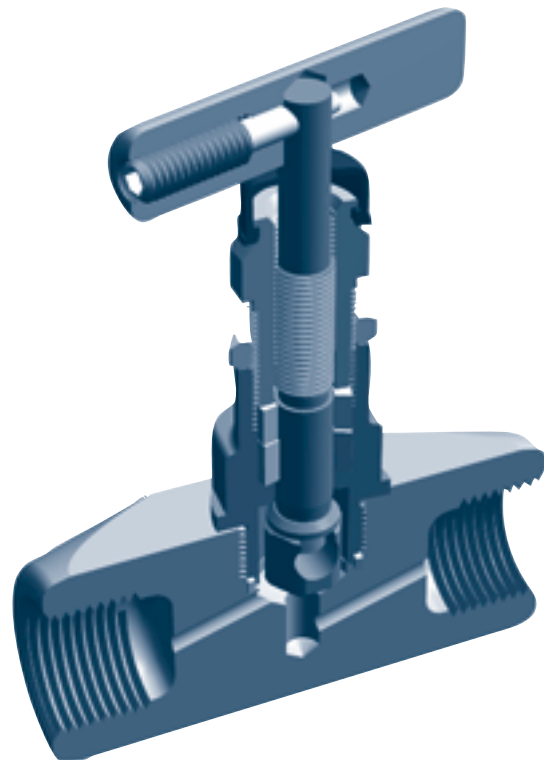

Technical specifications

Pressure range	0-6000psi
Extended range	0-10,000psi
Temperature range (PTFE)	-20 to 200°C
Temperature range (Graphite)	-20 to 400°C
Factor of safety	4:1
Seat type	Metal to metal
CV rating (Open) 0.30	
Orifice	3.80mm

Materials of construction

Handle	304 stainless steel
Lock screw	304 stainless steel
Dust cap	Nylon 6
Spindle	316 stainless steel
Gland adjuster	316 stainless steel PTFE Coated
Lock nut	304 stainless steel
Packing	PTFE
Bonnet	316 stainless steel
Dwell screw (not shown)	304 stainless steel
Keep plate (not shown)	304 stainless steel
Body seal	PTFE
Needle	316 stainless steel
Gland yoke	316 stainless steel

Valve connection standards

NPT	to ANSI/ASME B1-20.3
BSPT	to BS21
BSP	to BS2779

Valve markings

Make or manufacturer	Brownall Precision
Model number	P1/W4W4TBOXH
Operating limits	6000 psi @200°C
Material of construction	316
Material cast code	A123
Operating schematic or polarity arrow	
Colour coded dust cap Blue	Isolate
Packing material T	PTFE
Packing material G	Graphite
Valve identification	Isolate

Testing

All Needle Valves are 100% tested with reference to BS122-1:2003.

A shell test is at 1.5 x maximum working pressure and the seat test at 1.1 x maximum working pressure.

'T' Bar handle

Lock screw

Dust cap

Gland adjuster

Spindle

Lock nut

Gland yoke

Gland packing

Bonnet

Body seal

Needle

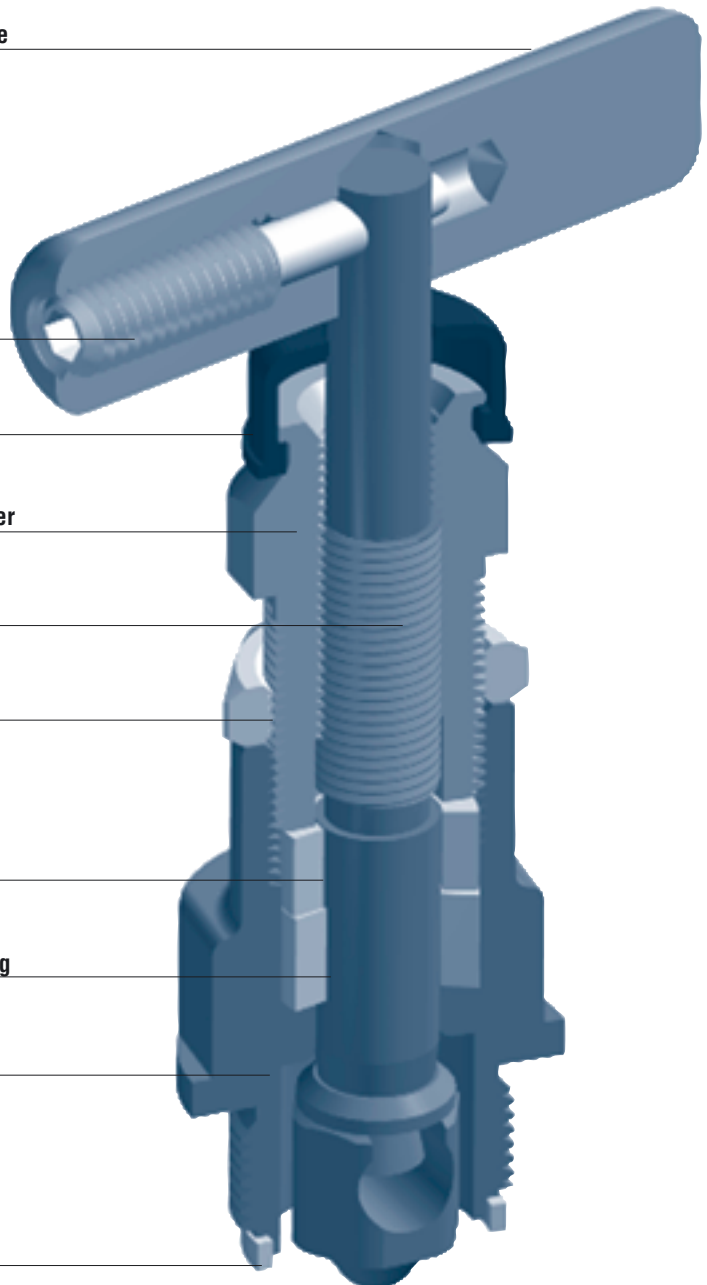

Pressure vs temperature performance

- PTFE seals
- Graphite seals

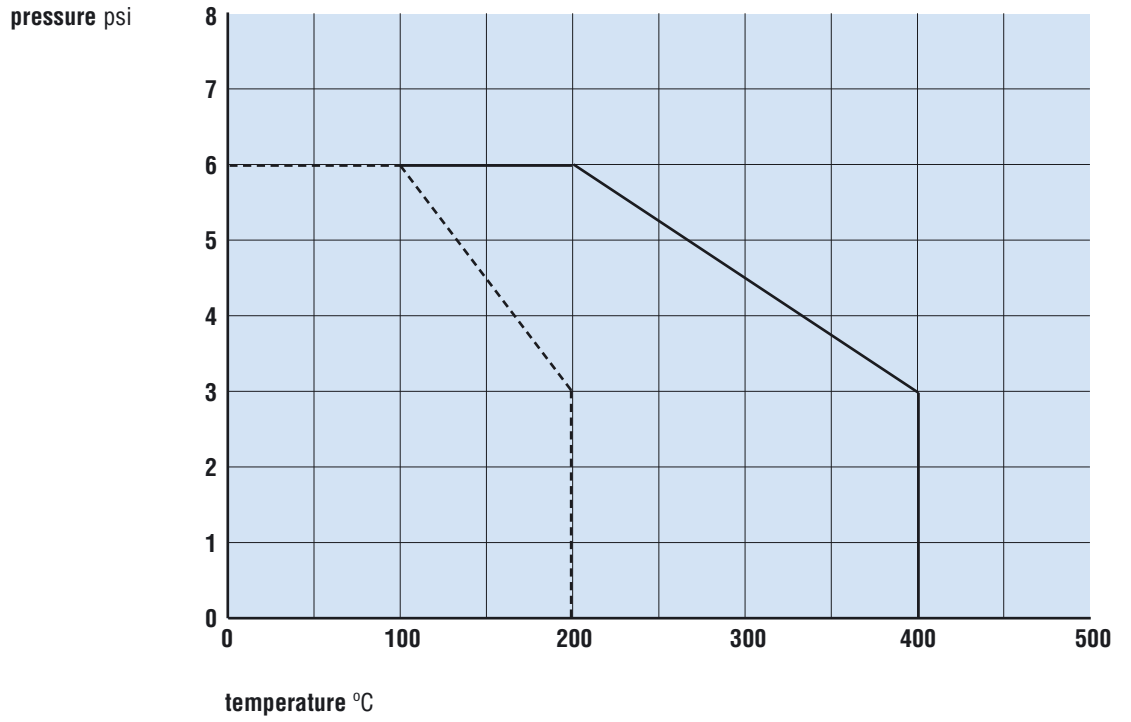

Valve turns vs CV

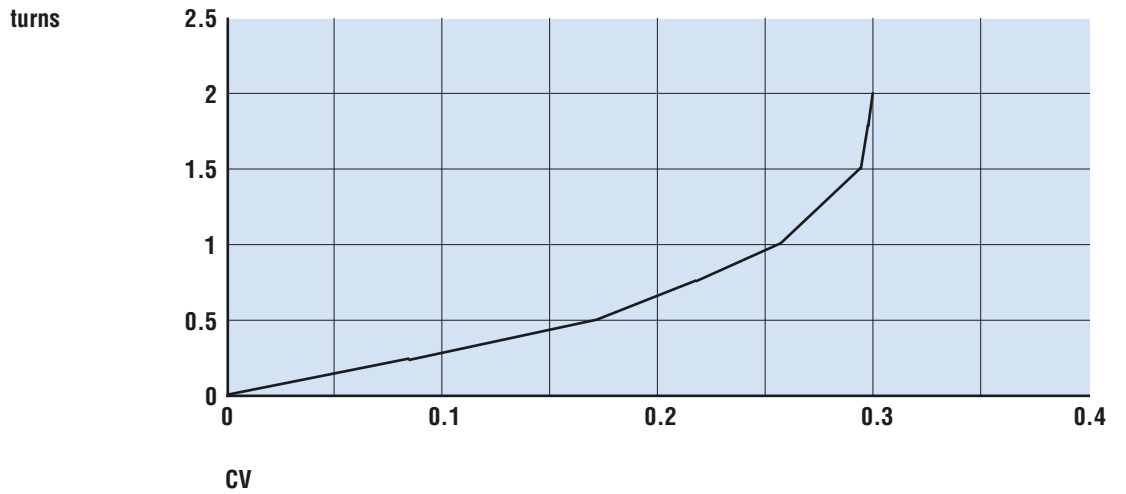

Female / Female Single Piece Body

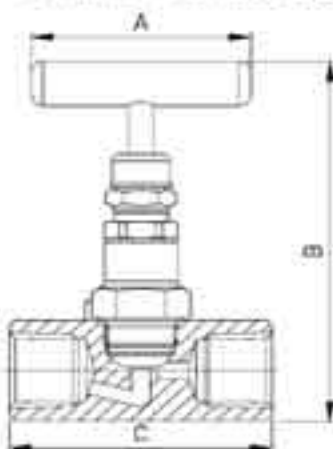

Thread	Part No	Dim A	Dim B	Dim C
1/4 NPT	NV2N	2.25	4.00	2.69
3/8 NPT	NV3N	2.25	4.00	2.69
1/2 NPT	NV4N	2.25	4.00	2.69

Male / Female Single Piece Body

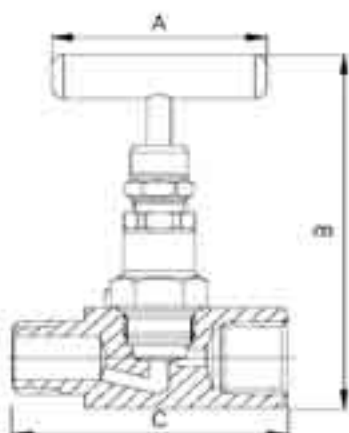

Thread	Part No	Dim A	Dim B	Dim C
1/4 NPT	NV2N M/F	2.25	4.00	2.88
3/8 NPT	NV3N M/F	2.25	4.00	2.88
1/2 NPT	NV4N M/F	2.25	4.00	2.88

Female / Female Single Piece Body with Bleed

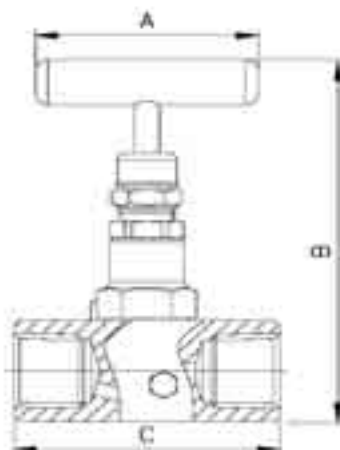

Thread	Part No	Dim A	Dim B	Dim C
1/4 NPT	NV2N-B	2.25	4.00	2.93
3/8 NPT	NV3N-B	2.25	4.00	2.93
1/2 NPT	NV4N-B	2.25	4.00	2.93

Female / Female Three Piece Body

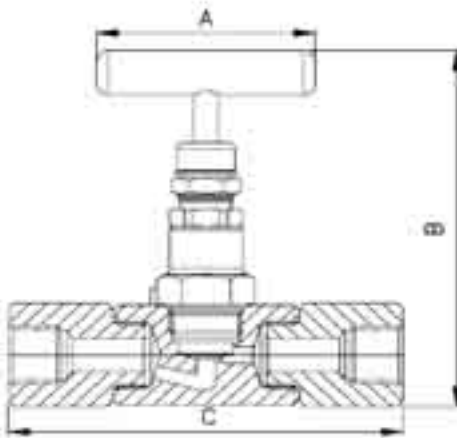

Thread	Part No	Dim A	Dim B	Dim C
1/4 NPT	NV2N-3	2.25	4.00	3.62
3/8 NPT	NV3N-3	2.25	4.00	4.05
1/2 NPT	NV4N-3	2.25	4.00	4.17
1/4 BSPT	NV2T-3	2.25	4.00	3.62
3/8 BSPT	NV3T-3	2.25	4.00	3.84
1/2 BSPT	NV4T-3	2.25	4.00	4.17
1/4 BSP	NV2P-3	2.25	4.00	3.50
3/8 BSP	NV3P-3	2.25	4.00	3.84
1/2 BSP	NV4P-3	2.25	4.00	4.12

Male / Female Three Piece Body

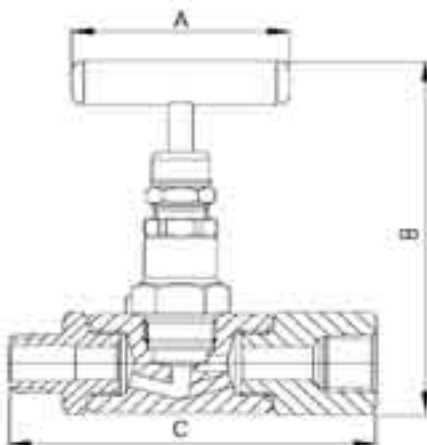

Thread	Part No	Dim A	Dim B	Dim C
1/4 NPT	NV2N-3-M/F	2.25	4.00	3.58
3/8 NPT	NV3N-3-M/F	2.25	4.00	3.80
1/2 NPT	NV4N-3-M/F	2.25	4.00	4.12
1/4 BSPT	NV2T-3-M/F	2.25	4.00	3.52
3/8 BSPT	NV3T-3-M/F	2.25	4.00	3.63
1/2 BSPT	NV4T-3-M/F	2.25	4.00	3.99
1/4 BSP	NV2P-3-M/F	2.25	4.00	3.36
3/8 BSP	NV3P-3-M/F	2.25	4.00	3.67
1/2 BSP	NV4P-3-M/F	2.25	4.00	3.87

Male / Male Three Piece Body

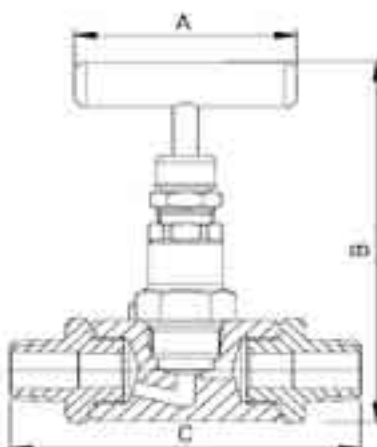

Thread	Part No	Dim A	Dim B	Dim C
1/4 NPT	NV2N-3-M/M	2.25	4.00	3.55
3/8 NPT	NV3N-3-M/M	2.25	4.00	3.55
1/2 NPT	NV4N-3-M/M	2.25	4.00	4.06
1/4 BSPT	NV2T-3-M/M	2.25	4.00	3.42
3/8 BSPT	NV3T-3-M/M	2.25	4.00	3.42
1/2 BSPT	NV4T-3-M/M	2.25	4.00	3.80
1/4 BSP	NV2P-3-M/M	2.25	4.00	3.22
3/8 BSP	NV3P-3-M/M	2.25	4.00	3.50
1/2 BSP	NV4P-3-M/M	2.25	4.00	3.62

Female / Female Three Piece Body with Bleed

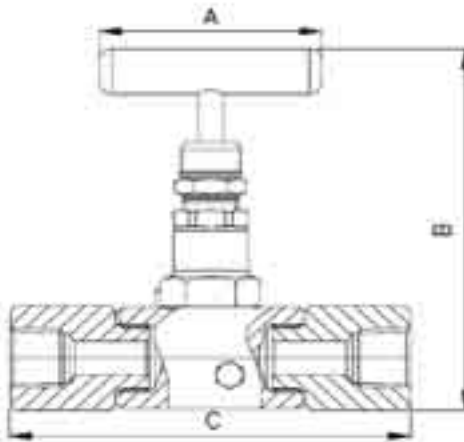

Thread	Part No	Dim A	Dim B	Dim C
1/4 NPT	NV2N-3-B	2.25	4.00	3.87
3/8 NPT	NV3N-3-B	2.25	4.00	4.30
1/2 NPT	NV4N-3-B	2.25	4.00	4.42
1/4 BSPT	NV2T-3-B	2.25	4.00	3.87
3/8 BSPT	NV3T-3-B	2.25	4.00	4.09
1/2 BSPT	NV4T-3-B	2.25	4.00	4.42
1/4 BSP	NV2P-3-B	2.25	4.00	3.75
3/8 BSP	NV3P-3-B	2.25	4.00	4.00
1/2 BSP	NV4P-3-B	2.25	4.00	4.37

Male / Female Three Piece Body with Bleed

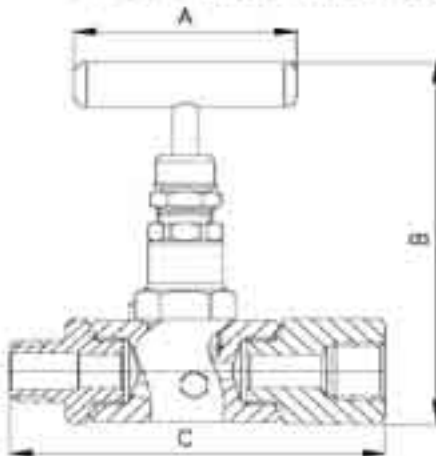

Thread	Part No	Dim A	Dim B	Dim C
1/4 NPT	NV2N-3-M/F-B	2.25	4.00	3.84
3/8 NPT	NV3N-3-M/F-B	2.25	4.00	4.05
1/2 NPT	NV4N-3-M/F-B	2.25	4.00	4.37
1/4 BSPT	NV2T-3-M/F-B	2.25	4.00	3.77
3/8 BSPT	NV3T-3-M/F-B	2.25	4.00	3.88
1/2 BSPT	NV4T-3-M/F-B	2.25	4.00	4.24
1/4 BSP	NV2P-3-M/F-B	2.25	4.00	3.61
3/8 BSP	NV3P-3-M/F-B	2.25	4.00	3.92
1/2 BSP	NV4P-3-M/F-B	2.25	4.00	4.12

Male / Male Three Piece Body with Bleed

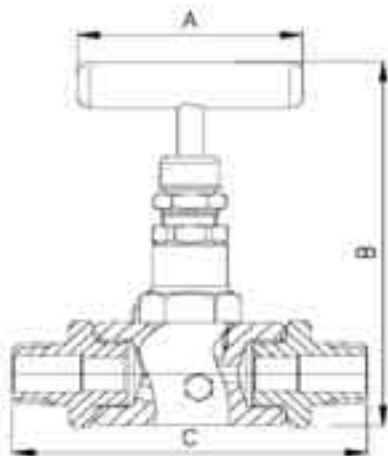

Thread	Part No	Dim A	Dim B	Dim C
1/4 NPT	NV2N-3-M/M-B	2.25	4.00	3.80
3/8 NPT	NV3N-3-M/M-B	2.25	4.00	3.86
1/2 NPT	NV4N-3-M/M-B	2.25	4.00	4.31
1/4 BSPT	NV2T-3-M/M-B	2.25	4.00	3.87
3/8 BSPT	NV3T-3-M/M-B	2.25	4.00	3.73
1/2 BSPT	NV4T-3-M/M-B	2.25	4.00	4.05
1/4 BSP	NV2P-3-M/M-B	2.25	4.00	3.47
3/8 BSP	NV3P-3-M/M-B	2.25	4.00	3.75
1/2 BSP	NV4P-3-M/M-B	2.25	4.00	3.87

Ringlok Compression End Single Piece Body

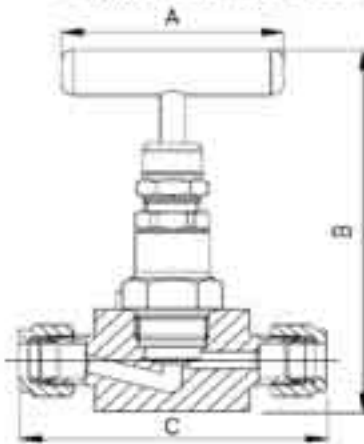

O/D Size	Part No	Dim A	Dim B	Dim C
6mm Ringlok	NV 6M=OD	2.25	4.00	2.99
8mm Ringlok	NV 8M=OD	2.25	4.00	3.06
10mm Ringlok	NV 10M=OD	2.25	4.00	3.12
12mm Ringlok	NV 12M=OD	2.25	4.00	3.32
1/4 Ringlok	NV2=OD	2.25	4.00	3.00
3/8 Ringlok	NV3=OD	2.25	4.00	3.12
1/2 Ringlok	NV4=OD	2.25	4.00	3.32
5/8 Ringlok	NV5=OD	2.25	4.00	3.32

Ringlok Compression End Three Piece Body

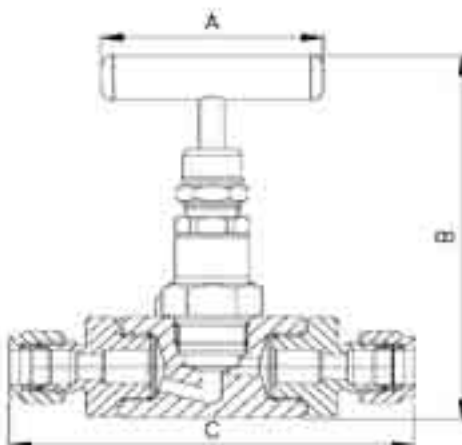

O/D Size	Part No	Dim A	Dim B	Dim C
6mm Ringlok	NV 6M=OD-3	2.25	4.00	3.98
8mm Ringlok	NV 8M=OD-3	2.25	4.00	4.04
10mm Ringlok	NV 10M=OD-3	2.25	4.00	4.10
12mm Ringlok	NV 12M=OD-3	2.25	4.00	4.30
1/4 Ringlok	NV2=OD-3	2.25	4.00	3.99
3/8 Ringlok	NV3=OD-3	2.25	4.00	4.10
1/2 Ringlok	NV4=OD-3	2.25	4.00	4.30
5/8 Ringlok	NV5=OD-3	2.25	4.00	4.30

Ringlok Compression End Three Piece Body with Bleed

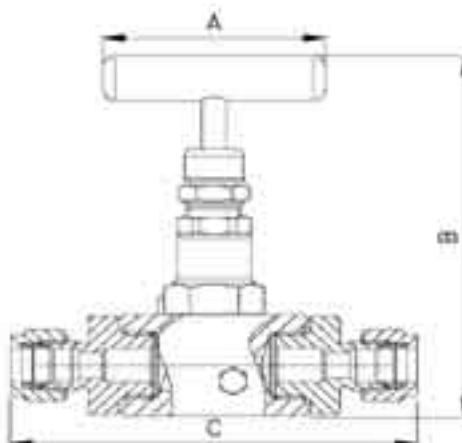

O/D Size	Part No	Dim A	Dim B	Dim C
6mm Ringlok	NV 6M=OD-3-B	2.25	4.00	4.23
8mm Ringlok	NV 8M=OD-3-B	2.25	4.00	4.29
10mm Ringlok	NV 10M=OD-3-B	2.25	4.00	4.35
12mm Ringlok	NV 12M=OD-3-B	2.25	4.00	4.55
1/4 Ringlok	NV2=OD-3-B	2.25	4.00	4.24
3/8 Ringlok	NV3=OD-3-B	2.25	4.00	4.35
1/2 Ringlok	NV4=OD-3-B	2.25	4.00	4.55
5/8 Ringlok	NV5=OD-3-B	2.25	4.00	4.55

Duoloc Compression End Three Piece Body

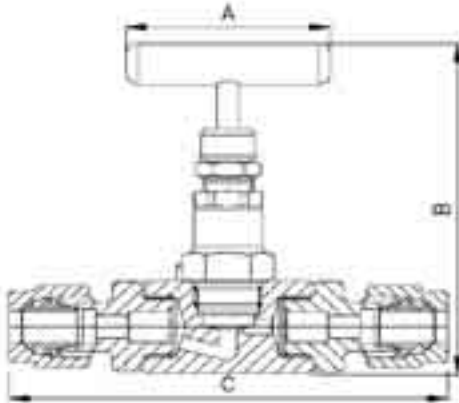

O/D Size	Part No	Dim A	Dim B	Dim C
6mm Duoloc	NV 6M OD-3	2.25	4.00	3.96
8mm Duoloc	NV 8M OD-3	2.25	4.00	4.02
10mm Duoloc	NV 10M OD-3	2.25	4.00	4.00
12mm Duoloc	NV 12M OD-3	2.25	4.00	4.10
1/4 Duoloc	NV2 OD-3	2.25	4.00	3.97
3/8 Duoloc	NV3 OD-3	2.25	4.00	4.00
1/2 Duoloc	NV4 OD-3	2.25	4.00	4.10

Duoloc Compression End Three Piece Body with Bleed

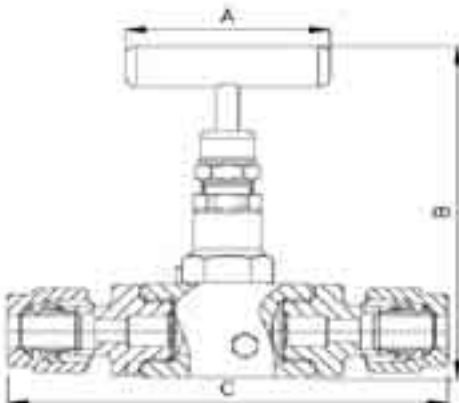

O/D Size	Part No	Dim A	Dim B	Dim C
6mm Duoloc	NV 6M OD-3-B	2.25	4.00	4.21
8mm Duoloc	NV 8M OD-3-B	2.25	4.00	4.27
10mm Duoloc	NV 10M OD-3-B	2.25	4.00	4.25
12mm Duoloc	NV 12M OD-3-B	2.25	4.00	4.35
1/4 Duoloc	NV2 OD-3-B	2.25	4.00	4.22
3/8 Duoloc	NV3 OD-3-B	2.25	4.00	4.25
1/2 Duoloc	NV4 OD-3-B	2.25	4.00	4.35

Combination of Ends Three Piece Body with and without Bleed

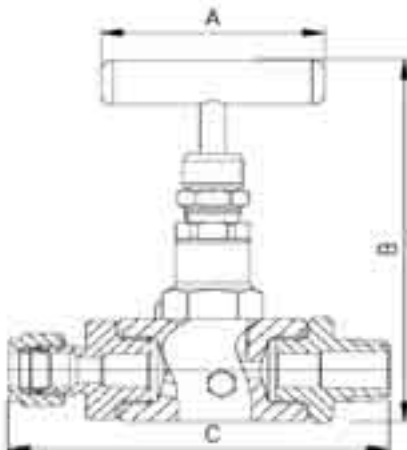

For example:

3/8" OD Ringlok twin ferrule
compression end

To

1/4" NPT male end

Ask for details about any combination

The Waverley brownall Manifold range is produced to the highest standards in line with BS EN ISO 9001 requisites. They are designed to provide reliability under demanding conditions, repeatedly giving bubble tight shut off.

2 Way Manifold

Available in direct or remote mount formats, the 2 way manifold combines an isolation valve with a vent valve in one compact unit. Connections are available in a variety of sizes and thread forms including NPT, BSPT & BSPP.

Designed to combine isolation, calibration or test with venting of instruments in one compact assembly. The applications for the manifold include pressure gauges, transmitters and switches.



3 Way Manifold

Also available in direct or remote mount formats, the 3 way manifold combines two isolation valves with an equalise valve, and where required, a bleed valve in one compact unit.

Used with differential pressure transmitters, these manifolds combine instrument isolation with equalising in one compact assembly.

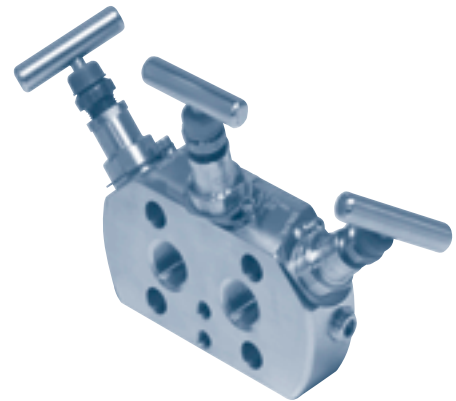

5 Way Manifold

Also available in direct or remote mount format the 5 way manifold combines two isolation valves with an equalise valve, and two vent valves in one compact unit.

Used with differential pressure transmitters, these manifolds combine instrumentation isolation with equalising and vent function in one compact assembly.

Again, the process instrument and vent connections for both 3 and 5 way valves can be provided in a variety of sizes and thread forms including NPT, BSPT & BSPP.

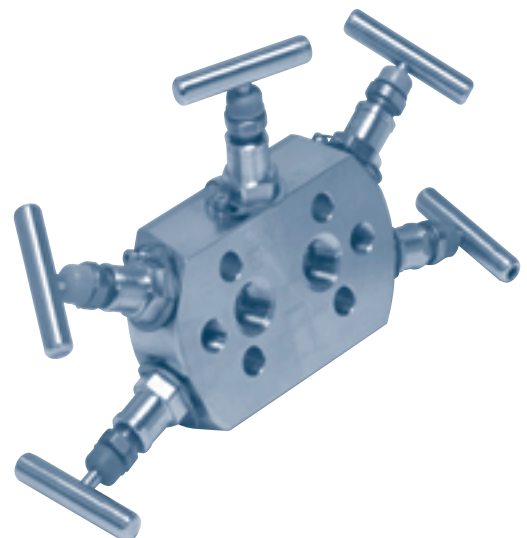

Manifold Valves Ordering Data

For Example - Part No. – WMS5D-P- 5-15-NF-1-S

5 Valve Direct Manifold rated at 6000psi, with 1/2"NPT[F], with 1/4 NPT vent, in 316 St St, with anti-tamper heads.

WMS 5 D P 5 15 NF 1 S AT

Valve Type

WMS Waverley
Manifold Series

Number of valves

2 Valve
3 Valve
5 Valve

Valve Mounting

Direct or Remote

Pressure Rating

P - 6,000 psi
X - 10,000 psi

Orifice Size

5mm

Inlet Size

08 - 1/2"
15 - 3/4"

Inlet Thread

NF - NPT Female
PF - BSPP Female
TF - BSPT Female

Vent size

0 - No Vent, 2 - 1/4 BSPP
1 - 1/4 NPT, 3 - 1/2 NPT
4 - 1/2 BSPP

Options

AT - Anti Tamper
ATK - Anti Tamper Key
G - Graphoil
HW - Handwheel
Tg - Tagging
Tf - Soft Tip (PEEK)
Tk - Soft Tip (PTFE)
TM - Metering Tip

Material

A - All Bronze
C - Carbon Steel
D - Duplex
H - Hastelloy
I - Incoloy
M - Monel
S - 316 St St
X - Special

Part Number WMS2I

A 2 Valve Inline Needle type for Isolation, and Venting

6,000 psi [Pn 408] Rated and 10,000 psi [Pn 680] Rated

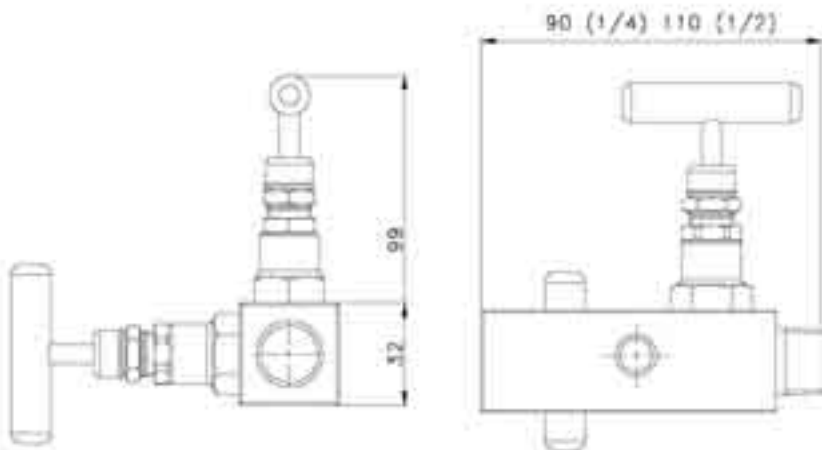
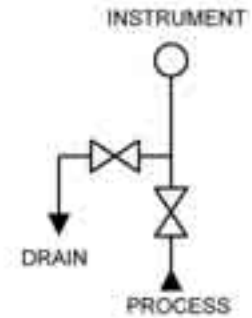

Part Number WMS2D

A 2 Valve Direct Mounting Manifold for Isolation and Calibration and an angled Vent head for ease of use

6,000 psi [Pn 408] Rated and 10,000 psi [Pn 680] Rated

Weight 1.25 Kg

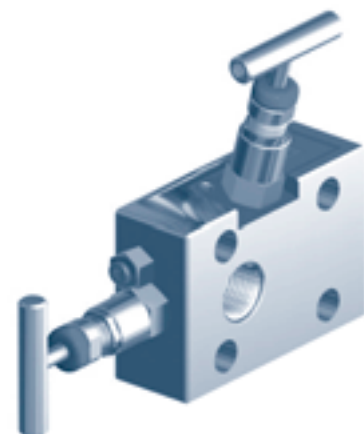
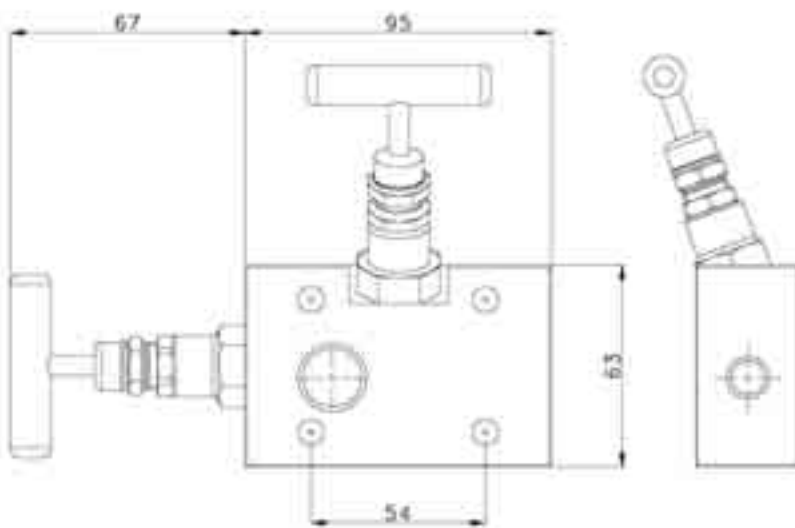
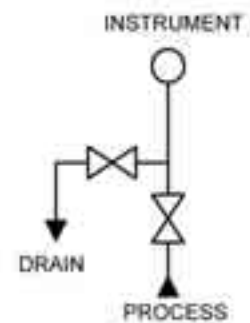

Part Number WMS2R

A 2 Valve Remote Manifold for Isolation and Calibration and an angled vent head, for use in wall mounting applications.

6,000 psi [Pn 408] Rated and 10,000 psi [Pn 680] Rated. Weight 0.9Kg

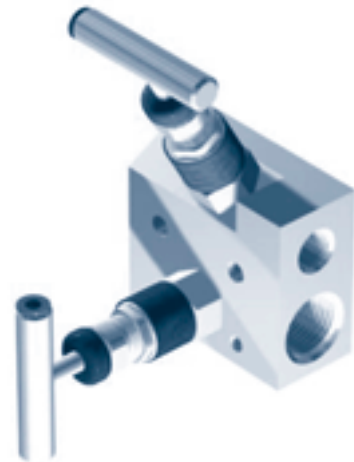
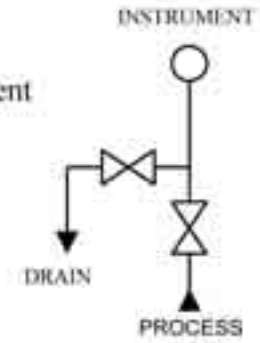
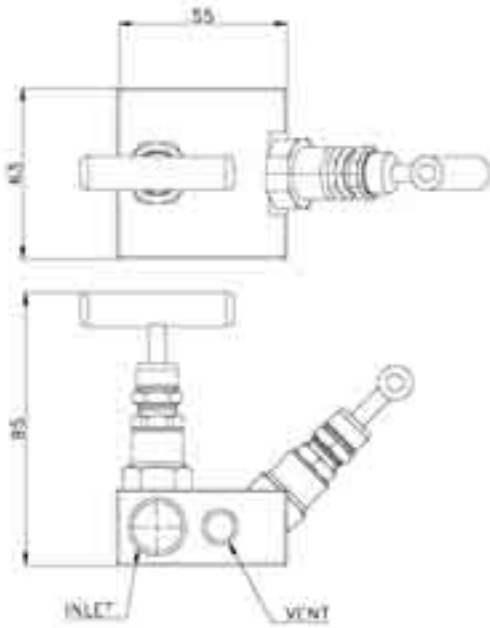

Part Number WMS3R

A 3 Valve Remote Manifold for Isolation and Equalization.

6,000 psi [Pn 408] Rated and 10,000 psi [Pn 680] Rated. Weight 1.45 Kg

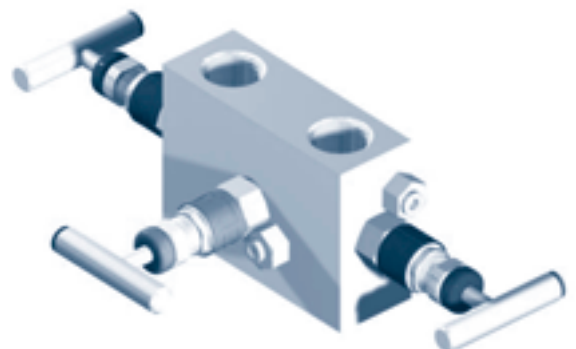
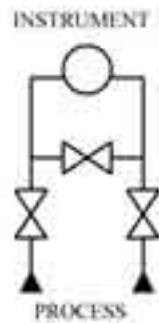
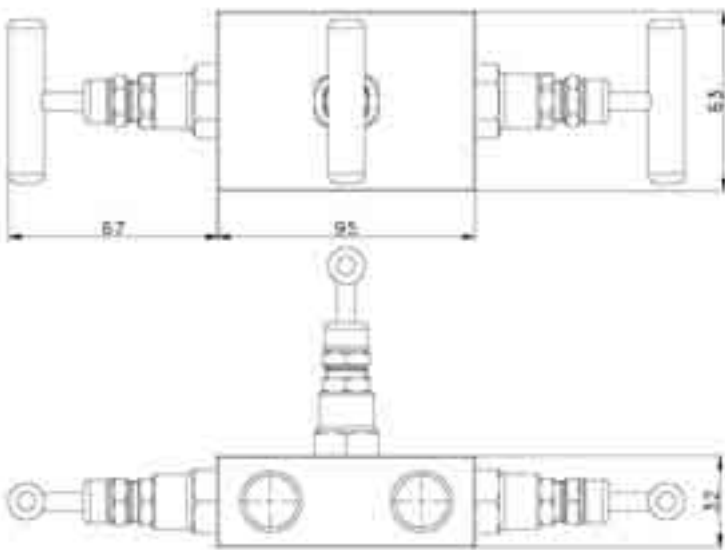

Part Number WMS3D

A Compact bodied 3 Valve Direct Manifold for Isolation and an angled Equalization head for ease of use

6,000 psi [Pn 408] Rated and 10,000 psi [Pn 680] Rated. Weight 1.45 Kg

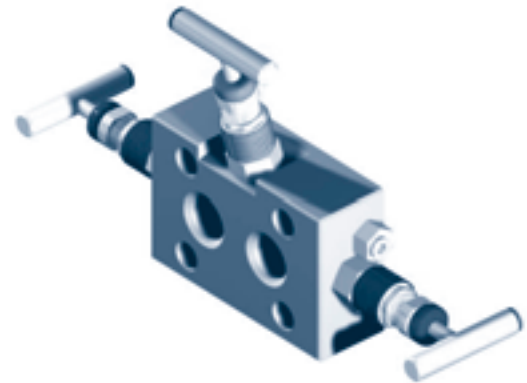
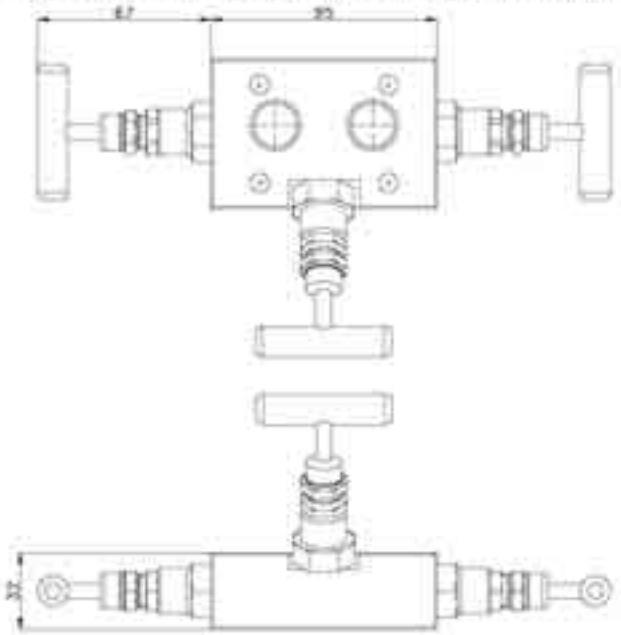

INSTRUMENT

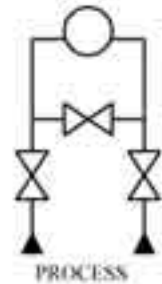

Part Number WMS5R

A 5 Valve Remote Manifold for Isolation and Equalization and Venting

6,000 psi [Pn 408] Rated and 10,000 psi [Pn 680] Rated. Weight 1.95Kg

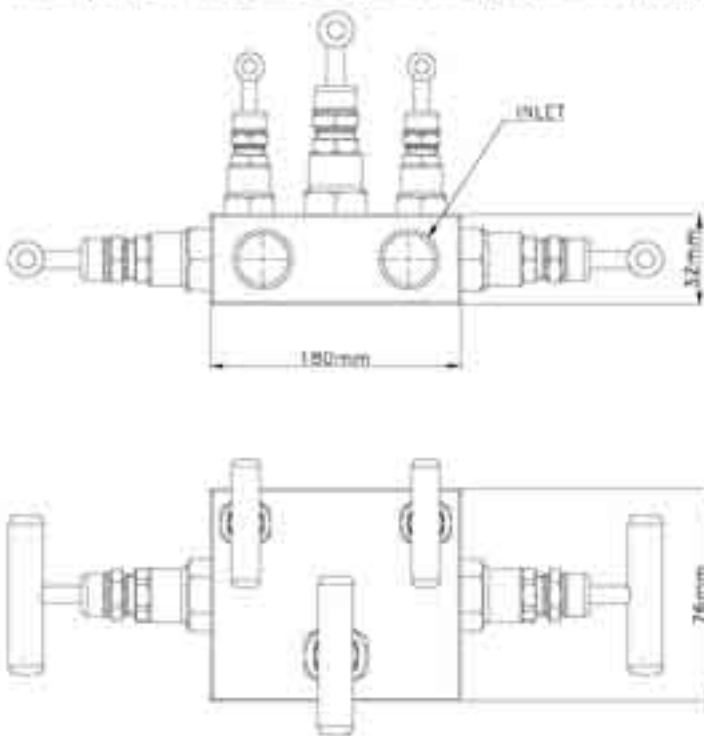

INSTRUMENT

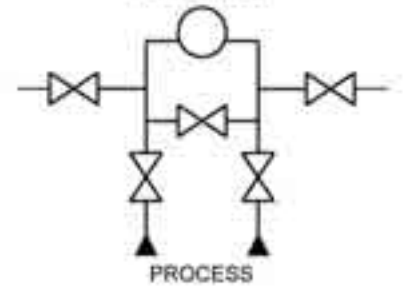

Part Number WMS5D

A 5 Valve Direct Mounting Manifold for Isolation, Equalization and Venting

6,000 psi [Pn 408] Rated and 10,000 psi [Pn 680] Rated. Weight 3.05 Kg

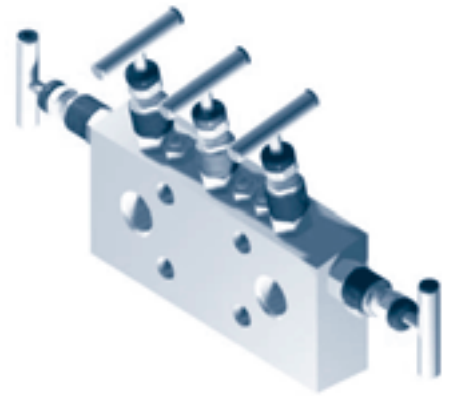
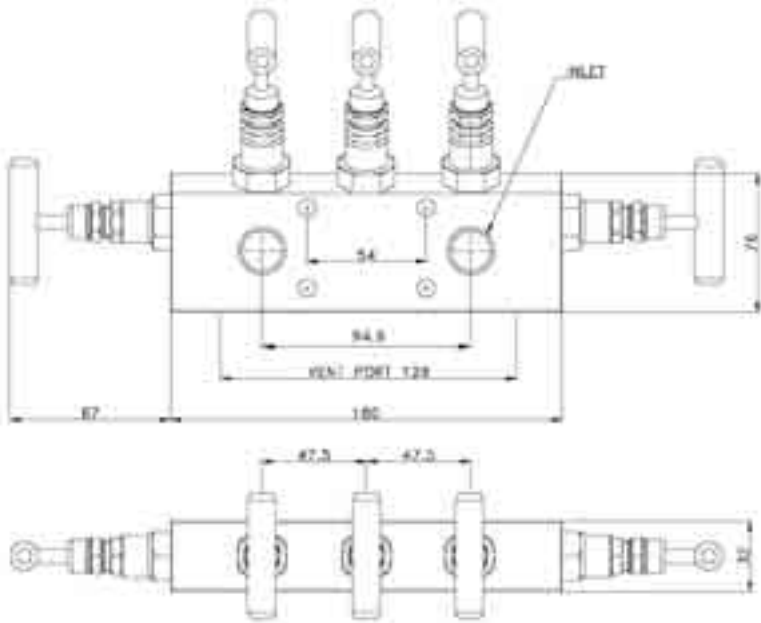
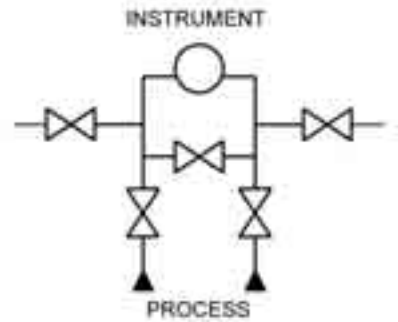

The Waverley brownall Monoflange Manifold Valves are designed to replace multi valve assemblies with one compact manifold. These primary block valves have the advantage of offering all process instrumentation double block and bleed valves in one unit. This reduces the potential leak points, reduces weight and space, cuts down installation time and reduces maintenance. All this from a manifold which will cost you less than the multi valve assembly it replaces.

They are constructed from 316 bar stock and high quality 316 stainless steel forgings.

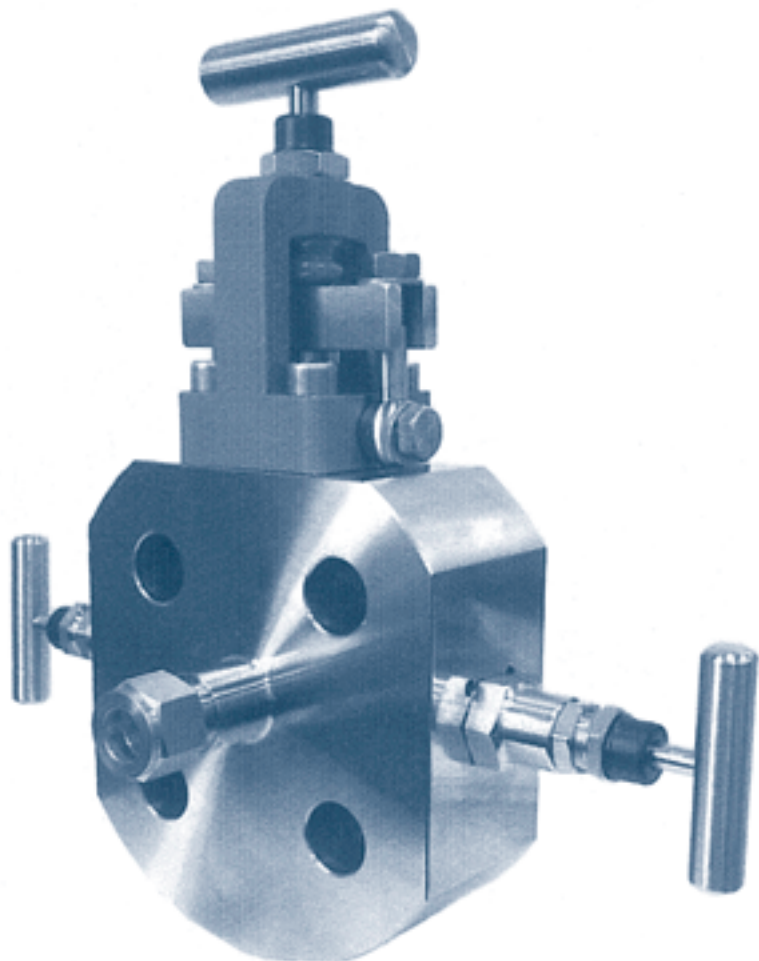

Typical Construction

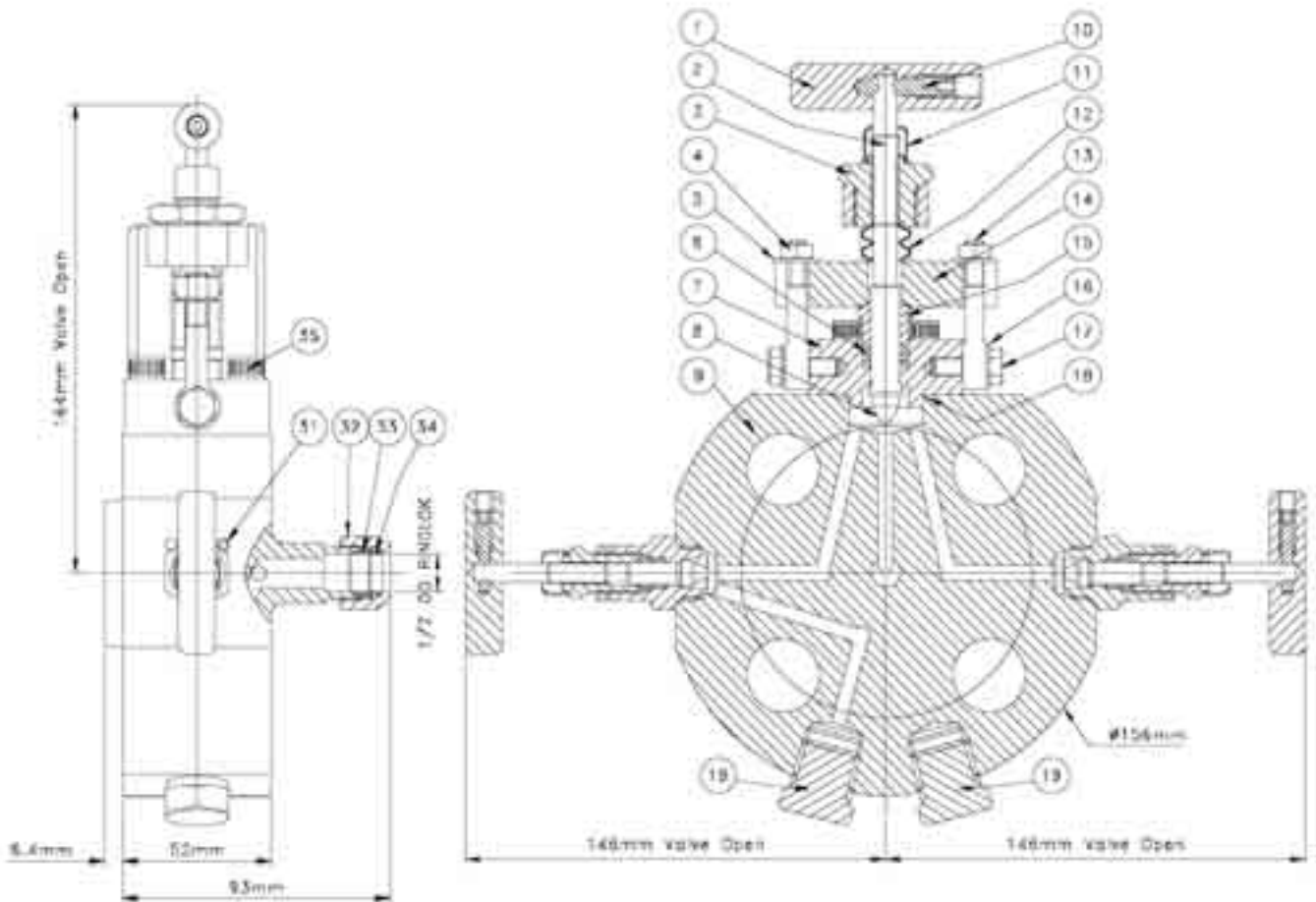

Description	Material
1 Handle	316 Stainless Steel
2 Stem	ASTM A182 Gr F216
3 Body Nut	316 Stainless Steel
4 Nut	A2 Stainless Steel
5 Washer	316 Stainless Steel
6 Packing	Graphite
7 OS&Y body	316 Stainless Steel
8 Non-rotating tip	17-4-PH
9 Body	ASTM A182 Gr F216
10 Handle screw	A2 Stainless Steel
11 Dust Cap	PVC
12 Dust Bellows	PVC
13 Bolt	A2 Stainless Steel
14 Yoke	316 Stainless Steel
15 Gland	316 Stainless Steel
16 Washer	316 Stainless Steel
17 Bolt	A2 Stainless Steel

Description	Material
18 Body Seal	Graphite
19 1/2 NPT Plug	316 Stainless Steel
20 Handle	316 Stainless Steel
21 Stem	316 Stainless Steel
22 Gland Packer	316 Stainless Steel
23 Gland	316 Stainless Steel
24 Bonnet	316 Stainless Steel
25 Handle Screw	A2 Stainless Steel
26 Dust Cap	PVC
27 Locknut	316 Stainless Steel
28 Packing	Graphite
29 Non-rotating tip	17-4-PH
30 Body Seal	Graphite
31 Locking pin	316 Stainless Steel
32 Nut	316 Stainless Steel
33 Back Ferrule	316 Stainless Steel
34 Front Ferrule	316 Stainless Steel
35 Bolt	ASTM A 193

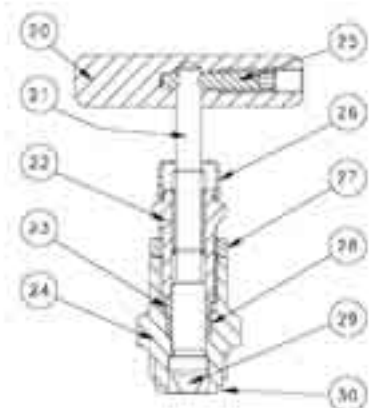

Specifically designed for low pressure air utilising the Waverley brownall Ball Valve range. The manifold body is manufactured from extruded section in 316 stainless steel.

The Airheader manifold offers multiple outlets from a common inlet. Compact, reliable pressure certified from full material traceability of all elements gives the user assurance of safety with durability. A drain cock at the bottom of the device completes the package whilst 4 x M8 mounting holes on the rear provides easy installation.

A typical example of an 8 way 316 stainless steel airheader

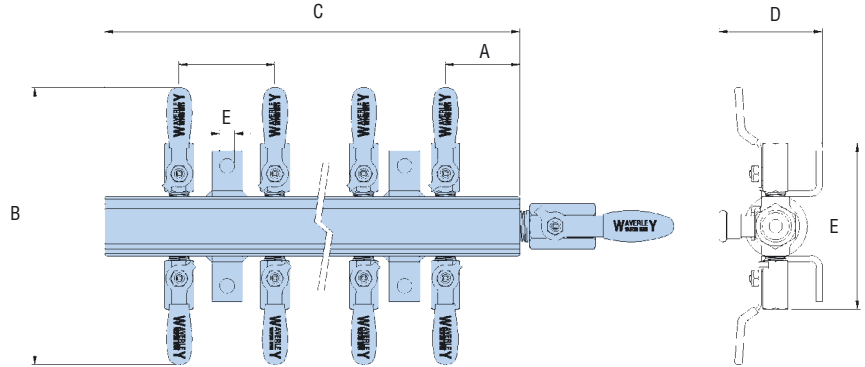

Dimensions

A	51mm
B	188mm
C	*
D	70mm
E	113mm
F	75mm

*C is dependant on number of valves

6 way	232mm
12 way	427mm
16 way	557mm

Flange adaptor kidney type

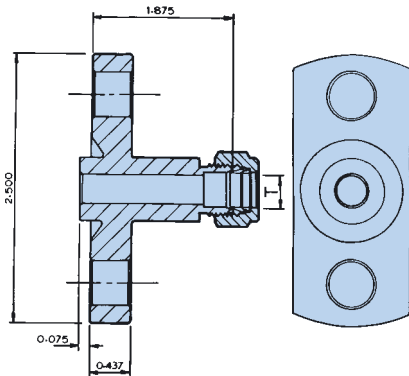

drawing	description
F6511	Ringlok® connection grooved face flange
F6512	Ringlok® connection flat face flange
F6513	Duoloc® connection grooved face flange
F6514	Duoloc® connection flat face flange

Above drawing numbers and diagram are for a typical flange configuration for up to 100 bar pressure.

The Waverley brownall flange adaptor is available in several conditions.

The flange connection may be grooved for insertion of sealing washer, or in the flat face condition.

Both of the above conditions may be combined with either single or twin ferrule ends, weld and screwed connections.

Available in 316 and 316L material.

T – tube OD is available in metric and imperial compression ends up to 12mm OD and 1/2" OD single or twin ferrule design.

Overall length of component (including nut) will vary slightly with size and type of compression end.

Important

Compression joints to be assembled in a pre-assembly tool before being re-assembled into flange.

Flange detail can be supplied in accordance with DIN 19 213 up to a maximum working pressure of 400 bar.

Ordering example

Example for 1/2" OD Duoloc® flange adaptor with groove face

F6513 G-4-D

drawing number

face finish

G grooved
F flat

OD size

2 1/4"
3 3/8"
4 1/2"
M6 6mm
M8 8mm
M10 10mm
M12 12mm

Duoloc® or Ringlok®

D Duoloc®
R Ringlok®

larger OD sizes are available

The Waverley brownall range of stainless steel check valves is one of the most comprehensive in the World.

Our standard valve is the CV series which is designed to give unidirectional flow control of liquids and gases with a minimal pressure drop. It is a general purpose poppet type check valve for flow control up to pressures of 3000 psi. The CV series is available in a wide range of inlet and outlet port connections from 1/4" to 1 1/2".

The Waverley brownall mini valve is the MCV and ACV series which are miniature, compact one piece body check valves for unidirectional control of flow up to pressures of 6000 psi. The MCV is our standard pre-set Mini valve while the ACV series valve comes with an adjustable spring to give a variable cracking pressure.



Benefits, applications and design features

Features

- Robust design
- Poppet mounted seal
- Choice of PTFE or Viton seals
- Variety of cracking pressures
- Minimal pressure drop
- Bubble tight shut off

Applications

- Prevents reverse flow
- Low pressure relief valve
- Locks upstream pressure
- Up to 3,000psi
- Liquid or vapour service

Benefit

Body precision machined from 316 Stainless Steel incorporating male female threaded connections, Duoloc® and Ringlok® compression ends.

Poppet machined from 316 stainless steel incorporating PTFE or Viton seal.

Choice of springs for a range of preset cracking pressures.

Endcap manufactured from 316 stainless steel, with precision machined cone for bubble tight shut off (PTFE or Viton seal).

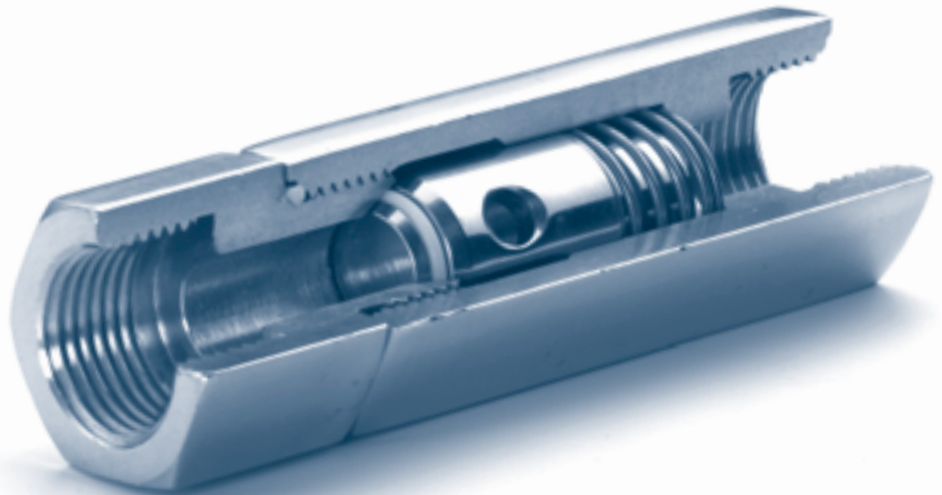

Technical specifications

Technical specifications

Pressure range	0-3000psi
Temperature range PTFE	-45 to 230°C
Temperature range Viton	-23 to 200°C
Nominal cracking pressure	5,15,25,30,45psi
Others on request	
CV rating valve size	CV
1/4"	0.65
3/8"	0.65
1/2"	1.92
3/4"	6.10
1"	6.60

Materials of construction

Body	316 stainless steel
Spring	316 stainless steel
Poppet	316 stainless steel
O-Ring	PTFE/Viton
End cap	316 stainless steel
Body seal	PTFE/Viton

Valve connections

NPT	ANSI/ASME B1-20.1
BSPT	BS21
BSP	BS2779

Valve markings

Make or manufacturer	Waverley
Direction arrow	
Pressure rating	3000 psi
Cast code	ABC

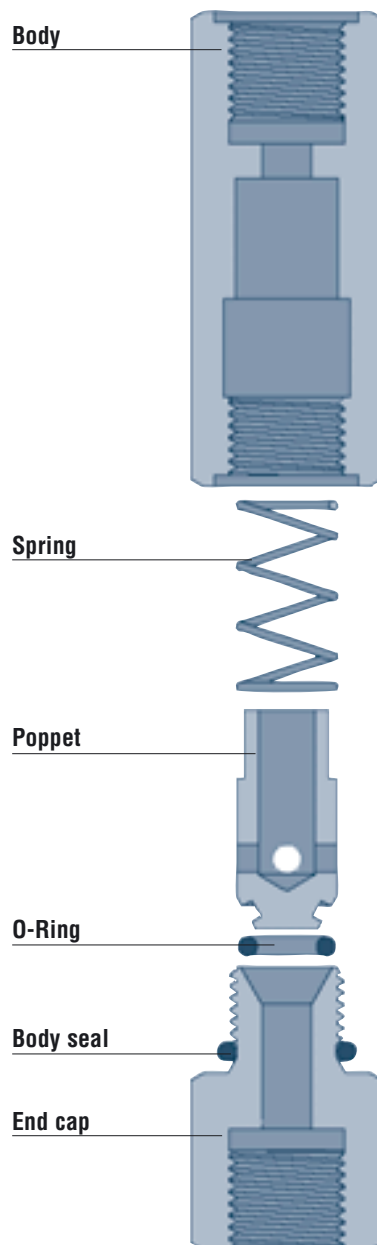

Testing

Waverley check valves have been tested for sealing performance based on BS 6755 Pt1. These tests consist of: Low pressure (50psi 3.5 bar) High pressure shell (4,500psi 310 Bar)

Seal kits

Seal kits are supplied for necessary maintenance. These consist of poppet and end-cap seals and a new spring.

Cleaning and packaging

All check valves are dispatched fully degreased and sealed. Cleaning for oxygen use on application.

Air flow

- 1/4", 3/8"
- 1/2"
- 3/4", 1"

pressure drop psi

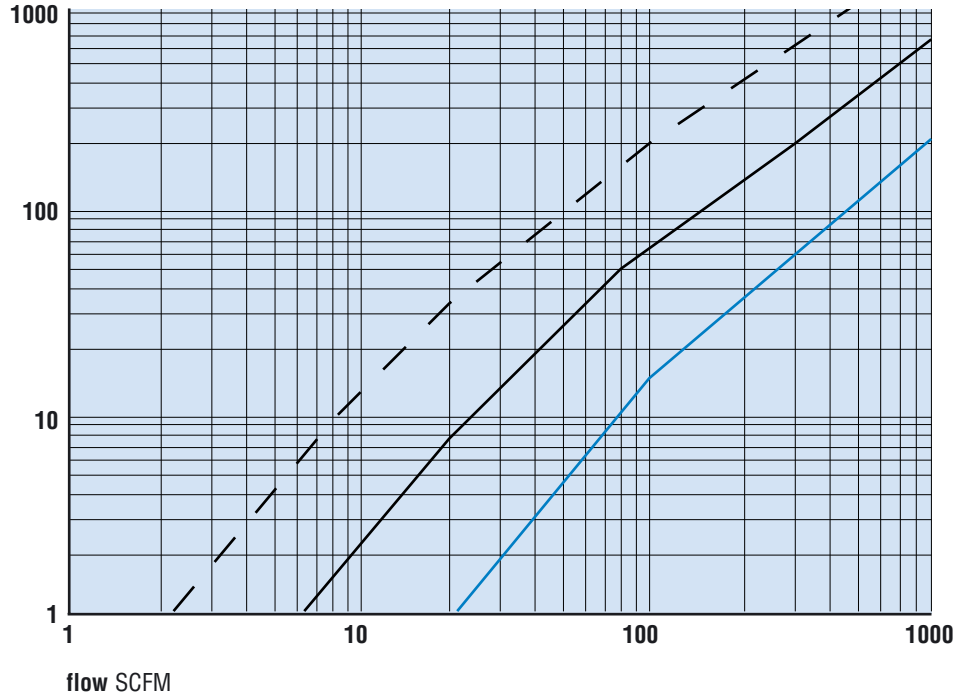

Water flow

- 1/4", 3/8"
- 1/2"
- 3/4", 1"

flow GPM

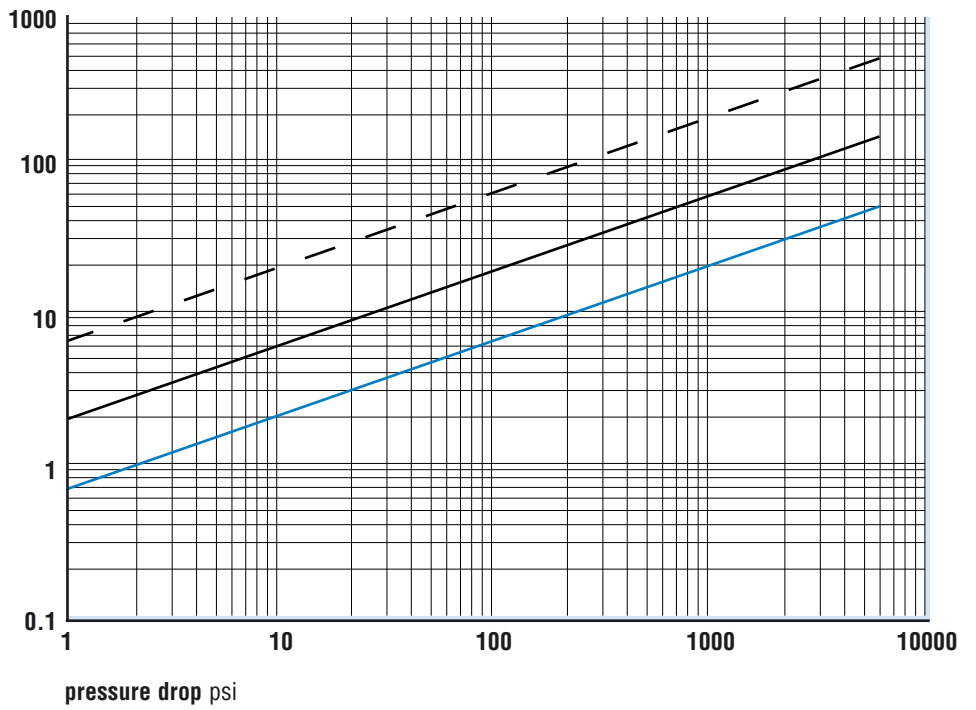

Female/female

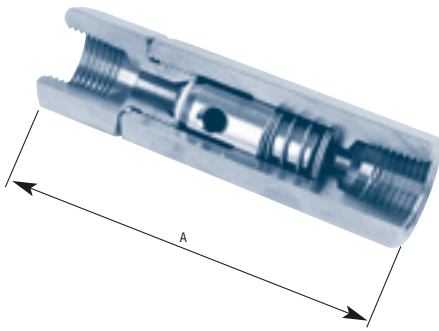

thread size	part number	A	hex A/F
1/8" BSP	CV1P	3.000"	0.750"
1/4" BSP	CV2P	3.000"	0.750"
3/8" BSP	CV3P	3.500"	0.875"
1/2" BSP	CV4P	4.000"	1.125"
3/4" BSP	CV6P	5.800"	1.670"
1" BSP	CV8P	5.800"	1.670"
1 1/2" BSP	CV12P	6.565"	2.500"
1/4" BSPT	CV2T	3.000"	0.750"
3/8" BSPT	CV3T	3.500"	0.875"
1/2" BSPT	CV4T	4.000"	1.125"
3/4" BSPT	CV6T	5.800"	1.670"
1" BSPT	CV8T	5.800"	1.670"
1 1/2" BSPT	CV12T	7.100"	2.500"
1/4" NPTF	CV2N	3.000"	0.750"
3/8" NPTF	CV3N	3.500"	0.875"
1/2" NPTF	CV4N	4.000"	1.125"
3/4" NPTF	CV6N	5.800"	1.670"
1" NPTF	CV8N	5.800"	1.670"
1 1/2" NPTF	CV12N	7.100"	2.500"

Male/female



thread size	part number	B	hex A/F
1/8" BSP	CV1P M/F	2.825"	0.750"
1/4" BSP	CV2P M/F	2.825"	0.750"
3/8" BSP	CV3P M/F	3.355"	0.875"
1/2" BSP	CV4P M/F	4.000"	1.125"
3/4" BSP	CV6P M/F	5.670"	1.670"
1" BSP	CV8P M/F	5.720"	1.670"
1/4" BSPT	CV2T M/F	2.875"	0.750"
3/8" BSPT	CV3T M/F	3.375"	0.875"
1/2" BSPT	CV4T M/F	4.100"	1.125"
3/4" BSPT	CV6T M/F	5.670"	1.670"
1" BSPT	CV8T M/F	5.800"	1.670"
1/4" NPTF	CV2N M/F	2.875"	0.750"
3/8" NPTF	CV3N M/F	3.375"	0.875"
1/2" NPTF	CV4N M/F	4.100"	1.125"
3/4" NPTF	CV6N M/F	5.670"	1.670"
1" NPTF	CV8N M/F	5.800"	1.670"

Male/male

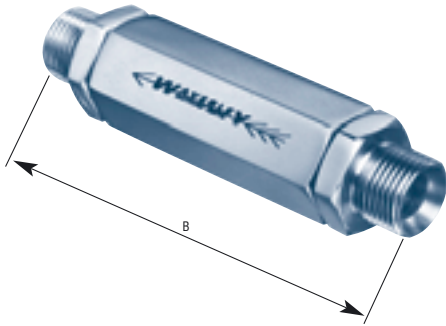

thread size	part number	B	hex A/F
1/8" BSP	CV1P M/M	3.395"	0.750"
1/4" BSP	CV2P M/M	3.525"	0.750"
3/8" BSP	CV3P M/M	4.135"	0.875"
1/2" BSP	CV4P M/M	5.000"	1.125"
3/4" BSP	CV6P M/M	6.795"	1.670"
1" BSP	CV8P M/M	6.895"	1.670"
1/4" BSPT	CV2T M/M	3.625"	0.750"
3/8" BSPT	CV3T M/M	4.187"	0.875"
1/2" BSPT	CV4T M/M	5.100"	1.125"
3/4" BSPT	CV6T M/M	6.795"	1.670"
1" BSPT	CV8T M/M	7.050"	1.670"
1/4" NPT	CV2N M/M	3.625"	0.750"
3/8" NPT	CV3N M/M	4.187"	0.875"
1/2" NPT	CV4N M/M	5.100"	1.125"
3/4" NPT	CV6N M/M	6.795"	1.670"
1" NPT	CV8N M/M	7.050"	1.670"

Duoloc® single ferrule OD compression

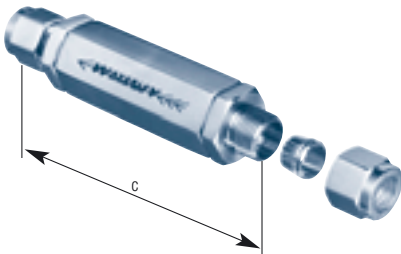

tube OD	part number	C	hex A/F
1/8"	CV1 OD	2.865"	0.750"
3/16"	CV3/16 OD	2.865"	0.750"
1/4"	CV2 OD	2.865"	0.750"
3/8"	CV3 OD	3.429"	0.875"
1/2"	CV4 OD	4.022"	1.125"
3/4"	CV6 OD	5.636"	1.670"
1"	CV8 OD	5.740"	1.670"
6mm	CV6M OD	75.5mm	19.0mm
8mm	CV8M OD	84.0mm	22.0mm
10mm	CV10M OD	88.0mm	28.5mm
12mm	CV12M OD	100.0mm	28.5mm
15mm	CV15M OD	103.0mm	28.5mm
16mm	CV16M OD	101.0mm	28.5mm
18mm	CV18M OD	106.0mm	28.5mm
20mm	CV20M OD	145.0mm	42.0mm
22mm	CV22M OD	145.0mm	42.0mm
25mm	CV25M OD	145.0mm	42.0mm

Ringlok® double ferrule OD compression

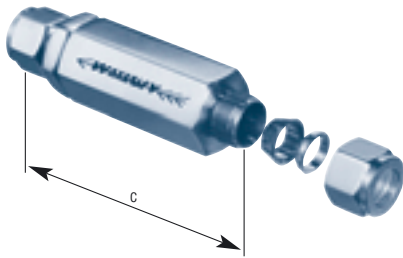

tube OD	part number	C	hex A/F
1/8"	CV1=OD	2.825"	0.750"
3/16"	CV3/16=OD	2.825"	0.750"
1/4"	CV2=OD	2.829"	0.750"
3/8"	CV3=OD	3.327"	0.875"
1/2"	CV4=OD	3.676"	1.125"
3/4"	CV6=OD	5.100"	1.670"
1"	CV8=OD	4.920"	1.670"
6mm	CV6M=OD	71.0mm	19.0mm
8mm	CV8M=OD	85.0mm	22.0mm
10mm	CV10M=OD	85.0mm	28.5mm
12mm	CV12M=OD	93.0mm	28.5mm
15mm	CV15M=OD	91.0mm	28.5mm
16mm	CV16M=OD	91.0mm	28.5mm
18mm	CV18M=OD	94.0mm	28.5mm
20mm	CV20M=OD	128.5mm	42.0mm
22mm	CV22M=OD	128.5mm	42.0mm
25mm	CV25M=OD	127.0mm	42.0mm

Replacement seal kits comprising of two seals and spring

valve size	part number
1/4"	CV2 SEALS
3/8"	CV3 SEALS
1/2"	CV4 SEALS
3/4"	CV6 SEALS
1"	CV8 SEALS

Benefits, applications and design features

Features

Working pressure up to 6,000psi
Fully encapsulated seal
Choice of Viton or Buna N seal
Variety of cracking pressures from 2 to 350psi
Minimal pressure drop
Bubble tight shut off

Design Features

Fully contained O-ring seal
One piece precision machined body
Adjustable spring
Lock screw to maintain crack pressure

Applications

Prevents reverse flow
Low pressure relief valve
Locks upstream pressure
Up to 6,000psi
Liquid or vapour service
Low pressure relief valve

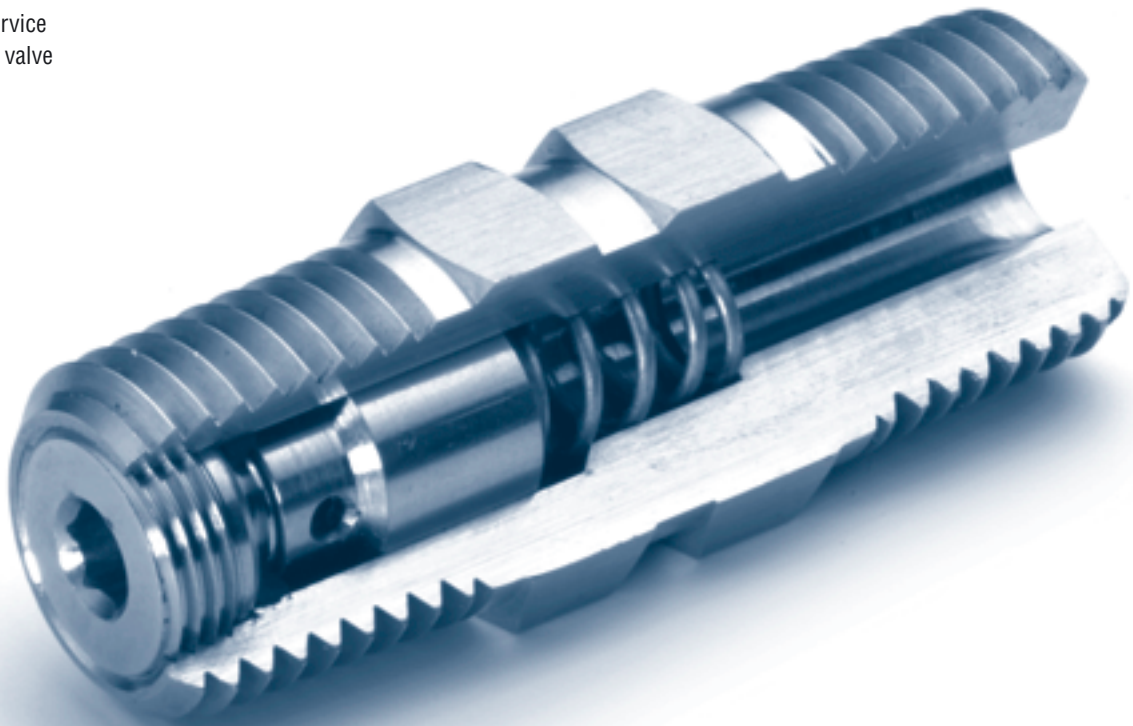

Technical specifications

Technical specifications

Pressure range	0-6000psi
Temperature range Viton	-23 to 200°C
Temperature range High Nitrile	-40 to 120°C
Factor of safety.	4:1
Nominal cracking pressure	3, 5, 10, 20, 40, 60, 100, 150 psi
CV rating Also see flow graphs	
1/4"	0.30
1/2"	0.92

Materials of construction

Part	Description	Material
A	Body	316 stainless steel
B	Spring	316 stainless steel
C	Poppet	316 stainless steel
D	O-Ring	Viton (Std)
E	Seal retainer	316 stainless steel
F	Lock screw	316 stainless steel
G	Adjusting screw	316 stainless steel

Valve connections

NPT	ANSI/ASME B1-20.1
BSPT	BS21
BSP	BS2779

Valve markings

Make or manufacturer	Waverley
Operating limits	6000psi
Direction arrow	
Cast code	ABC

Deflector cap

Part Number	Description	Material
2 VVC	1/4" Deflector	Nylon 6
2 VVC	1/2" Deflector	Nylon 6

Ordering

Thread Size	Part No
1/4" NPT	2N MCV
1/2" NPT	4N MCV
1/4" NPT	2N ACV

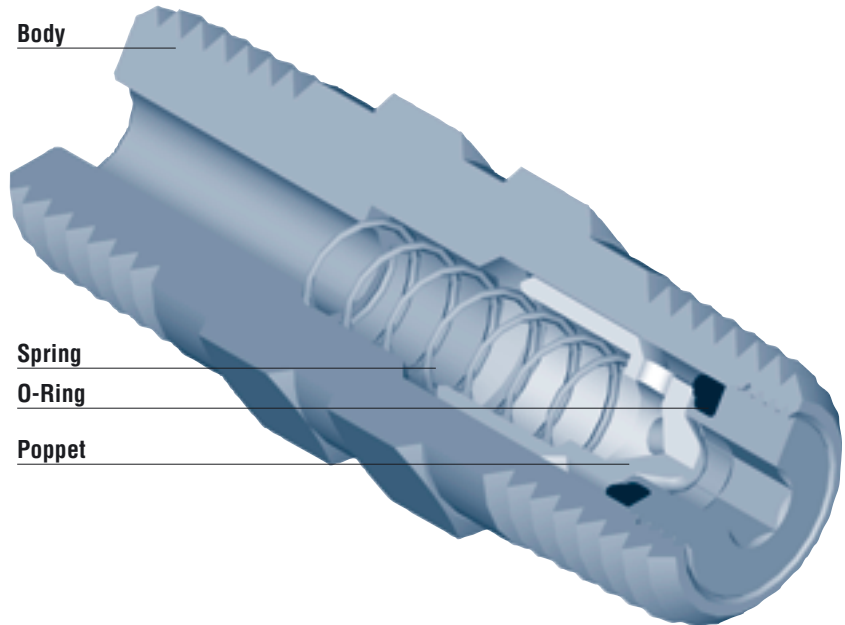

Springs

Spring material is 304 Stainless Steel as standard. 316 Stainless Steel available as an option. Please specify on order.

Deflector cap

Cap also available for the safe deflection of media when valve is used as a low pressure relief valve.

Testing

Waverley check valves have been tested for sealing performance based on BS 6755 Pt1. These tests consist of: Low pressure (50psi 3.5 bar)
High pressure shell (9,000psi 620 bar).

Seal kits

Seal kits are supplied for necessary maintenance and consist of poppet O-ring seal.

Cleaning and packaging

All check valves are dispatched fully degreased and sealed. Cleaning for oxygen use on application.

The Waverley brownall Manifold range of Precision Relief Valves and Strainers are manufactured to a very high standard in our own UK factory from top quality 316 stainless steel. Both products have a safe working pressure of 6000 psi and come in a wide range of inlet and outlet end connections from 1/8" to 1" in a variety of thread forms, including Ringlok and Duoloc compression ends.

The Relief Valve design features a range of colour coded springs to give the user the flexibility of choosing the relief pressure to exactly suit your application. The strainer or Inline Tee Filter is designed for liquid or gas applications and can be ordered with a wide range of different mesh or sintered size elements.

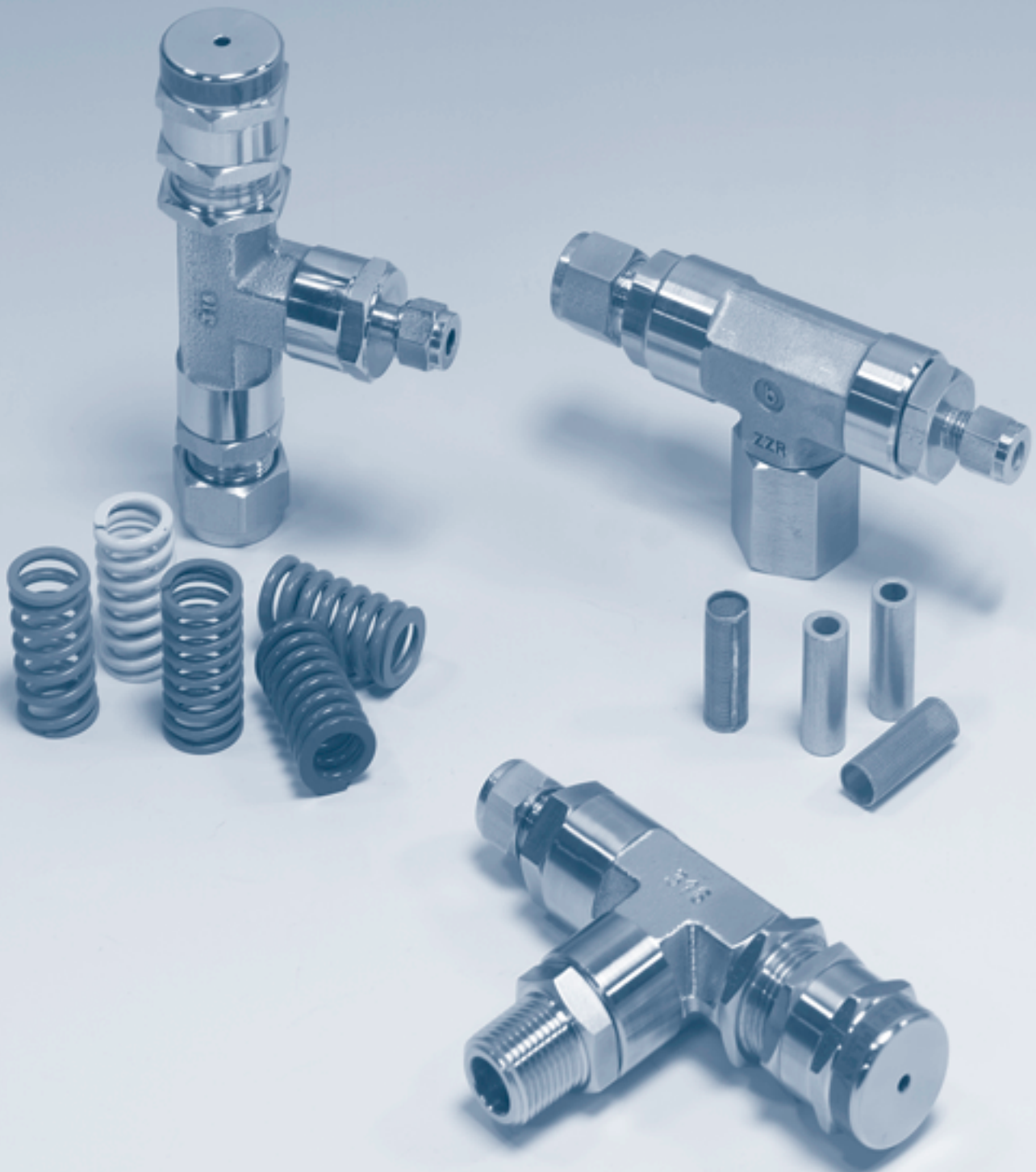

Operation

When inline pressure exceeds the force exerted by the spring, the valve stem opens. The flow through the valve is proportional to the increase in pressure. As the valve is balanced, cracking pressure is not effected by outlet back pressure. The relief valve setting is adjusted by rotating the adjustment cap.

Features

Maximum working pressure 6000psi

Cracking pressures from 100 to 6000psi

All 316 Stainless Steel construction with choice of seals

Range of end connections available including Double and Single ferrule OD Compression, BSP, BSPT, NPT



Technical specifications

Temperature ratings

Temperature range Viton	-20 to 200°C
Temperature range High Nitrile	-40 to 120°C
Cracking pressure	Adjustable from 100 to 6000psi
Maximum working pressure	6000psi
Outlet maximum working pressure	1500psi

Materials of construction

Top cap	316 stainless steel
Locking ring	316 stainless steel
Spring	316 stainless steel
Spring seat	316 stainless steel
Bonnet	316 stainless steel
O-ring	High Nitrile
Poppet seal	High Nitrile
Seal retainer	316 stainless steel
Poppet	316 stainless steel
Poppet guide	316 stainless steel
Seat seal High Nitrile	
Seat	316 stainless steel
Body	316 stainless steel

Spring selection chart

	PSI	Bar	Colour	Part
A	100-500	3.4-34	Yellow	PRV13
B	500-1000	34-68	Purple	PRV14
C	1000-2000	68-136	Orange	PRV15
D	2000-3000	136-204	Brown	PRV16
E	3000-4000	204-272	White	PRV17
F	4000-5000	272-340	Red	PRV18
G	5000-6000	340-408	Green	PRV19

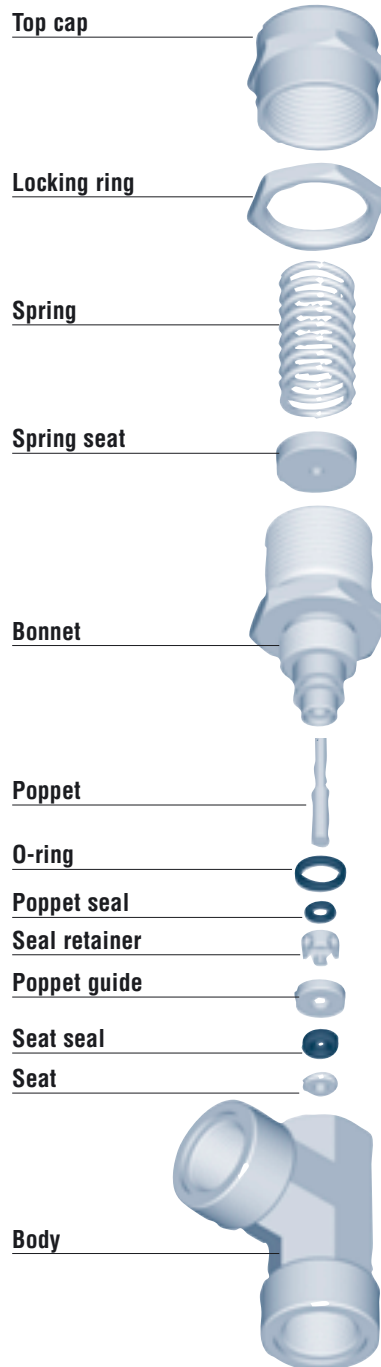

Cracking pressure

The cracking pressure on valves that have not been used for long periods of time may be above the set pressure.

Pre-set pressure

Valves ordered as standard will not have a pre-set relief setting. Relief valves may be pre-set to order.

Testing

Each valve is individually tested for pressure relief operation and sealing performance based on BS 6755 P1.

Air flow

- Cv = 0.42
- A set at 100psi
- A set at 500psi
- B set at 1000psi
- C set at 2000psi
- - - D set at 3000psi
- - - E set at 4000psi
- F set at 5000psi
- G set at 6000psi

inlet
pressure
psi

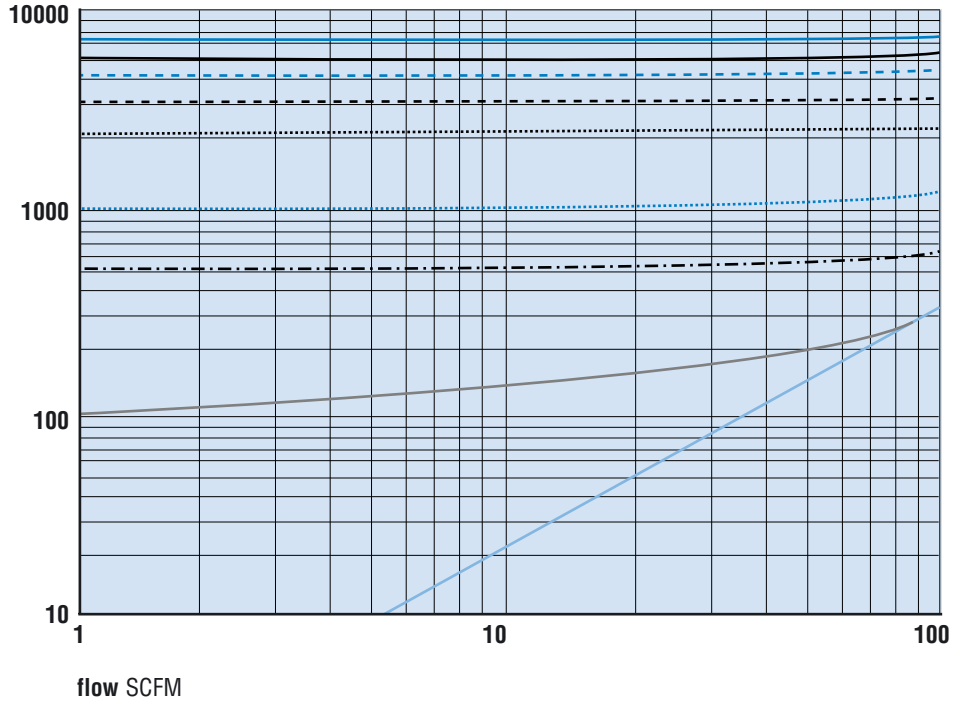

Water flow

- Cv = 0.42
- A set at 100psi
- A set at 500psi
- B set at 1000psi
- C set at 2000psi
- - - D set at 3000psi
- - - E set at 4000psi
- F set at 5000psi
- G set at 6000psi

inlet
pressure
psi

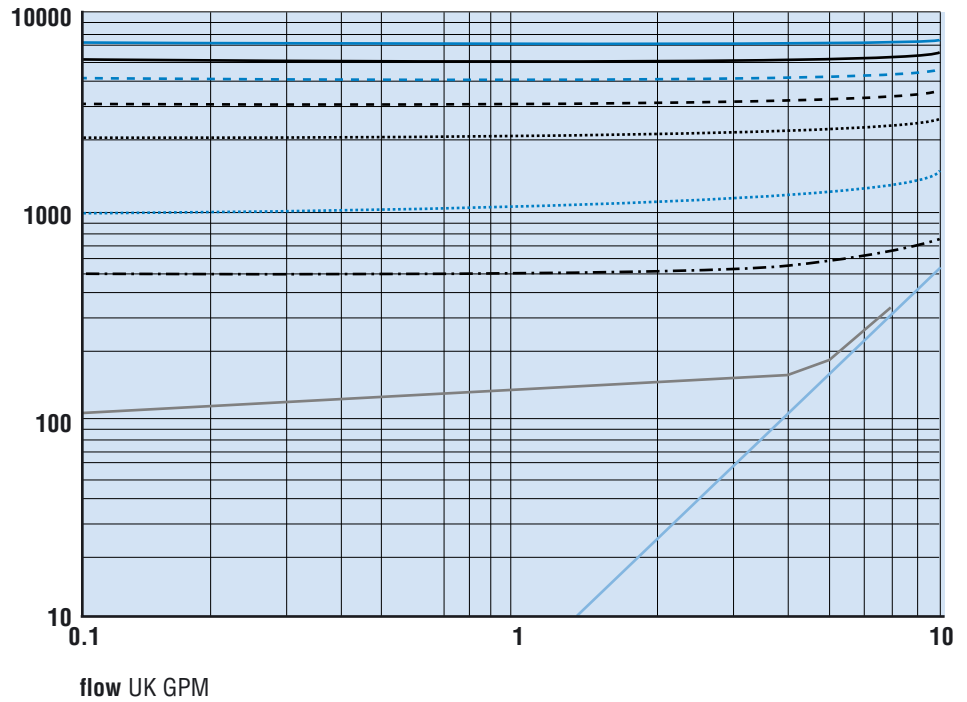

Duoloc® single ferrule OD compression

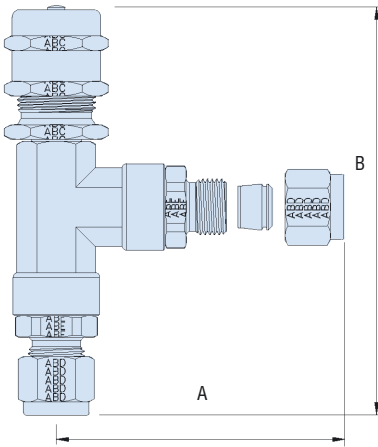

thread size	part number	A	B
1/8" O/D	PRV/10D	1.826"	4.700"
3/16" O/D	PRV/3/16OD	1.826"	4.700"
1/4" O/D	PRV/20D	1.826"	4.700"
3/8" O/D	PRV/30D	1.858"	4.732"
1/2" O/D	PRV/40D	1.857"	4.731"
6MM O/D	PRV/6MOD	47mm	165mm
8MM O/D	PRV/8MOD	46mm	164mm
10MM O/D	PRV/10MOD	46mm	165mm
12MM O/D	PRV/12MOD	46mm	165mm

Ringlok® double ferrule OD compression

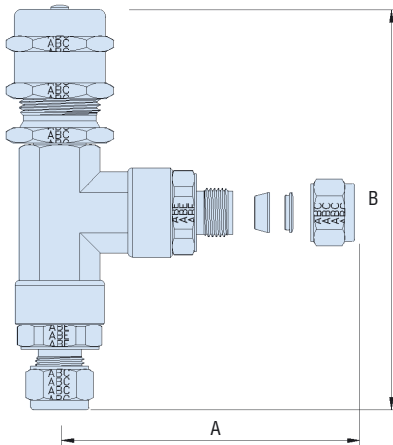

thread size	part number	A	B
1/8" O/D	PRV=10D	1.806"	4.680"
3/16" O/D	PRV=3/16OD	1.806"	4.680"
1/4" O/D	PRV=20D	1.808"	4.682"
3/8" O/D	PRV=30D	1.857"	4.731"
1/2" O/D	PRV=40D	1.744"	4.618"
6MM O/D	PRV=6MOD	45mm	163mm
8MM O/D	PRV=8MOD	46mm	164mm
10MM O/D	PRV=10MOD	45mm	163mm
12MM O/D	PRV=12MOD	43mm	159mm

Please state opening pressure or spring requirement when ordering.

Female/female

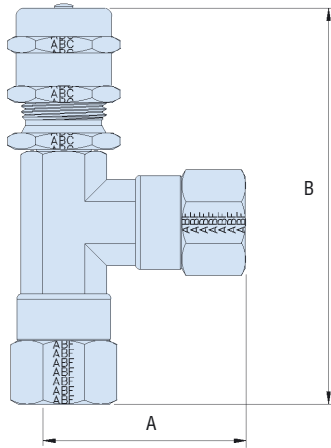

thread size	part number	A	B
G 1/4" BSP	PRV/2P	2.236"	5.110"
G 3/8" BSP	PRV/3P	2.416"	5.290"
G 1/2" BSP	PRV/4P	2.553"	5.427"
Rc 1/4" BSPT	PRV/2T	2.306"	5.180"
Rc 3/8" BSPT	PRV/3T	2.416"	5.290"
Rc 1/2" BSPT	PRV/4T	2.551"	5.425"
1/4" NPTF	PRV/2N	2.306"	5.180"
3/8" NPTF	PRV/3N	2.416"	5.290"
1/2" NPTF	PRV/4N	2.551"	5.425"

Male/male

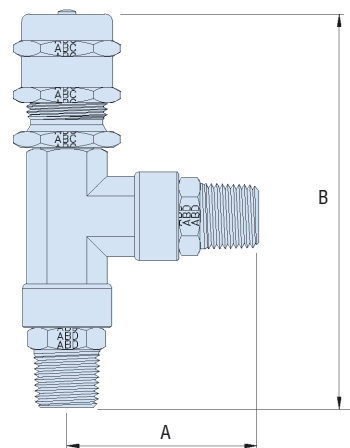

thread size	part number	A	B
G 1/4" BSP	PRV/2P/M	2.156"	5.030"
G 3/8" BSP	PRV/3P/M	2.236"	5.110"
G 1/2" BSP	PRV/4P/M	2.306"	5.180"
Rc 1/4" BSPT	PRV/2T/M	2.206"	5.080"
Rc 3/8" BSPT	PRV/3T/M	2.269"	5.143"
Rc 1/2" BSPT	PRV/4T/M	2.581"	5.455"
1/4" NPTF	PRV/2N/M	2.206"	5.080"
3/8" NPTF	PRV/3N/M	2.269"	5.143"
1/2" NPTF	PRV/4N/M	2.394"	5.268"

Please state opening pressure or spring requirement when ordering.

The Waverley brownall inline tee filter is designed to provide a simple solution for removing system contamination from flow media. It is designed for liquid or gas applications and for pressures of up to 6,000psi. It also incorporates a variety of elements and inlet and outlet port connections including single and double ferrule OD compression ends.

It should be noted when ordering, that the correct screen should be chosen. To choose a finer screen than is necessary will lead to early clogging and too coarse could damage downstream instrumentation.

Operation

Fluid passes through the outside of the element to the inside. This gives the largest possible area for filtration and minimises cleaning. It also ensures the element remains seated through pressure pulsations.

Features

- Maximum working pressure 6000psi
- 316 stainless steel construction
- Choice of elements from 15 to 400 micron
- Body remains in situ throughout cleaning
- Range of end connections

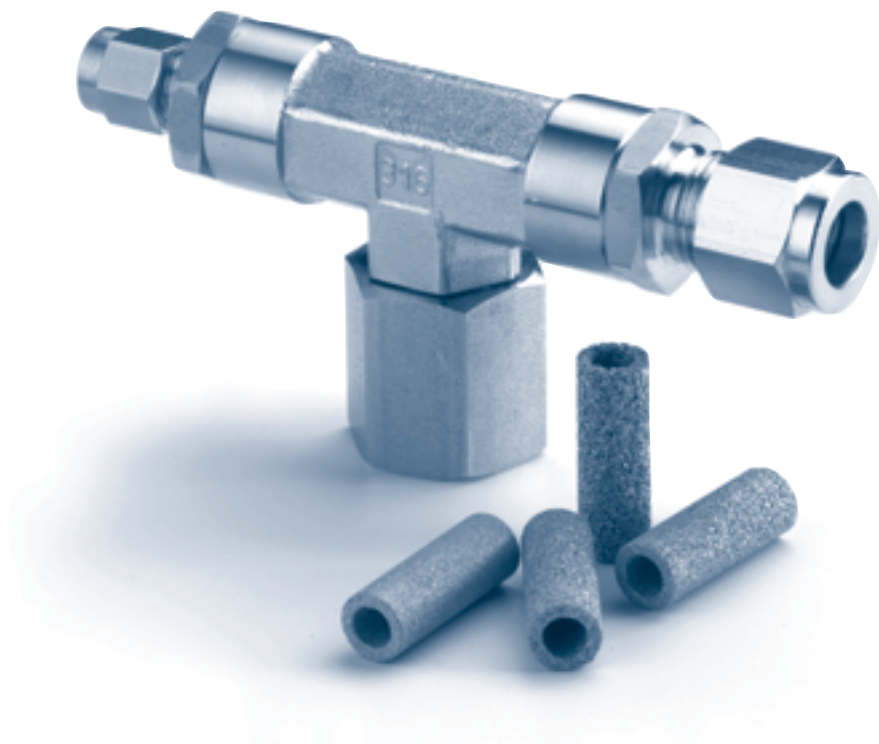

Technical specifications

Materials of constructions

Bonnet	316 stainless steel
Body	316 stainless steel
Sintered filter	316 stainless steel
O-ring	Viton
Back up ring	PTFE
Filter seat	PTFE
Filter cap	PTFE

Technical specifications

Pressure rating	6000psi
Temperature rating	-20 to 230°C
Sintered grades (µm)	
Mesh grades (µm)	15, 60, 100, 200, 400
Sintered element area (sq in)	1.708

Valve connections

NPT	ANSI/ASME B1-20.1
BSPT	BS21
BSP	BS2779

Valve markings

Make or manufacturer	Waverley
Direction arrow	
Pressure rating	6,000psi
Cast code	ABC
Filter grade	15 µm

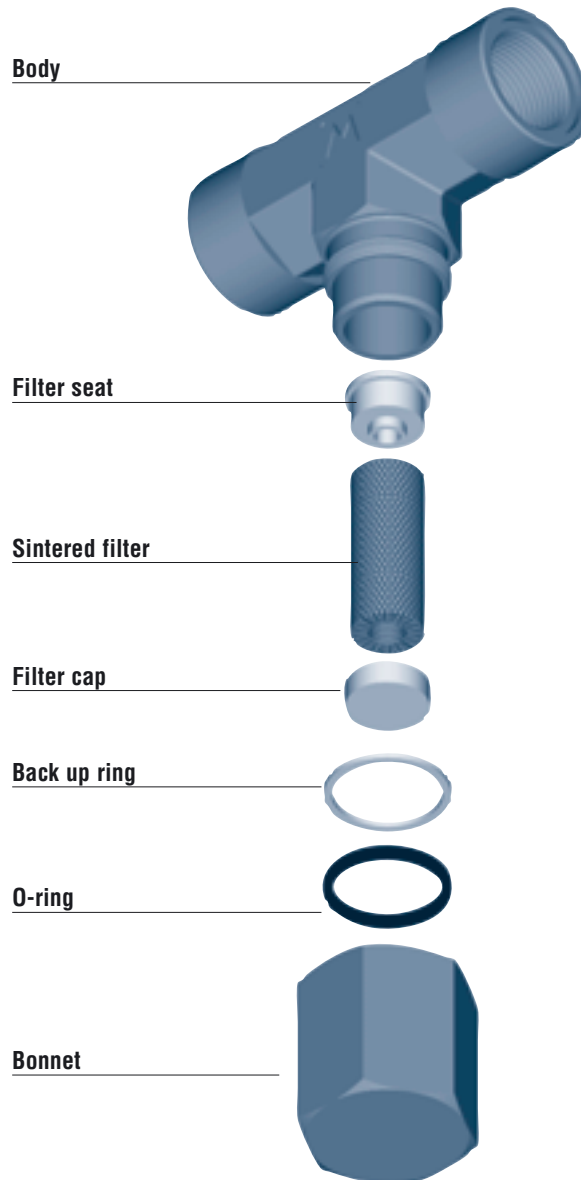

Installation and maintenance

It is recommended the filter is installed with the bonnet downwards. This reduces the risk of contamination during filter removal.

To clean or replace filter, unscrew the bonnet and withdraw the filter assembly. Replace or clean filter assembly and replace in bonnet. Screw back into body, re-seating filter assembly.

Valve connections

Waverley strainers are supplied threaded in male and female format to the following standards up to 1/2".

Valve connections

Compression fitting ends can also be supplied in the following format.

Ringlok® (Double Ferrule)
1/8" to 1/2" OD
Duoloc® (Single Ferrule)
1/8" to 1/2" OD

Valve markings

Each valve is marked with the information shown.

Testing

Waverley Tee Filters have been tested for sealing performance based on BS 6755 Pt1. These tests consist of:

Low pressure (50 psi 3.5 bar)
High pressure shell (9,000 psi 620 Bar)

Seal kits

Seal kits are supplied for necessary maintenance, and consist of O-rings and element retaining caps.

Cleaning and packaging

All Waverley filters are dispatched fully degreased and sealed. Cleaning for oxygen use on application.

Air flow

- 15 micron
- 60 micron
- - 100 micron
- - 200 micron

pressure drop psi

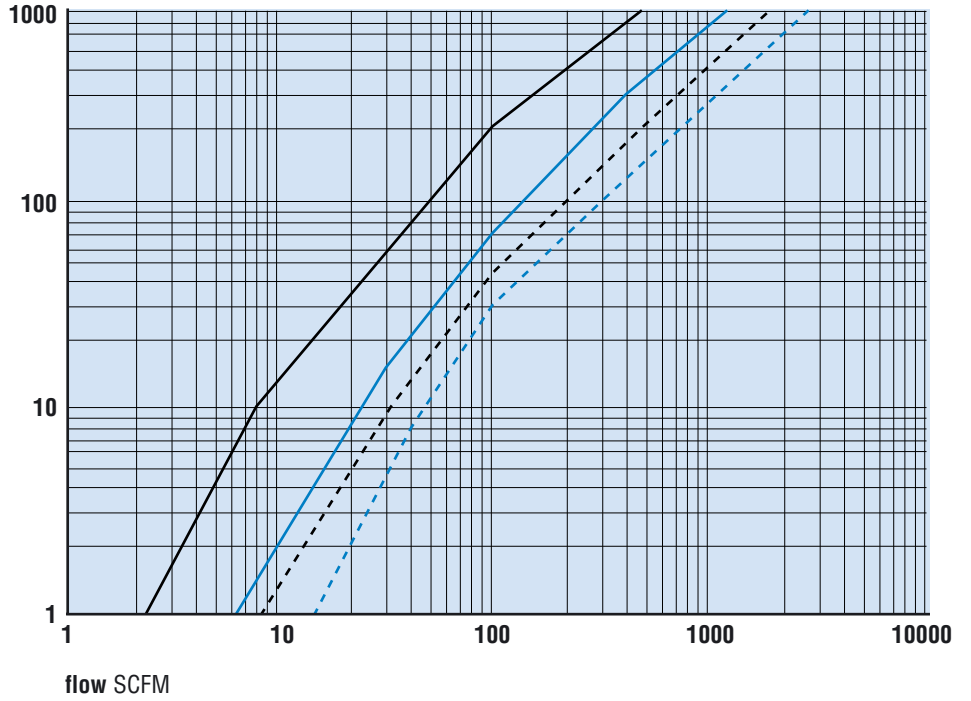

Water flow

- 15 micron
- 60 micron
- - 100 micron
- - 200 micron

pressure drop psi

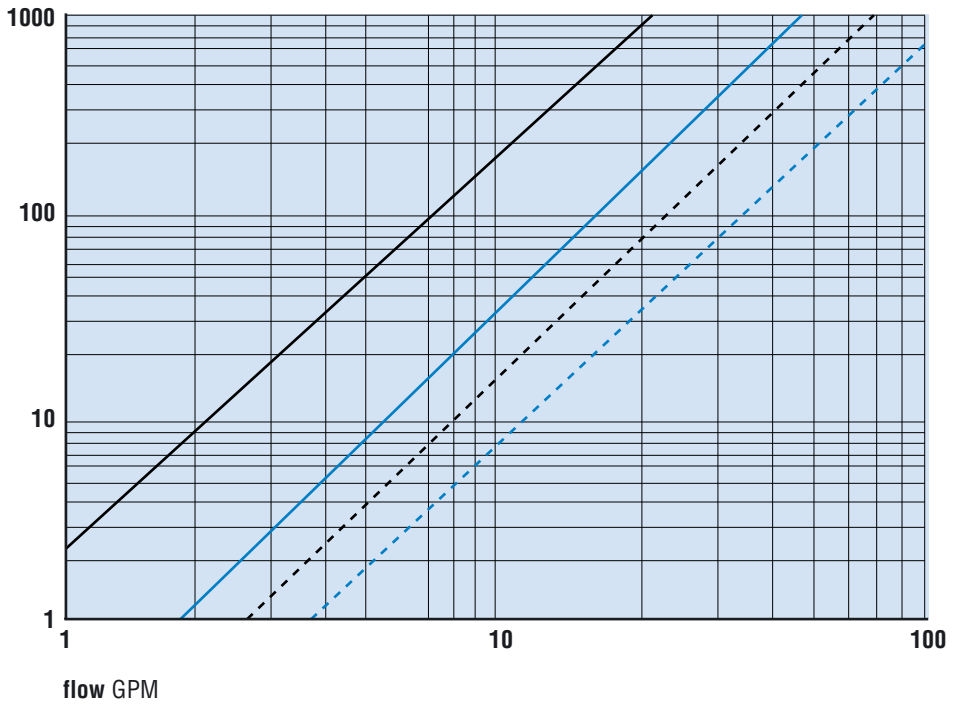

Female/female

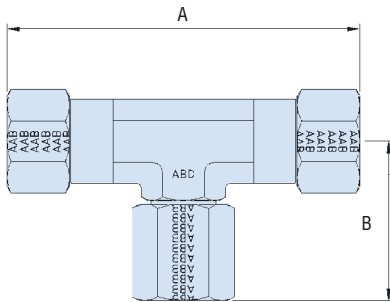

thread size	part number	A	B to C/L
G 1/4" BSP	ST/2P	4.394"	1.968"
G 3/8" BSP	ST/3P	4.754"	1.968"
G 1/2" BSP	ST/4P	5.028"	1.968"
Rc 1/4" BSPT	ST/2T	4.534"	1.968"
Rc 3/8" BSPT	ST/3T	4.754"	1.968"
Rc 1/2" BSPT	ST/4T	5.024"	1.968"
1/4" NPTF	ST/2N	4.534"	1.968"
3/8" NPTF	ST/3N	4.754"	1.968"
1/2" NPTF	ST/4N	5.024"	1.968"

Male/female

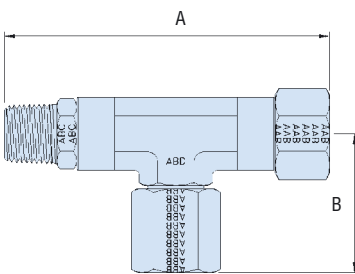

thread size	part number	A	B to C/L
G 1/4" BSP	ST/2P/MF	4.314"	1.968"
G 3/8" BSP	ST/3P/MF	4.574"	1.968"
G 1/2" BSP	ST/4P/MF	4.781"	1.968"
Rc 1/4" BSPT	ST/2T/MF	4.434"	1.968"
Rc 3/8" BSPT	ST/3T/MF	4.544"	1.968"
Rc 1/2" BSPT	ST/4T/MF	4.868"	1.968"
1/4" NPTF	ST/2N/MF	4.434"	1.968"
3/8" NPTF	ST/3N/MF	4.606"	1.968"
1/2" NPTF	ST/4N/MF	4.868"	1.968"

Male/male

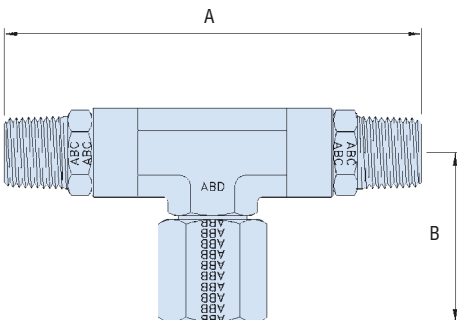

thread size	part number	A	B to C/L
G 1/4" BSP	ST/2P/M	4.234"	1.968"
G 3/8" BSP	ST/3P/M	4.394"	1.968"
G 1/2" BSP	ST/4P/M	4.534"	1.968"
Rc 1/4" BSPT	ST/2T/M	4.334"	1.968"
Rc 3/8" BSPT	ST/3T/M	4.459"	1.968"
Rc 1/2" BSPT	ST/4T/M	5.084"	1.968"
1/4" NPTF	ST/2N/M	4.334"	1.968"
3/8" NPTF	ST/3N/M	4.459"	1.968"
1/2" NPTF	ST/4N/M	4.709"	1.968"

Duoloc® single ferrule OD compression

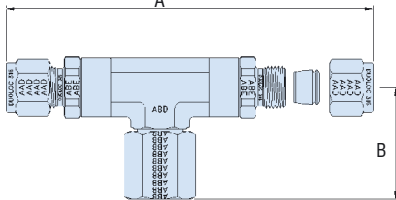

thread size	part number	A	B to C/L
1/8" O/D	ST/10D	2.240"	1.968"
3/16" O/D	ST/3/16OD	2.240"	1.968"
1/4" O/D	ST/20D	2.240"	1.968"
3/8" O/D	ST/30D	2.304"	1.968"
1/2" O/D	ST/40D	2.302"	1.968"
6MM O/D	ST/6MOD	58mm	50mm
8MM O/D	ST/8MOD	57mm	50mm
10MM O/D	ST/10MOD	57mm	50mm
12MM O/D	ST/12MOD	57mm	50mm

Ringlok® double ferrule OD compression

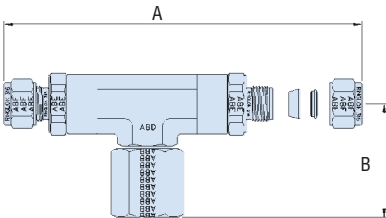

thread size	part number	A	B to C/L
1/8" O/D	ST=10D	3.534"	1.968"
3/16" O/D	ST=3/16OD	3.534"	1.968"
1/4" O/D	ST=20D	3.538"	1.968"
3/8" O/D	ST=30D	3.636"	1.968"
1/2" O/D	ST=40D	3.410"	1.968"
6MM O/D	ST=6MOD	89mm	50mm
8MM O/D	ST=8MOD	90mm	50mm
10MM O/D	ST=10MOD	89mm	50mm
12MM O/D	ST=12MOD	85mm	50mm

OTHER WAVERLEY BROWNALL PRODUCTS

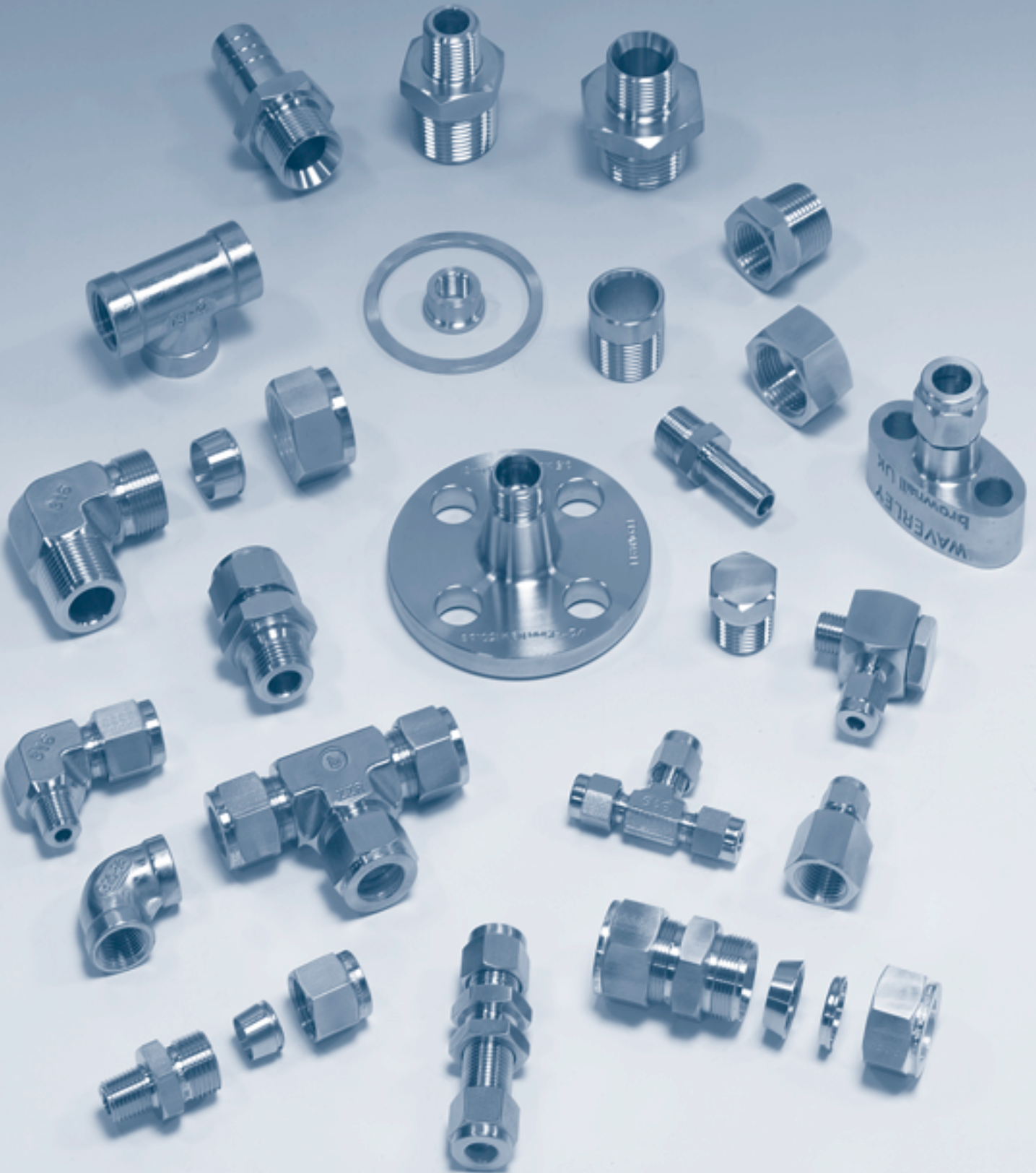

TWIN FERRULE COMPRESSION FITTINGS SINGLE FERRULE COMPRESSION FITTINGS

HIGH PRESSURE PRECISION PIPE FITTINGS
HOSE COMPONENTS AND UNIONS

LOW PRESSURE CAST PIPE FITTINGS
PLUGS, BUSHES AND SEALS



Ring Binder Book

The complete Waverley brownall range is also shown in detail in a ring binder for ease of reference.



Electronic Catalogue

The Waverley brownall electronic catalogue offers you a fast and accurate means of selecting the right 316 stainless steel fittings and valves for your instrumentation applications.



Pipe Fitting Catalogue

Shows our complete pipe fitting range including High Pressure Precision Fittings, Plugs, Bushes and Hose Components. Plus our Low Pressure Cast Range and Weld Fittings



Waverley brownall Ltd
46, The Vintners, Temple Farm Industrial Estate
Southend-on-Sea, Essex SS2 5RZ
Tel: +44 (0)1702 600014
Fax: +44 (0)1702 613600
email: sales@waverleybrownall.co.uk
www.waverleybrownall.co.uk
Waverley brownall Scotland
Tel: +44 (0)1224 877323

