

# PRODUCT GUIDE



British Lead

# EXPERIENCE LEAD SUPERIORITY



## CONTENTS

About Us .....	3
Recycling Lead.....	4
Rolled Lead Sheet .....	6
Ancillary Products .....	10
Health & Safety .....	30
Basic Fitting Guides.....	32
Technical Support .....	40
and Training	

## LEAD

Lead is a naturally occurring heavy metal that is soft, malleable and corrosion-resistant. It is one of the oldest and most durable building materials commonly used today. Lead is widely used in the construction of buildings as an effective and traditional roofing material that is totally weather resistant and provides a lasting protection and attractive finish.

When correctly sized and fitted, British Standard Rolled Lead Sheet has a life expectancy of between 60-100 years, far exceeding any man-made alternative product and benefits from a significantly lower life time cost.

It is the professional's choice for flashings, cladding, valley gutters, dormers, porches and flat and pitched roofing of both traditional and contemporary buildings.



British Lead



## ABOUT US

Proudly manufacturing Lead products in the UK since 1932, BLM British Lead was founded on the principle of bringing the best quality Lead Sheet to its customers. Our wealth of experience and expertise, together with the advanced technology at our disposal, ensures that BLM's Rolled Lead Sheet meets the strict tolerances of British Standard BS EN 12588, allowing Lead Sheet's performance to be accurately predicted whilst in situ.

Three rolling mills give us the capacity to produce in excess of 60,000 tonnes of Rolled Lead Sheet annually and enable us to offer the widest range of sizes in the UK. Our manufacturing site in Welwyn Garden City, Hertfordshire handles all aspects of Lead Sheet production, from recycling soft scrap Lead, rolling slabs of Lead into sheets and quality testing, through to cutting, packing and distribution.

Being a member of the ECOBAT Technologies Group, the world's largest producer and recycler of Lead, ensures 100% of the raw material used to manufacture our Rolled Lead Sheet is either

recycled by BLM or our sister companies. Every kilogram of Lead we produce has had a previous life.

The combination of our own delivery vehicle fleet and external logistic partners, supported by BLM's collection and distribution depot in Glasgow ensure complete nationwide coverage and enhanced lead times.

BLM's offer is complimented by our comprehensive range of ancillary products, which provides our customers with everything required to install anything from basic flashings to the most complex detailed Leadwork.

We also provide a specialist leadwork and roofing tools range, BLM Roofing Tools. All tools products are made in Britain and come with a lifetime material defects warranty.

We are certified to the internationally recognised ISO 9001 for Quality Management, ISO 14001 for Environmental Management, OHSAS 18001 for Occupational Health & Safety and ISO 50001 for Energy Management.

# RECYCLING LEAD

One of the key elements to BLM's production process is recycling scrap Lead comprising reclaimed Lead Sheet, Lead pipe and off-cuts from our manufacturing process, turning waste in to new products and preventing their disposal in landfill.

Lead has one of the highest recycling rates in the world which makes it one of the most sustainable and environmentally friendly building products.

Lead recycling makes an important contribution to achieving and maintaining sustainable development in the construction industry through a simple and energy-efficient recovery process.

The relatively low melting point of Lead, 327°C, means the process is very energy efficient with a low carbon footprint and a minimal environmental impact.

The end product is a 100% recycled Lead Sheet providing the best performance and longevity for Leadwork.

Our Scrap Back scheme offers contractors buying regularly from BLM supplied merchants the chance to return their scrap Lead at preferential rates, further underlining BLM's commitment to recycling and sustainability. Further details can be found on page 43.

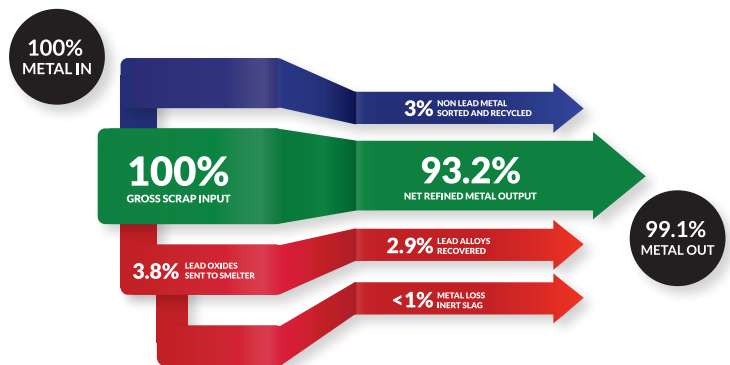



# ECOBAT

TECHNOLOGIES

ECOBAT Technologies are the world's largest producer and recycler of Lead, operating from 29 plants in 8 countries and employing over 3,500 people. The combined group recycles and processes in excess of 1,000,000 tonnes of Lead per year.

In addition to producing new Lead products for the construction and shielding industries, other ECOBAT group members specialise in the collection, transport, storage and recycling of spent Lead acid batteries, production of specialist Lead alloys and distribution of new Lead acid batteries. This provides "closed loop recycling" for Lead acid batteries, making ECOBAT completely unique from any other global battery recycling business.

By-products resulting from the recycling of batteries, such as high quality polypropylene, gypsum, sulphuric acid, sodium sulphate and precious metals including gold and silver are supplied to a range of different industries.

The group utilises best available technology at its sites worldwide and shares information and best practise to ensure the continued development of quality standards and efficiency. This ensures that the critical environmental and health and safety management elements of our operations remain consistently high and always ahead of all applicable legal requirements.

While BLM is largely self-sufficient in terms of its raw material sources, customers can rest assured that being part of ECOBAT guarantees continued supply from a globally recognised group, where advances in technology and innovation are at the forefront of everything it does.

# ROLLED LEAD SHEET

BLM's Rolled Lead Sheet is manufactured to British Standard BS EN 12588 and made from 100% recycled raw material.

The British Standard ensures the alloy used contains a minimum amount of Lead and the correct amount of trace elements. It also guarantees a consistent thickness (+/- 5%) and grain structure, so its performance can be accurately predicted to provide maximum lifespan for correctly fitted Lead Sheet used in construction.

We supply Rolled Lead Sheet in six standard Code thicknesses, in 5mm width increments from 150mm to 1500mm in Code 3 and up to 2440mm in Codes 4,5,6,7 and 8 in standard roll lengths of 3 and 6 metres.

Non-standard lengths and thicknesses are available upon request. Please be aware that extra charges and extended lead times may be applied.

British Standard Rolled Lead is produced to a calculated theory weight with a tolerance of +/- 5%. Theory weights of standard rolls can be found on the BLM Weight Chart.

## **Peace of Mind**

BLM's Rolled Lead Sheet comes with a 50 year warranty providing it is installed in accordance with the LSTA's Rolled Lead Sheet Manual and BS 6915.

Lead Sheet applications also achieve a rating of A or A+ in the BRE Green Guide.



## **Helpful Tips**

- If the width you require is not in stock it is worth ordering a wider piece to avoid delay.
- Save on cutting charges by ordering a standard length and cutting it yourself.
- Large orders of Lead can be delivered direct to site at no extra cost.
- Lead Sheet should be fitted in accordance with BS 6915 as detailed in Rolled Lead Sheet – The Complete Manual by the LSTA.

## WEIGHT CHART

		CODE 3		CODE 4		CODE 5		CODE 6		CODE 7		CODE 8	
Weight per m <sup>2</sup>		15.0kg		20.41kg		25.40kg		30.10kg		35.72kg		40.26kg	
Nominal Thickness		1.32mm		1.80mm		2.24mm		2.65mm		3.15mm		3.55mm	
Standard Lengths		3m	6m	3m	6m	3m	6m	3m	6m	3m	6m	3m	6m
Widths mm	Widths Nearest imperial	kg	kg	kg	kg	kg	kg	kg	kg	kg	kg	kg	kg
150	6"	7	13	9	18	11	23	14	27	16	32	18	36
180	7"	8	16	11	22	14	27	16	32	19	39	22	43
210	8"	9	19	13	26	16	32	19	38	23	45	25	51
240	9"	11	22	15	29	18	37	22	43	26	51	29	58
300	12"	13	27	18	37	23	46	27	54	32	64	36	72
360	14"	16	32	22	44	27	55	32	65	39	77	43	87
390	15"	18	35	24	48	30	59	35	70	42	84	47	94
450	18"	20	40	28	55	34	69	41	81	48	96	54	109
510	20"	23	46	31	62	39	78	46	92	55	109	62	123
600	24"	27	54	37	73	46	91	54	108	64	129	72	145
760	30"	34	68	47	93	58	116	69	137	81	163	92	184
800	32"	36	72	49	98	61	122	72	144	86	171	97	193
900	36"	40	81	55	110	69	137	81	162	96	193	109	217
1000	40"	45	90	61	122	76	152	90	180	107	214	121	242
1220	48"	55	110	75	149	93	186	110	220	131	261	147	295
1500	60"	67	135	92	184	114	229	135	270	161	321	181	362
2440	96"	-	-	149	299	186	372	220	440	261	523	295	589

To calculate the approximate weight: Length in metres x Width in metres x Code weight in kg/m<sup>2</sup>

## Sizing and Correct Use of Lead Sheet

The most common cause for failure of Lead Sheet used in roofing and cladding applications is from cracks developing as a result of thermal expansion and contraction due to individual pieces of Lead being oversized.

The maximum size recommended for each thickness or Code of Lead varies; the thicker the Lead the larger the piece that can be laid.

The Lead Sheet Training Academy provide comprehensive details of recommended maximum sizes in "Rolled Lead Sheet – The Complete Manual", the chart opposite provides a general guide to which code thicknesses can be used for a range of common applications as well as maximum recommended sizes.

### Over Fixing

Lead Sheet on buildings is usually fixed externally and is therefore subjected to conditions of changing temperature.

Limiting the size of each piece of Lead Sheet ensures that the amount of thermal movement within the jointing and fixing details is not excessive and there are no undue restrictions on this movement.

Whilst there needs to be sufficient fixings to support the Lead, it is important to note that over fixing can restrict the free thermal movement of the Lead, causing the sheet to buckle, which in turn will result in fatigue cracking and possible failure.

### Joints

Joints for Leadwork are designed to allow for thermal movement. A joint must be weather-tight in its selected position and not formed too tightly.

End to end joints between step and cover flashings, pitched valley gutters, pitched roofing and cladding pieces are called laps. The lap diagram below indicates the minimum lap required for each degree of pitch.

## Lap Graph

Minimum lap for each degree of pitch

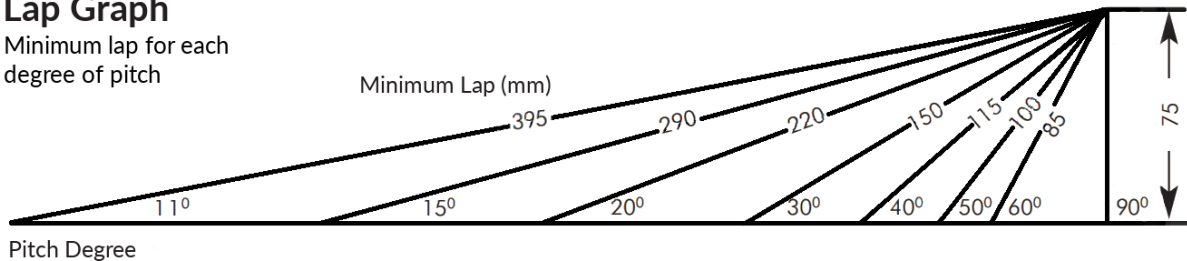



## SIZING GUIDELINES BY APPLICATION

	CODE 3	CODE 4	CODE 5	CODE 6	CODE 7	CODE 8
Nominal Thickness	1.32mm	1.80mm	2.24mm	2.65mm	3.15mm	3.55mm
Weight per m <sup>2</sup>	15.0kg	20.41kg	25.40kg	30.10kg	35.72kg	40.26kg
Uses (see key below)	A	ABCEF	BCDEFGH	BCDEGH	CDEGH	CDEGH
<b>FLASHINGS</b>						
Maximum length of flashings and pitched valley gutters		1500mm	1500mm			
Maximum length of flashings to verges of asphalt and felt roofs		1000mm	1000mm			
Maximum length of ridge roll cappings		1500mm	2000mm	2000mm		
Maximum length of hip roll cappings		1500mm	1500mm	1500mm		
<b>GUTTERS - BOXED OR TAPERED</b>						
Maximum spacing of drips			2000mm	2250mm	2500mm	3000mm
Maximum overall girth			800mm	850mm	900mm	1000mm
<b>FLAT ROOFS AND DORMER TOPS - 10° OR LESS</b>						
Maximum spacing of drips			2000mm	2250mm	2500mm	3000mm
Maximum spacing of joints with the fall			600mm	675mm	675mm	750mm
<b>PITCHED ROOFS - UP TO 60°</b>						
Maximum distance between laps			2000mm	2250mm	2400mm	2500mm
Maximum spacing of joints with the fall			600mm	675mm	675mm	750mm
<b>PITCHED ROOFS - ABOVE 60° UP TO AND INCLUDING 80°</b>						
Maximum distance between laps			2000mm	2250mm	2250mm	2250mm
Maximum spacing of joints with the fall			600mm	675mm	675mm	750mm
<b>VERTICAL CLADDING AND DORMER CHEEKS</b>						
Maximum distance between laps		1500mm	2000mm			
Maximum spacing of vertical joints		500mm	600mm			

A Soakers

B Flashings

C Pitched Valley Gutters

D Parapet, Box and Tapered Valley Gutters

E Dormers

F Vertical Cladding

G Flat Roofing

H Pitched Roofing

# ANCILLARY PRODUCTS

## PATINATION OIL

When newly fitted Lead is exposed to rain or moisture it builds up a natural patina in the form of a soluble Lead carbonate. Future exposure to rain can wash the carbonate on to adjacent materials causing staining or discolouration.

Patination Oil is a white spirit based surface treatment that prevents Lead carbonate from forming on the surface of newly fitted Lead Sheet and ultimately helps prevent staining to adjacent materials.

Patination Oil should be applied to Lead roofing, flashings and cladding to give a uniform, attractive appearance where the Lead is visible. It is also necessary when water flowing from the Lead Sheet surface may come into contact with other visible building materials.

- Prevents white carbonate forming on newly fitted Lead.
- Provides a uniform, attractive appearance to new Leadwork.
- Easy to use.



### Application:

- Apply with a clean soft cloth immediately after fixing, before the Lead gets wet and by the end of the working day.
- Apply to the Lead working horizontally or vertically in straight lines.
- The leading edge and underside of the sheet should be coated to a depth of 75mm.
- Patination Oil should be applied with care when the Lead is near UPVC and bitumen.
- Wear suitable gloves.

### Packaging and Coverage:

- Available in 1.0 litre and 0.5 litre cans.
- One litre covers approximately 60m<sup>2</sup>.

*A Product Data Sheet and H&S Data Sheet giving full handling, use and storage advice are available from our website [www.britishlead.co.uk](http://www.britishlead.co.uk).*

## LEAD-COTE

Lead-Cote is a water based alternative to Patination Oil, providing an environmentally friendly protective coating for Lead applications.

Lead-Cote should be used on Lead roofing, flashings and cladding to give a uniform, attractive appearance where Lead Sheet is visible. It is also necessary when water flowing from the Lead Sheet surface may come into contact with other visible building materials. Lead Cote is also recommended to use when working close to UPVC and bitumen based materials.

- Prevents white carbonate forming on newly fitted Lead.
- Solvent free, water based alternative to Patination Oil.
- Provides a uniform, attractive appearance to new Leadwork.
- Safer and easier to use than Patination Oil.

### Application:

- Spray on to a clean soft cloth, then wipe on to the Lead.
- Work horizontally or vertically in straight lines.
- The leading edge and underside of the sheet should be coated to a depth of 75mm.
- Apply at least two coats.
- Can be applied to Lead up to 2 weeks after it has been exposed to moisture.
- Wear suitable gloves.

### Packaging and Coverage:

- Available in 500ml spray-gun containers.
- Coverage is between 40m<sup>2</sup>-60m<sup>2</sup> per litre, per coat.



A Product Data Sheet and H&S Data Sheet giving full handling, use and storage advice are available from our website [www.britishlead.co.uk](http://www.britishlead.co.uk).

## HALL CLIPS

When Lead flashings are installed, they are secured in place into the chase of the brickwork or masonry. The traditional method for fixing flashings is to use Lead wedges. However, this method can sometimes cause flashings to come loose. Hall Clips are a fast and effective alternative to wedges. They are high tensile 'V' shaped stainless steel clips, designed by a roofing contractor to save time and provide a more secure fixing. They hold the Lead flashings in position so that they can be dressed down in to place. Standard Hall Clips should be used when fixing flashings in a 6mm -18mm chase. Hall Clips Plus can be used for chase heights of 18mm-26mm.

- Gives a professional finish to linear and step flashings.
- Provides a secure fixing.
- Fast, convenient and easy to use.
- Improves installation time.
- Helps prevent theft.



### Application:

- Insert with 'H' uppermost.
- Easily secured with screwdriver or similar tool.
- For step flashings use at least one clip per step.
- Two clips should be fitted per single step flashings.
- For linear flashings Hall Clips should be fitted at 450mm centres at laps and 50mm in from each end.
- Flashings lengths should not exceed 1.5 metres.
- Use in combination with BLM Lead Pointing Sealant for a clean finish.

### Packaging and Coverage:

- Standard Hall Clips: available in packs containing 50 clips each; each pack fixes up to 20 linear metres of flashings.
- Hall Clips Plus: available in packs containing 25 clips each; each pack fixes up to 10 linear metres of flashings.

## LEAD POINTING SEALANT

The most common reason for water penetration at an abutment is failure of the mortar used to point the joint between Lead flashings and the brickwork or masonry. This is due to the mortars inability to expand and contract at the same rate as the Lead during temperature changes. The mortar can crack and fall out, allowing water to penetrate the joint and subsequently cause dampness within the building fabric.

BLM Lead Pointing Sealant provides a simple solution to this problem; a low modular, non-corrosive, neutral cure silicone sealant which can be applied easily using a mastic gun.

- Ensures long-term protection against water penetration.
- Coloured grey to blend in with the Leadwork.
- Unique formula allows the Lead to expand and contract without cracking.
- Fast and easy to apply.
- Average tack free time is approximately 30 minutes.

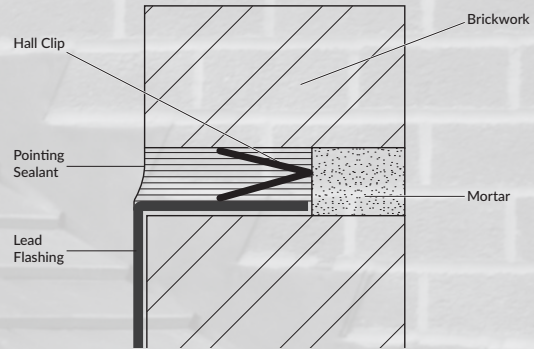

### Application:

- Ensure the chase is dry and free from debris and dust before applying.
- The nozzle on the sealant tube can be cut to suit the width of the chase to be filled.
- Minimum depth of sealant not less than 25mm.
- For chase heights of 6mm-18mm use – BLM Hall Clips to secure the Lead flashings in place.
- For chase heights over 18mm – use Hall Clip Plus or turn up the Lead flashings at the back of the chase and screwed to the wall using stainless steel screws.
- Flashing lengths should not exceed 1.5 metres.

### Packaging:

- Available in 310ml tubes.



*A Product Data Sheet and H&S Data Sheet giving full handling, use and storage advice are available from our website [www.britishlead.co.uk](http://www.britishlead.co.uk).*

## STANDARD LEAD SLATE

Lead Slates are used where a pipe penetrates a roof covering to provide a weathertight joint. They can be used on tiled, asphalt, felt and slate roofs.

BLM Standard Lead Slates are manufactured using Code 4 Rolled Lead Sheet with a cylindrical upstand that can be made to fit any diameter pipe and roof pitch. A range of standard outlet sizes and pitches are available from stock. For deeply profiled tiles, larger base sizes with adequate weathering laps can be manufactured to order.

- Standard Lead Slates suit roof pitches of 30°-40° and 90° angles for flat roofs and vertical outlets.
- Made to suit 75mm, 100mm, 125mm and 150mm outside pipe diameters.
- Provides a weathertight joint.
- Craftsman made.
- Saves welding.
- No maintenance required.



### Application:

- Ensure in all cases that slates/tiles are fitted closely to the soil pipe.
- A welt should be formed on the upper edge of the base before the tiles are fitted to prevent any driven rain penetrating the roof structure.
- For plastic pipes, a standard plastic collar should be solvent cemented to the top of the pipe to provide a watertight weathering.
- For cast iron pipes, once in position, the top edge of the upstand should be dressed into the pipe for weathering purposes.
- Apply Patination Oil to prevent unsightly carbonate from staining adjacent materials.

### Dimensions:

- Outlet diameters: 75mm, 100mm, 125mm and 150mm.
- Base size: 450mm x 450mm and minimum upstand height 150mm.
- Non-standard sizes can be supplied to special order to suit different diameters and roof pitches.

A Product Data Sheet is available from our website [www.britishlead.co.uk](http://www.britishlead.co.uk).

## QUICKSLATE

BLM Quickslates provide a simple but effective weatherproofing solution where a pipe penetrates a roof. They consist of a rubber cone vulcanized on to a Lead slate base, manufactured from Code 4 Rolled Lead Sheet. The malleability of the Lead base means that unlike similar products that employ aluminium or hard metal bases, BLM Quickslates can be easily shaped or dressed to suit almost any roof profile.

Quickslates are suitable for use where flue pipes and soil stacks penetrate slate, tile, felt and asphalt covered roofs. They are suitable for gas flues, withstanding temperatures of 150°C. Available to suit pitches of 0°-20° for flat roofs and vertical outlets and 20°-40° for pitched roofs. Quickslates can be cut to suit most pipe diameters up to 125mm.

- Provides a weathertight joint.
- Cheaper and easier to fit than hard metal alternatives.
- No maintenance required.

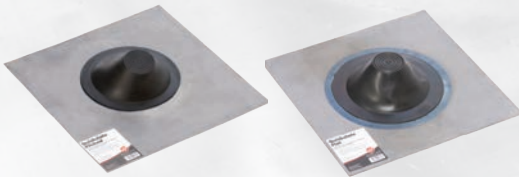

### Application:

- Cut the rubber to suit your pipe diameter.
- Always cut the aperture in the rubber slightly smaller than the required diameter to ensure a weathertight fit.
- Do not cut beyond the outer ring or into the wall of the upstand.
- Use a water based lubricant or silicone grease to lubricate the neck of the rubber sleeve of the Quickslate prior to fitting.
- A welt should be formed on the upper edge of the base before the tiles are fitted to prevent any driven rain penetrating the roof structure.
- Use Lead-Cote to prevent unsightly carbonate from staining adjacent materials.
- It is advisable to use Lead-Cote instead of Patination Oil on Quickslates to prevent damage to the rubber



### Dimensions:

- Base dimensions: 450mm x 450mm.
- Pipe sizes: Can be cut to suit outside pipe diameters up to 125mm.

A Product Data Sheet is available from our website [www.britishlead.co.uk](http://www.britishlead.co.uk).

## UNISLATE

BLM Unislates provide a complete weatherproofing solution where flue pipes and soil stacks penetrate a slate or profiled tile roof. Manufactured from Code 4 Rolled Lead Sheet with a conical upstand, Unislates suit 100mm-125mm outside pipe diameter and roof pitches between 20°-40°.

- Provides a weathertight joint.
- Effective for use with profiled tiles.
- Saves welding.
- No maintenance required.

### Application:

- Unislates may be fitted in place when tiles are being laid and before the pipe is installed.
- Ensure that slates/tiles are fitted closely to the soil pipe.
- A welt should be formed on the upper edge of the base before the tiles are fitted to prevent any driven rain penetrating the roof structure.
- Apply Patination Oil to prevent unsightly carbonate from staining adjacent materials.

### Dimensions:

- Base dimensions: 540mm x 480mm and minimum upstand 150mm.
- Pipe sizes: 100mm-125mm outside pipe diameter.



A Product Data Sheet is available from our website [www.britishlead.co.uk](http://www.britishlead.co.uk).



## SOAKERS

Soakers are an integral part of a slate or plain tile roof at its abutment with a wall, providing an effective weatherproofing solution when used in conjunction with step flashing.

BLM pre-formed Aluminium Soakers are becoming an increasingly popular product for roofing contractors. Further speeding up installation, they are a durable, lightweight alternative to traditional Lead soakers, which are pre-cut and bent to a 90° angle to provide a suitable upstand and cover between tile or slate courses.

Soakers are suitable for double lapped plain tiles and slates, but should never be used with interlocking tiles (single lap) as the soakers would not be supported under the tiles.

- Quick and easy to install.
- Will not warp, crack or discolour.
- 25 soakers per pack.
- Available in a range of sizes to suit double lapped plain tiles and slates.



### Application:

Soakers are installed between successive slate or tile courses at the headlap and are fully supported by the slate or tile below. The top edge of the soaker is turned down at right angles by 25mm to form a nib that hooks onto the top edge of the plain tile, or the slate batten to prevent it from slipping.

The length of a soaker is equal to the tile gauge (batten centres) + headlap + the turn over at the top of the tile.

The width of the soaker should be a minimum of 7" or 175mm, which is bent at a right angle to allow for 75mm up the wall and 100mm over the tile.

Salt water can accelerate corrosion to aluminium, it is therefore not advisable to use aluminium soakers on buildings exposed to a marine atmosphere.

### Dimensions:

(Length/Width/Height)

150mm x 100mm x 75mm (6" x 4" x 3")

175mm x 100mm x 75mm (7" x 4" x 3")

300mm x 100mm x 75mm (12" x 4" x 3")

335mm x 100mm x 75mm (13½" x 4" x 3")

Further sizes are available, please contact us for more information.

*A Product Data Sheet is available from our website [www.britishlead.co.uk](http://www.britishlead.co.uk)*

## BUILDING PAPER

Lead fitted to a roof in applications including gutters, vertical cladding, pitched and flat roofing, firstly require the correct ventilation detail to be incorporated into its design. This prevents the build-up of condensation which can cause corrosion to the underside of the Lead.

To protect the underside of Lead Sheet from corrosive attack from concrete, stone, screed, oak and plywood substrates, the Lead should be isolated from the substrate using Building Paper.

BLM Grade A1F Building Paper is a traditional, reinforced bitumen-bonded building paper laminate, manufactured with wet-strength Kraft paper, meeting the technical requirements of BS 1521 Class A.

- Protects the underside of Lead from alkalis in concrete, stone and screed surfaces.
- Reduces corrosive attack when laying Lead onto oak and plywood substrates.

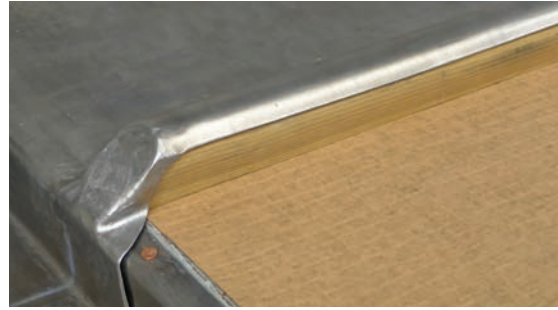

### Application:

- Rolled Lead Sheet over 600mm wide should have an underlay fitted.
- Smaller widths may require an underlay depending on the application.
- Building Paper should be laid across the fall of a roof.
- Adjacent sheets should be overlapped.
- Must be fitted over the whole substrate area.
- Avoid forming hot joints above Building Paper.

### Dimensions:

- Available in 25m x 1.0m rolls.

A Product Data Sheet is available from our website [www.britishlead.co.uk](http://www.britishlead.co.uk).

## STANDARD UNDERLAY

BLM Standard Underlay is used to isolate the Lead from timber board substrates with penny air gaps providing the correct ventilation detail has been incorporated. This prevents the build-up of condensation which can cause corrosion to the underside of the Lead.

BLM Standard Underlay is a non-woven, crimped filament polyester, needle punched to allow air to circulate freely between the underside of the Lead Sheet and the roof decking. It also ensures the Lead can expand and contract freely with temperature changes, effectively smoothing out the surface of the substrate.

- Helps to prevent condensation forming and corroding the underside of the Lead.
- Allows the Lead to expand and contract freely during thermal movement.
- Resistant to high temperatures.
- Prolongs the life of correctly fitted Lead Sheet.

**For concrete, stone, screed, oak and plywood substrates, BLM Grade A1F Building Paper should be used.**

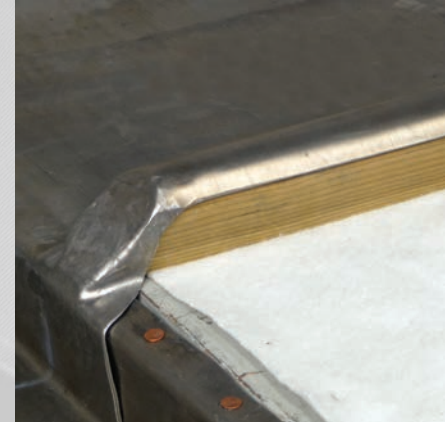

### Application:

- All Rolled Lead Sheet over 600mm wide should have an underlay fitted.
- Smaller widths may require an underlay depending on the application.
- Standard Underlay should be laid in adjacent sheets, either abutted or overlapped, across the fall of the roof.
- Must be fitted over the whole substrate area.
- Avoid forming hot joints above Standard Underlay.

### Dimensions:

- Available in 25m x 1.0m rolls.

A Product Data Sheet is available from our website [www.britishlead.co.uk](http://www.britishlead.co.uk).



## WOOD ROLL

BLM Wood Roll is used to provide an aesthetically pleasing expansion joint between two separate sheets of Lead. The Sheets are formed around the Wood Roll in a cloak design to provide a weathertight joint without restricting their movement. The clever use of Wood Roll joints can provide the focal point of a roof or building.

Wood Roll is often used when fitting Lead in gutters, cladding and flat or pitched roofing applications as well as at hip and ridge intersections.

BLM King Roll has a larger profile than Wood Roll and is used to form larger hip and ridge joints.

BLM Wood Roll & King Roll are manufactured using treated soft wood timber that has been impregnated with wood preservatives consisting of fungicides, insecticides and water repellent.

- Forms aesthetically pleasing joints on flat or pitched Lead roofs and Lead cladding.
- Each length is undercut at the base to help form a joint that will resist wind-lift.
- Wood Roll should be fitted over Building Paper and Standard Underlay.

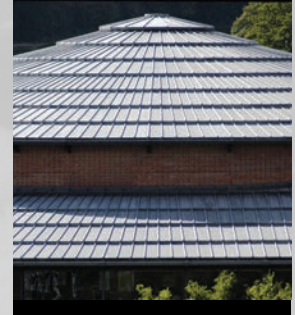

### Dimensions:

BLM Wood Roll:

- 1200mm lengths x 45mm diameter.
- 2400mm lengths x 45mm diameter.

BLM King Roll:

- 1200mm lengths x 75mm diameter.

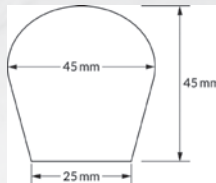
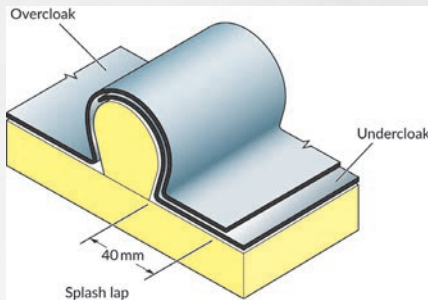

A Product Data Sheet is available from our website [www.britishlead.co.uk](http://www.britishlead.co.uk).

## LEAD T-PREN EXPANSION JOINTS

A large number of buildings in the UK incorporate Lead lined parapet or box gutters. The correct design for a Lead lined gutter incorporates drips and falls (steps) to direct water from its highest point to the outlet.

In many buildings the construction detail of the gutter may not be sufficient to accommodate the number of drips required, or the necessary restructuring of the gutter, to prevent the oversizing of the Lead Sheet bays.

BLM Lead T-Pren provides a quick and cost effective solution to this problem where its use as an expansion joint allows the Lead to be laid along the slope of the gutter.

Lead T-Pren is manufactured by bonding two strips of Code 5 Rolled Lead Sheet to the neoprene centre section. The Lead is effectively sandwiched into the neoprene providing a strong double bond.

T-Pren sections are cut to size and laid across the width of the gutter. The adjacent Lead sheets are welded to the Lead strips in the T-Pren to form a continuous gutter lining. The neoprene section allows for thermal movement.

In addition to Standard Lead T-Pren, Lead T-Pren Plus incorporates a protective Lead cover strip over the neoprene section which protects against UV rays and foot traffic damage, extending the life of the joint. Lead T-Pren Plus also provides a uniform Lead appearance where the gutter lining may be visible.

- Overcomes the problem of laying Lead-lined gutters.
- Allows for thermal expansion.
- Manufactured from Code 5 Rolled Lead Sheet to BS EN 12588.
- Double bonded for extra strength.
- Lead T-Pren Plus protects against UV rays and foot traffic damage and provides a uniform appearance.
- Proven reliability with over 35 years of use with no recorded failure.
- 10 year guarantee.





### Application:

- Always use the recommended underlay.
- Lead T-Pren joints should be fixed at maximum 2m centres.
- Ensure that Lead T-Pren joints are fitted no further than 1 metre from either side of outlets and changes in direction.
- A double weld should be sufficient when lap welding to Code 6.

### Dimensions:

- Standard Lead T-Pren: 3m x 385mm roll.
- Lead T-Pren Plus: 1.5m x 385mm roll.

Lead T-Pren

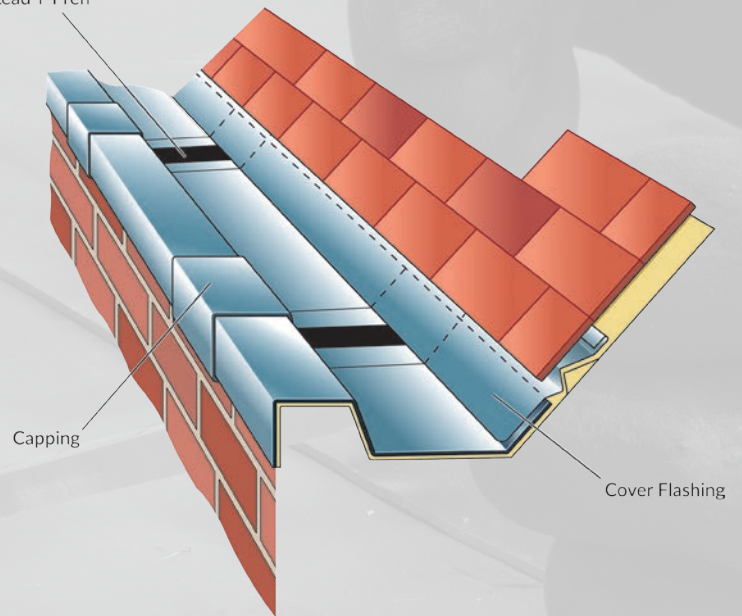

Capping

Cover Flashing

Product Data Sheets are available from our website [www.britishlead.co.uk](http://www.britishlead.co.uk).

## LEAD FIXINGS

The BLM product range includes a range of fixings designed for use with Lead Sheet.

### PERMASTRIP AND COPPER STRIP

Permastrip and Copper Strip are used as fixing clips to prevent the lifting of the free edges of Lead flashings in high wind conditions. They should be used to secure cladding panels at both horizontal and vertical edges of bays. Permastrip and Copper Strip should be cut to length to form clips that suit the application.

#### Application:

- Clips should be fixed to the substrate as near to the clipped edge of the Lead Sheet as possible.
- Clips may be cut with tin snips and crimped round the Lead Sheet with seaming pliers.
- Allow for 6mm of expansion of the sheet when fixing the clips.
- Copper Nails should be used to fix the clips.

#### Dimensions:

- Permastrip - Coil length 20m, width 50mm, thickness 0.5mm.
- Copper Strip - Coil length 20m, width 50mm, thickness 0.6mm.



### COPPER NAILS

BLM Copper Nails are 25mm annular ring shank copper clout nails.

Recommended for fixing Lead Sheet to a substrate.

- Lead Sheet should be fixed in accordance with BS 6915.
- Over fixing can cause premature failure (see page 8).

#### Packaging:

- Available in 1 kg boxes.



Product Data Sheets are available from our website [www.britishlead.co.uk](http://www.britishlead.co.uk)



## LEAD DOT SETS

Several types of intermediate fixings are available for Lead Sheet applications but none are more decorative than Lead Dot Sets. The Lead Dot Set is mainly used to fix vertical cladding.

Care must be taken to ensure fixings are fitted correctly and do not restrict the thermal movement of the Lead Sheet.

## Packaging:

Available in packs containing 20 sets. Each set comprises: Lead Dome; Brass Cup Washer; Nylon Washer and 25mm Stainless Steel Screw.



The table below highlights the appropriate application which every ancillary product is designed for.

## ANCILLARY PRODUCTS BY APPLICATION

	Soakers & Flashings	Gutter Linings	Cladding	Weatherings	Dormers	Roofing
Patination Oil	✓	X	✓	✓	✓	✓
Lead-Cote	✓	X	✓	✓	✓	✓
Hall Clips	✓	X	X	X	X	X
Lead Pointing Sealant	✓	X	X	X	X	X
Lead Slates	X	X	X	X	X	X
Building Paper	X	✓	✓	✓	✓	✓
Standard Underlay	X	✓	✓	X	✓	✓
Wood Roll	X	✓	✓	X	✓	✓
T-Pren	X	✓	X	X	X	X
Aluminium Soakers	✓	X	X	X	X	X
Fixing Strips	✓	X	✓	✓	✓	✓
Copper Nails	X *	✓	✓	X	✓	✓
Lead Dot Set	X	X	✓	X	✓	X

\*Copper Nails should be used to fix hip and ridge flashings.

# BLM GET LEAD! APP

BLM Get Lead! App is the ultimate tool for roofing contractors and leadworkers involved in the installation of Lead Sheet in a variety of roofing applications offering a one stop solution for users of Rolled Lead Sheet.

The app has many powerful features including full product information, installation guides with exclusive video content, weight and roof pitch calculators as well as a stockist locator, enabling users to search for their nearest BLM British Lead supplier by current location or postcode.

The app is available free of charge for both Apple and Android devices



## Powerful tools to help get the job done.

### Find local stockists

Working outside your usual area or need an emergency purchase?

### Full product information

Understand our range of products and identify the right product for the job

### Fitting Guides

For those in need of a reference point in installing lead sheet

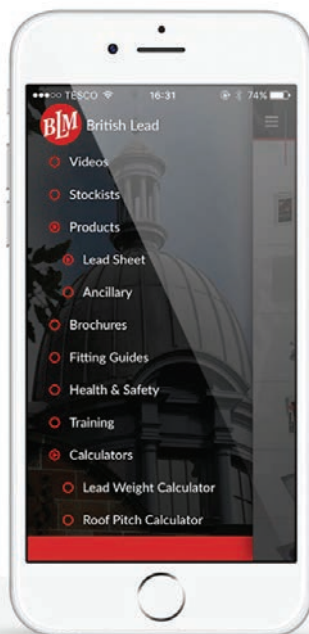

### Video

Step by step guides for your lead fitting needs in a range of common or unfamiliar applications

### Lead Weight Calculator

Easy to use piece weight calculator to help end users price work

### Roof Pitch Calculator

Easy to use calculator to measure pitch roof and minimum lap

## ROOFING TOOLS

BLM Roofing Tools is a unique collaboration between BLM British Lead and Monument Tools, one of the biggest names in the manufacture and distribution of roofing tools throughout the world.

Both companies have worked together to create a brand that replicates their respective traditions and core values, to bring you the best British made specialist Leadwork and Roofing tools. They share a rich history and heritage in their industries dating back over 85 and 130 years respectively, and aim to build on existing strong reputations for product quality, outstanding service, knowledge and expertise.



## Roofing Tools

BLM Roofing Tools offer a comprehensive range of high quality leadwork and roofing tools including lead dressers, shaping sticks, bossing mallets, chase wedges and many more. The range of tools caters for all construction professionals whether they are installing occasional flashings right through to complex Leadwork detail.

All BLM Roofing Tools products are made in Britain and come with a lifetime material defects warranty.



For more information on BLM Roofing Tools products, please email us at [info@blmroofingtools.co.uk](mailto:info@blmroofingtools.co.uk) or visit [www.blmroofingtools.co.uk](http://www.blmroofingtools.co.uk)

## HALLHOOK

Bought to you by the makers of Hall Clip; the Hallhook is a permanent, hidden and secure device for use when replacing broken slate.

Hallhooks provide a more superior and robust fixing than metal strips, plastic or silicone, which are either unsightly or unlikely to last the test of time. Hallhooks are quick and simple to use saving time when repairing broken slate.

- For general repair
- After solar panel bracket mounting
- After roof light/window installation
- After installing slate vents



Hallhook installation video is available at [www.britishlead.co.uk/hallhook-replacing-broken-slate#video](http://www.britishlead.co.uk/hallhook-replacing-broken-slate#video)

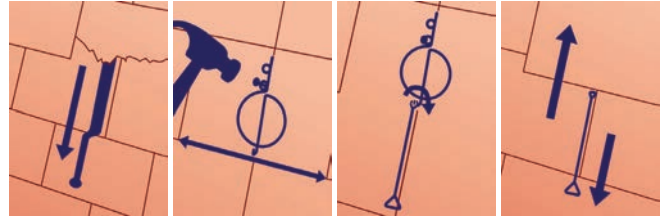

### Installation:

1. Remove broken slate.
2. Position the Hallhook between slates so the bottom hook is 10mm above finished slate baseline & fix with a nail.
3. Hang accompanying hook pull on hook.
4. Slide new slate into place. Gently pull the hook pull until the Hallhook holds the base of the slate. Remove hook pull. Do not over stretch.

### Packaging:

- Available in packs containing 10 Hallhooks and 1 Hookpull



A Product Data Sheet is available from our website [www.britishlead.co.uk](http://www.britishlead.co.uk).

## SITE WIPES

### For use with Lead

Working with Lead can leave microscopic traces of metal on your hands even if you have been wearing gloves. These particles must be removed before eating, drinking, smoking or even using a mobile device to ensure Lead is not ingested. This is not always easy on a roof or on site with no access to soap and running water.

BLM Site Wipes are effective at reducing lead particles from hands and surfaces, ensuring best possible safety on site when soap and water are not immediately available.

Site Wipes can also be used in combination with soap and water to provide a more robust cleaning routine. Always use soap and water wherever possible and at the first opportunity.

### For general use

BLM Site Wipes are specially formulated with an additional grime remove for use as a general purpose, water-free, cleaning wipe for hands and tools. Removes grease, lubricants, adhesives, oils, tar, asphalt, inks, wax, non-cured PUR (gum) foam and many other difficult to remove soils such as coal dust & graphite.

- Ideal for use on site without access to soap and water
- Convenient for use on the move
- Formulated with additional grime remover
- Suitable for tools and surfaces
- Dermatologically tested

### Packaging and dimensions:

- Available in packs containing 20 wipe each
- Wipe size: 200mm x 180mm



A Product Data Sheet and H&S Data Sheet are available from our website [www.britishlead.co.uk](http://www.britishlead.co.uk).

# HEALTH & SAFETY

As a responsible Lead manufacturer, we want to ensure our customers are fully aware of our recommended storage, handling and safety tips to assist in minimising any potential Health and Safety risks.

## Storage Tips:

Lead is a dense, but soft metal. It can be easily damaged when stored incorrectly. The following storage tips can assist in keeping Lead in excellent condition.

- All rolls of Lead should be stored in a clean dry area on a sealed concrete floor or raised off the floor on a strong timber base.
- Contact with moisture in roll format can result in the formation of red oxide staining, similar to rust, in the roll layers in a matter of hours. This may be cleaned, prior to fitting, with a nylon scourer and a 5% nitric acid solution, but best avoided in the first instance.
- Where possible, smaller flashing rolls with a width of 450mm or less should be stood on their roll ends and wider rolls should be laid down on pallets to minimise the risk of accidents or damage.
- Always remember that the Lead surface could be scored or damaged if it comes into contact with rough surfaces and sharp objects, creating thin/weak spots in the sheet.

## Handling and Recovery Tips:

Due to the density of the material, even the smallest Lead rolls are unusually heavy and completely disproportionate to their size. The following handling tips can assist you when lifting and moving Lead rolls.

- Never attempt to lift a roll of Lead on your own unless you are absolutely confident of your own ability to handle it without undue effort.
- If in doubt, either insert a strong steel bar through the roll and lift with the help of another person or employ approved mechanical handling equipment.
- Always wear work gloves when handling Lead to protect your hands from both Lead dust particles and sharp edges.
- Scrap Lead Sheet recovered from demolition or construction sites must only be sent to approved scrap merchants or directly to BLM through our Scrap Back scheme, terms and conditions apply (see page 43).
- Scrap Lead should not be transported in open vehicles, the same should be carefully cleaned after use.



Wear gloves



Lift with care - seek assistance

## Safety Tips:

Lead in its metallic state does not present a health risk provided that a few simple precautions are followed:

- Wear appropriate personal protection equipment, such as safety gloves and boots.
  - Always wash your hands and forearms as soon as you finish handling Lead and before you do anything else. This applies even when wearing gloves.
  - Always use BLM Site Wipes when access to soap and water is not available.
  - Do not eat, drink or smoke after handling Lead until you have washed your hands.
- When welding Lead follow Health & Safety guidelines and wear eye protection and a disposable mask.
  - When sweeping a Lead storage area, wear a protective dust mask and damp down any dust before you sweep.

Health & Safety Data Sheets for specific BLM products are available at [www.britishlead.co.uk](http://www.britishlead.co.uk) providing you with full product safety information.



Scrub hands



Don't bite finger-nails



Wear mask when welding



Leave work wear on-site

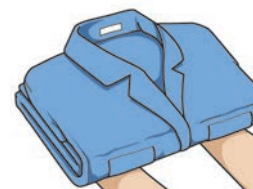

Wash separately



Do not eat, drink or smoke after handling Lead until you have washed your hands



Wear mask when stripping old Lead



Regular blood tests

# BASIC FITTING GUIDES

## Cleaning Joints

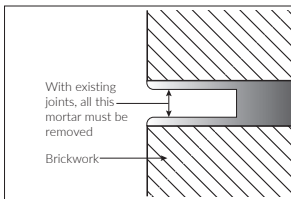

When removing mortar from an existing joint it is important to remove ALL the mortar to a depth of at least 25mm.

## Joints Between 6mm-26mm Wide

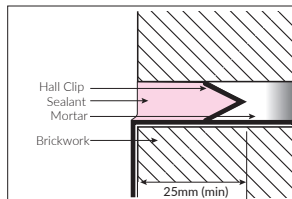

The joint should be at least 6mm wide to allow Hall Clips to be inserted to hold the Lead flashing in place before pointing in with BLM Lead Pointing Sealant.

## Joints Over 18mm Wide

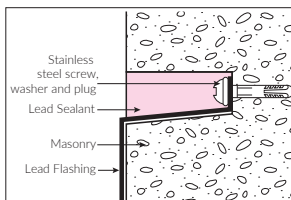

Wide joints over 18mm will require a more substantial fixing. Hall Clip Plus can be used for chase heights of 18-26mm. Alternatively, it is recommended that stainless steel screws and washers are used at 450mm centres on flashing lengths of no longer than 1500mm. The joint should be pre-pointed with mortar and then pointed with BLM Lead Pointing Sealant.

Joints over 20mm wide should comprise half mortar and half BLM Lead Pointing Sealant, the nozzle should be cut at an angle and the sealant applied to both the top and bottom of the joint once the mortar at the rear of the joint has set.

## Joints With A DPC

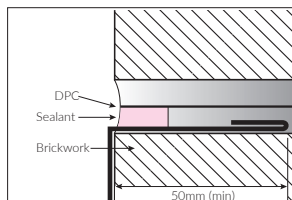

Joints below a DPC can often cause problems if they are not fitted correctly. On new buildings the Flashing can be inserted during construction, using a single welt to hold it in position. A batten, the same height as the joint and 25mm wide may be used to support the DPC until the mortar has set. The batten is then removed leaving a clean void for pointing with BLM Lead Pointing Sealant. On existing buildings it is often better to chase out a joint at least 600mm below the DPC, this will avoid any potential damage to the damp proof membrane by disturbing the brickwork or masonry above it.

## Helpful Tips

- Always ensure joints are thoroughly cleaned and no mortar remains
- Individual flashing lengths should not exceed 1500mm
- Joints under 26mm wide should be held firmly in place with Hall Clips Standard or Hall Clips Plus
- Using Hall Clips instead of Lead wedges will help to prevent the easy theft of Lead flashings
- Use at Least 1 Hall Clip per step when fitting step flashings
- Use 1 Hall Clip at 450mm centres and where flashing pieces overlap when fitting linear flashings
- Joints over 18mm wide can also be secured with stainless steel screws and washers
- Use BLM Lead Pointing Sealant to point in the Lead in to the masonry
- Ensure joint is completely dry before applying the sealant
- Cut the Sealant nozzle to suit the width of the joint
- Minimum depth of the sealant should be no less than 10mm
- The face of the sealant can be smoothed using a wet pointing tool

Technical drawings produced with permission from the Lead Sheet Training Academy.



## Fixing free edges of flashings

### A. Clips for flashings over interlocking tiles

All flashings should be secured against the risk of wind lift. Position fixing clips at between 300-500mm centres depending upon the degree of exposure to wind.

Clips should be made from quarter hard copper, at least 0.6mm thick or stainless steel at least 0.38mm thick. Turn the clips over by at least 25mm. Allow for 6mm expansion of the lead in to the clip.

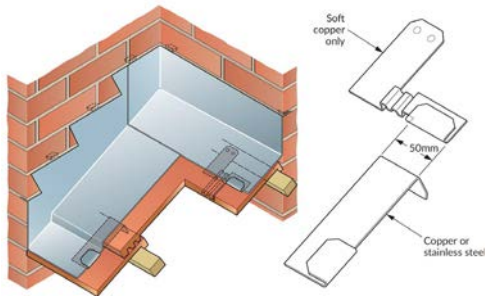

### B. Clip to ridge or hip roll

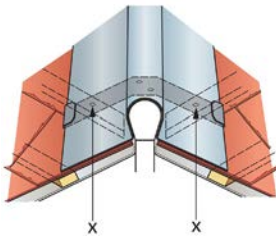

### C. Clip to apron flashings

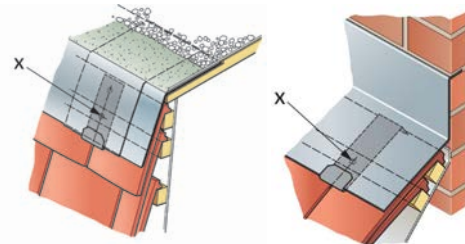

x = For moderate to severe exposures additional fixings should be positioned at not more than 75mm from the free edge. Secure clips with Copper Nails.

## Step and cover flashings and secret gutters

### A. Step and cover flashing to profiled tiles

Note:  
No flashing piece to exceed 1.5m length.

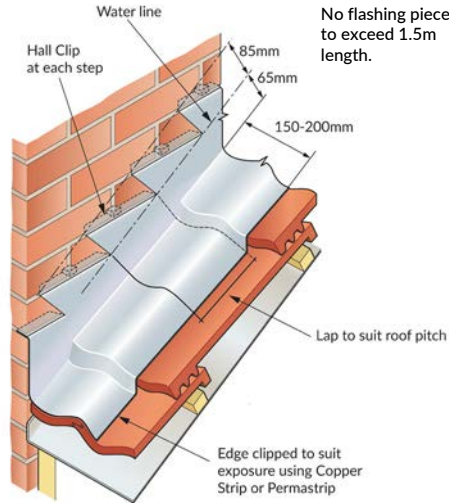

### B. Abutment step and cover flashing with secret gutter

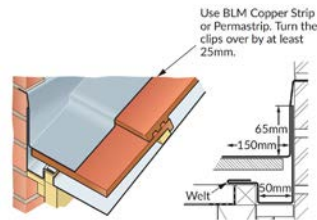

### C. Abutment flashing with secret gutter

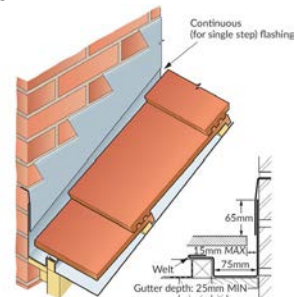

## Soakers and step flashings

### A. Soakers

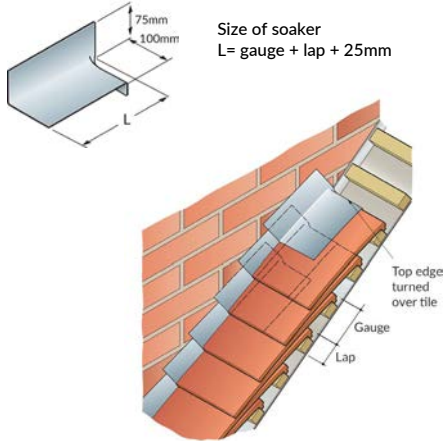

### B. Marking - out step flashing

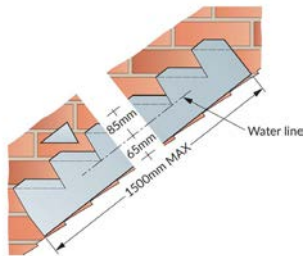

Note: No flashing piece to exceed 1.5m in length.

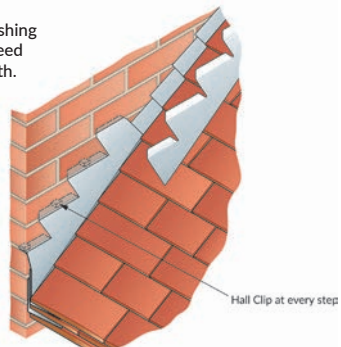

## Cover flashing to felt roof upstand

### A. Soakers

Note: No flashing piece to exceed 1.5m in length.

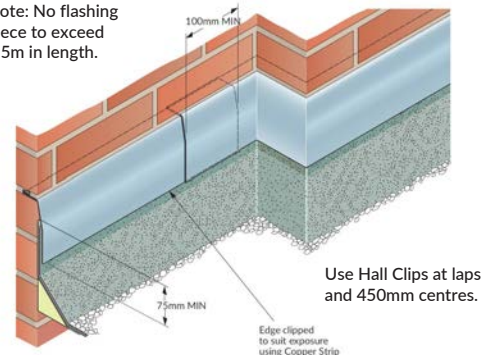

### B. Cover flashing to asphalt upstand

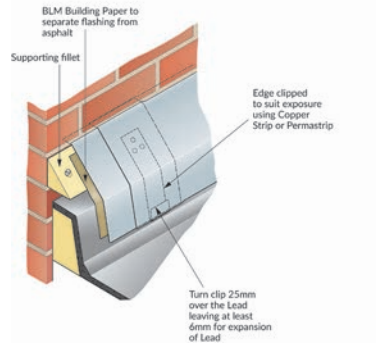

### C. Cover flashings, roof pitches up to 3°

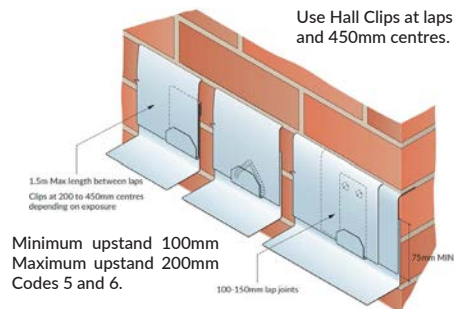

## Chimney flashings

### A. Bossed apron

Edge clipped to suit exposure using Copper Strip or Permastrip.

Use Hall Clips at 450mm centres.

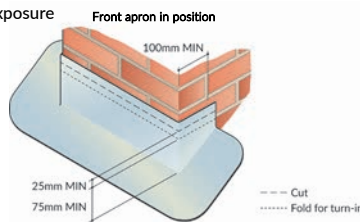

### B. Welded apron

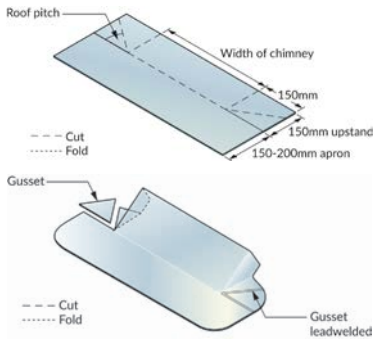

### C. Side flashing

Varies to suit type of slate or tile.

Mark the steps out to suit the joints in brickwork.

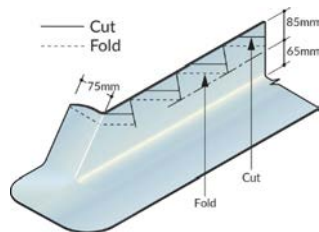

### D. Bossed back gutter

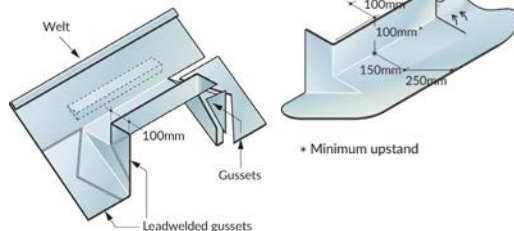

### E. Welded back gutter

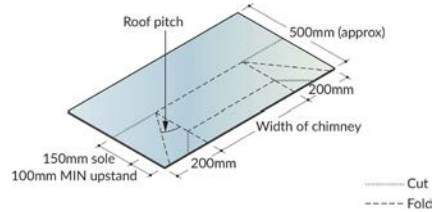

### F. Back gutter fixed

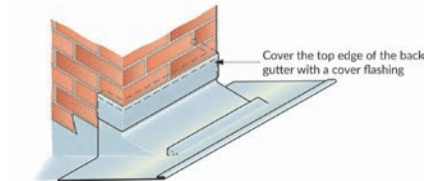

Use Hall Clips at 450mm centres.  
Minimum 3 Hall Clips.

## Apron flashings

### A. Apron flashing over slates or tiles

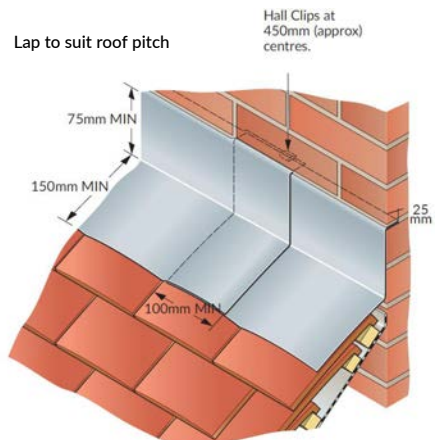

Edges clipped to suit exposure. Use Copper strip or Permastrip.  
No flashing piece to exceed 1.5m in length.

## Ridge saddles

### A. Ridge saddle at abutment (bossed)

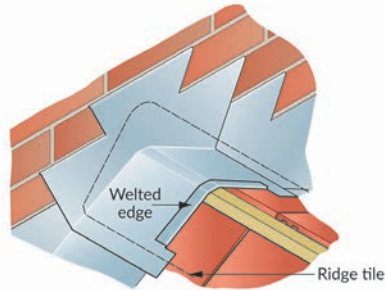

### B. Ridge saddle at abutment (lead-welded)

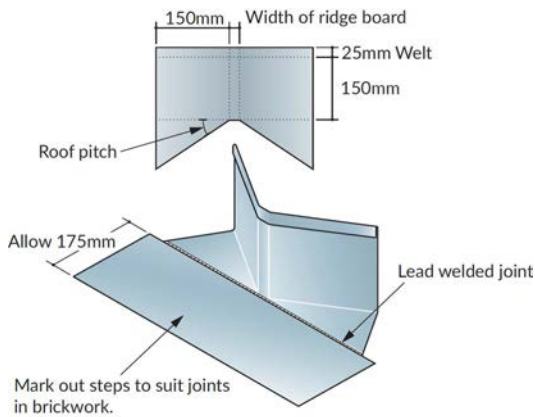

### C. Ridge saddle at the top of a valley

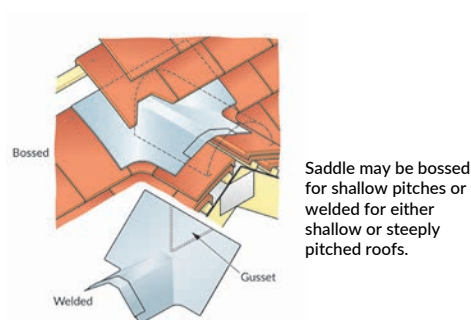

## Ridge and hip flashings

### A. Cross section

No ridge flashing to exceed 1.5m in length for Code 4 and 2m in length for Codes 5, 6, 7, and 8.

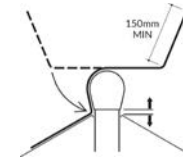

\* Roll fixed 5mm (MIN) above slate line

### B. Ridge flashing

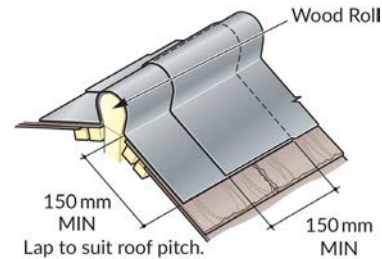

Free edges clipped to suit exposure using Copper Strip or Permastrip.

### C. Ridge and hip intersection

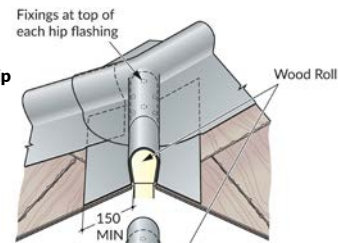

### D. Hip flashing

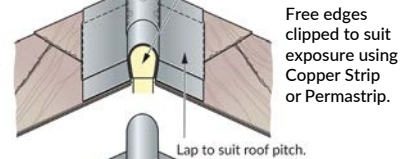

### E. Hip flashing roll end

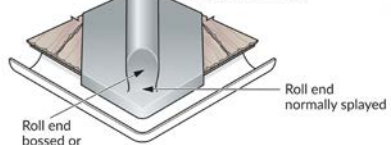

## Pitched valleys

### A. Details

Felt omitted for clarity

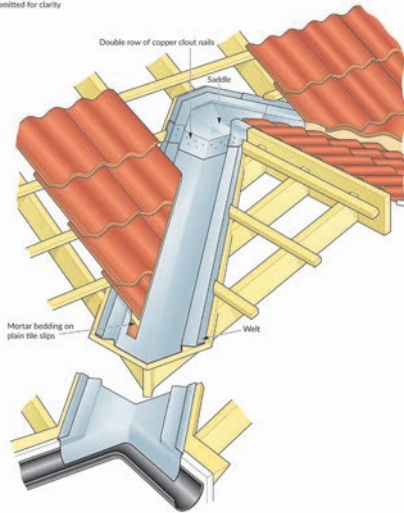

Additional head fixings for pitches above 60° - in top third of each side only.

Note: No flashing piece to exceed 1.5m in length.

### B. Cross section

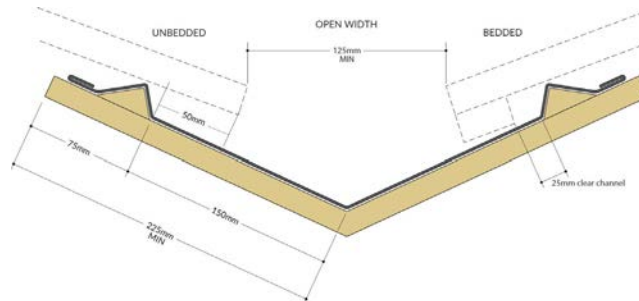

Open Width (mm)	With bedded tiles Width of Lead to line valley (mm approx)	With unbedded tiles or slates Width of Lead to line valley (mm approx)
100	500	400
125	525	425
150	550	450
200	600	500
250	650	550

For information on the sizes of pitched valleys in relation to catchment area, it is essential to refer to Rolled Lead Sheet The Complete Manual published by the LSTA.

## Drips and rolls

**A. Drip (up to 3°)**

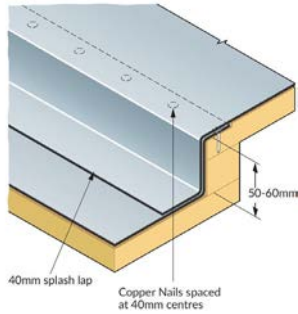

**B. Drip (over 3°)**

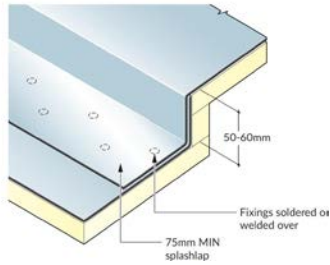

**C. Box gutter drip without splash laps**

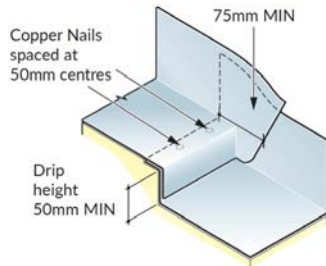

**D. Tapered gutter drip without splash laps**

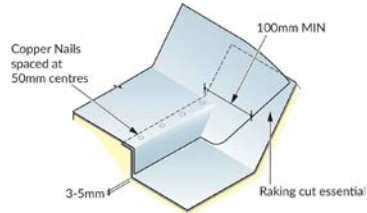

**E. Standard wood cored roll with splash lap**

Cross section of wood cored roll joint

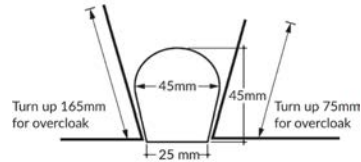

**F. Standard wood cored roll with splash lap**

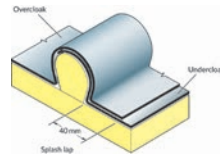

Wood cored roll joints are suitable for all roofing and cladding applications.

Nail the roll undercloak at the top third of the length only using Copper Nails at 50mm centres.

**G. Roll drip intersections for wide gutters**

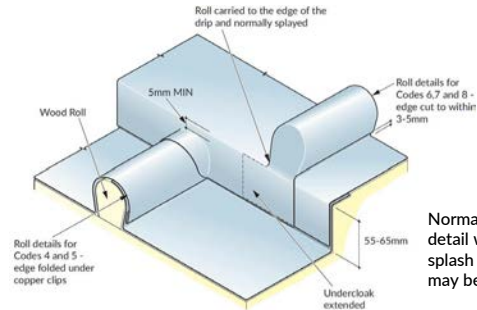

Normal roll detail with splash lap may be used.

**Table 1**

Gutter drip heights	
BS EN 12588 Code No	Minimum drip height (mm)
4, 5 and 6	50 where there is no roll to drip intersection
4	55
5	55
6	55
7	60
8	60

## Parapet and tapered gutters

### A. Cross section of parapet gutters

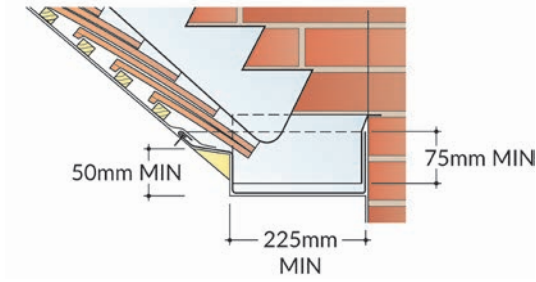

### B. Cross section of box gutter

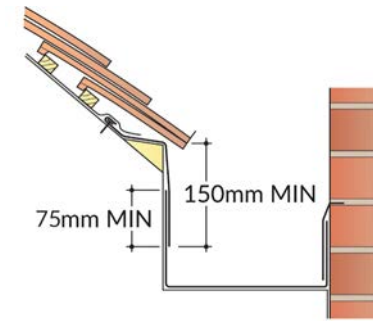

For details of maximum sizes, see table 2.

### C. Measurement of girth

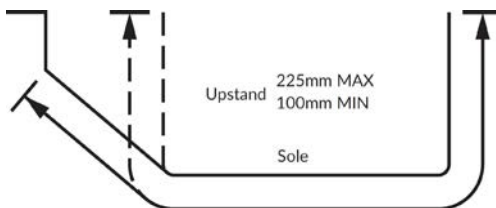
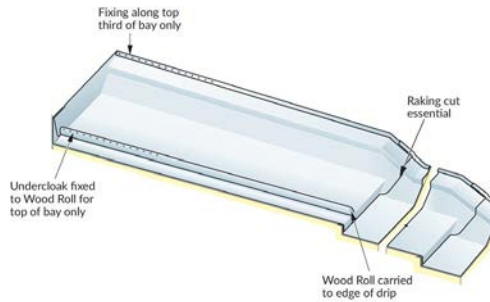

Table 2

Gutter dimensions		
BS EN 12588 Code No	Maximum length between drips (mm)	Maximum overall girth (mm)
4	1500	750
5	2000	800
6	2250	850
7	2500	900
8	3000	1000

### D. Tapered gutter details



### E. Cross section of tapered gutter

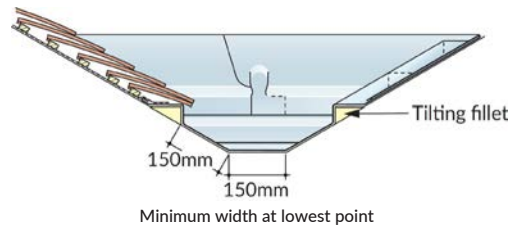

# TECHNICAL SUPPORT & TRAINING

## BLM Technical Support

Here at BLM, we are committed to provide a top class technical service to those using Lead Sheet in the construction industry.

In addition to providing free basic technical advice by phone and email, we also offer 5 levels of support ranging from more in depth technical advice and comments against photographs provided by email or in a written report, site visits with verbal comments or written report through to bespoke consultancy packages tailored to your requirements.



The correct specification and installation methods for Rolled Lead Sheet are set out in the Rolled Lead Sheet Manual, available from the Lead Sheet Training Academy (LSTA), the forefront of training for those using lead in the construction industry.

These are under constant revision to ensure best practise and maximum performance are achieved when installing Lead Sheet.

For your convenience we produced a range of Basic Fitting Guides that cover some of the more common Lead Sheet applications. Product and application video guides are also available to assist users by providing a reference point when fitting lead.

All guides can be accessed from our website [www.britishlead.co.uk](http://www.britishlead.co.uk) and BLM Get Lead! app, available for both Apple and Android devices.

For more information on the level of support you require or for further advice on working with Lead in construction, please contact our technical team on 0330 333 3535 or email [technical@britishlead.co.uk](mailto:technical@britishlead.co.uk).





### **Lead Sheet Training Academy (LSTA)**

The Lead Sheet Training Academy is at the forefront of training for those using lead in the construction industry. The academy offers a full range of training courses specifically designed to meet the needs of installers and employers.

The LSTA operates from a state of the art, purpose-built training facility in East Peckham. The training centre includes full scale training rigs and resources as well as providing a well-equipped environment in which to learn as it re-creates real-life situations.

**LSTA**  
Lead Sheet Training  
Academy

The centre is recognised as a CITB Approved Training Organisation. The tutors are fully qualified with experience of working on-site and are CITB-approved assessors.

The LSTA currently offer City & Guilds accredited programmes and Specialist Applied-skills Programmes (SAP), for which they are the sole provider. Specialist Upskilling Programmes (SUP) and On-Site Assessment and Training (OSAT) as well as bespoke training packages are also available.

For help choosing the right course, information on fees and grants, course dates and to book your place on your chosen course, please contact the LSTA on 01622 872432 or email [info@leadsheet.co.uk](mailto:info@leadsheet.co.uk)





British Lead

# SCRAP BACK

**BLM's Scrap Back scheme offers contractors buying regularly from BLM supplied merchants the chance to return their scrap Lead at preferential rates, further underlining our commitment to recycling and sustainability.**

- Contractors can now return their scrap Lead direct to BLM
- Open to contractors regularly buying Lead from BLM supplied outlets
- Collection service available with mechanical loading
- Payment direct to the contractor
- Terms & Conditions apply



100% recycled

# PRODUCT GUIDE

For more information on our products, please contact our sales team on 0800 117 882, email us on [sales@britishlead.co.uk](mailto:sales@britishlead.co.uk) or visit [www.britishlead.co.uk](http://www.britishlead.co.uk).

For technical support and further advice on working with Lead in construction, please contact our technical team on 0330 333 3535 or email [technical@britishlead.co.uk](mailto:technical@britishlead.co.uk).



British Lead

Freephone: **0800 117 882**

Freefax: **0800 575 092**

**[www.britishlead.co.uk](http://www.britishlead.co.uk)**

Pear tree Lane, Welwyn Garden City,  
Hertfordshire AL7 3UB

MEMBER OF  
**ECOBAT**  
TECHNOLOGIES

