

Key Benefits

Chilled mirror hygrometers are used in standards and metrology labs as well as in industrial applications where precise and repeatable humidity measurement and control are required. The inherent accuracy and long term stability provide many advantages over other types of humidity measurement technologies.

- Compact and rugged design for easy installation and durability
- Built-in data logger provides ability to record historical data
- Sensor conveniently plugs into wall mount chassis for facility monitoring, eliminating the need to run cable
- Sensors may be connected up to 91 m away via cable for remote monitoring
- Displays and transmits in a variety of parameters, such as dew point, relative humidity, dry bulb, wet bulb, absolute humidity, volume ratio, and mass ratio, offering flexibility during operation
- Digital (RS-232) interface for data integrity
- Patented PACER® cycle automatically cleans mirror to ensure measurement integrity
- PanaView™ software transfers data from the meter to a PC for additional storage and enables data to be viewed graphically
- Easy to configure using the front panel for simple operation
- Humidity measurements are traceable to National Institute of Standards and Traceability (NIST)

Applications

- Environmental test chambers
- Engine test cells
- Clean rooms
- Air conditioning and heat exchange coil testing
- Metrology labs

OptiSonde™

General Eastern Chilled Mirror Hygrometer

General Eastern Instruments has joined other GE high-technology sensing businesses under a new name—GE Sensing.



GE Sensing

The OptiSonde chilled mirror hygrometer is a National Institute of Standards and Technology (NIST) traceable humidity transfer standard at an exceptional value. The compact rugged analyzer is connected to either a single- or two-stage chilled mirror sensor and PRTD. Chilled mirrors are the humidity sensors of choice when laboratory and process measurements require high precision without long-term drift. An LCD indicates two simultaneous user-configured parameters. OptiSonde provides two user-configured analog (4 to 20 mA) outputs. The display and front panel keys enable quick and easy configuration.

The OptiSonde easily records humidity and temperature data from a wide variety of applications. The analyzer is equipped with a data logger capable of recording for 100 days at a sample rate of 1 second and is equipped with an internal real-time clock. The saved data is uploaded to a PC using terminal software as ASCII delimited text, enabling it to be opened by Excel® and other spreadsheet programs for data reduction, graphing and statistical analysis.

Theory of Operation

Chilled mirrors fundamentally measure the dew or frost point temperature by controlling a reflective surface to an equilibrium temperature between dew/frost formation and evaporation and precisely measuring the temperature of the mirror at this point.

GE's chilled mirrors consist of a small polished hexagonal rhodium, or platinum mirror attached to a thermoelectric cooling module (TEC). OptiSonde's servo controller applies current to the TEC, which causes the mirror to cool. The mirror is illuminated with a regulated Gallium Arsenide (GaAs) emitter that transmits light in the infrared spectrum. The light reflected by the mirror is received by a photo detector. When water vapor condenses on the mirror as water or frost (ice crystals), the light received by the photodetector is reduced due to scattering. This results in the servo controller reducing the power, causing the mirror to slightly warm.

OptiSonde's control system will modulate the amount of current flowing through the TEC to maintain a temperature where the rate of condensation and evaporation of water molecules and the mass of water on the mirror are constant. The resulting temperature of the mirror is then, by definition, equal to the dew or frost point temperature. A precision four-wire platinum RTD imbedded in the mirror measures the temperature. The accuracy of the dew point measurement has been validated to an accuracy of $\pm 0.2^\circ\text{C}$ dew/frost point. Dry bulb temperature is measured with a precise four-wire 100Ω platinum RTD. The dew/frost point and dry bulb RTD resistance signals are conditioned and amplified by OptiSonde's monitor to display and transmit dew/frost point and temperature.

The cardinal measurements of dew/frost point and dry bulb temperature, along with pressure and molecular weight constants, are used to calculate other humidity parameters, such as relative humidity, wet bulb, ppm_v, ppm_w, absolute humidity, and water vapor pressure values using psychrometric equations.

The RTD sensor, which is imbedded in the chilled mirror, never comes in contact with the process or test environment. The wetted parts consist of the platinum or rhodium mirror, Mylar® or stainless steel vapor barrier and epoxy sealant. The net result is drift free humidity measurement designed to maintain accuracy specifications for many years.

Chilled mirrors require a nominal flow rate across the mirror to achieve the optimal dew/frost formation and response time. The sensor should either be installed in a duct with moving air or be equipped with a sampling pump. The optimum flow rate is 0.5 to 2.5 SCFH (0.25 to 1.2 L/min). GE provides sampling systems to condition the temperature, regulate the pressure and filter process air before reaching the chilled mirror. Our applications engineers would be pleased to discuss your application in detail and provide a recommendation for the system best suited to your needs.

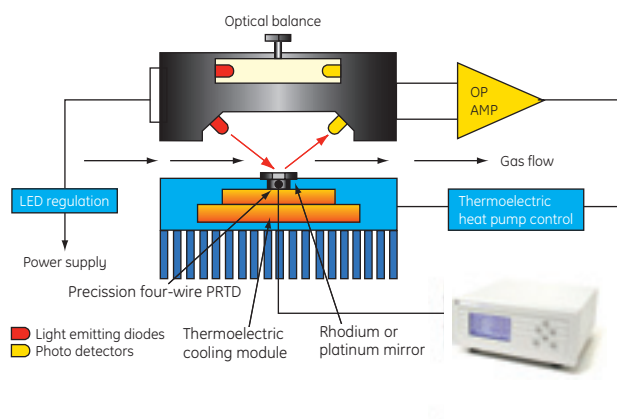

Contamination Control and Self-Cleaning Mirrors

For environments where physical contaminants such as dust, oil mist and pollen are present, the use of a sampling system with a filter media is recommended. The filter media must be hydrophobic so as to not absorb or release water vapor into the test stream. Over time the mirror can be etched or pitted by particulates that lead to altering the light scattering characteristics. GE's mirrors are field replaceable. The standard rhodium mirror may be upgraded to platinum for industrial applications. The two stage sensors also utilize stainless steel wetted surfaces.

GE developed a patented contamination compensation scheme called PACER (Program Automatic Error Reduction). The PACER cycle may be initiated manually or by programming a timed cycle. The cycle starts by capturing the data (during the PACER cycle a constant reading can be transmitted via the analog outputs) and cooling the mirror well below the dew point such that a thick dew layer forms on the mirror.

The mirror is then rapidly heated. During the heating a significant amount of soluble and some non-soluble contamination is flash evaporated. The contamination left on the mirror tends to aggregate in "dry islands" or "spots" (much like a glass that comes out of a dishwasher). This process leaves approximately 85% of the mirror clean. The light signal received by the photodetector is compared against a reference LED/photodetector and the two signals are "balanced," effectively negating the effect of the residual contamination left on the mirror.

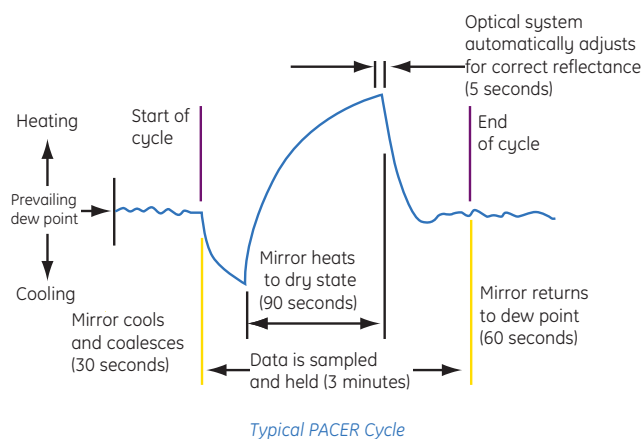
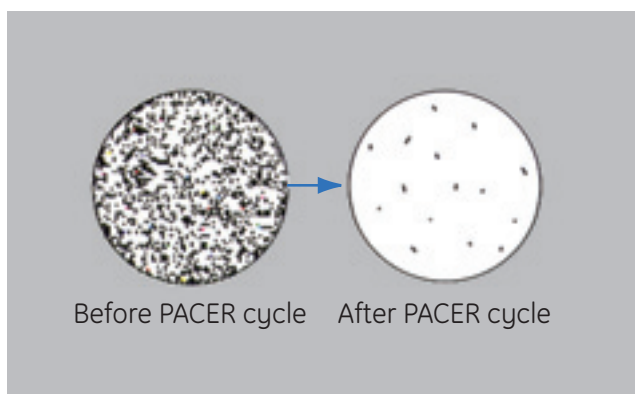

The PACER cycle works very well, but eventually manual cleaning may be required. All of GE's chilled mirrors are accessible for manual cleaning. Cleaning is a simple process consisting of wiping the mirror with a cotton swab wetted with cleaning solution or distilled water.

Calibration Services

Proper calibration is critical to the measurement integrity of your equipment. Comparing and adjusting the output of a device or sensor against a known reference standard ensures accuracy, reliability and repeatability.

We provide a single source for initial start-up, programming and verification and for scheduled calibrations. The requirements of your application dictate the frequency of calibration and we will tailor a multiyear contract to your needs.

We perform on-site calibrations that keep your equipment in your facility—minimizing downtime. This is a good alternative if you have more than one piece of equipment. Mail-in service to our modern calibration facilities provides a more controlled environment and NIST traceability.

OptiSonde Specifications

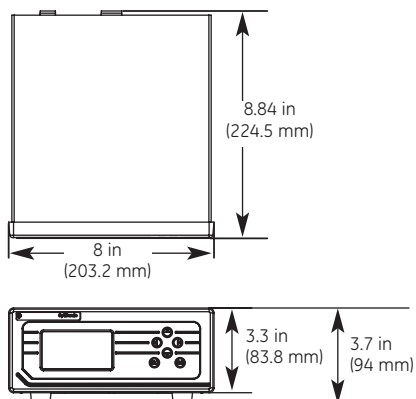

Bench Top

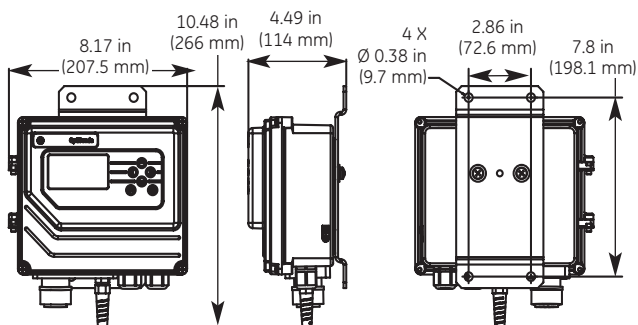

Wall Mount

Power

- 100 - 240 VAC, 50 to 60 Hz, 60 Watts
- 18-32 VDC (bench top only)

Enclosure Material

- Wall mount: Cast aluminum
- Bench top: Aluminum body with plastic front bezel

Dimensions

- Wall mount: 26.6 x 20.8 x 11.4 cm (h x w x d)
- Bench top: 9.4 x 20.3 x 22.4 cm (h x w x d)

Weight

- Wall mount: 2.4 kg
- Bench mount: 1.4 kg

Ingress Protection Rating

- Wall mount: IP-65
- Bench top: IP-20

Front Panel Keys

- Rubber function keys—may be locked out via software

Dew Point Range

Dependent on sensor used

Dew Point Accuracy

± 0.2°C dew/frost point

Dew Point Repeatability

0.1°C

Other Humidity Parameters

The range and accuracy of absolute humidity ($m_{H_2O/v}$) and relative humidity (e/e_{sat}) readings are based on the fundamental dew point and temperature measurements. The range and accuracy of mass (ppm_w) and volume (ppm_v) ratios are calculated based on the fundamental dew point measurement and pressure and gas molecular weight constants.

Temperature Accuracy

±0.15°C

Repeatability

0.05°C

Display

Two simultaneous parameters with 0.01°C resolution. "Dew Layer Thickness," "Control," "Alarm" and "Service" indicators

Analog Output

Two linear simultaneous parameters. 0/4 to 20 mA (isolated) with 250Ω max load

Alarm

Form C (SPDT) 7 amp, 30 VDC (resistive load)

Digital Interface

RS-232

Cooling Slew Rate

1.5°C/sec

Self Cleaning and Balancing

Via patented PACER cycle. PACER may be programmed to run on an elapsed time or daily timer

Operating Temperature

Analyzer: -10°C to 60°C

Data Logger

Capable of recording eight parameters, time and date for a minimum of 100 days at sample rate of one second.

Operating Humidity

0 to 95% RH non-condensing

MTBF

Five years of continuous operation

Certifications

CE Approval

Electrical I/O

Power: AC IEC receptacle for bench top and screw terminal blocks for wall mount. Chilled mirror sensor: keyed connector/cable. Temperature sensor, keyed connector/cable. RS-232: SUB-D-9. Analog Outputs: screw terminals

Carrying Case

Optional hard shell carrying case with die-cut foam for bench top unit and accessories

GE Sensing

1111H Single Stage Chilled Mirror Specifications

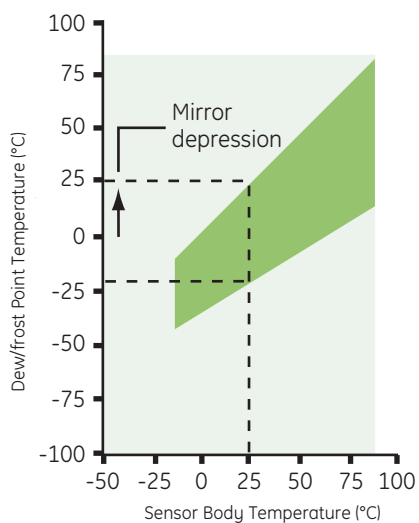
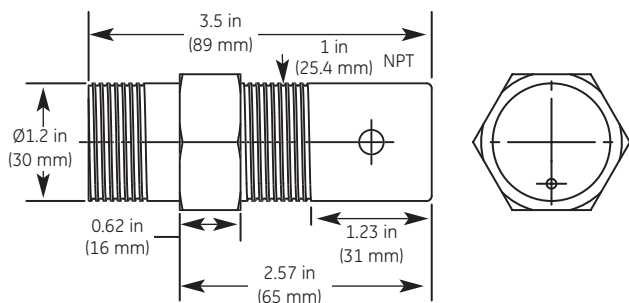

Sensing Element

Four-wire 1/3 Class A DIN 43760 PRT, 100Ω @ 0°C

Dew/Frost Point Accuracy

± 0.2°C

Depression

45°C at 25°C, 1 atmosphere for standard air

Typical Dew Point Measurement Range

-15°C to 25°C Td at 25°C, 1 atmosphere for standard air.
(Equivalent to 6-100% RH)

Sample Flow Rate

0.25 to 1.25 LPM (0.5 to 2.5 SCFH)

Operating Temperature

-15°C to 80°C

Operating Pressure

0.8 to 15 bar (-3 to 200 psig)

Power

Derived from analyzer

Sensor Body

Epoxy-coated aluminum

Filter

PTFE filter optional (standard on 1111H-GE)

Mirror

Rhodium-plated copper (solid platinum optional)

Vapor Barrier

Mylar

Sensor Wetted Material

Epoxy-coated aluminum, rhodium copper, mylar

Electrical Connector

MS style multipin keyed connector

Weight

- 1.4 kg (1111H)
- 1.8 kg (1111H-GE)

Accessories

- MB-11: Wall mounting bracket (1111H)
- PTFE-GE: PTFE filter
- Platinum mirror
- O111D: Pressure boss (flow cell)

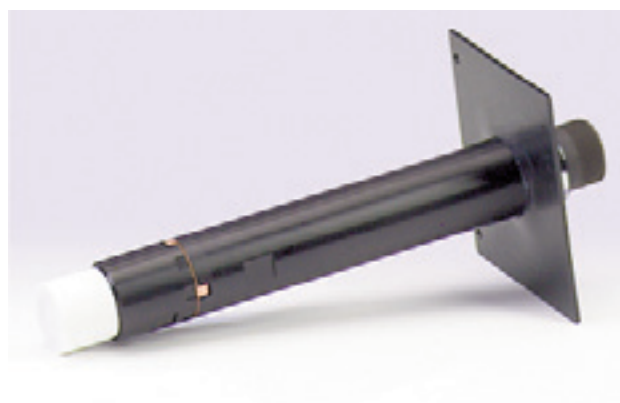

1111 H-GE

D2 Two Stage Chilled Mirror Specifications

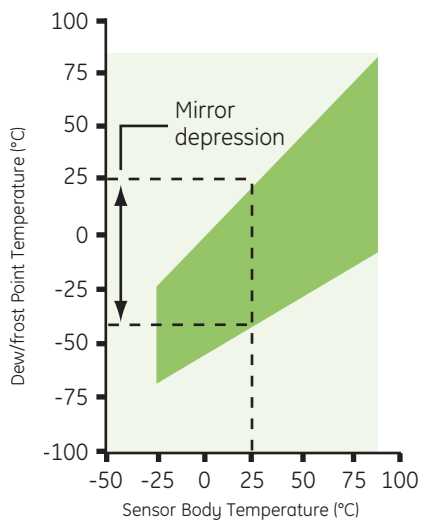
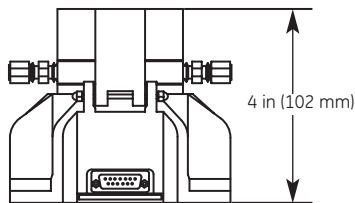
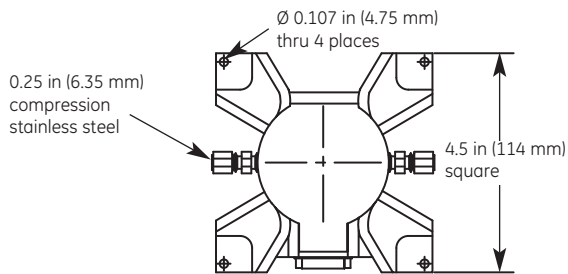

Sensing Element

Four-wire 1/3 Class A DIN 43760 PRT, 100Ω @ 0°C

Dew/Frost Point Accuracy

± 0.2°C

Depression

65°C at 25°C, 1 atmosphere for standard air

Typical Dew Point Measurement Range

-35°C to 25°C Td at 25°C, 1 atmosphere for standard air.
(Equivalent to 1 to 100 % RH)

Sample Flow Rate

0.25 to 1.25 LPM (0.5 to 2.5 SCFH)

Operating Temperature

-25°C to 85°C

Operating Pressure

1 to 11 bar (0 to 150 psig)

Power

Derived from analyzer

View Port

Equipped with illuminated view port that enables observation of mirror

Sensor Body

Cast aluminum with 314 SS flow cell

Mirror

Rhodium-plated copper (solid platinum optional)

Vapor Barrier

Stainless steel

Sensor Wetted Material

302, 314, 316 stainless steel, silicone O-ring, BK-7 glass, rhodium-plated copper or platinum mirror aluminum, rhodium copper, mylar, PTFE

Inlet/Outlet

0.25 in (6.35 mm) OD tubing fittings

Electrical Connector

SUB-D-15

Weight

1.8 kg (4 lb)

Accessories

Platinum mirror

GE Sensing

1211H Two Stage Chilled Mirror Specifications

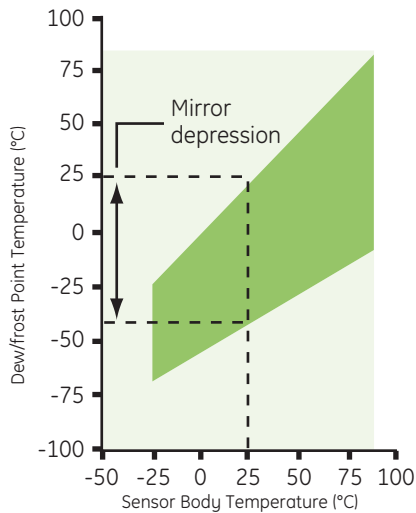
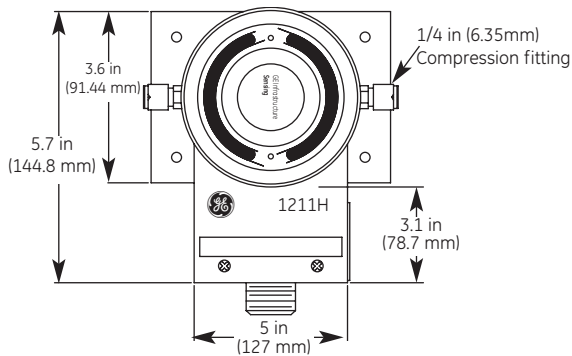

Sensing Element

Four-wire 1/3 Class A DIN 43760 PRT, 100Ω @ 0°C

Dew/Frost Point Accuracy

± 0.2°C

Depression

65°C at 25°C, 1 atmosphere for standard air

Typical Dew Point Measurement Range

-35°C to 25°C Td at 25°C, 1 atmosphere for standard air. (Equivalent to 6 to 100% RH)

Sample Flow Rate

0.25 to 1.25 LPM (0.5 to 2.5 SCFH)

Operating Temperature

-25°C to 100°C

Operating Pressure

1-21 bar (0 to 300 psig)

Power

Derived from analyzer

Sensor Body

Cast aluminum with 314 SS flow cell

Mirror

Rhodium-plated copper (solid platinum optional)

Vapor Barrier

Mylar

Sensor Wetted Material

302, 314, 316 stainless steel, silicone O-ring, rhodium-plated copper or platinum mirror

Inlet/Outlet

0.25 in (6.35 mm) OD tubing fittings

Electrical Connector

MS style multipin keyed connector

Weight

1.8 kg (4 lb)

Accessories

Platinum mirror

Stainless steel vapor barrier

T-100 Four-wire PRTD Temperature Mirror

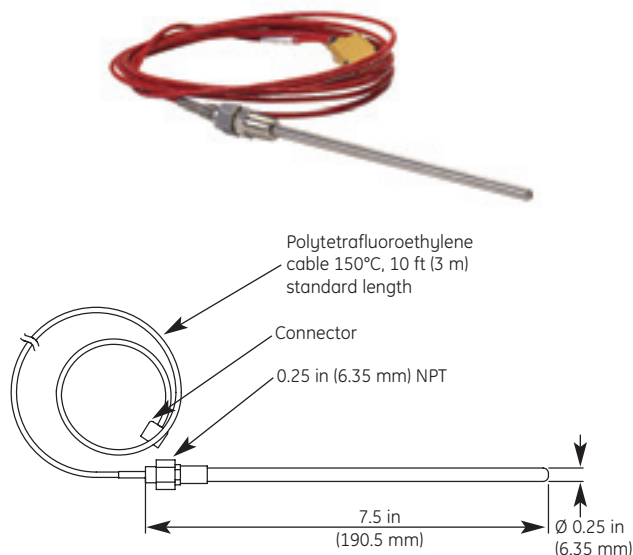

Sensing Element

Four-wire 1/3 Class A DIN 43760 PRT, 100Ω @ 0°C

Accuracy

0.15°C

Range

-100°C to 100°C

Response Time

7 seconds for 25°C to 70°C step change in fluid

Sensor Body Material

Stainless steel

Cable

PTFE insulation rated to 150°C, 3 m (10 ft) length, spring strain relief

Power

Low voltage derived from analyzer

Weight

0.9 kg (2 lb)

Ordering Information

Analyzer	
1	Benchtop
2	Wall Mount
Power	
1	100-240 VAC, 50-60 Hz
2	18-32 VDC
Chilled Mirror Sensor	
0	None
1	1111H Single Stage w/NPT Fitting
2	1111H-GE Single Stage w/Duct Mt Flange
3	D2 Two Stage
4	1211H Two Stage (High Pressure & Temp)
Chilled Mirror Type	
1	Rhodium
2	Platinum
Chilled Mirror Sensor Vapor Barrier	
1	Mylar
2	Stainless Steel
Analyzer to Chilled Mirror Sensor Cable	
0	No Cable 1111H Fixed to Wall Mount
1	10 Ft Standard
2	25 Ft
3	50 Ft
4	100 Ft
5	200 Ft
6	300 Ft
Temperature Sensor	
0	T-100 Affixed to Wall Mount
1	T-100 w/10 Ft Cable (Standard)
2	T-100 w/25 Ft Cable
3	T-100 w/50 Ft Cable
4	T-100 w/100 Ft Cable
5	T-100 w/200 Ft Cable
6	T-100 w/300 Ft Cable

Notes:

- 1 1111H sensors are only available with Mylar vapor barriers
- 2 D2 sensors are only available with stainless steel vapor barriers
- 3 Analyzer to sensor cable will be dependent on which analyzer (bench or wall) and sensor is ordered
- 4 All systems are standard dew point accuracy $\pm 0.2^\circ\text{C}$ Td and temperature $\pm 0.15^\circ\text{C}$ Ta
- 5 For 1111H affixed to wall mount, you must select 1111H and wall unit
- 6 For T-100 affixed to wall mount, you must select the wall analyzer
- 7 18-32 VDC power supply is only available on bench top analyzer

Accessories:

PTFE-GE: FILTER for 1111H Sensor

- Hard shell carrying case for benchtop unit with accessories.
- Calibration-multilayer
- Extended warranty



©2007 GE. All rights reserved.
920-423A_E

All specifications are subject to change for product improvement without notice. Mylar® and Excel® are registered trademarks of DuPont and Microsoft Corporation, respectively. GE® is a registered trademark of General Electric Co. All products denoted with a ® or ™ are registered trademarks or trademarks of GE.