



The Company

Lumeter Limited, established in 1978, now boasts over four decades in the trade and has since become a widely appreciated market leader in the supply and manufacture of grease pumps, grease guns and agricultural fasteners.

In 2015, Lumeter launched the new Springless Patented Cartridge Vacuum Greasing System, including the Multi-gun™ side Lever and Pistol Grip versions.

Despite experiencing a substantial amount of growth since its foundation, the company which is based in Oldbury in the West Midlands, has remained a UK owned family run business dedicated to facilitating the needs of its ever-growing customer base.

Having diversified into the area of specialist equipment for handling fuel, oil, chemicals and 'AdBlue', Lumeter now boasts status as a major supplier occupying the largest range of associated equipment in the UK (a vast product inventory that includes hitch pins, linch pins and 'R' grips, as well as an array of barrel storage tanks and barrel sump pallets).

We offer a telephone technical advice service, parts and back up - serving industry, agriculture, garage, construction markets and manufacturing for OEM's.

We hope you enjoy the efforts we have made to bring to you, our customer, the very best in design and quality.

The Lumeter team welcome new trade enquiries and can supply competitive quotes.

Introduction

Our Aim in Business Is:

To continually improve both our products and our service for the benefit of our customers.

We are committed to:-

- SUPPLYING THE BEST
- IMPROVING OUR SERVICE LEVELS
- IMPROVING OUR ATTENTION TO DETAIL
- GIVING CUSTOMER SUPPORT
- PROVIDING TECHNICAL HELP
- SUPPLYING SPARE PARTS
- FAST DELIVERIES
- COMPETITIVE PRICING



Units Legend

Metres	m (mtr)	Height	H
Millimetres	mm	Minutes	min
Litres	Ltr	Hours	hrs
Centilitre	cc	Volts	v
Kilogram	kg	Amps	A
Length	L	Amps/Hours	A/H
Width	W	Watts	w
Depth	D	Horsepower	hp

Terms and Conditions

Prices are exclusive of Value Added Tax.

Prices available are those ruling at date of despatch - written confirmation upon request.

All prices are ex-works - Carriage is paid on consignments valued £300 (unless stated otherwise in price list or confirmed in writing) and above for England, Wales and the following postcodes for Scotland KA (excluding KA27/KA28) M2/G/EH/DG/KY/PH1-20/FK1-7 and FK9-16.

Other areas and Highlands, Islands, Channel Islands, Northern and Republic of Ireland and all other worldwide destinations. Prices are ex-works unless other arrangements have been confirmed in writing.

Invoices are payable at end of month following invoice date. Title to goods does not transfer to the buyer until payment in full is received.

Non-arrival of goods must be reported within a maximum period of 10 days from despatch, otherwise claims cannot be considered. Invoices are sent separately to facilitate this action.

Claims for shortages or damage must be reported to Lumeter within 24 hours from receipt of goods. Damaged cartons or shortages must be noted on carriers document at time of receipt.

The seller shall not be liable in any way in respect of late delivery howsoever caused, nor shall such failure be deemed to be a breach of contract.

These are abbreviated Terms and Conditions. Full Terms and Conditions are available upon request.

Guarantee

Our products are guaranteed against defective workmanship and materials for a period of 12 months from date of sale to customer against the following conditions.

If the product has not been abused, we will replace, without charge for labour and components, any component found to be faulty after normal use in accordance with our directions within the Warranty period.

Transport costs of the product to us must be paid by the customer. We will charge for the return carriage if the repair is not covered by the warranty.

Any liability incurred by the seller to the buyer is limited to the replacement of the goods, or, at the option of the seller, refund of the price paid by the buyer, and, in particular does not extend to the consequential loss. It is conditional upon the buyer making a written claim to the seller, within 12 months of delivery, setting out the full particulars of such claim, and where possible, returning to us sufficient part of the goods to enable a full examination to be carried out.

Lumeter operate a policy of continuous product improvement such that specifications and drawings/illustrations are for guideline purposes only and products delivered may differ.

Location Map

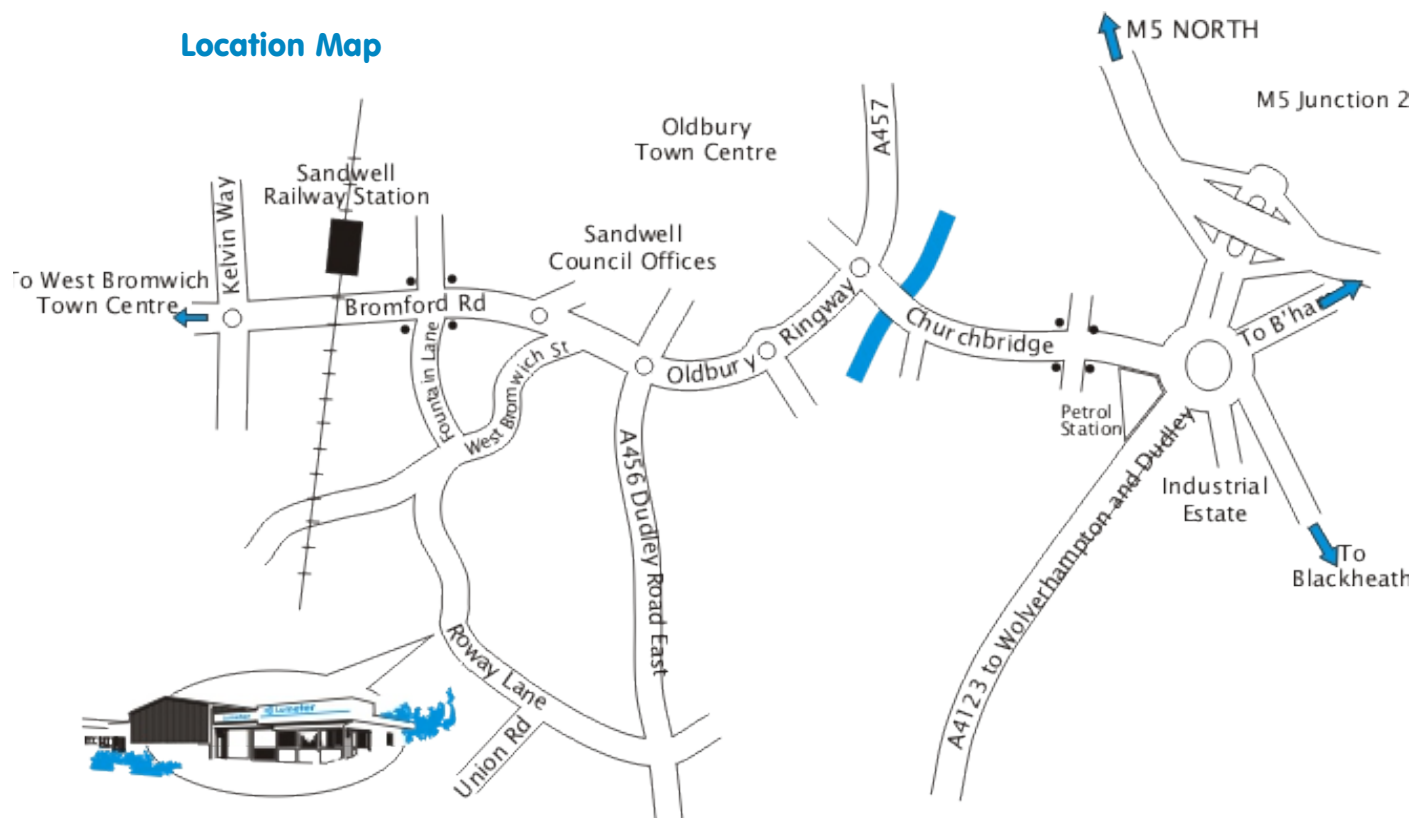

Index

Dispensing Aids	1
Grease Handling	5
Oil Handling	16
AdBlue Dispensing	25
Diesel and Fuel Handling	27
Chemicals and Fluid Handling	35
Hose Reels	39
Storage and Trolleys	41
Waste Handling	45
Fasteners	49
Valves and Fittings	51

Lumeter Ltd
Factory & Showroom
Roway Lane
Oldbury
West Midlands
B69 3EJ
England

 **Lumeter Limited**

| T: +44 (0) 121 544 3090 | F: +44 (0) 121 207 0740 | W: www.lumeter.co.uk | E: enquiries@lumeter.co.uk |



Anti-Spill Funnels

J8055/6 6" (150mm) Heavy duty polyethylene with filter and flexispout. Box Qty 36.

J8055/9 9" (225mm) Heavy duty polyethylene with filter and flexispout. Box Qty 27.



Flexispout Funnels

J8055/SS 160mm with stainless steel flexispout and filter.

J8055/160F 160mm HDPE with plastic flexispout and filter.



Large Garage Funnel

J8055/12GF Black 12" (260 x 170mm) HDPE with universal filter. Box Qty 20.

J8055/OR Orange 12" (260 x 170mm) HDPE with universal filter. Box Qty 20.

J8055/12U Spare water separator filter.



Standard Funnels

J8055/100 100mm HDPE with hanging facility.

J8055/150 150mm HDPE with hanging facility.

J8055/195 195mm HDPE with hanging facility.

J8055/250 250mm HDPE with hanging facility.



3 Piece Large Funnel Set

J8055/20SE 100/150/250mm HDPE. Box Qty 20.



4 Piece Small Funnel Set

J8055/SET4 55/75/100/120mm HDPE. Box Qty 20.



Offset Spout Funnel

J8055/OFF 150mm HDPE with strainer.



Safety Funnel with Lid

J8055/SAF 250mm HDPE with 2" BSP male diecast adaptor.

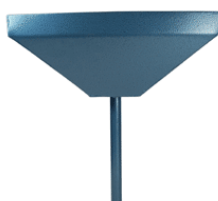

Heavy Gauge Steel Funnel

J8065/25 259 x 216mm with steel mesh filter with 1 1/4" O/D tube.

J8065/205 406 x 259mm with steel mesh filter with 2" O/D tube.



Standard Oil Measures

J8056/1.5 1.5Ltr Heavy duty polyethylene. Box Qty 24.

J8056/5 5Ltr Heavy duty polyethylene. Box Qty 18.



Flexispout Oil Measures

With lid and spout cap.

J8057/1N 1Ltr Heavy duty polyethylene. Box Qty 24.

J8057/2N 2Ltr Heavy duty polyethylene. Box Qty 24.

J8057/3N 3Ltr Heavy duty polyethylene. Box Qty 18.

J8057/5N 5Ltr Heavy duty polyethylene. Box Qty 18.

J8057/SF Small spare flexispout for J8055/4/6 & J8057/1N/2N/3N.

J8057/LF Large flexispout for J8055/9 & J8057/5N.



Measuring Jugs

J8060/J5 5Ltr HDPE.

J8060/J3 3Ltr HDPE.

J8060/J2 2Ltr HDPE.

J8060/J05 0.5Ltr HDPE.

J8060/J025 0.25Ltr HDPE.



Plastic Drain Bowls

J2250 14Ltr Black c/w handles and pourer.



J2253 6Ltr Red c/w pourer and filter rest.



Diecast Zinc Drum Tap

J4175 3/4" BSP Lockable.



Polypropylene Drum Tap

J4174 3/4" BSP White plastic (not lockable).

J4176 3/4" BSP. Lockable.

J4176/B 3/4" BSP. Lockable & Brass.

J4176SE As above but with 2" Trisure male converter. 3/4" Poly Tap.



Solid Brass Drum Tap

J4176/B 3/4" BSP. Lockable.

J4176/B1 3/4" BSP. Brass back nut.

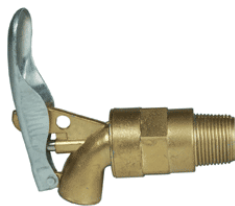

Self Closing Drum Tap

J4177 All metal - 3/4" BSP. Lockable.



Polyethylene Drum Tap

J4176/G 2" BSP.

J2654/TS Converter - Trisure to 2" BSP (F). For using J4176/G with plastic 205Ltr barrels.



Aeroflo Tap

J2650/R 61mm. Fits male threaded 25Ltr drums. Self venting for smooth splash free flow.



Jumbo Portable Transfer Pump

Suitable for diesel, gas oil, light oils, hydraulic/brake fluid and anti-freeze.

A1004 Supplied with 2 x 1m of hose for inlet and outlet.

Suction Gun

J0150 500cc capacity. Supplied with 270mm flexitube.

J0100 1000cc capacity. Supplied with 270mm flexitube.

J0100/5 228mm 1/4" BSP BZP tube

Dispensing Aids

Oil Cans, Sprayers, Jerry Cans and Sealant Gun



Steel Oil Cans

Manufactured from "Rust proofed" coated steel.

J5000/2 200cc with rigid and flexi spout. Steel pump.

J5000/3 300cc with rigid and flexi spout. Steel pump.

J5000 500cc with rigid and flexi spout. Steel pump.

J5000/5 500cc with rigid and flexi spout. Brass pump.

J5000/10 1000cc with rigid and flexi spout. Brass pump.



Polyethylene Oil Can

J5001 500cc polyethylene body with rigid and flexi spout.



Plastic Sprayer Bottles

J0001 750cc with chemical resistant head.



Brake Cleaner & Chemical Pressure Sprayers

J0002 1.5Ltr. Box Qty 12.

J0002/WB 1Ltr with brass nozzle. Box Qty 12. (Illustrated).



Sealant Gun

J0003 Metal construction. Suitable for 310 and 400ml cartridges.



Steel Jerry Cans

J0007 10Ltr Heavy Duty. Box Qty 6.

J0004 20Ltr Heavy Duty. Box Qty 4.

J0008 Flexi spout for above - Metal.

J0008R Non-glug rigid spout for above - Metal.

J0014 Jerry Can Spout with plastic flex.

Grease Types

Our Grease Guns and Pumps are designed to handle most of the popular multipurpose greases to NLGI - No.2 specification made with light to medium base oil viscosities. However, with greases for special applications, which may have high viscosity base oils and/or special additives, problems may be encountered. If so, the question of pumpability should be referred



Multi Gun Range®™

Patented Grease Gun Barrel Assembly: Patent GB 2525503

Our new comprehensive range of Grease Guns are fitted with our Patented Vacuum Barrel System. By using the vacuum principle the grease is evacuated from the cartridge to the Grease Gun Head. The inherent problems of loading grease cartridges into conventional spring operated grease gun are a thing of the past. The quick, simple and clean method can be used with any standard 400g cartridges to DIN1284 standards, and for threaded cartridges 500g small dia threaded cartridge and the 400g threaded cartridge.

Springless Patented Barrel System

Benefits:

- Clean easy loading
- Simple to use
- Enables the user to buy cartridges from any source for evacuation of the grease
- Safety - no possibility of trapping fingers when spring pressure released
- Gun can be store loaded thereby avoiding oil leakage with spring pressure grease guns

A1036MG Twin Handled Multi Gun®

(Dispenses Standard DIN1284/ 500g/400g Threaded Cartridges)

Supplied with

- ♦ Large adapter for the Patented Barrel Assembly for Standard DIN1284 Cartridges
 - ♦ 5 x Follower Seals to enable a supply of loaded cartridges to be available (replacement seals are available at a nominal cost)
 - ♦ 18" Spring Guard Hose & 4 Jaw coupler
 - ♦ Hose Parking to prevent contamination
 - ♦ Threaded head for 500g cartridge
 - ♦ Adapter for use with the large dia threaded 400g cartridge
 - ♦ Security ring (for use with screw thread cartridges)
 - ♦ Zinc plated barrel and handles with plastic non-slip grips
- Supplied in a printed retail box with full operating instructions

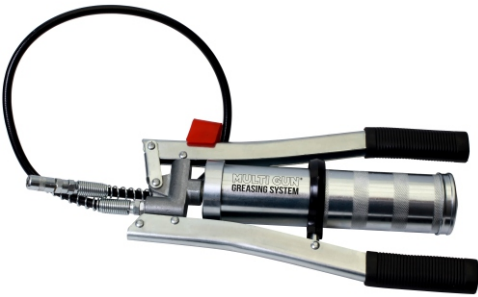

A1038 Side Lever Grease Gun

(for Standard Cartridges)

This gun can use Standard Cartridges DIN1284 with the Patented Barrel Assembly

Supplied with:

- ♦ 5x Follower Seals
 - ♦ Zinc plated barrel and grey head/handle assembly with a plastic grip
 - ♦ 8" Hose and 4 Jaw Coupler
- ♦ Supplied in a printed retail box with full operating instructions



A1037 Pistol Grip Grease Gun

(for Standard Cartridges)

This gun can use Standard Cartridges DIN1284 with the Patented Barrel Assembly

♦ Supplied with:

- ♦ 5 x Follower Seals
 - ♦ Large dia. threaded 400g Cartridge
 - ♦ Zinc Plated Barrel with grey head
 - ♦ Zinc tube with 4 Jaw coupler
- ♦ Supplied in a printed retail box with full operating instructions



A1036F Follower Seals

Pack of 5 Replacement Follower Seals

Grease Types

Our Grease Guns and Pumps are designed to handle most of the popular multipurpose greases to NLGI - No.2 specification made with light to medium base oil viscosities. However, with greases for special applications, which may have high viscosity base oils and/or special additives, problems may be encountered. If so, the question of pumpability should be referred to the appropriate grease manufacturer.

Heavy Duty Side Lever Grease Gun

Develops up to 10,000 psi - to DIN 1283. Screwed end cap for easy cleaning, quick discharge of empty cartridge. Grease capacity 500cc bulk fill or 400g grease cartridge. Bulk filler nipple/air release. Precision machined 10mm piston for higher output/stroke. Extra strong spring. Long handle and barrel for extra leverage. Plastic handle grip and knurled barrel for a firm hold. Individually retail boxed with instructions.



A1019B Professional Gun with "Ram Rod" system. Steel Head.

A1023 Professional side-lever grease gun. Steel Head.

A1010/KC Professional Gun with cast head (side-lever).

A1039 Twin Piston grease gun. High pressure and Output.



Varimatic Hand Compressor Grease Gun

This grease gun has a valve in the head to allow grease to enter the chamber even with very short handle movements. "For limited space situations and extra pressure." Fitted with filler nipple/air release. Cast iron head.

A1033SE Side-lever grease gun c/w J0515HD 4 JAW

Twin Handled Grease Gun

A1034M For 500g Fuchs cartridges, c/w 12" Nylon Hose and 4 JAW and Hose Park to avoid contamination.

A1034MSE As above but with Adapter for Lube Shuttle.



Major Pistol-Grip Grease Gun

Dual purpose greaser. Fitted with filler nipple/air release.

A1024S 500cc bulk fill or 400g cartridge. With straight extension tube and 4 jaw coupler.



Certalube Grease Gun

Cast head, variable stroke pistol grip with extendable arm for use as side-lever slip resistant grip. Filler nipple and air bleed valve.

A1026/HDH Supplied with cranked tube, 12" rubber hose and HD couplers.



Air Operated Grease Gun

Operates from air supply of max. 8 bar. Can be coupled up to a vehicle compressor of 3cfm min. air volume.

J0181 Automatic. Runs continuously when trigger is held open. (Other details as J0180)



12v Rechargeable Grease Gun Kits

Supplied in a carrying case, with charger, two batteries, shoulder strap, 400mm grease hose with 4 jaw coupler. Air release valve.

A2000 12V Cordless Grease Gun, 500cc bulk fill or 400g cartridge. Max pressure 6000 psi.

A2000HD Heavy Duty 12V Grease Gun, 500cc bulk fill or 400g cartridge. Max pressure 8000 psi.

A2000/LITH 14.4V Cordless Grease Gun with Lithium Battery, 500cc bulk fill or 400g cartridge.



Grease Handling

Heavy Duty Greasers for the Professionals

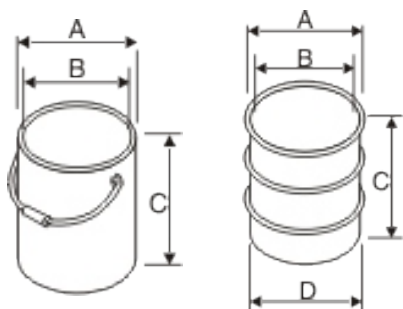

Greasing System - Keg Sizes for Hand and Airomatic Greasing

Our Greasers are designed to suit grease containers and kegs for most countries. In cases of doubt, please specify dimensions **A, B & C** of grease containers when purchasing. The net contents of the container should also be advised.

A=Outside diameter of keg rim, **B**=Inside diameter of keg, **C**=Inside depth of container, **D**=Outside diameter, **T**=If tapering keg - internal diameter at top and bottom.

Heavy Duty 'High Pressure' Direct-on-Nipple Greasers

All greasers are supplied with rubber-edged follower plates as standard to reduce grease vortexing and cavitation in the containers. 1.5 metres of high pressure rubber flexihose (min bend radius 35mm) and 4 jaw coupler with cranked extension tube. Pressure exceeds 6000psi.



J4512SE For 12.5kg grease kegs. With extra strong lid. Heavy Duty H.P. Greaser.

J4515SE For 12.5kg grease kegs. Economy model*.

J4503SE For 3kg grease kegs. H.P. Mini Greaser.

J4503/9SE For 4.5/5kg grease kegs. H.P. Mini Greaser.

A1058SE For 18/20kg grease kegs. Midi Greaser.

A1058PSE For 18kg plastic grease kegs.

A1021SE For 20kg taper Drum H.P. Greaser.

A1098SE For 25kg grease kegs.

J4550SE For 50kg grease kegs. Major Greaser.

A1096SE HP Greaser Spares Kit - Internal seals, 'O' rings, coupler and HP valve.

J4152/SEALS Seals and 'O' ring kit.

*Note: Economy version with pressed round lid. (2800psi max). Light duty use, the handle will lock when void is full.

Plastic 18kg Drums

A1063SE/Whit 18kg High Pressure Greaser for Whit Keg

A1062SE/QHI QHI Plastic Keg

A1062SE/POR 18kg High Pressure greaser for Petro Can

New Plastic Grease Kegs

Please contact us for a quotation for your required specification



H.P. Multi-Shot Pressurised Greaser

Gun dispenses on average 60-70 shots per pump stroke, 3m grease hose.

J4514 For 12.5kg grease kegs.

NB: We can supply systems for any keg size.

Grease Handling Grease Chassis Filler/Transfer Pumps

High Volume - 'Low Pressure'

All greasers are supplied with lid and rubber-edged follower plates as standard, to reduce the grease vortexing and causing cavitation in the containers.

Auto Chassis Lube Filler Pump

High volume output for filling auto chassis lubrication system reservoirs. Supplied with 1.5m of 3/8" (9mm) hose and 1/4" BSP male end fitting for your quick release connector and lid. Follower plate supplied as an optional extra if required.



J9512SE/CF For 12.5kg grease kegs.

J9512SE/CFF For 12.5kg grease kegs. With female fitting J2252/CFF.

J9515SE/CF For 12.5kg grease kegs. Economy version with pressed round lid.

J9515SE/CFF For 12.5kg grease kegs. With female fitting J2252/CFF.

A1067SE/CF For 18/20kg grease kegs.

A1068SE/CF For 25kg grease kegs.

A1031SE/CF For 50kg grease kegs.

New Plastic Grease Kegs - Please contact us for a quotation for your required specification

Optional Extra's

J2252/CFM Male coupler 1/4" BSP female threads.*

J2252/CFF Female coupler 1/4" BSP female threads.*

A1090SE Male coupling with filler tube (for use with CFF pump). 8" Tube

*Note: The female coupler fits most male fittings on chassis systems. (ISO 'B' Type).

Low Pressure Grease Filling Unit

For filling modified Grease Guns A1024MSE and A1019MSE.



J9512SE For 12.5kg grease kegs.

A1031SE For 50kg grease kegs.

500cc Pistol Grip Grease Gun

Modified to be filled by J9512SE or A1031SE via Quick release fitting.



A1024MSE Spec. Same as A1024. (See Grease Gun Section).

500cc Side Lever Grease Gun

Modified to be filled by J9512SE or A1031SE via Quick release fitting.



A1019MSE Spec. Same as A1019. (See Grease Gun Section).

Low Pressure Grease Filler Pumps

J9528SE For 12.5kg grease kegs. (Gun not included). Midi Greaser.

J9551SE For 50kg grease kegs. We can supply systems for any keg size.

Bulk Filler Transfer Pumps

High output. Supplied with 1.5m of 3/4" (19mm) hose. For transfer of grease or bulk filling grease guns.

A1061SE For 12.5kg grease kegs.

J9518SE For 18kg grease kegs.

A1082SE For 50kg grease kegs.

J9512/BR180 Pump only for 180kg grease drum with 3/4" O/D pipe for hose.

Note: Accessories for 180kg Pump: Lid, Follower Plate, Hose (Specify length).

NB: We can supply systems for any keg size.



Grease Handling

Grease Hose for Manual Equipment

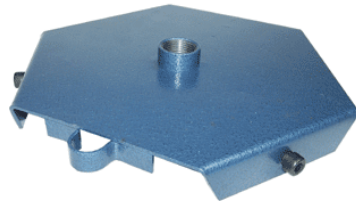

Rubber Edged Follower Plate (Also for use with Air Operated)

JL4220R For use with 12.5kg Midi Greasers

J9545/6SE For use with 18kg Greasers.

J9545/6TSE For use with 18kg Taper kegs.

J9545/9SE For use with 25kg Greasers.

J9545/9TSE For use with 25kg Taper kegs.

JL4222R For use with 50kg Major Greasers.

M8065 For use with 60kg Greasers.

M8066 For use with 180kg Greasers.

Robust Steel Lid

J4503/7SE For use with 3 & 5kg Mini Greasers. (Hex)

J9546/2SE For use with 12.5kg Midi Greasers. (Round)

J9546/3SE For use with 18/20kg Greasers. (Hex)

J9546/4SE For use with 25kg Greasers. (Hex)

J9546/1SE For use with 50kg Major Greasers. (Round)

J9546/180SE For use with 180kg Greasers. (Round)

Flexihose (Minimum bend radius for HP hose 35mm)

Not to be used for Air Operated

J0108 8" (200mm). Nylon Burst Pressure 1000 Bar 1/8" BSP male end fittings.

J0108R 8" (200mm). Rubber Burst Pressure 1000 Bar 1/8" BSP male end fittings.

J0112 12" (300mm). Nylon Burst Pressure 1000 Bar 1/8" BSP male end fittings.

J0112R 12" (300mm). Rubber Burst Pressure 1000 Bar 1/8" BSP male end fittings.

J0118 18" (450mm). Nylon Burst Pressure 1000 Bar 1/8" BSP male end fittings.

J0118R 18" (450mm). Rubber Burst Pressure 1000 Bar 1/8" BSP male end fittings.

A1036H 18" Hose with Spring Guard & 4 Jaw Coupler.

Time Savers Snap-On Flexihose

Not to be used for Air Operated

A1006SE 8" (200mm) Nylon. 1/8" BSP c/w 4 jaw coupler.

A1027SE 8" (200mm) Rubber. 1/8" BSP c/w 4 jaw coupler.

A1008SE 12" (300mm) Nylon. 1/8" BSP c/w 4 jaw coupler.

A1028SE 12" (300mm) Rubber. 1/8" BSP c/w 4 jaw coupler.

A1013SE 18" (450mm) Nylon. 1/8" BSP c/w 4 jaw coupler.

A1029SE 18" (450mm) Rubber. 1/8" BSP c/w 4 jaw coupler.

High Pressure Flexihose

Not to be used for Air Operated

J4500/1 1.5m with 1/8" BSP male end fittings. Burst pressure 1000 Bar.

A1015SE 3m with 1/8" BSP male end fittings. Burst pressure 1000 Bar

High Pressure Flexihose Kit

Not to be used for Air Operated

A1014SE 1.5m, 1/8" BSP with cranked extension tube and 4 jaw coupler. (Illustrated).

A1016SE 3m, 1/8" BSP with cranked extension tube and 4 jaw coupler.

Grease Handling

Air Operated Greasers for the professional



Airomatic Greasing Systems - Technical Data

Airomatic greasers are suitable for use with multipurpose greases to NLGI - No.2 specification made with light to medium base oil viscosities. However, with greases for special applications, which may have high viscosity base oils and/or special additives, problems may be encountered. If so, the question of pumpability should be referred to the appropriate grease manufacturer.

Power source is by highly efficient trouble free airo-motors of proven design.

Operating pressure 3.5 bar minimum to 8 bar maximum.

For extended operating life we recommend pressures of 6 bar in conjunction with filtered and lubricated air lines. See Lumeter Air Management System code: M5511.

Safety Warning: 100:1 ratio not to be used with hand held equipment.

Note: Ensure only air operated grease flexihoses are used with this equipment.

Product Code	M4018	M4020	M4060	M4080	M4045	M4035	M4019	M4021	M4061	M4081
Ratio	50:1	50:1	50:1	50:1	5:1	5:1	100:1	100:1	100:1	100:1
Maximum Line Pressure - bar	400	400	400	400	40	40	800	800	800	800
Delivery Capacity - kg/min	1.4	1.4	1.4	1.4	5	5	0.7	0.7	0.7	0.7
Shank Length - cm	38	45	75	95	95	50	38	45	75	95
External Shank Dia. - mm	28	28	28	28	40	40	28	28	28	28
Suitable for kegs - kg	12.5	18-30	50-60	180	180	STUB	12.5	25	50	180
Air Inlet/Grease Outlet	1/4	1/4	1/4	1/4	1/4 1/2	1/4 1/2	1/4	1/4	1/4	1/4
Application	Hand Held			Transfer			Special Applications			

Air Operated Greaser Kit

Pump complete with lid, follower plate, 4m hose and accessories ready for fitting to your grease keg. (Also available (suffix L2) our own brand).

M4018KIT For 12.5kg grease kegs. 50:1.

M4020/18SE For 18kg grease kegs. 50:1.

M4020/18PSE For 18kg plastic kegs. 50:1.

M4020/20SE For 20kg grease kegs. 50:1.

M4020/25SE For 25kg grease kegs. 50:1.

M4060KIT For 50kg grease kegs. 50:1.

M4080KIT For 180kg grease drums. 50:1.

New Plastic Grease Kegs - Contact us for a quotation

Air Operated Greaser Kit with Air Management System

Pump complete with lid, follower plate, 4m hose and accessories ready for fitting to your grease keg, complete with Air Management System.

M4018KIT/AIR For 12.5kg grease kegs. 50:1.

M4060KIT/AIR For 50kg grease kegs. 50:1.

M4080KIT/AIR For 180kg grease drums. 50:1.

Air Operated Greaser Kit Complete with Trolley

Pump complete with lid, follower plate, 4m hose and accessories ready for fitting to your grease keg, complete with Air Management System and Trolley. (As illustrated).

M4018KIT/COMP For 12.5kg grease kegs. 50:1.

M4060KIT/COMP For 50kg grease kegs. 50:1.

M4080KIT/COMP For 180kg grease drums. 50:1. With 4 Wheel Trolley (M4388).



NB: We can supply systems for any keg size.

Grease Handling

Air Pump Accessories



Air Management System

This compact system combines pressure regulator with filter, lubricator and gauge. It optimises the efficiency and the life of the pumps when in regular use, also preventing the seizure of moving parts. (Ideally should be installed next to pump).

M5511 Air Management System

M5511/1 Gauge - Air Management System.



Grease Control Gun

1/4" BSP (Male) Inlet.

M8092SE Complete with 'Z' swivel, cranked tube & hydraulic coupler. (Illustrated).

M8092/KIT Complete with 'Z' swivel, cranked tube, hydraulic coupler & 18" hose.

M8082SE Gun only with cranked tube & hydraulic coupler.



'Z' Swivel Connection

M8090 1/4" BSP Male & Female ends. (also illustrated with gun).

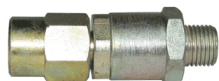

Straight Swivel

M8091 1/4" BSP Male & Female ends. Useful accessory for pump body outlet.



Aromatic Grease Delivery Hose

Working pressure 415 bar/burst pressure 1660 bar.

J0182/4 4m with 1/4" BSP Male/Female end fittings.

J0182/5 5m with 1/4" BSP Male/Female end fittings.

J0182/10 10m with 1/4" BSP Male/Female end fittings.

J0182/15 15m with 1/4" BSP Male/Female end fittings.

J0182/20 20m with 1/4" BSP Male/Female end fittings.



High Pressure Rubber Grease Flexihoses

Use with air operated grease control gun. Working pressure 415 bar/burst pressure 1660 bar.

J0183/R 9" (200mm).

J0184/R 12" (300mm).

J0185/R 18" (450mm).

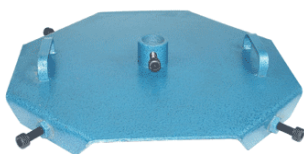

Steel Lids for Aromatic Greasers

M8050SE For use with 12.5kg grease kegs. (Round)

J2280/18SE For use with 18/20kg grease kegs. (Six sided as illustrated).

J2280/25SE For use with 25kg grease kegs. (Six sided as illustrated).

M8053SE For use with 50kg grease kegs. (Round).

M8054 For use with 60kg grease kegs. (Round).

M8056 For use with 180kg grease kegs. (Round).

*Note: When ordering lid only, specify diameter of shaft.



Pre-Set Metered Grease Control Gun

1/4" BSP (Male) Inlet. Min. flowrate 0.10kg/min, Max. flowrate 2kg/min. Min. temp. +2°C. Max. temp. +50°C. Max. pressure 4300 psi. Accuracy + or - 0.5%. Max. cumulative total = 9999kg. Min. pre-set value. 0.010kg. Max. batch pre-set 999.9kg.

M4236 Complete with rigid nozzle and straight swivel.



4 Jaw Coupler

J0515 1/8" BSP.

J0515HD Heavy duty 1/8" BSP.

J0515/M10 M10 for 12v Grease Guns.



Push On Connector

J0523 1/8" BSP.

J0501 8mm.



Pointed Connector

J0522 1/8" BSP.

J0522/L 1/8" BSP. Long Pointed



Cranked Steel Rigid Feed Tube

J0520 Tapered 1/8" BSP.



J0518SE Tapered 1/8" BSP c/w hydraulic coupler.



Straight Steel Rigid Feed Tube

A1059/12 12" (300mm).

A1059/18 18" (450mm).



Swivel Connection for Flexihose

J0512 1/8" BSP



Standard Filler Nipple

J0521 1/8" BSP Bright zinc plate finish.



Universal Swivel Button Head Coupler

J0514 1/8" BSP for standard BH nipple.



Button Head 'Slide-On' Coupler

J0509 1/8" BSP for standard BH nipple.



Button Head 'Hook-On' Coupler

J0510 1/8" BSP for standard BH nipple.



Giant Button Head 'Hook-On' Coupler

J0508 1/8" BSP for 22mm BH nipple.

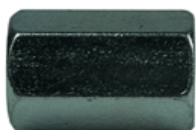

Steel Hexagon Joint

J0517 1/8" BSP Internal thread.

Grease Handling

Couplers and Connectors



Snap-On Handy Greasing Extension

A1020SE 1/8" BSP.



Snap-On Right Angled Coupler

A1050SE 1/8" BSP.

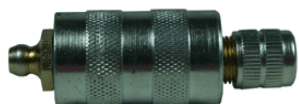

Snap-On Concave Coupler

A1051SE 1/8" BSP.



Snap-On Pointed Nozzle Coupler

A1052SE 1/8" BSP.



Snap-On/Hook-On Coupler

A1053SE 1/8" BSP.



Snap-On/Slide-On Coupler

A1054SE 1/8" BSP.



Standard Swivel Snap-On Button Head Coupler

A1055SE 1/8" BSP.



Snap-On Giant Button Head Coupler

A1056SE 1/8" BSP.



Snap-On Rigid Extension with Coupler

A1057SE 1/8" BSP.



Snap-On Needle Coupler

A1060 1/8" BSP.

Grease Handling

Grease Nipples - Popular Range

Grease Nipples

Supplied in units of 100 (minimum quantity 100 pieces per size).

- Steel case hardened to prevent wear.
- Batch tested to 8000psi.
- Zinc plated and fully chromated.
- To BSI 1418/DIN71412/SAE J534/J15B1574

Y = Availability

Tread Type	Straight	45° Angle	90° Angle	Button Head	Straight Long
METRIC					
6 x 1	Y	Y	Y	Y	-
8 x 1	Y	Y	Y	-	-
8 x 1.25	Y	Y	Y	Y	-
10 x 1	Y	Y	Y	-	-
10 x 1.5	Y	Y	Y	Y	-
12 x 1.5	Y	Y	-	-	-
BSP					
1/8"	Y	Y	Y	Y + Brass	-
1/4"	Y	Y	Y	Y + Brass	-
3/8"	Y	-	-	Y	-
BSF					
1/4"	Y	Y	Y	-	15/16"
5/16"	Y	Y	Y	Y	-
3/8"	Y	-	-	-	-
UNF					
3/16"	Y	-	-	-	-
1/4"	Y	Y	Y	-	15/16"
5/16"	Y	Y	Y	-	-
3/8"	Y	Y	Y	-	-
WHITWORTH					
1/4"	Y	Y	Y	-	-
AMERICAN PIPE					
1/8"	Y	Y	Y	-	-
DRIVE FIT					
3/16"	Y	-	-	-	-
1/4"	Y	Y	Y	-	-
5/16"	Y	-	-	-	-
6mm	Y	(Also Concave)	-	-	-
8mm	Y	-	-	-	-

Stainless Steel Grease Nipples

SEE PRICE LIST FOR AVAILABILITY.

Grease Handling

Grease Nipple Boxes and Extension



Mini Pistol Grip Grease Gun

A1012 125cc approx. With straight tube and 4 JAW coupler



Push Grease Gun

J0330 60cc with push on connector. Can be used with oil above SAE30.

J0334 150cc with push on connector. Can be used with oil above SAE30.

J0336 300cc with push on connector. Can be used with oil above SAE30.



Grease Nipple Extension

GNHEX1/8BSP 1/8" BSP male/female 23mm length.

Grease Nipple Boxes



J9130 150 Assorted Imperial Straight and Angled (BSP/BSF/UNF).

J9131 150 Assorted Metric Straight and Angled (M6/M8/M10).

J9132 80 Assorted Metric Straight and Angled (M6/M8/M10).

J9133 80 Assorted Imperial Straight and Angled (BSP/BSF/UNF).

Grease Nipple Caps with Strap



J9134R Red. Packs of 100.

J9134Y Yellow. Packs of 100.

Not to be used with Chemicals, Petrol, other Corrosive or Volatile Liquids unless specified. Do not test pumps with water. Keep pumps well oiled when not in use.



Lever Drum Pump

High output lever action. Oil and Anti-freeze pump. 400cc per stroke (approx.). Extra strong. Telescopic tube. Anti drip filter cap.

- J3016D2** For 205Ltr drum.
- J3016/48** For 4' tank.
- J3016/25** For 20/25Ltr drum.
- J3016/25SE** As above for 20/25Ltr drums c/w J2650/S convertor for male threaded drums.
- J3016/25KIT** J3016/25SE c/w 1.5m outlet hose with shut off valve and nozzle.
- Optional extra:** Above pump supplied with 'S' (J2650/S) adaptor that clamps on to most male treads.
- A1025SE** 1.5m outlet hose with shut off valve and nozzle.



Gear Oil 'Stirrup' Pump

With 1.7m outlet hose, anti-drip 13mm o/d 90° spout, drain down and nozzle storage facility. Designed to fit those awkward to access filler points with a minimum i/d of 14mm. 2" BSP male thread. Pumps on down stroke. Designed for use with trolley A1083/SLB.

- J9022** For 20/25Ltr containers. Suitable for gear and all lubricating oils.
- J9022/S** J9022 pump supplied with 'S' (J2650/S) adaptor (fits most male threads).
- J9022/TS** J9022 pump for trisure threaded drums.
- J9022/61** J9022 pump supplied with a DIN61 Adaptor (female to female adaptor)



Piston Pump

Suitable for lubricants, cellulose thinners, industrial solvents, chemicals cleaners and detergents. Nylon suction tube, steel nylon coated rod, viton seals. Check suitability for product before using.

- J3010/25** For 20/25Ltr containers. 500mm suction tube.
- J3010/205** For 205Ltr containers. 1000mm suction tube with 2" BSP adaptor.

Note: 20/25Ltr supplied with either A or B adaptor. (Please specify or choose from the adaptors on page 18 supplied at extra cost).



Robust Heavy Duty Oil Pump

With 1.5m flexihose, valve and nozzle. Suitable for SAE 90 and heavier oils. Ideally suited for pumping heavy gear oil in cold climatic conditions.

- A1064SE** For 20/25Ltr containers. Supplied with 2" BSPM Bush (P1734/G).*
- A1066SE** For 60 to 205Ltr barrels. Supplied with standard 2" BSP adaptor.

* Other adaptors available at extra cost. (See page 18).



Hand Operated Jumbo Semi-Rotary Pump

Cast iron, double acting with bronze vanes. For use with water, diesel and lubrication oils.

- K0** 1/2" BSP Inlet/Outlet. Flow rate 12Ltr/min.
- K1** 3/4" BSP Inlet/Outlet. Flow rate 22Ltr/min.
- K2** 1" BSP Inlet/Outlet. Flow rate 28Ltr/min.
- K3** 1 1/4" BSP Inlet/Outlet. Flow rate 40Ltr/min.
- K5** 1 1/2" BSP Inlet/Outlet. Flow rate 50Ltr/min.

Accessories: Inlet tubes, hose tails, hose and adaptors.

Not to be used with Chemicals, Petrol, other Corrosive or Volatile Liquids unless specified. Do not test pumps with water. Keep pumps well oiled when not in use.



1" Rotary Pump

250cc per revolution (approx.). With 3 piece steel inlet tube with non-return valve, 2" BSP adaptor and chrome plated outlet pipe.

P0201 For 205Ltr barrels.

P0201/48SE As above but for 4' tanks. 1 piece tube.

Optional extra:

P0204SE Steel suction tube for 4' tanks, fitted with non-return valve.

P0205 Locking bracket.

A1030SE 1.5m outlet hose with nozzle.

P0201/1 Extension tube and fitting.



Metered Rotary Pump Kit

Mechanical meter, 3m hose, nozzle and 1" rotary pump. Suitable for Oil and Diesel.

P0201SE For 205Ltr barrels. (Illustrated).

P0201TSE As above but for 4' tanks.



Heavy Duty 3:1 Quick Flow Barrel Pump

For lubricating oils upto SAE 30. Max. delivery 70 Ltr/min.

J3045/G Supplied with 1.8m dispensing hose and nozzle.



Side Lever Oil Gun

A1018 500cc. For oil over SAE 30.

20/25Ltr Mobile Gear Oil Unit

Fully adjustable to fit all known 20/25Ltr containers (round, square and rectangular). Pump is held firmly by the trolley unit. For gear oil, automatic transmission fluids and all other lubricating oils. Easy changeover of containers. Pump bracket secures drum.



A1083/J9022 Mobile Gear Oil Unit

A1083/J3016SE With J3016SE lever pump, 1.5m hose and anti-drip nozzle.

A1083/P0202SE With P0202 rotary pump, 1.5m hose and anti-drip nozzle.

A1083/A1064SE With A1064SE heavy duty oil pump, 1.5m hose and anti-drip nozzle.

A1083/J9022TS For trisure threaded drums.



Steel Gear Oil Bucket

With fully reversible hand rotary pump, clear PVC hose and nozzle. Hard powder coat finish as standard.

A6000SE 10.5Ltr (approx.) Robust steel base. Delivers and retrieves.

Optional extra:

A6003SE Outlet shut off valve kit.



Steel Gear Oil Bucket with Lever Pump

Heavy duty pump. With hose, shut off valve and nozzle. Hard powder coat finish as standard.

A6002SE 10.5Ltr (approx.) Robust steel base. Delivers only.



High Pressure Volume Bucket

For dispensing oil and grease via giant button head grease fitting. Steel gear oil bucket.

A6004SE With high pressure pump, hose and giant button head connector.

Accessories: Other connectors available see greasing section.



50Ltr Mobile Oil Dispenser

Heavy duty with handles/skids for easy handling into vans. Completely oil tight.

A6001SE All steel construction. 2 x 2" BSP fittings and bungs.

Optional extra:

P0202 Reversible rotary pump.

A1025SE 1.5m outlet hose with valve and nozzle.

Note: Other types of pumps including air operated can be fitted.



24Ltr Air Discharge Oil Dispenser

24Ltr tank, level indicator and oil dispensing gun.

M3327 Maximum pressure 7 bar.

Oil Handling

Pump Adaptors and Converters



60mm Tournex & 34mm Snap-Top Adaptor

J2650/A For snap-top steel and some plastic 20/25Ltr containers. (Threaded for Plysu).



2" BSP Adaptor

J2650/B For Plastic 205Ltr barrels and 60Ltr drums.

J2650/2 For Steel 205Ltr barrels and 60Ltr drums.



Strong 2" BSP Polyfibre Adaptor

J2650/P For 25mm to 34mm tube dia. □

J2650/N For 19mm 28mm tube dia.

J2650/M For 32mm 42mm tube dia.



2" BSP Converter

J2650/S 2" BSP female - locks onto any male thread with a thumbscrew.



Plastic Trisure Adaptor

J2650/TW 2" BSP male to 3/4" BSP female.



Universal Plastic Adaptor

J2650/U Plastic.



Plastic Ring Converter

J2654/ADM

Threads: 70 x 6mm male to 2" BSP female. **Colour:** Blue. **Application:** Plastic drums with MAUSER Buttress plugs 70 x 6mm. **Common Drum Types:** Mauser, Rexam Harcostar, Wiva, Gally, Dynoplast, Roug, Ostensjo.

J2654/TS

Threads: 56 x 4mm male to 2" BSP female. **Colour:** Orange. **Application:** Plastic drums with TRISURE-EURO Buttress plugs 56 x 4mm. Most plastic drums 20, 25, 50 & 60Ltr. **Common Drum Types:** Van Leer, Economic Drums, Gem Plastics, Rexam Harcostar, Dynoplast, Roug, Hannells, Soltralentz, Schutz.

J2654/DIN61

Threads: DIN 61 female to 2" BSP female. **Colour:** Yellow. **Application:** DIN 61 external screw necks on 'L' ring drums or IBC's, Plysu 20-25Ltr drums with 59mm necks, Valerex 60mm necks, Dynoplast 25Ltr drums with DIN 61 neck. **Common Drum Types:** Van Leer (Valerex), Economic Drums, Galley, Mauser, Soltralentz IBCs, Schutz Drums and IBCs, Van Leer Unicubes.

J2654/DIN71

Threads: DIN 71 female to 2" BSP female. **Colour:** Brown. **Application:** 'L' ring drums from Germany with large aperture necks. **Common Drum Types:** Mauser, new Castrol & "Monty".



50mm to 2" BSP f/f Adaptor

J2654/50 Fits Fuch's 20 Ltr brief case drum - Use with Oil Pump J9022



Aluminium Ring Converter

J9024/13 59mm female to 2" BSP female tread.

J9024/15 2" BSP female to 2" Buttress female thread.



IBC Cap/Adaptor

J3040/CAP 2" BSP bung.



Aromatic Pumps

We recommend that all air operated pumps are used with an Air Management System (M5511 or similar) for extended operating life. It is strongly recommended that a pressure relief valve is fitted to fixed lube lines. They are designed to overcome the pressure build up due to heat expansion. Air operated pumps should not be left connected to an air supply and left unattended for long periods. Considerable damage or loss could occur if system failure occurs down stream of pump. Always provide adequate safety systems or disconnect from air supply.

All flow rate values are free flow estimates, flow rate can change depending on viscosity, temperature of the liquid and outlet system. These well proven, state of the art pumps are designed for long trouble free life. Operating pressures 3-8 bar min/max. Maximum air consumption 125Ltr/min @ 8 bar.

Double Acting Oil Pumps - Technical Data

Product Code	Ratio	Air Inlet (BSP)	Oil Outlet (BSP)	Hose Dia. Ltr/min	Free flow Rate Ltr/min	Flow @ 10m Ltr/min	Flow @ 20m Ltr/min	Flow @ 40m Ltr/min
--------------	-------	-----------------	------------------	-------------------	------------------------	--------------------	--------------------	--------------------

Barrel Pumps (figures are @ max 8 bar, Gear Oil SAE20 @ 20°C).

M2040	1:1	1/4	3/4	3/4	40	30	-	-
M2020	3:1	1/4	1/2	1/2	28	20	10	-
M2025	5:1	1/4	1/2	1/2	12	8	7	4

Stub Pumps for tanks, IBC's and wall mounting.

M2038	3:1	1/4	1/2	1/2	28	20	10	-
M2059	5:1	1/4	1/2	1/2	12	8	7	4
M2091	9:1	1/4	1/2	1/2	5	@ 80m 3 Ltr/min		

Gear Oil Pumps (figures are @ max 8 bar, Gear Oil SAE140 @ 20°C).

M2014	5:1	1/4	3/4	3/4	15	12	8	3
M2015	5:1	1/4	3/4	3/4	15	12	8	3

Antifreeze and Waste Oil Pumps

M2047	1:1	1/4	3/4	3/4	25	20	-	-
M2033	3:1	1/4	1/2	1/2	14	12	10	(ANTIFREEZE ONLY)

4' Tank and IBC Pumps - steel suction tube.

M2020/130	3:1	1/4	1/2	1/2	28	20	10	-
-----------	-----	-----	-----	-----	----	----	----	---



Single Air Distributor

Barrel pumps for engine oil and oils to SAE70.

M2040	1:1 For bulk transfer.
M2020	3:1 For short pipe runs and direct to hose reels.
M2025	5:1 For heavier oils and long pipe runs.



Stub Pump Kits

For tanks, IBC's and wall mounting. Pump with 1.5m suction hose, non-return valve and filter.

M2038SE	3:1 For short pipe runs and direct to hose reels. (M2038 Pump only).
M2059SE	5:1 For heavier oils and long pipe runs. (M2059 Pump only).
M2091SE	9:1 For heavy gear oil and longer pipe runs. (M2091 Pump only).
M2047SE	1:1 For antifreeze and waste oil. (M2047 Pump only).

Note: See technical data for specification and flow rates.



Air Management System

This compact system combines pressure regulator with filter, lubricator and gauge. It optimises the efficiency and the life of the pumps when in regular use, also preventing the seizure of moving parts. (Ideally should be installed next to pump.)

M5511 1/4" BSP.

M5511/1 Gauge - Air Management System



Oil Pump Kit

Oil pump with suction hose, (M5511) air management system, (M8651) 1m connection hose for outlet, (P4204) 1/2" BSP ball valve, (M7550) 8m coiled air hose.

M2038KIT 3:1 M2038SE. For barrel, tank, wall mounting.

M2059KIT 5:1 M2059SE. For barrel, tank, wall mounting.



Wall Mounting Kit Bracket

For use with stub pumps:- M2043, M2038, M2059, M2091.

M8265 Bracket only with 2" BSP ring.

Air Line Coupling 1/4" BSP

J5511/7 Male thread.

J5511/8 Female thread.



Air Line Adaptor 1/4" BSP

J5511/9 Male thread.

J5511/10 Female thread.



Air Line Hose

M7550 8m coiled. 1/4" BSP. Available colours blue, red or yellow.



Oil Dispensing Nozzle - Rigid Spout

M2118L With non drip valve and standard swivel joint. ½" BSP (F) inlet.

Oil Dispensing Nozzle - Flexible Spout

M2131L As M2118 with 90° angle tube and flexible hose.



½" BSP Flexible Hose

For use with oil dispensing nozzles.

M2190 90° with non drip nozzle.



Oil Dispensing Kit

Comprising:- M2118 nozzle, reinforced hose and ½" BSP heavy duty swivel joint fro making manoeuvrability much easier.

A5502SE 3m kit.

A5503SE 6m kit.



High Delivery Oil Gun

M2119 1" BSP, 150Ltr/min, max pressure 10 bar.

High Delivery Dispensing Kit for 1:1 Pumps

A5508SE Nozzle with 3m x 25mm bore hose. Max pressure 10 bar.



Digital Oil Dispensing Kit

Comprising:- M2926 nozzle, reinforced hose and ½" BSP heavy duty swivel joint fro making manoeuvrability much easier.

A5504RSE 3m kit. (Illustrated).

A5504R 3m reinforced hose assembly only.

A5505RSE 6m kit.

A5505R 6m reinforced hose assembly only.



Digital End Meter

Min 1Ltr/min, Max 20Ltr/min, Max. Pressure 50 bar, +/- 0.5% accuracy. Not for resale use.

M2826L With spout, 12mm non drip nozzle, ½" BSP (F) swivel inlet.

M2933L As M2826 with 90° angle tube and flexihose. (Illustrated).



Digital Pre-Set End Meter

With pre-settable meter to 99.999Ltr or 99.999 gallon. Max 20Ltr/min, Max. Pressure 50 bar, +/- 0.5% accuracy. Not for resale use.

M2941L2 With spout, 12mm non drip nozzle, ½" BSP (M) swivel inlet.



Swivel Joint ½" BSP M/F

M2106 From pump body to outlet hose and dispensing nozzle.



½" BSP High Pressure Digital Oil Meter

M2929L In line oil meter. Max pressure 50 bar, 20 Ltr/min.

M2826L/BAT Replacement Battery.

Oil Handling

Airomatic Oil Dispensing Kits



Mobile Oil Dispensing Kit

Comprising:- 1:1 ratio pump, 3m hose, M2826 digital nozzle, M7550 air hose, M5511 air management system and M4388 trolley.

M4389KIT For 205Ltr barrels. (Supplied without barrel).



Mobile Oil Dispensing Hose Reel Kit

Comprising:- 3:1 ratio pump, M2826 digital nozzle, M5511 air management system, M9016 hose reel and connecting hose M7550 air hose and M4389 trolley.

M4389KIT/H For 205Ltr barrels.

Note: Similar kits can also be supplied for grease.



Wall Mounted IBC Dispensing Pump Kit

Comprising:- 1:1 ratio pump, M2047. Complete with QR 2m hose, 2" BSP male fitting assembly, M5511 air management system, air hose, wall bracket. For Diesel or Oil.

M2047KIT Allows for quick changeover of IBC's.

Note: Delivery hoses, see previous page.



IBC Dispensing Kit

Pneumatic Dispensing Systems can be supplied for dispensing of diesel, oil, chemicals and other industrial products. We can also provide Electric Pumping Systems from 12v to 3 phase. Manual Pumps, with modifications can also be supplied to fit an IBC. Pumps can be mounted on the bracket with or without a drip tray.

Comprising:- Bracket for 1000Ltr IBC with drip tray, 15m retractable hose reel, 3:1 air operated pump, modified cap for IBC, digital dispensing gun M2826, connecting hose (pump to reel) and M5511 air management system.

Please contact us with your particular requirements.

M8210KIT For 1000Ltr IBC.



Petrol Engine Pump Kit

Powerful petrol driven 4hp motor. Special 2" BSP pump. Mounted in tubular carrying guard frame. Fuel capacity 2.5Ltr. Running time at full load 2 hours approx. For hydraulic, engine and gear oil. (Will empty a barrel of engine oil in approx. 4 mins).

J0005SE With 5m outlet hose and J3072 nozzle, 2m inlet hose, 38mm bore.

J0005SE/QR As above with quick release hoses and caps.

J0009/5SE 5m extension hose with quick release and caps.

Technical Data

Product Code	Voltage (v)	Power (kw)	Operating Pressure (bar)	Connection (BSP)	SAE	Flow Rate (SAE30) Ltr/min	Size (mm)	Weight (kg)	Suction Lift (m)
ALL HAVE IP55 PROTECTION									
J3074	110	0.5	3	3/4	90	25	330x150x210	15	1
J3075	240	1	3	3/4	90	20	320x270x160	9	2.5
J3077	12	1	8	1/2	90	30	295x165x100	10	2.5
J3075MSE	240	1	3	1/2	90	15	370x265x380	18	2.5
J3077MSE	12	1	8	1/2	90	15	370x265x380	19	2.5
J3085	240	0.5	3	3/4	90	20	330x150x210	15	1
M6135/50	240	2	20	1 in 3/4 out	90	50	420x180x280	18	1
M6312	12	0.4	3	3/8	15	10	200x150x150	8	1

Note: Valid flow rates at pump outlet.



Geared Oil Pump Kits

With self ventilated motor, continuous function, re-circulation by-pass. Comprising:- Pump, 3m outlet hose, nozzle, inlet hose. For oils and light gear oils.

- J3077 12v Pump only.
- J3077KIT 12v Pump kit with M2118 nozzle.
- J3077MSE 12v Pump kit with M2826 digital meter nozzle.
- J3074 110v Pump only. Vane Pump.
- J3075 240v Geared Pump only.
- J3075/V 240v Vane Pump, 25 L/min
- J3075KIT 240v Pump kit with M2118 nozzle. (Illustrated).
- J3075MSE 240v Pump kit with M2826 digital meter nozzle.

240v Eccentric Oil Pump

Also for waste oil.

- J3085 Pump only.

12v Pump for Light Fluids

For water, antifreeze, diesel, light oil and other fluids. (Not for use with petrol/volatile liquids). 24v also available.

- M6312 Brass chamber with viton seals. Max running time 30mins.

High Output 240v Oil Pumps

- M6135/50 As M6135 but operates at 2500 rpm.

240v Oil Barrel Pump

- J3086 Max 20/50 SAE Engine Oil, Self Priming, Inlet Suction Tube, Free-flow 60 L/min

AdBlue

On 1st October 2006 the Euro IV was introduced for new vehicles. This was an update from the EU guideline on the control of toxic fumes from heavy-duty diesel powered vehicles.

We have developed a new range of pumps and dispensing units to supply UREA/AdBlue solution AUS 32. (Urea solution DIN 70070 - NOx reducing agent). The Materials used are compatible with the solution. Our kits have differing features to satisfy varying requirements. These are detailed below.

240v AdBlue Pump Kit

Comprising:- Meter on wall/IBC mounting base with nozzle holster, 1.5m inlet hose and telescopic tube for barrel or IBC, 4m delivery hose with 19mm plastic nozzle.



J3040/ADBSE Manual ADBLUE Barrel Pump c/w TS Adapter.

J3040/ADB Barrel kit.

J3040/ADBBTK Kit with Meter (illustrated).

J3040/ADBIC IBC kit.

Specification:

- Centrifugal self-priming pump - Jet Type
- Flow rate of kit 40L/min
- Motor: 0.37kw, 230v, 50hz, single phase, self ventilated S1 continuous duty, 2800rpm, IP-44 Protection
- On/Off switch, 2m electric cable
- Inlet/outlet 1"bsp. Maximum suction length 8m.
- Maximum pressure 3.2bar
- Min/max temperature -5 ~ +60C
- Manual Meter: 1"bsp 3 digit batch, 6 digit cumulative, accuracy +/- 1%

Optional Extras and Replacement Items:

J3040/SS Stainless steel auto shut-off nozzle, 3/4" BSP, 19mm spout.

J3040/SS/SW S/S Auto Nozzle c/w S/S Swivel

J3040/NOZZ Plastic nozzle, 3/4" BSP, 19mm spout.

J3040/CAP IBC cap with 2" BSP insert.

J3040/CON CDS connector for modified IBC.

J3040/90 Elbow connector

J3040/2P Rigid Suction Tube

J3040/HOSE 4m AdBlue hose assembly, 3/4" BSP.

J3040/DM AdBlue in-line Digital Meter, 1" BSP.

3m AdBlue Hose Kit

J3040/GK 3m hose, J3040 nozzle and J2654/DIN61 Adaptor for IBC.

J3040/SSKIT 3m hose kit with J3040/SS auto nozzle for pumped systems.





Manual AdBlue Barrel Pump

Suitable for a 205 Ltr barrel
Delivery Hose Included

J3040/ADBB Manual AdBlue Barrel Pump

J3040/ADBBSE Manual AdBlue Barrel Pump c/w Adaptor



Mega Pump

J1403MP 12v-240v Pump suitable for kost drums, tanks and IBC's

Plastic Rotary Pump

Polypropylene body and tubes vanes and rotor with Vitton seals, 2" BSP Adaptor, 3 piece suction tube, 3/4" BSP inlet/outlet threads.

J1626 For AdBlue, water based solutions, petroleum products. 2" BSP Adapter

J1626/TS As above, but c/w J2654/TS adaptor for most plastic barrels



Teflon Lever Barrel Pump

J3018/TS 2" BSP c/w J2654/TS adaptor for most plastic barrels.

240v Self-Priming AdBlue Pump

Specification:

Flow: 35 Ltr/min. Bypass incorporated. Max Suction length 4m. Suction height 2.5m.
Motor: 230v, 50hz, single phase. IP-55 Protection. Maximum dry running = 3 minutes On/Off luminous switch.

Pump Kits for Barrels

Comprising: Pump, 4m outlet hose, 1m inlet hose, foot valve, strainer and nozzle

J3040/PUMP 240v AdBlue Pump only

J3040/KIT 240v AdBlue Pump kit c/w manual nozzle

J3040/KIT/A 240v AdBlue Pump kit c/w stainless steel auto shut-off nozzle



12v Self-Priming AdBlue Pump

Specification:

Flow: 32 Ltr/min. Motor 12vDC. IP-55 Protection. Continuous duty. Maximum dry running = 3 minutes.
Carrying handle. On/Off luminous switch. 1.8 metre battery cable and clips.

Pump Kits for Barrels

Comprising - Pump, 4m outlet hose, 1m inlet hose, foot valve, strainer and nozzle.

J3040/PUMP12V 12v AdBlue Pump only

J3040/12KIT 12v Pump kit c/w manual nozzle

J3040/12/KITA 120v Pump kit c/w stainless steel auto shut-off nozzle





Mega Pump

J1403MP 12v - 240v Pump suitable for most drums, tanks and IBC's

Power Source: DC 12V - 20V

Delivery Volume: Approx. 19LPM (5GMP)

Discharge hose length: Approx. 2m (6.6ft)

Applicable liquids:

Diesel, DEF (AdBlue), Water, Kerosene, Antifreeze, Windshield washer fluid, Mild detergents, Agricultural chemicals, Light oils



Quick Flow Fuel Pumps

Geared pumps for increased output. .

3:1 Quick Flow Rotary Barrel Pump

J3045/G Supplied with 1.8m dispensing hose and nozzle. Max. delivery 70Ltr/min.

Suitable for oils up to SAE 30



4:1 Quick Flow Rotary Barrel Pump

J3047 Supplied with 1.5m dispensing hose. Max. delivery 100Ltr/min.



Quick Flow Fuel Pump Kit

A1070SE/M J3047 Pump kit.

A1070SE Without meter.

J3047 Pump complete with A1003SE fuel filter, M0085 flow meter, 3mtr diesel hose and J3063 nozzle.



Hand Operated Jumbo Semi Rotary Pump

Cast iron, double acting with bronze vanes. For use with water, diesel and lubricating oils

- K0** 1/2" BSP inlet/outlet. Flow rate 12 Ltr/min.
- K1** 3/4" BSP inlet/outlet. Flow rate 22 Ltr/min.
- K2** 1" BSP inlet/outlet. Flow rate 28 Ltr/min.
- K5** 1 1/2" BSP inlet/outlet. Flow rate 50 Ltr/min.

Optional Extras: Inlet tubes, hose tails, hose and adaptors



1" Rotary Pump

250cc per revolution (approx). With 3 piece steel inlet tube with non return valve, 2" BSP adaptor, chrome plated outlet pipe.

- P0201** For 205 Ltr barrels
- P0201/48SE** For 4' tanks and IBC's with one piece inlet tube

Optional Extras:

- P0204SE** Steel suction tube or 4' tanks, fitted with non-return valve
- P0205** Locking bracket
- P1030SE** 1.5m Outlet Hose with Nozzle
- P0201/1** Extension tube and fitting



Metered Rotary Pump Kit

- P02012SE** For 20 Ltr barrels
- P02012TSE** As above but for 4' tanks and IBC's

Diesel and Fuel Handling

Air Operated and Engine Driven Pumps



Air Operated Diesel Pump

Ratio 1:1. Delivery 25Ltr/min - sustainable over long distances. Operating pressure 3 - 8 bar. Outlet 3/4" BSP. Comprising:- wall bracket, 1.5m suction hose which is open ended.

M2047SE For use with tanks, barrels etc.

Optional Extras:

Outlet hose and fittings, inlet fittings with non-return valves, filter, tube etc and air management system.



Manual Shut Off Dispensing Kit

J3063 Manual nozzle with 3m x 25mm bore hose, 3/4" BSP fittings.

A5506SE Max pressure 10 bar.

Auto Shut Off Dispensing Kit

J3070 Auto shut off nozzle with 3m x 25mm bore hose, 3/4" BSP fittings.

A5507SE Max pressure 3 bar.



Roller Vane Air Motor Kit

30Ltr/min (up to 5m) compressed air roller vane motor suitable for diesel. 1 bar outlet pressure. On/off air supply valve. 3/4" BSP ports, supplied with hose tails for 25mm bore hose and 2" boss for fitting to wall bracket.

M6557 Roller vane air motor.

Optional Extras:

M8265 Wall mounting bracket.



Roller Vane Pump Barrel Kit

Pump specification as M6557. Supplied with manual dispensing nozzle, 3m hose, inlet tube with 2" BSP adaptor and air line hose.

M6556SE To suit barrels.

Note: Filters are recommended to be installed before pump. Filters and lubricator are recommended for air supply.



Petrol Engine Pump Kit

Powerful petrol driven 4hp motor. Special 2" BSP pump. Mounted in tubular carrying guard frame. Fuel capacity 2.5Ltr. Running time at full load 2 hours approx. For diesel, hydraulic, engine and gear oil. (Will empty a barrel of diesel in approx. 2 mins). Supplied complete with 5m outlet hose and J3072 nozzle. 2m inlet hose, bore size 38mm. Max static pressure 7 bar.

J0005SE Fuel tank capacity 2.5Ltr.

J0005SE/QR As above with quick release hoses and caps. (Illustrated).

Optional Extras:

J0009/5SE 5m extension hose with quick release and caps.

J0500/IBC Adaptor converts IBC valve to 1 1/2" camlock attachment for use with J0005SE.

Diesel and Fuel Handling

Submersible and 12v & 24v Electric Pumps

Specification and Technical Data - 12 & 24v Submersible Pumps

Product Code	Voltage V	Free Flow Ltr/min	Pressure psi	Head metres	Current Maximum amps	Length cm	Diameter cm	Weight kg	Body	Cable Length with battery clips - metres	Hose dia	Outlet hose m	Seals/O rings
J0023	12	18	15	11	4.5	14.5	5.4	0.6	PP	4	½"	3	NBR/NBR
J0024	24	18	15	11	3.5	14.5	5.4	0.6	PP	4	½"	3	NBR/NBR
J3013SS	12	36	14	10	6	16.2	3.7	0.6	Acetpy	4	¾"	3	Rubber/Graphite



12 & 24 Volt Submersible Pumps

Suitable for diesel, various chemicals, fresh and dirty water. Ideally suitable for on-site diesel refuelling of contractors and agricultural plant. Efficient and easy to clean filters. Pumps can be run continuously for periods of up to 1 hour. Pumps must not be allowed to run dry. Not to be used with petrol or liquids with flash point range -20° to +80°C. Keep submerged when used with water, even when not in use.

J0023 12v pump kit. 53mm diameter.

J3013SS High output Stainless 12v pump. 38mm diameter.

J3013SS/KIT High output Stainless 12v pump kit. 38mm diameter.

J0024 24v pump kit. 53mm diameter.

Specification and Technical Data - 12 & 24v Electric Pumps

Only suitable for use with diesel. Pumps are self-priming with re-circulation by-pass. J1224 is self-priming.

Product Code	Voltage	Watts	Amps	RPM	Flow Rate of pump Ltr/min	Max Run time per hr (min) (Not dry)	Max Head (m)	Max Suction (m)	Protection (P)	Weight (kg)	Ports (BSP)
J3058	12	270	18	2800	50	CONTINUOUS	12	2.5	54	3.7	¾"
J3057/24	24	500	21	2000	85	30	-	-	55	9.9	1 ½"
J3073	24	270	10	2800	50	CONTINUOUS	12	2.5	54	3.7	¾"
J3057	12	400	35	2800	70	30	20	3.5	54	6.8	1"
J1224	12/24	192/520	16/22	1400/2200	45	30/10	12	2.5	54	7	¾"

Note: Valid flow rates with manual nozzles. Flow rates are reduced by approximately 2Lpm when using a meter. Flow rates are reduced by 14% through automatic nozzles. **Important:** Filters must be installed before pump and meter.

12 & 24 Volt Electric Pumps

Comprising:- Pump, 3m outlet hose, 1m inlet hose, manual nozzle, swivel, fittings and hose end filters for 12/24v.



J3058 12v pump only.

J3058/KIT 12v pump kit. (Illustrated).

J3058KIT/M 12v pump kit c/w meter.

J3057 12v pump only. 70 L/Min Bi Pump

J3057/24 24v 70 L/min Bi Pump.



J3073 24v pump only.

J3073/KIT 24v pump kit.

J3073KIT/M 24v pump kit c/w meter.

J1224 12/24v dual voltage pump only. Not Self-priming.

J1224/KITC 12/24v dual voltage pump kit. (Illustrated). Not Self-priming.



Diesel and Fuel Handling

110 and 240v Electric Pumps



Specification and Technical Data - 110 & 240v Electric Pumps

All diesel pumps are suitable for pumping class 'C' fuels (not petrol or liquids within flash point range -20° to +80°C). Self-priming pumps with recirculation by-pass. Built in pre-filter.

Product Code	Voltage	Watts	Amps	RPM	Flow Rate of pump Ltr/min	Max Run time per hr (min) (Not dry)	Max Head (m)	Max Suction (m)	Protection (P)	Weight (kg)	Ports (BSP)
J3076	230	550	2.8	2800	60	Continuous	20	3.5	55	7	1
J3076/110	110	550	2.8	2800	60	Continuous	20	3.5	55	7	1
J3056	230	550	4	1400	80	Continuous	20	4	55	13	1
J3036	230	550	4.5	1400	100	Continuous	25	4	55	14	1

Note: Valid flow rates with manual nozzles. Flow rates are reduced by approximately 2Lpm when using a meter. Flow rates are reduced by 14% through automatic nozzles. **Important:** Filters must be installed before pump and meter.

Electric Pump Dispensing Kits

Comprising:- Pump, 3m outlet hose, 1m inlet hose, manual nozzle, swivel, fittings (built in pre-filters).



J3076/110	110v Pump only. 60Ltr/min.
J3076/110/KIT	110v Pump kit with Manual Nozzle.
J3076/110KITA	110v Pump kit with J3070 auto shut-off nozzle.
J3076	240v Pump only. 60Ltr/min. (Illustrated).
J3076/KIT	240v Pump kit with Manual Nozzle.
J3076KIT/A	240v Pump kit with J3070 auto shut-off nozzle.
J3076KIT/MBA	240v Pump kit with auto shut-off nozzle, meter & mounting base.
J3056	240v Pump only. 80Ltr/min.
J3056KIT/A	240v Pump kit with J3070 auto shut-off nozzle.
J3056KIT/MBA	240v Pump kit with auto shut-off nozzle, meter & mounting base.(Illustrated).
J3036	240v Pump only. 100Ltr/min.
J3036KIT/A	240v Pump kit with J3070 auto shut-off nozzle.



Gravity Feed Hose Kits 1" BSP

Heavy duty hose with 90° lockable gate valve, trigger nozzle with swivel.

A1000SE 3m.

A9004SE 4m.

A9005SE 5m.

A9006SE 6m.

A9011SE 3m with polyprop nozzle.

A1009SE 3m with washable filter and locking plate. (Illustrated).



Hose only with End Fittings

A1001SE 3m.

Optional Extras:

J3061 1m x 25mm bore (order length required).*

*Can be supplied as additional lengths to A1001SE and other kits.



Metered Gravity Feed Hose Kit

A1203SE 3m c/w M0085 meter.

1 1/2" BSP Gravity Feed Hose Kit

A9103SE 3m c/w J3072 high delivery nozzle.

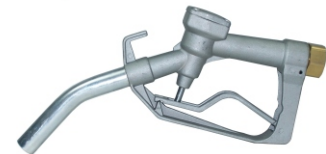

Manual Nozzles

J3063 Aluminium with 1" BSP swivel. Max flow rate 60Ltr/min.

J3079 Polyprop with 25mm swivel hose connector.

High Output Manual Nozzle

Maximum flow rate 200Ltr/min. Three lock-open trigger settings. Manufactured in aluminium. Maximum pressure 3 bar.



J3072 1 1/2" BSP female. (Illustrated with swivel - J3072SE).

Accessories:

J3072/S 1 1/2" BSP swivel for above.

Automatic Shut-Off Nozzle

Will not operate with gravity feed systems. Nozzle shuts off automatically when liquid covers the vent hole at the end of the spout. For use with diesel/gas oil. 1" BSP swivel inlet. Pumps should deliver a minimum of 13Ltr/min to activate 'shut-off' mechanism. Built in check valve, low-flow 'shut down', simple lever catch. Maximum pressure 3 bar.

J3070 60Ltr/min. 25mm O/D nozzle.

J3070/2 120Ltr/min. 30mm O/D nozzle.

J3070/MET 60Ltr/min. Automatic shut-Off Nozzle, 1" BSP Female

J3071 70Ltr/min. For unleaded petrol.

J3040/SS 60Ltr/min. Stainless steel. For AdBlue.



Accessories:

J2533 1" BSP M/F swivel joint.

J2532 3/4" BSP (M) to 1" BSP (F) swivel joint.

Diesel and Fuel Handling

Line Meters and Fuel Filters



1" BSP Mechanical Meter for Fuels, Oils etc.

Suitable for gravity, manual or electric pumps with by-pass. Not to be used with air operated pumps. Electric pumps must have bypass. Easy calibration, not for resale use.

M0085 Aluminium back.

Technical Data:

Flow Rate:	20-80Ltr/min
Calibration Accuracy:	+/- 1.0% flow volumes between 20 and 80Ltr/min
Working Pressure:	3.5 bar max (Pressure 13 bar max static)
Maximum Temperature:	65°C
Inlet/Outlet:	1" BSP
Inlet Feed and Outlet:	Vertical or horizontal.
Weight:	1.8kg
Dimensions:	140x170x200mm
Display:	4 figure plus 6 figure non-resettable totaliser in Litres



Digital Inline Meter

Aluminium body, flow range 10-100Ltr/min, Display: Batch 999.9, Cumulative 9999. Powered by 2 x AAA batteries. Max operating pressure 20.7 bar. Not for resale use.

M0087 1" female ports.

Digital Meter for Diesel & Lube

In line meter with large display.



M0089 1" BSP.

- Big Display
- Oval gear aluminium meter
- Flow rate 5-110 l/min
- Max pressure: 40 bar
- Temp: 10/+60c
- F1" Connection or flange
- Lithium Cell (approx 5 years)
- Vertical or horizontal fluid direction
- Total and partial of supplied litres
- Suitable for diesel and lubricant

Fuel Filters

See through gravity filter units: 1" BSP inlet/outlet ports. Flow rate with 600mm head 22Ltr/min, max pressure - 10.7 bar (150 psi). (Flow is restricted when filters need changing).



A1003/G 1Ltr dirt particle filter unit complete. (Illustrated).

A1003/WG 1Ltr water block filter unit complete.

J3049/G Replacement dirt particle element (10 micron).

J3049/WG Replacement water block element (15 micron particle).

J3046 1Ltr dirt particle diesel filter (clear bowl/washable filter).

J3050 Angle line filter for use with electric pumps and meters. Inlet/outlet 1" BSP.

P4506 1" BSP 'Y' strainer, female inlet/outlet.

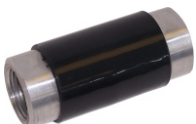

1" Breakaway Coupling

J3069 Not re-usable.



240v Explosion Proof Pump

- Output 80Ltr/min at pump
- Pressure 0.4 bar
- Ports 1" BSP and flange
- Re-circulation bypass
- Continuous run time
- Max head 20m
- Max suction 4m
- Protection IP55/thermal
- Eccentric with auto adjustable blades
- Built in pre-filter

J3056/EXP 240v Explosion proof pump



Fuel Drainer Syphon Kit

Many uses including: Transferring fuel from car to car or motorcycle to motorcycle. Extracting fluid from tanks. Extracting water from fish tanks. Pumping fuel into heaters, priming diesel fuel lines etc.

J2655 Fuel syphon kit



Automatic Shut-Off Nozzle

20mm o/d nozzle. Suitable for petrol. Supplied with 3/4 BSP swivel. 80Ltr/min max output. Nozzle shuts off automatically when liquid covers the vent hole at the end of the spout. Pumps should deliver a minimum of 13Ltr/min to activate 'shut-off' mechanism. Built in check valve, low-flow 'shut down', simple lever catch. Maximum pressure 3 bar.

J3071 70Ltr/min (shown with wall mounting bracket J3080 not included).



Fuel Retrievers

The mobile fuel retrievers are designed to facilitate the draining of vehicle fuel tanks in accordance with the Health & Safety and Work Act as laid down by the Factory Inspectorate for the safe transfer of fuel. These units allow one person to empty fuel tanks, (or other types of container), of all their contents without the fuel ever being exposed to the atmosphere. Leaded or unleaded petrol, and diesel, can be removed and replaced quickly, easily, and above all, safely. Models consist of a high output reversible rotary pump (50Ltr/min) with a 2 1/2m suction/delivery hose mounted on a robust highly manoeuvrable steel tank with wheels and castors.

F0050SE 50Ltr capacity.

F0080SE 80Ltr capacity.

Features:

Finished in safety red, safety warning labels, lockable shut-off valve, anti-flash protection in hose and pump, non spark wheels and castors, castor with brake, earthing leads, vapour transfer tube, contents sight gauge, 80 mesh strainers at pump inlet and outlet.



Manual and Syphon Pumps

Pumps in this section are not to be used with products not specified and not with products with a flash point between -20c and +80c unless specified. With telescopic suction tube, 2" BSP male thread, 300cc per stroke (approx).

Plastic Lever Barrel Pumps

J3017 Blue Polypropylene Pump Body, Viton Seals, Steel rod

Note: Suitable for use with oils, diesel, antifreeze and kerosene.

J3018 Black Pump body ryton, stainless rod (316SS), teflon seals. (Suitable for

Note: Suitable for use with acids, chemicals, water and water based liquids.



Plastic Rotary Pump

Polypropylene body and tubes, ryton vanes and rotor, viton seals, 2" BSP adaptor, 3 piece suction tube, 3/4" BSP inlet/outlet threads.

J1626 For AdBlue, water based solutions, petroleum products.*

***Note:** Check suitability with solution manufacturer.

Optional extra:

J1626/TS With J2654/TS adaptor for AdBlue plastic barrels. (Illustrated).



Piston Pumps

Suitable for cellulose thinners, industrial solvents, brake fluid, mild acid based chemicals, cleaners and detergents. Nylon suction tube and seals, steel nylon coated rod and viton seals.

J3010/25 To suit 20/25 Ltr containers.

J3010/205 To suit 205 Ltr barrels.

Note: 20/25Ltr supplied with either A or B adaptor. (Please specify or choose from the adaptors on page 18 supplied at extra cost).

A1025SE 1.5m outlet hose, on/off valve and nozzle.



Stainless Steel Lever Barrel Pump

Suitable for solvents and corrosive chemicals. 2" BSP male thread. Teflon (PTF) seals. Output 130cc per stroke.

M5495 To suit 205 Ltr barrels.



Plastic Syphon Pumps

Suitable for petrol, paraffin, diesel, insecticides, distilled water, detergents etc.

J2651 To suit 5/20 Ltr containers. Suction tube length 400mm.

J2652 To suit 25/60 Ltr containers. Suction tube length 580mm.

J2653 To suit 205 Ltr barrels. Suction tube length 850mm.



Fuel Drainer Syphon Kit

Many uses including: Transferring fuel from car to car or motorcycle to motorcycle. Extracting fluid from tanks. Extracting water from fish tanks. Pumping fuel into heaters, priming diesel fuel lines etc.

J2655 Fuel syphon kit.



Air Motor Pump for Wall Mounting

Suitable for solvents, water and aggressive liquids. 2" BSP fixing ring, aluminium body, stainless steel pump casing with PTFE seals and teflon vanes. Air supply: max 8 bar/min 2 bar. 10 Ltr/min, hose tails for 12mm bore hose, on/off air supply valve, air roller vane motor. Output regulated by adjusting air supply

M1058 3/4" BSP ports. 1/4" BSP air inlet.

Optional extras:

M8265 Zinc plated wall mounting bracket.

M1103 Stainless steel (316SS) wall mounting bracket.

Stainless Steel Barrel Pump

M1040 1:1 ratio pump for 205 Ltr barrel.

Stainless Steel Air Operated Stub Pumps

Pumps have viton seals.

M1045 1:1 ratio.

M1019 3:1 ratio.

M1022 5:1 ratio.

Accessories:

M1104/09 Rigid shaft for 205 Ltr barrel.

M1104/10 Rigid shaft for IBC.

M1105 Flexible hose for tanks with stainless steel foot valve and filter. (Illustrated).



Specification and Technical Data

Product Code	Ratio	Min/max Operating Pressure (bar)	Delivery Capacity (Ltr/min)	Max Suction Lift (m)	Shank Length (cm)	External Shank Dia. (Mm)	Outlet Ports (BSP)	Air Inlet
M1045	1:1	2-8	40	2	95	55	3/4	1/4"
M1019	3:1	2-8	14	2	95	40	1/2	1/4"
M1022	5:1	2-8	14	2	95	40	1/2	1/4"



Air Operated 1:1 Diaphragm Pumps

These pumps have a wide range of chemical resistance and are ideally suited for workshops and industrial use. The pumps can easily pass small suspended solids found in waste oil etc. They can also be used with water, antifreeze, detergents and many other fluids.

P0210 1/2" BSP. Aluminium body.

P0211 1" BSP. Aluminium body. (Illustrated).

Specification and Technical Data

Product Code	Ratio	Flow Rate (Ltr/min)	Inlet/Outlet BSP (F)	Air Inlet BSP (F)	Suction Lift (m)	Max Particle Size (Mm)	Weight (kg)	Max Air Supply Pressure (bar)
P0210	1:1	56	1/2"	1/4	8	1.6	4.54	6.9
P0211	1:1	132	1"	1/4	8	3.17	14.1	8



Electric Drill Pump Attachment

Attaches to drills with maximum 2000 rpm. Max flow rate 50 Ltr/min. Suitable for diesel, water and light oils. Made from especially strong polymers. Hose tails for 22mm ID hose.

J3055 Adapts to all drills.

12v Pump for Light Fuels

For use with water, antifreeze, diesel, light oil and other fluids. (Not for use with petrol/volatile liquids). 15 Ltr/min. Brass chamber with viton seals. Maximum running time 30 minutes. Brass tails for 14mm ID hose.



M6312 12v with 3/8" BSP ports.

M6324 24v with 3/8" BSP ports.

240v Pumps

For use with water and antifreeze.

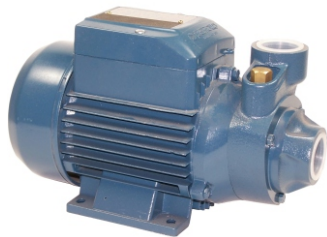

J3085 240v with 3/4" BSP ports for antifreeze. 35 Ltr/min.

M6440 240v with 1" BSP ports for water. 40 Ltr/min.

Mega Pump



J1403MP 12v - 240v Pump suitable for most drums, tanks and IBC's

Power Source: DC 12V - 20V

Delivery Volume: Approx. 19LPM (5GMP)

Discharge hose length: Approx. 2m (6.6ft)

Applicable liquids:

Diesel, DEF (AdBlue), Water, Kerosene, Antifreeze, Windshield washer fluid, Mild detergents, Agricultural chemicals, Light oils



Water Pressure Soluble Coolant Mixer

Chemical proportioner with air gap eductor. Water board approved (WRAS). System includes proportioner unit, supply tubing, foot valve assembly. Discharge tubes (1 inner and 1 outer tube) and metering ratio tip kit, hook for discharge tube, full instruction sheet - easy to install. Flow rate min 4 Ltr/min, max 14 Ltr/min, minimum water supply hose 13mm ID, minimum line pressure with water running 25 psi/1.76 bar. The metering ratio tips are selected to give the correct solution concentration.

J1116 Mixing ratio 3:1 to 350:1.



24 Ltr Air Discharge Mobile Sprayers

With level indicator, pour-off funnel, spray lance and 5m spiral hose. Suitable for use with low density lube oils, detergents and disinfectants.

M3325 24 Ltr with painted steel tank.

M3324 24 Ltr Stainless steel tank and nozzle.



Air Line Spray Gun

Suitable for releasing and light lubricating oil (non corrosive liquids).

M7315 1 Ltr capacity.



Spraying Lance

1/4" BSP female with 8m spiral hose.

M3326 Lance only.

M3326SE Lance with hose. (Illustrated).

Hose Reels

Retractable Hose Reels



Open Hose Reels - Grease

1/4" BSP inlet/outlet. 600 bar max pressure. Adjustable dispensing arm. Painted steel.

M9018 15m x 1/4" bore.

Open Hose Reels - Oil

1/2" o/d 1/2" inlet. 200 bar max pressure. Adjustable dispensing arm. Painted steel.

M9016/R 15m x 1/2" bore with 1.5M Connecting Hose.

M9021 20m x 1/2" bore.



Open Hose Reels - Diesel

M9034/15 As above with 15m 1" i/d hose.

M9034/20 As above with 20m 3/4" i/d hose.



Oil Hose Reel Kit

Comprising:- 15m hose reel, connecting hose, ball valve, 'Y' strainer and digital dispensing nozzle.

M9016KIT 15m. x 1/2" Bore

L9016KIT 15m. x 1/2" Bore



Air and Water Hose Reel

With 1.5M Connecting Hose. 1/2" Female BSP

L8630 For air and water, 1/2" BSP (f) swivel inlet 1/4" BSP outlet, 20 bar, 3/8" i/d hose.



Stainless Steel Hose Reel

L8204 For oil and water. 1/2" BSP swivel. 20 bar. 1/2" i/d hose.



Connecting Hose

For connecting reel to pump or pipework.

M8651 1.5m connecting hose for oil, air and water. 1/2" BSP.

M8652 1.5m connecting hose for grease. 1/4" BSP.

A5511R 1.5m connecting hose. 3/4" BSP.

A5512R 2m connecting hose. 1" BSP.



Drip Tray and Holding Bracket

Digital nozzle not included.

M9784 For wall mounting.



Washing Jet Lance

Max pressure 160 bar.

M6812 1/2" BSP female.



Air Blow Gun c/w 8m Spiral Hose

M7302SE 1/4" BSP female.

M7302 1/4" BSP female, gun without hose.

Storage and Trolleys



Sump Pallets

Double Barrel Plastic Sump Pallets

Plastic sump pallets ensure the safe storage and containment of spillage of liquids, and meet with EC regulations. They can be used individually or in multiples and in conjunction with barrel racking, to enable horizontal or vertical storage. Manufactured from 4mm steel plate, removable steel decking, forklift facility, powder coated for durable finish. All units have integral sumps with capacities well in excess of current environmental and COSHH regulations. Use of this equipment could result in some or all of the following benefits.

1. Satisfy fire department regulations, insurance regulations, environmental audits, COSHH and Environmental Protection Act "Duty of Care".
2. Savings on expensive absorbents and operational cleaning costs.
3. Encourage good housekeeping and a more professional workplace.



Products are designed to comply with the following acts:

- Environmental Protection Act 1990
- BS7750
- Health & Safety at Work Act 1990.
- COSHH Regulations 1986.
- Control of Pesticides Regulations 1986.
- HFL/HPG Regulations 1972.
- Petrol Consolidation Acts 1928 and 1930.
- COP 1974.
- HS(G)51

For 205Ltr barrels

M8523 2 x 205Ltr barrels.

Optional Extras for IBC's:

J2654/DIN61 Adaptor to convert Drain valve to 2" BSP. Allows the fitting of J4176/G Drum Tap

J3040/CAP Cap with 2" BSP.

J0500IBC DIN61 - 1.1/2" IBC/Camlock.

Single Skin Steel Tanks

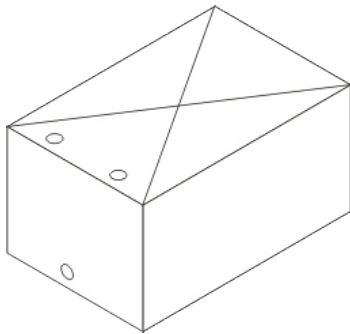

J4624/300L 300 Gallon (1363Ltr). (L) 1.83 x (W) 0.61 x (D) 1.22m.

J4624/600L 600 Gallon (2727Ltr). (L) 1.83 x (W) 1.22 x (D) 1.22m.

J4624/1000L 1000 Gallon (4546Ltr). (L) 2.44 x (W) 1.22 x (D) 1.53m.

Fully Enclosed Bunded Steel Tanks

J4645/300DS 300 Gallon. (L) 1.98 x (W) 0.76 x (D) 1.22m.

J4645/600DS 600 Gallon. (L) 1.98 x (W) 1.37 x (D) 1.22m.

J4645/1KDS 1000 Gallon. (L) 2.59 x (W) 1.37 x (D) 1.53m.

Tank Stands

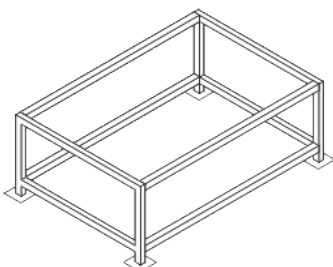

J4300/24 For 300 Gallon tanks (2' high x 5' long x 2' wide).

J4300/48 For 300 Gallon tanks (4' high x 5' long x 2' wide).

J4600/24 For 600 Gallon tanks (2' high x 5' long x 4' wide).

J4600/48 For 600 Gallon tanks (4' high x 5' long x 4' wide).



Polyethylene Barrel Drip Tray

For health and safety, holds spillages.

P0303 For 205Ltr barrel.



Drum Lift

M8221 For ease of 205Ltr barrel tilting.



Barrel Tilt & Stillage

Hard powder coat finish for 205Ltr barrels.

A1091/ASE 205 ltr drum tilt c/w wheels, handle and drain bowl

Optional Extras:

A1099/1 Retaining strap.

M8510 Single Barrel racking - no Wheels



Barrel Wrench

J2659 Universal (Not for petrol/volatile liquids).



J2659/P Plastic poly fibre.



Mobile Transporters

- Steel tanks fitted with removable drip tray.
- Ideal for the movement and dispensing of a wide range of lubricants and chemicals.
- Top tray is easily removable for access to filler caps.
- The tanks can be fitted with any of our range of lift pumps provided they are compatible with the lubricants/chemicals which are being handled (air and Manual).

A1075SE 1 x 90Ltr Tank.

A1088SE 2 x 90Ltr Tanks.

A1085SE 2 x 50Ltr Tanks (Length 510mm).

A1086SE 3 x 50Ltr Tanks (Length 740mm).

Steel Lube Tank

2" BSP standard fitting, filler opening 127mm x 89mm, hard powder coat finish.

J6090 90Ltr (Illustrated on trolley).

Optional Extra: 3/4" BSP drum taps can be fitted if required.

Storage and Trolleys

Steel Tanks, Tank Stands, Tank Kits, Clock and Sight Gauges



Tank Kit

J6003 3/4" BSP brass safety drain valve, vent fitting and filler fittings.

J6005 2" BSP cap and chain.



Clock Gauges

1.1/2" BSP male.

J4652 For 3' tanks.

J4649 For 4' tanks.

J4650 For 5' tanks.

J4651 For 6' tanks.



Barrel Level Gauge

J4654 For 205Ltr barrels. 3/4" BSP.



Push Button Sight Gauges

J4646/PB 4' x 1/2".

J4672/PB 6' x 1/2".



Dipsticks (2" BSP Caps)

J4646 4' (plated).



2 Wheeled Trolley with Support Arm

Robust trolley with 160 x 40mm wheels. Supports drum. See oil sections for suitable pumps.

A1083/SLB Fits all known 20-30Ltr containers with sliding 2" BSP bracket for pump.

A1083SE For use with J025V Valerex containers with drum support.

Optional Extras:

J025V 25Ltr "Valerex" plastic container for use with A1083SE trolley.



Two Wheeled Trolley

Steel frame, hard powder coat finish, wide wheels. Folding handles for easy transportation.

A1040 For round 20/25Ltr oil containers and 12.5kg grease kegs.

A1094 For 60Ltr oil drums and 50/60kg grease kegs.



Heavy Duty 4 Wheeled Barrel Trolley

Twin heavy duty wheels and twin castors. Brackets for securing barrel, hoses and pneumatic pumps.

M4389 For transporting 180kg/205Ltr barrels with backplate for adding hose reel.

M4388 For 180kg/205Ltr barrels without hose reel facility.

P0306 Galvanised drip tray for above, 615 x 595 x 75mm.

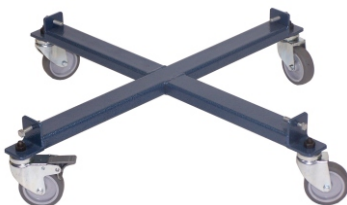

Drum Dollies

With castors and all fittings.

A1044SE For 180kg and 205Ltr oil drums. With 3" dia castors, one that is braked.



120Ltr Commercial Oil Drain Unit

With male fitting for "Clean" connection to pump away system. Clock gauge level indicator. 4-wheeled (2 rear castors). Min/max height 1190/1880mm.

M8466SE 30Ltr collection basin.



90Ltr Oil Drain Unit

Air pressure evacuation system. Can be left unattended during emptying. Max outlet hose length 2m. Min/max height 1150/1850mm.

L3181E 18Ltr round basin with 600mm dia extension bowl.



90Ltr Probe Extraction Drainers

18Ltr capacity basin with removable mesh. Six suction probes 800mm long, 2 steel (6 and 8mm), 4 flexible (5, 6, 7 and 8mm dia). Dual system - drain away or suction. Evacuation emptying by 2m hose that cannot be extended - pressure 2 bar max. Can be left unattended during emptying. Basin min/max height adjustment 1000/1700mm. Suction rate with hot oil (75°C) with 6mm probe, 15.2Ltr/min. BMW and Volkswagen adaptors.

L3194 18Ltr round basin with 600mm dia extension bowl.

L3090 Specification as L3194 without basin.

Optional Extras:

M2997 1200 x 7mm flexi probe.



80Ltr Oil Drain Unit

Air pressure evacuation system. Can be left unattended during emptying. Max outlet hose length 2m. Bowl min/max height 1160/1700mm.

M3181E 14Ltr Recovery basin.



80Ltr Pump Away Oil Drain Unit

M3181E Unit supplied with M2047 pump. Unit emptied in less than 4 mins.

M3191E 14Ltr Recovery basin.



80Ltr Probe Extraction Drainers

14Ltr capacity basin with removable mesh. Six suction probes 800mm long, 2 steel (6 and 8mm), 4 flexible (5, 5, 7 and 8mm dia). Dual system - drain away and suction. Evacuation emptying by 2m hose that cannot be extended - pressure 2 bar max. Can be left unattended during emptying. Basin min/max height adjustment 1160/1700mm. Suction time with hot oil (75°C) with 6mm probe, 15.2Ltr/min. Golf and Mercedes adaptors.

M3194 14Ltr Recovery basin. (Illustrated).

M3080 As M3194 but without recovery basin.



80Ltr Hinged Basin/Probe Extension Drainers

Dual system - drain away arm or suction.

M3182 12Ltr Basin. Other specifications as M3194.

M3180 50Ltr Basin. Other specifications as M3194.



30Ltr Probe Extraction Unit

30Ltr container with 24Ltr probe suction capacity. Supplied with six suction probes. 6-8mm steel. 5, 6, 7 and 8mm flexible.

M3024 Extraction Unit.



Drain Bowls

With 2" BSP ratchet adaptor for easy adjustment with removable mesh tray.

M3275/67 25Ltr.

M3275 25Ltr without adaptor.

M3290/67 15Ltr.

M3290 15Ltr without adaptor.



Air Operated Diaphragm Pump

See Chemicals & Fluid section for specification (page 36).

P0210 1/2" BSP Aluminium.

P0211 1" BSP Aluminium.



Plastic Drain Bowls

J2250 14Ltr Black c/w handles and pourer.

J2253 6Ltr Red c/w pourer and filter rest.



Waste Oil/Diesel/Anti-Freeze Air Operated Pump

Delivery 25Ltr/min, operating pressure 3-8 bar, outlet 3/4" BSP, supplied complete with wall bracket, 1.5m suction hose open ended.

M2047SE 1:1 Pump for use with storage and drainer systems.

Accessories: Outlet hose, end fittings.



Vacuum Pump

Supplied complete with barrel fittings, 2.5m hose and suction nozzle, (38mm dia). This pump will collect liquid borne sludge, metal chips and other debris which often clog or wear out impeller-type pumps. Additionally, the pump will not lose its prime as the liquid level drops, eliminating the need to manually bail out the bottom of the sump.

- Precision made from stainless steel.
- Compressed air powered.
- Fast - Powerful action.
- No moving parts.
- Maintenance free.
- Safe.
- Automatic shut off valve when barrel full.
- High quality.
- Fast fill - 210Ltr in 90 seconds.

J0020 For standard 205Ltr metal barrels.

Performance Chart

Pressure	Psi	60	70	80	90	100
	Cfm	5.4	5.8	6	6.3	6.5
Air Consumption	M3/min	0.15	0.16	0.17	0.18	0.18
	In.Hg	7	7.8	8.5	9.5	10.1
Vacuum	mm.Hg	178	198	216	241	257
	Gal/min	29	33	34	37	38
Water	Ltr/sec	2.2	2.5	2.6	2.8	2.9
	Gal/min	25	27	30	33	34
Oil	Ltr/sec	1.9	2.1	2.3	2.5	2.6

Caution: For best results:-
 Use filtered air 60 - 115 psi - 3/8" bore hose.
 Use only with sound, undented steel barrels.
DO NOT use with Volatile Fluids, Petrol, Kerosene etc.

Mobile Decontaminating Oil Unit

Removes suspended particles from hydraulic systems or machinery lubrication where the circulating oil must be free of impurities.

- Self priming vane pump with by-pass.
- Flow rates from 25-30 Ltr/min.
- IP55 with thermal cut out.
- Filtration capacity 10 micron.
- Complete with transparent suction and discharge hoses.

M3000 230v.

M3001 110v.

M3002 Replacement cartridge filter.



Heavy Duty Tow Bar Pins

Supplied complete with heavy duty welded chain and linch pin. Bright zinc plate and gold passivate finish.

Useable Length: 155mm
Overall Length: 185mm



J1716 16mm dia (5/8").

J1720 20mm dia (3/4").

J1722 22mm dia (7/8").

J1724 24mm dia (1").

J1728 28mm dia (1.1/8").

J1732 32mm dia (1.1/4").

Linch Pins with 'D' Ring

Ring wire dia 3.5mm. Bright zinc plate and gold passivate finish.



J0250D 6mm (1/4").

J0312D 8mm (5/16").

J0437D 11mm (7/16").

Linch Pins with 'O' Ring

Ring wire dia 3.5mm. Bright zinc plate and gold passivate finish.



J0250 6mm (1/4").

J0312 8mm (5/16").

J7500 10mm.

J0437 11mm (7/16").

J3754 54mm (below head to inside ring) Bright Zinc.

J3760 9.5mm (3/8") dia x 72mm long pin with 60mm (i/d) ring.

J3770 As above with 70mm (below head to inside ring)



Safety Linch Pin with 'O' Ring

J7502 9mm. 54mm useable length. Bright Zinc.

J3770/SAF 9.5mm. 70mm useable length. Gold passivated.



Linch Pin with Chain and 'S' Hook

72mm long with 'O' ring (70mm i/d), chain and 'S' hook.

A1011 9.5mm.

'R' Grips

Single coil 'R' grips with bright zinc plate finish.

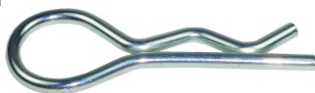

Product Code	Wire Dia.	Coil Dia.	Length
J0580	1.20mm	4mm	19mm
J0590	1.50mm	4mm	23mm
J0688	1.75mm	4mm	30mm
J0787	2.00mm	10mm	43mm
J0984	2.50mm	10mm	45mm
J1181	3.00mm	13mm	54mm
J1373	3.50mm	17mm	67mm
J1574	4.00mm	19mm	75mm
J1968	5.00mm	27mm	107mm
J2362	6.00mm	31mm	117mm
J2745	7.00mm	35mm	170mm
J3137	8.00mm	40mm	150mm

Note: J0580 is the standard brake pad 'R' grip.

Double Coil 'R' Grips with Bright Zinc Plate Finish



Product Code	Wire Dia.	Coil Dia.	Length
J0787/2D	2.00mm	9.5mm	52mm
J1574/2D	4.00mm	21mm	100mm
J1968/2D	5.00mm	26mm	130mm
J2362/2D	6.00mm	29mm	150mm
J2745/2D	7.00mm	38mm	170mm
J3137/2D	8.00mm	40mm	150mm



Brass Straight Gate Valve

- P4104 1/2"BSPTT (F/F) PN20
- P4105 3/4"BSPTT (F/F) PN20
- P4106 1"BSPTT (F/F) PN20
- P4108 1.1/2"BSPTT (F/F) PN20
- P4109 2"BSPTT (F/F) PN18

Brass Angle Gate Valve

- J3068 1"BSPTT (M/F) 90° PN20

Nickel Plated Lever Ball Valve

- J7000/4 1/2"BSPTT (F/F), not lever.
- P4204 1/2"BSPTT (F/F) PN25
- P4205 3/4"BSPTT (F/F) PN40
- P4206 1"BSPTT (F/F) PN40

Brass Swing Check Valve

- P4304 1/2"BSPTT (F/F).
- P4305 3/4"BSPTT (F/F).
- P4306 1"BSPTT (F/F).

Brass 'Y' Strainer

- P4504 1/2"BSPTT (F/F) PN20
- P4505 3/4"BSPTT (F/F) PN20
- P4506 1"BSPTT (F/F) PN20

Non-Return Valve with Filter

- P4604 1/2"BSPTT (F)
- P4605 3/4"BSPTT (F)
- P4606 1"BSPTT (F)
- P4705 3/4" Strainer only.
- P4706 1" Strainer only.

Without Filter

- P4404 1/2"BSPTT (F/F)
- P4405 3/4"BSPTT (F/F)
- P4406 1"BSPTT (F/F)

Dry Brake Couplings

- J2251/F 1/8"BSP (F)
- J2251/M 1/8"BSP (M)
- J2252/CFF 1/4"BSP (F) Chassis Filler
- J2252/CFM 1/4"BSP (M) Chassis Filler
- J2254/F 3/4"BSP (F)
- J2254/M 3/4"BSP (M)
- J2258/F 1"BSP (F)
- J2258/M 1"BSP (M)

Valves and Fittings

Hose Tails & Galvanised Fittings



Brass Hose Tail Chart



BSP									
1/4"	P2001	P2000	P2002	-	-	-	-	-	-
3/8"	P2009	P2010	-	P2011	-	-	-	-	-
1/2"	-	P2008	-	P2005	P2007	-	-	-	-
3/4"	-	-	-	P2013	P2012	P2015	-	-	-
1"	-	-	-	-	P2022	P2024	-	-	-
1.1/4"	-	-	-	-	-	-	P2028	-	-
1.1/2"	-	-	-	-	-	-	-	P2025	-
2"	-	-	-	-	-	-	-	-	P2030
Hose i/d	1/4"	3/8"	5/16"	1/2"	3/4"	1"	1.1/4"	1.1/2"	2"

Galvanised Fittings



- P1104/G** 1/2"BSPTT (M/F) Galvanised M/F 90° elbow.
- P1105/G** 3/4"BSPTT (M/F) Galvanised M/F 90° elbow.
- P1106/G** 1"BSPTT (M/F) Galvanised M/F 90° elbow.
- P1109/G** 2"BSPTT (M/F) Galvanised M/F 90° elbow.



- P1302/G** 1/4"BSPTT (F/F) Galvanised Ribbed Socket.
- P1304/G** 1/2"BSPTT (F/F) Galvanised Ribbed Socket.
- P1305/G** 3/4"BSPTT (F/F) Galvanised Ribbed Socket.
- P1306/G** 1"BSPTT (F/F) Galvanised Ribbed Socket.



- P1504/G** 1/2"BSPTT (M/M) Galvanised Hexagon Nipple.
- P1505/G** 3/4"BSPTT (M/M) Galvanised Hexagon Nipple.
- P1506/G** 1"BSPTT (M/M) Galvanised Hexagon Nipple.
- P1509/G** 2"BSPTT (M/M) Galvanised Hexagon Nipple.



- P1705/G** 1/2" (M) x 1/4" (F) BSPTT Galvanised Hexagon Bush.
- P1714/G** 1" (M) x 1/2" (F) BSPTT Galvanised Hexagon Bush.
- P1715/G** 1" (M) x 3/4" (F) BSPTT Galvanised Hexagon Bush.
- P1734/G** 2" (M) x 1" (F) BSPTT Galvanised Hexagon Bush.