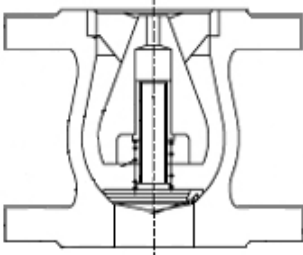
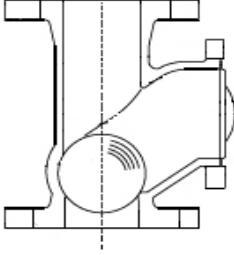
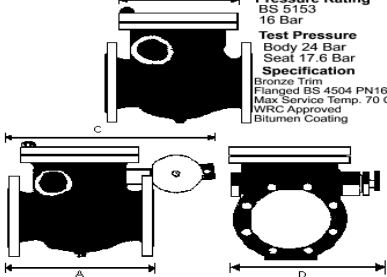
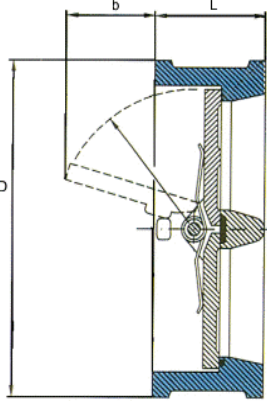
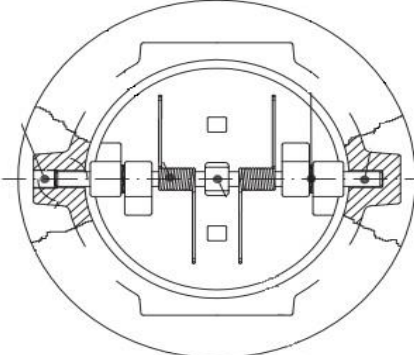

Check Valves

C.I. SPRING CHECK				BALL CHECK				DUCTILE IRON SWING CHECK VALVE								
								 <p>Pressure Rating BS 5153 16 Bar</p> <p>Test Pressure Body 24 Bar Seal 17.5 Bar</p> <p>Specification Bronze Trim Flanged BS 4504 PN16 Max Service Temp. 70 C WRC Approved Bitumen Coating</p>								
(Can be used as a foot valve and strainer)				(BSP on request)				STANDARD REF : 22M22				LEVER / WT REF: 22M23				
REF : 22M973 NEW				REF: 22M970 NEW												
SPEC: Type 973 PN16 Flgd Spring Check in S.G. Iron Buna seal. Valve & Strainer also complete as shown above Type 970 is Ball Check valve Flgd PN10. SGI Epoxy Coated body. (Blue)										SPECIFICATION: PN16 flanged valve with bronze trim for use up to 16 Bars w.n.s. (50mm to 300mm are to BS5153). Gunmetal trim & Epoxy coated Body. (Blue) temp. up to 70°C. Std Drain Plug fitted * = Non Std.						
mm		REF: 22M973 + FS			REF: 22M970				mm		REF: 22M22			REF: 22M23		
Size	FF	£ Each	Wt	£ each	Size	Hgt	Wt	£	Size	Length	Head	Length	Width	Weight	£ each	£ each
Bore	mm	Valve	Kg	complete	Bore.	mm	Kg	Each	Bore	A	B Dia	C (L/W)	D	Kg	Standard	Lever/wt
40	-	-	-	-	40	180	8	£122.00	40	-	-	-	-	-	-	-
50	100	£98.00	6	£160.00	50	200	9	£122.00	50	203	-	-	230	14	*£125.00	£160.00
65	120	£116.00	9	£175.00	65	240	12	£147.00	65	-	-	-	-	-	-	-
80	136	£145.00	11	£240.00	80	260	15	£178.00	80	241	T.B.A	T.B.A	235	20	£145.00	£175.00
100	175	£175.00	15	£290.00	100	300	20	£255.00	100	292	T.B.A	T.B.A	268	26	£185.00	£210.00
125	200	£299.00	24	£355.00	125	350	30	£383.00	125	330	-	-	300	-	-	£375.00
150	234	£375.00	31	£580.00	150	400	38	£485.00	150	356	T.B.A	T.B.A	313	50	£300.00	£375.00
200	300	£805.00	48	£865.00	200	500	70	£985.00	200	495	T.B.A	T.B.A	378	96	£665.00	£730.00
250	370	£1,155.00	82	£1,190.00	250	700	180	£1,830.00	250	622	T.B.A	T.B.A	493	155	£835.00	£970.00
300	(3" Hose Tail Type = £80)				300	700	180	£2,457.00	300	698	T.B.A	T.B.A	535	215	£1,185.00	£1,400.00
350	(4" Hose Tail Type = £90)				350	800	290	£4,065.00	350	640	*(PN16)	-	-	-	TBA	£3,285.00
400	(6" Hose Tail Type = £165)				400	900	420	£7,495.00	400	695	*(PN16)	-	-	-	TBA	£4,445.00
Type 22M973 - Epoxy Coated with Buna Seal + Galv. Strainer									450	750	T.B.A	-	-	-	*(PN10)	-
Larger Foot Valves & Strainers per special order to 600mm									500	820	T.B.A	-	-	-	*	-

Dual Plate Check Valve						
Cast Iron Body (GG25) Epoxy Coated. SS302/4 Spring and Pin. SS304 plates. Wafer fitting between Flanges PN16 to 400mm and PN10 upwards 450mm to 600mm. The Valve must be used with spindle in vertical position on horizontal lines (Valve can be used in vertical lines also.) Seals are EPDM. All Dual Plate valves may seep.						
Size Bore	F to F	Weight Kg	REF : 22M960		22M961	
			Outside	Cast Iron	SS CF8M	
	m m		Dia mm	Price £	Price £	
40mm	43	1	94	£57.00	TBA	
50mm	43	2	109	£57.00	£179.00	
65mm	46	3	129	£65.00	£225.00	
80mm	64	4	144	£70.00	£305.00	
100mm	64	5	164	£90.00	£357.00	
125mm	70	7	194	£130.00	£540.00	
150mm	76	8	220	£140.00	£785.00	
200mm	89	16	275	£220.00	£1,305.00	
250mm	114	27	330	£365.00	£2,710.00	
300mm	114	34	380	£470.00	£3,355.00	
350mm	127	53	440	£805.00	TBA	
400mm	140	70	491	£1,035.00	TBA	
450mm	152	100	541	£2,055.00	TBA	
500mm	152	120	596	£2,300.00	TBA	
600mm	178	180	698	£3,155.00	TBA	

Larger Sizes also.

AIR VALVES SINGLE / DOUBLE TYPE CAN ALSO BE SUPPLIED TO ORDER

Notes :

PLEASE NOTE : Prices subject to change without prior notice.

updated: 01/09/2016

Everyvalve Ltd | 19 STATION CLOSE | POTTERS BAR | HERTS | EN6 1TL | TEL : 0044(0)1707642018 | FAX : 0044(0)1707646340 | http://www.everyvalve.com | sales@everyvalve.com