

Everyvalve Ltd

19 Station Close, Potters Bar, Herts. EN6 1TL

tel: 01707 642018

fax: 01707 646340

www.everyvalve.com

e-mail: sales@everyvalve.com

GATE VALVE

WRAS
APPROVED
PRODUCT



figure 3000

Metal seat wedge gate valve used for pipeline isolation.

Suitable for water, wastewater and sewage applications.

Features

- Unique lightweight ductile iron design
- WRAS listed non-metallic components
- Durable fusion bonded epoxy coated
- Stem seals replaceable under pressure
- Clockwise closing spindle as standard, clockwise opening on request
- Corrosion resistant construction
- 100% full bore
- Drilling bosses and drain plug as standard
- Integral feet to facilitate safe storage
- Robust low maintenance design suitable for buried service

Options

- Handwheel or stem cap operation
- Actuation: electric or pneumatic
- Gearboxes: bevel or spur
- Position indicator
- Locking device
- By-pass
- Extension spindles and tee keys
- Alternative flange drillings

GATE VALVE

figure 3000

ACCESSORIES	
Stem Cap / Handwheel	Extension Spindle / T Key
Position Indicator	Gearbox
Locking Device	By-pass
ISO Mounting Flange	Chainwheel

DIMENSIONS								
DN	A	B	C	D	E	Approximate Weight (kg)		WRAS Approval
						Handwheel	Stem Cap	
50	178	165	282	312	180	23	21	✓
65	190	185	313	343	180	24	22	
80	203	200	398	428	205	26	24	✓
100	229	220	424	454	205	31	29	✓
125	254	250	445	475	250	41	39	
150	267	285	525	556	280	58	55	✓
200	292	340	638	668	320	87	82	
250	330	405	740	770	360	131	125	
300	356	460	840	870	450	186	177	

Larger sizes available upon request. Dimensions in mm.

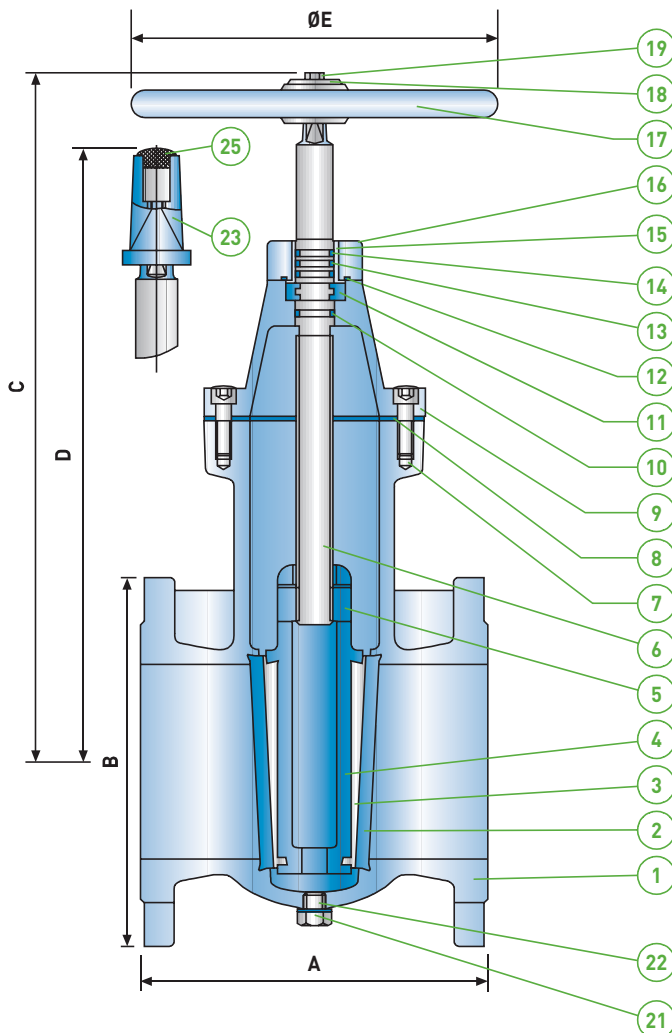

TECHNICAL SPECIFICATION	
Standard:	BS 5163 Pt. 1 & 2:2004 & EN 1171:2002
Range:	DN50 - DN300
Flanges & Drillings: Alternatives:	BS EN 1092-2:1987 Table 9 (PN16) BS EN 1092-2:1987 Table 8 (PN10) BS10 Table D or E
Maximum Working Pressure:	16 Bar
Hydrostatic Pressure Tests:	Seat: 1.1 x PN (17.6 Bar) Body: 1.5 x PN (24.0 Bar)
Temperature Range:	-10°C to 70°C Insulate at 0°C and below
Coating:	Blue fusion bonded epoxy (WRAS listed)
Face-to-Face Dimensions:	BS EN 558-1:1986 Table 3, Basic Series 3

MATERIAL SPECIFICATION			
Item	Item Name	Material	Specification
1	Body	Ductile Iron	BS EN 1563 Gr 500/7
2	Body Seat Ring	Copper Alloy	BS EN 1982
3	Wedge Seat Ring	Copper Alloy	BS EN 1982
4	Wedge	Ductile Iron	BS EN 1563 Gr 500/7
5	Stem Nut	Copper Alloy	BS EN 1982
6	Stem	Stainless Steel	BS EN 10088
7	Bolt	BZP Steel	BS 3692 Gr 8.8
8	Body Gasket	EPDM	WRAS Listed
9	Bonnet	Ductile Iron	BS EN 1563 Gr 500/7
10	'O' Ring	EPDM	WRAS Listed
11	Thrust Collar	Copper Alloy	BS EN 1982
12	'O' Ring	EPDM	WRAS Listed
13	'O' Ring	EPDM	WRAS Listed
14	Dust Seal	EPDM	WRAS Listed
15	Bush	Copper Alloy	BS EN 1982
16	Seal Housing	Ductile Iron	BS EN 1563 Gr 500/7
17	Handwheel	Ductile Iron	BS EN 1563 Gr 500/7
18	Washer	Stainless Steel	BS EN 10088
19	Bolt	Stainless Steel	BS EN 10088
20*	Sealing Housing Bolt	BZP Steel	BS 3692 Gr 8.8
21	Drain Plug	Stainless Steel	BS EN 10088
22	Gasket	PTFE	WRAS Listed
23	Stem Cap	Ductile Iron	BS EN 1563 Gr 500/7
24*	Stem Cap Bolt	Stainless Steel	BS EN 10088
25	Grommet	EPDM	-

*Seal Housing Bolts and Stem Cap Bolt not shown.