

CEIBRIT

# Rainscreen Cladding



**Your choice.** In addition to the range of colours and shades, Cembrit cladding boards are available in four compositions, each with distinctive performance and characteristics.

## Cembrit Cover

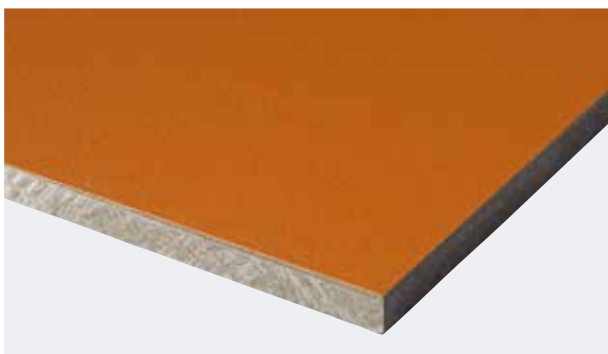

Cembrit Cover is the ideal solution if you prefer the strongest colours and bolder design statements. The natural grey fibre-cement core is completely covered by a layer of water-based acrylic paint, with 26 standard Cembrit colours and more than 2000 NCS® colours to choose from.

## Cembrit Patina

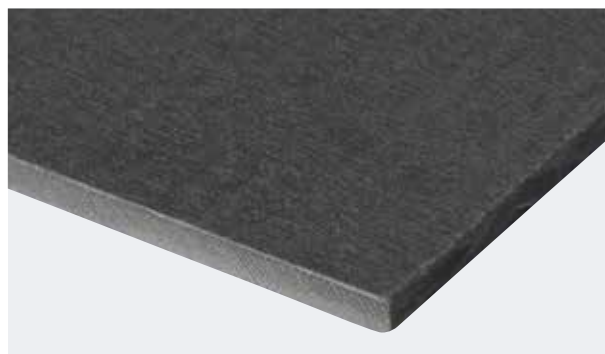

Cembrit Patina has a natural, textured surface. You can see the fibre and natural characteristics of the raw materials, and you can see and feel the sanding lines on the surface. As the seasons change and the years pass, the natural ageing of the fibre cement leaves subtle traces on the surface, and the cladding will gradually acquire a distinctive patina.

## Cembrit Solid

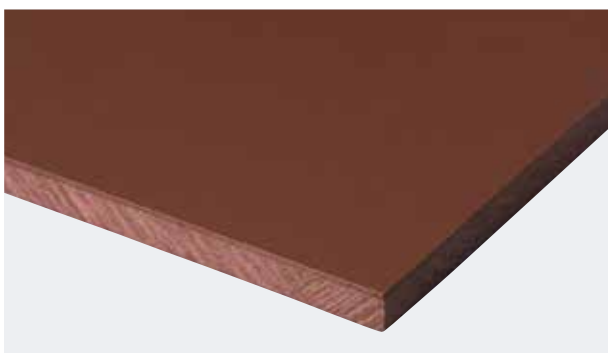

The special thing about Cembrit Solid boards is that they're the same colour all the way through. Each of the core colours is matched with a full-coverage painted surface in vibrant yet resilient colours. This means if you choose Cembrit Solid boards to provide a façade with a particular colour, every board will feature that colour on every surface and edge, and with the same colour on the edges of any cut-outs or drilled holes.

## Cembrit Transparent

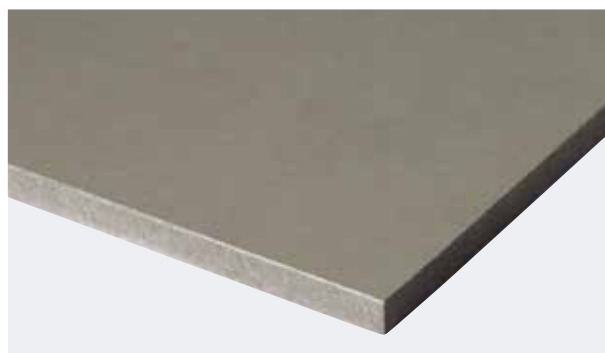

Cembrit Transparent cladding boards combine the textured nuances and natural characteristics of the base board with a long lasting performance of the transparent top coat. The colour added to the fibre cement reveals and highlights the fibres and other raw materials that provide its strength and character. The extremely durable transparent coating then protects the board and ensures a smooth surface with a long service life.



## The cutting advantage

The edges of cladding boards play a big role in the visual impact of the product, and the overall sense of quality. The edge-on impression can often be a key design feature, or decisive for the big-picture impression.

Cembrit manufacturing technology now includes advanced cutting equipment that we've adapted from its conventional use in modern furniture production, making it possible to combine board cutting with trimming and sanding the edges.

This gives a perfect, consistent finish that you can rely on to look attractive from all angles, with the big added benefits of greater durability. Another big advantage is that the bevelled edges help prevent damage to the paint during installation.

Cembrit is the only manufacturer of fibre-cement products with the technology to automatically seal the edge of boards while cutting.





#### TYPE OF BOARD

The letter that the product ID starts with describes the distinctive feature of that particular type of board.

Patina (P)      Solid (S)  
Cover (C)      Transparent (T)

#### COLOUR GROUP

The first number in the product ID describes the colour group:

**0** Grey      **5** Yellow  
**1** Black      **6** Green  
**2** White      **7** Blue  
**3** Red

Each colour group ranges from soft, delicate, light tones to intense, saturated, dark colours, graduated over 61 standard colours.

Cembrit standard colours are specially selected to suit European architectural styles and building traditions.

#### SHADES OF SUCCESS

The second number in the product ID describes the shade of the surface.

The lightest shade of a colour is defined by the number 0, while the deepest and most intense surface shade bears the number 9.

#### BASE COLOUR

The third number in the product ID describes the core colour – the colour that's visible on the edges, or if you make inserts or holes. Sometimes this is an elegant match for the front surface of the board. And sometimes it isn't ever seen, or any colour difference simply doesn't matter.

**0**

is your perfect grey

**P 050**



**1**

is your new black

**T 171**



**2**

is your white dream

**S 212**



# 3

is your  
red hot  
choice

**C 360**



# 5

is your  
code  
yellow

**C 570**

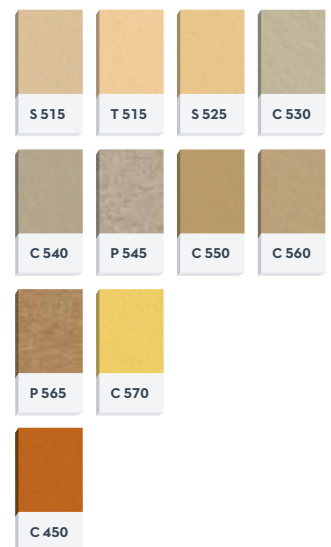



6

is your green tomorrow

P 626



7

is your favourite blue

C 770

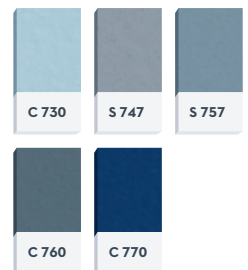

# Essentials for installing rainscreen cladding

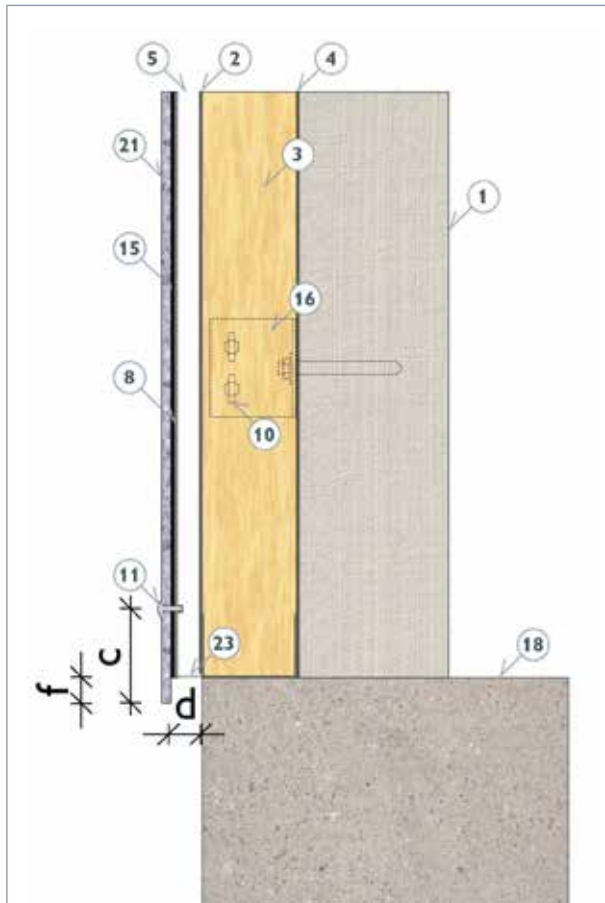

## Vertical cross section foundation

- 1 Structural frame/load bearing wall
- 2 Sheathing
- 3 Insulation
- 4 Vapour Control Layer
- 5 Air gap min 25 mm
- 8 EPDM underlay 90 mm
- 10 Fixing point profile/bracket
- 11 Rivet SS 4.0 x 19/14
- 15 Aluminium profile
- 16 Aluminium frame system
- 18 Foundation
- 21 Facade board
- 23 Insect mesh
- c Corner distance min 100 mm
- d Ventilation inlet min 200 cm<sup>2</sup>/m
- f Overhang ca 30 mm

Further information on specific details, secret fix and non-standard applications are available in Cembrit “Installation and Design Guides”.

The most popular rainscreen cladding systems in the UK incorporate aluminium framework behind the cladding. This comprises brackets fixed to the permanent structure onto which are fixed T or L section aluminium rails which support the cladding.

The system is designed to provide ventilation behind the decorative rainscreen cladding as well as an internal skin or sheathing, insulation and a vapour control layer in front of the permanent structure.

The air gap between the rainscreen cladding and the sheathing must be a minimum of 25mm with a cross section of 200cm<sup>2</sup>/m. Insects should be prevented from entering this gap by means of meshes.



The decorative cladding boards are fixed to the aluminium rails with (generally, colour matched) rivets.

Decorative claddings are generally fixed portrait (vertically) onto vertical aluminium rails. The rainscreen assembly is essentially a “floating” system in which the decorative cladding can move in reaction to wind load and temperature. It requires a permanent central fixing and the possibility of movement, expansion and contraction at other fixings and around the edges of the board.

The fixing holes in the boards must be pre-drilled, oversized and must be perfectly in line with the fixing hole in the aluminium rail. Therefore a centralising tool must be used to drill the fixing hole in the aluminium hole.



The first rivet takes the weight of the board. It is placed centrally. A spacer is used to ensure a fixed point. All other rivets are inserted using a stand off-head tool to allow movement. After installing the central rivet install rivets above and then below the central fixing.



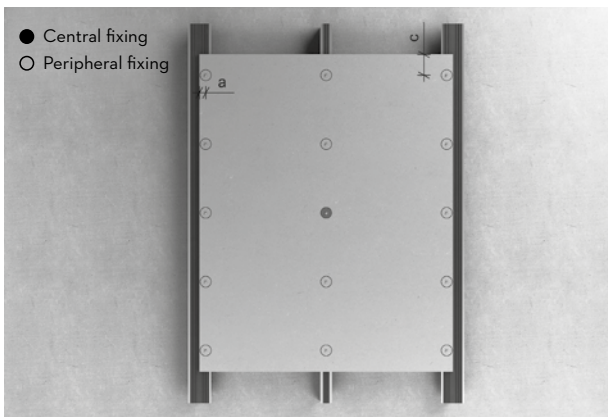

The aluminium rails should be a minimum of 3m long. The butt joints of the rail should coincide with butt joints in the decorative cladding boards. The boards should never cross the joints in the rails as this will prevent movement in the system.



Rivets should not be positioned too close to corners or board edges due to the risk of cracking. Fixing centres will vary according to local wind loadings. The minimum distance for fixing holes in corners is 100mm from the horizontal edge, 40mm from the vertical edge.

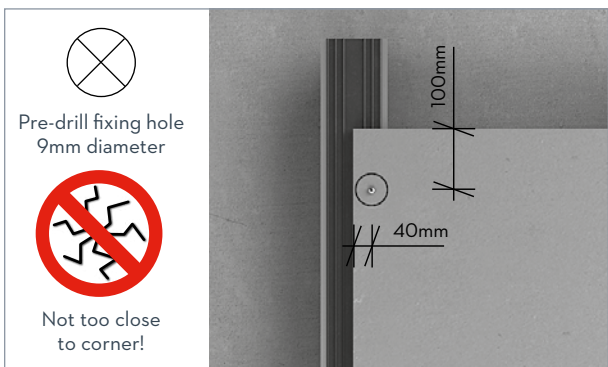

Decorative rainscreen claddings are high performance external façade panels. All buildings will have openings, mitres, internal and external corners and perimeters which do not correspond exactly to board dimensions. Incorrect cutting, damage, poor handling can be costly and time consuming. Cembrit boards are only available from specialist cutter merchants who have the equipment, expertise and software to supply the most economically dimensioned panels. Contact Cembrit for our nearest cutter merchant.

### Secret fix

Cembrit boards can be adhesive fixed to a sub structure of aluminium or planed, impregnated wood. Note! The adhesive supplier's recommendations must be followed while using this type of installation. For further information please contact your local Cembrit representative

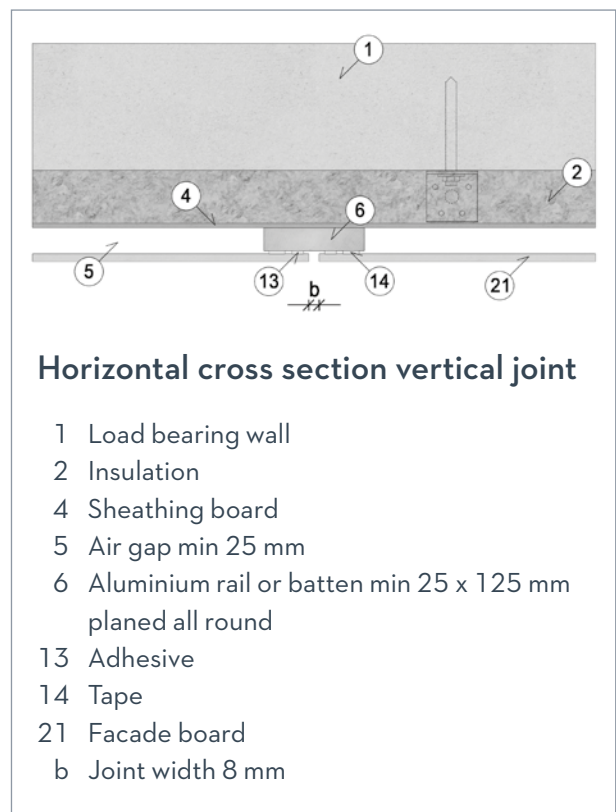

# Accessories

Cembrit screws for fixing facade boards are made of stainless steel for achieving the highest corrosion resistance. Mushroom head wood screws 4.5 x 36/4 1 are used for wooden structural supports.



The screws have a sharp point and a fast cutting thread which secures a firm fixing with a high pull out value.



An alternative solution for wooden sub-constructions is the wing screw 4.9 x 38 which is equipped with a drill bit and therefore needs no pre-drilling.



For steel sub-constructions stainless self drilling and thread cutting screws 4.8 x 25 are used. Drilling capacity 1.5-2.5 mm



All screws are delivered plain or in the same colour as the facade boards, and with a Torx 20 bit included ready to use.



On aluminium sub-constructions rivets are most commonly used. Cembrit rivets 4.0 x 19/K14 feature an aluminium body with a stainless steel mandrel. At central fixings sleeve is used to prevent movement of the board.

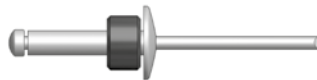

In order to allow the boards to move freely at peripheral fixing points when influenced by moisture and temperature changes, a stand-off head must be used ensuring a small space between the board and the rivet head. A stand off head is not required at the central fixing point.



For securing the above mentioned free movement of the boards it is of great importance that the drill hole in the aluminium sub-contruction and the drill hole in the Cembonit board are concentric. This is ensured by using an assisting tool.



4.1 mm HSS drill for rivets in aluminium profiles.



Special drill bit like TCT Drill (7-8-9 mm) from Irwin Tools for predrilling in the façade boards.

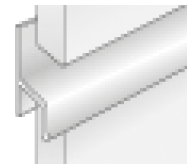
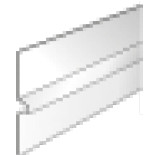

Aluminium interfaces, joints and internal and external corners are available.

# Fixing Details

Thickness mm	Board width mm	Wind load kN/m <sup>2</sup>	Fixing hole location on board edges, see diagram on page 9		Maximum fixing centres for vertical supports mm	Max fixing distance along board edges mm	Maximum fixing distance in centre of boards mm
			a mm	c mm			
8	1200	1.5	30	70	600	600	600
8	1200	1.75	30	70	600	600	600
8	1200	2.00	30	70	400	600	600
8	1200	2.25	30	70	400	600	600
8	1200	2.5	30	70	400	600	600
8	1200	2.75	30	70	400	600	600
8	1200	3.00	30	70	400	500	500
8	1200	3.25	30	70	400	500	500
8	1200	3.50	30	70	400	400	400

Sub-construction	Drill hole in board mm	Drill Holes	
		Drill hole in sub construction mm	
Wood	Ø7	-	
Aluminium	Ø9	Ø4.1 (rivet 4.0mm)	
Steel	Ø8	-	

# Specifications

	Patina (Cembonit)		Cover (Metro)	
Thickness (mm):	8	8	8	8
Dimensions (mm):	1200 x 2500	1200 x 3050	1250 x 2500	1250 x 3050
Weight per sheet (Kg):	40.8	49.8	49	59.9
Weight per m <sup>2</sup> (Kg):	13.6	13.6	15.7	15.7
Quantity sheets per pallet:	40	35	40	30
Fire rating:	Class 0 to BS 476 part 6, Class 1 to BS 476 part 7		EN 13501-1:2002:E reaction to fire, class A2-s1,d0	
Accreditation:	EN 12467:2004 NT A41, EN 1350-1:2002 A2 s1-d0		EN 12467:2004:E NT A41	

	Solid (Zenit)		Transparent (True)
Thickness (mm):	8	8	8
Dimensions (mm):	1250 x 2500	1250 x 3050	1250 x 3050
Weight per sheet (Kg):	49	59.9	59.9
Weight per m <sup>2</sup> (Kg):	15.7	15.7	15.7
Quantity sheets per pallet:	40	30	30
Fire rating:	EN 13501-1:2002:E reaction to fire, class A2-s1,d0		EN 13501-1:2002:E reaction to fire, class A2-s1,d0
Accreditation:	EN 12467:2004:E NT A41		EN 12467:2004:E NT A41

# CEMBRIT

Cembrit Claddings & Building Boards Division  
Unit 2  
Foxbridge Way  
Normanton Industrial Estate  
Normanton, Nr Leeds  
West Yorkshire WF6 1TN  
Tel: 01924 890890  
Fax: 01924 897487

Head Office  
Cembrit Ltd  
Studio 39  
Thames Innovation Centre  
2 Veridion Way, Erith  
Kent DA18 4AL  
Tel: 020 8301 8900  
Fax: 020 8301 8901  
[info@cembrit.co.uk](mailto:info@cembrit.co.uk)

[cembrit.co.uk](http://cembrit.co.uk)