

# CEMBRIT

# Installation

## Cembrit Cover, Solid and Transparent

### Table of Contents

Product Information	2
Product Datasheet	5
Accessories	6
Installation on wooden sub-cunstruction	8
Installation on aluminium sub-construction	15
Installation on steel sub-construction	22
Installation by bonding	29
Weatherboards	29
Storing, Handling and Processing	33
Maintenance	36



# Product Information



## Product Information

Cembrit fibre-cement is a modern building material made from natural and environmentally friendly raw materials. The technology has been developed by Cembrit, holding more than 80 years of experience within the manufacture of fibre cement. Our wide experience ensures a sustainable product which has accumulated all the advantages of fibre cement.

## Quality:

Cembrit product specifications and classifications comply with EN 12467:2004 and 13501-1:2002.

The facade range:

- is manufactured in accordance with the quality management system ISO 9001:2008 and the environmental management system ISO 14001:2004
- holds an Environmental Product Declaration EPD-CEM-2012111-E according to ISO 14025
- complies with the provisions set out in the Construction Products Regulation (EU) No. 305/2011
- complies with the CE Declaration of Performance

The Ufacade range can be used in all self-ventilated light weight facade constructions. Featuring properties such as non-combustibility, sound and weather insulation as well as high impact strength, Cembrit fibre-cement boards are the ideal facade material.

The fibre-cement boards are produced from a composition of Portland cement, mineral fillers, cellulose and plastic fibres.

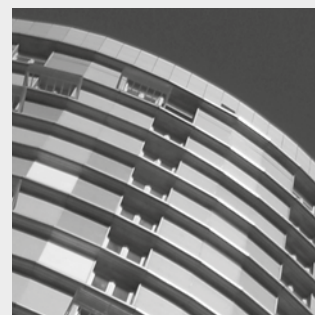

## Ventilated facade, principle

- 1 Load bearing wall
- 2 Insulation
- 4 EPDM underlay (only on wood sub structures)
- 5 Air gap min 25 mm
- 6 Aluminium frame system
- 7 Rivet 4.0 x 20 K14 or screw
- 21 Facade board

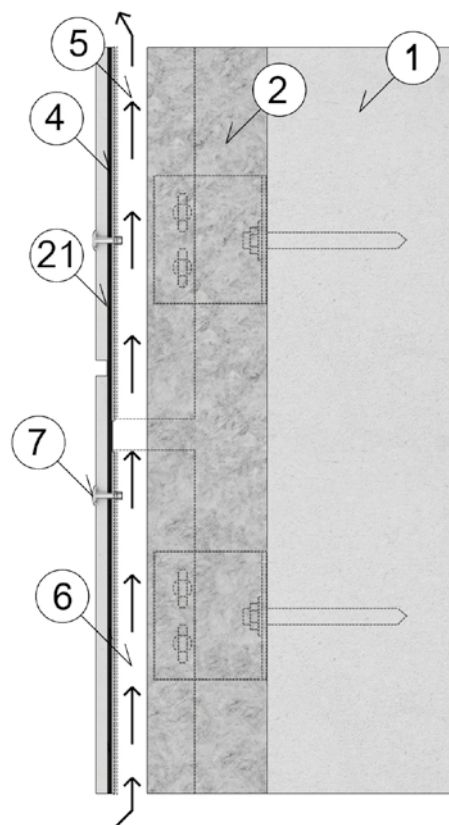

### Surface appearance and colours

Because of its natural composition, variations in appearance may occur in the individual boards and from board to board. Please note that this does not have any negative effect upon the durability of the boards. In order to minimise differences, it is recommended that boards intended for the same facade are taken from the same batch as minor variations may occur from one production lot to another.

Over time colours may change as a consequence of the impact from UV light and the environment in general. Cembrit boards will, however, maintain their colour and gloss level to a high extent. According to the European standard EN 20105 Test

for colour fastness, Part AO2 Grey Scale for assessing change in colour, most colours will maintain grade 4-5 after a QUV test of 3000 hours, which in oral terms means that changes are hardly visible.

### Preferred application areas are:

- Self-ventilating facades
- Attics
- Weatherboards
- Window elements
- Eaves and roof edges
- Balconies
- Prefabricated facade elements

### Self-ventilating facades

The self-ventilating facade is a physical construction which contributes to reducing temperature variations in the wall throughout the year. Sunlight is reflected in the summertime, and the dry insulation reduces heat loss in cold seasons. At the same time the construction ventilates interior condensation.

The boards can be installed with open horizontal joints, with joint profiles or as a weather boarding.

The sub-construction is anchored to the inner wall and transfers the load of the facade boards to the main construction.

Rating	Character of Change
5	No change
4	Insignificant change of depth in colour. Hardly visible
3	Loss in depth of colour. Visible
2	Increasing change
1	Major change

## Dimensions

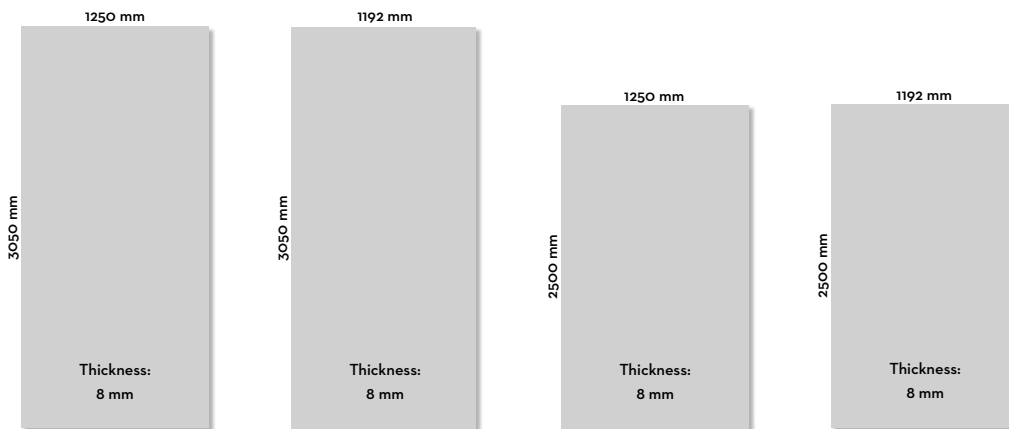

### Finishing

If boards are cut to size on site, cutting edges should be bevelled with sand paper.  
After trimming, the edges must be sealed with Cembrit Universal Edge Sealer included in the delivery. Please see instructions on page 38.



## Product Datasheet for Cembrit Transparent, Cembrit Cover and Cembrit Solid

Property	Unit	Value Cembit Transparent	Value Cembit Cover	Value Cembit Solid
<b>Dimension after trimming</b>				
Width	mm	1192 / 1220	1192 / 1220	1192 / 1220
Length	mm	2500 / 3040	2500 / 3050	2500 / 3050
Thickness	mm	8.0	8.0	8.0
<b>Physical properties</b>				
Density, dry	Kg/m <sup>3</sup>	≥1550	≥1500	≥1500
Weight	Kg/m <sup>2</sup>	~15.7	~15.7	~15.7
<b>Mechanical properties</b>				
Bending modulus of elasticity				
Dry E-module with grain	GPa	13	13	13
<b>Bending strength</b>				
Wet with grain	MPa	18	18	18
<b>Thermal properties</b>				
Heat conductivity	W/m °C	0.5	0.5	0.5
Coefficient of thermal expansion	mm/m °C	0.01	0.01	0.01
Temperature range	°C	Max. 80	Max. 80	Max. 80
Frost resistance	Cycles	>100	>100	>100
<b>Hygrothermal properties</b>				
Moisture movement (50-90% RH)	mm/m	1.5	1.5	1.5
<b>Tolerances (ref. EN 12467)</b>				
Thickness	%	±10	±10	±10
Length	mm	±5	±5	±5
Width	mm	±2	±2	±2
<b>Other properties</b>				
pH surface		11		
Category. Class	EN 12467	NT A4 I	NT A4 I	NT A4 I
Fire rating	EN 13501	A2-s1, d0	A2-s1, d0	A2-s1, d0

Cembit complies with the relevant provisions of the Construction Products Regulation (EU) No. 305/2011

# Accessories

Cembrit screws for fixing facade boards are made of stainless steel for achieving the highest corrosion resistance. Mushroom head wood screws 4.5 x 36/41 are used for wooden sub-constructions. The screws have a sharp point and a fast cutting thread which ensure firm fixing with a high pull-out value.



Furthermore, a washer is fixed on the tip of the screw to centralise it and to minimise penetration of water into the screw hole.



An alternative solution for wooden sub-constructions is the wing screw 4.9 x 38 which is equipped with a cutting bit and therefore requires no pre-drilling.



For steel sub-constructions with profiles  $\geq 0.5$  use Cembrit stainless steel self drilling and thread cutting screw 4.8 x 29 #1 with drilling capacity 0.5-1.5 mm. As an alternative use Cembrit stainless steel rivets 4.8x19 K14.



All screws are delivered in their natural colour or powder painted in the same colour as the facade boards, and with a screw bit included ready to use.



On aluminium sub-constructions rivets are most commonly used. Cembrit rivets 4.0 x 20 K14 feature an aluminium body with a stainless steel mandrel. At fix-points, a sleeve is used to prevent movement of the board.

In order to allow the boards to move freely in sliding points when influenced by moisture and temperature changes, a stand-off head must be used ensuring a small space between the board and the rivet head. Drill holes are made correctly with the centering device.



For securing the above mentioned free movement of the boards, it is of great importance that the drill hole in the aluminium sub-construction and the drill hole in the Cembrit board are concentric. This is ensured by using an assisting tool:



4.1 mm HSS drill for rivets in aluminium profiles (4.0 x 20 K14).  
4.9 mm HSS drill for rivets in steel profiles (4.8 x 19 K14).



Special drill bit such as TCT Drill (7-8-9 mm) from Irwin Tools for pre-drilling in the facade boards.

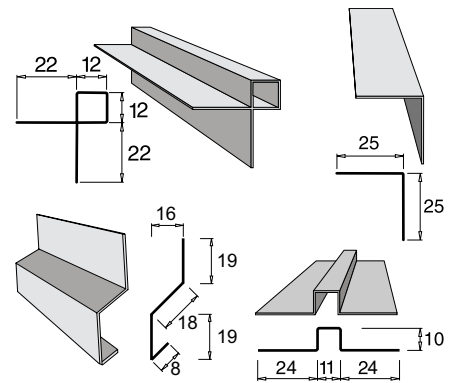

Aluminium corner profiles for internal and external corners are available on request.

Cembrit EPDM rubber underlay (3x90 mm and 3 x 30 mm) should always be placed under the Cembrit boards using mechanical fixing.





Cembrit boards can be fixed by gluing them to a sub-structure of planed impregnated wood or aluminium.

**Note!** The glue supplier's recommendations must be followed in this type of installation. For further information, please contact your local Cembrit representative.

# Sub-constructions and Supports

## Basic sub-constructions

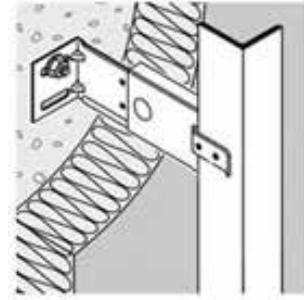
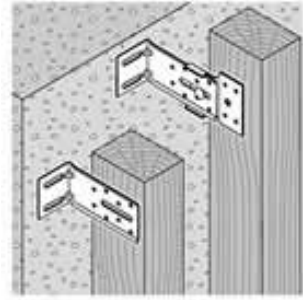
Wooden sub-construction	Metal sub-construction		Combined sub-construction
	Aluminium sub-construction	Steel sub-construction	
			

**Important!** Cladding with Cembrit products must always be carried out as a ventilated facade with min 25 mm distance between the cladding and the rear lining (insulation material). However, in special situations (e.g. high rise buildings), local regulations may demand a larger ventilation gap. Inlet and outlet openings must have a cross section of least 200 cm<sup>2</sup>/m.

## Fixing Details

### Vertical board orientation

Installation on wood, vertical sub-construction

Max dimensions 8 x 1250 x 2500/3050 mm

Drill hole in the boards: Ø8

Max support distance	Max fixing distance	Edge distance	Corner distance
k mm	h, g mm	a mm	c mm
400-600**	350-600**	25-150	100-150*

\*Overhang e.g. windows or foundations max 200 mm

\*\*Depending on windload.

Contact Cembrit for further details.

### Front view vertical orientation

The installer is responsible for establishing a plane and strong sub-construction able to obtain the loads appearing on the actual facade and observing the fixing distances described in this manual.



### Horizontal board orientation

Installation on wood, vertical sub-construction

Max dimensions 8 x 1250 x 2500/3050 mm

Drill hole in the boards: Ø8

Max support distance	Max fixing distance	Edge distance	Corner distance
k mm	h, g mm	a mm	c mm
400-600**	350-600**	25-150	100-150*

\*Overhang e.g. windows or foundations max 200 mm

\*\*Depending on windload.

Contact Cembrit for further details.

### Front view horizontal orientation

Facade boards are normally installed in a vertical position on a vertical sub-structure. It is however possible to install the boards in a horizontal position. The guidelines for fixing are identical, which means the edge distances, corner distances etc. follow the sub-structure.





# Screws on wooden sub-constructions

## Fixing details screws on wood

### Horizontal cross section vertical joint

- 1 Load bearing wall
- 2 Insulation
- 4 Wind break
- 5 Air gap min 25 mm
- 6 Batten min 25 x 125 mm
- 8 EPDM underlay 90 mm
- 9 Facade screw 4.5 x 36/41
- 21 Facade board
- a Edge distance 25-150 mm
- b Joint width 8 mm

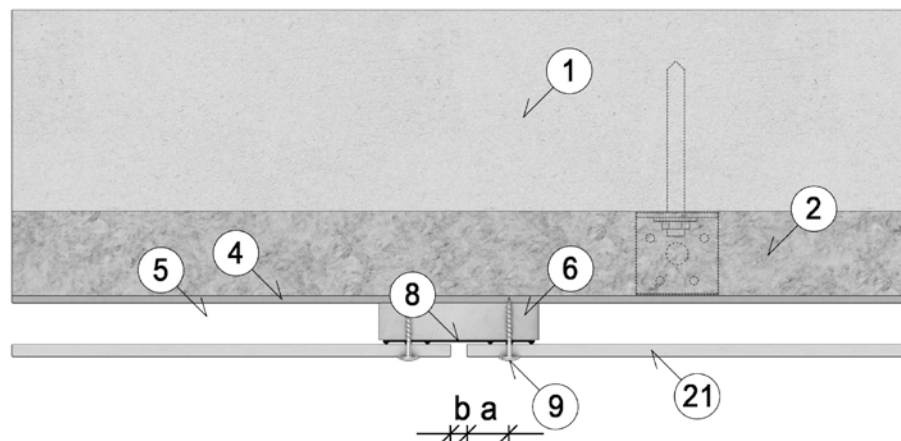

### Horizontal cross section intermediate support

- 1 Load bearing wall
- 2 Insulation
- 4 Wind break
- 5 Air gap min 25 mm
- 6 Batten min 25 x 62 mm
- 7 EPDM underlay 30 mm
- 9 Facade screw 4.5 x 36/41
- 21 Facade board

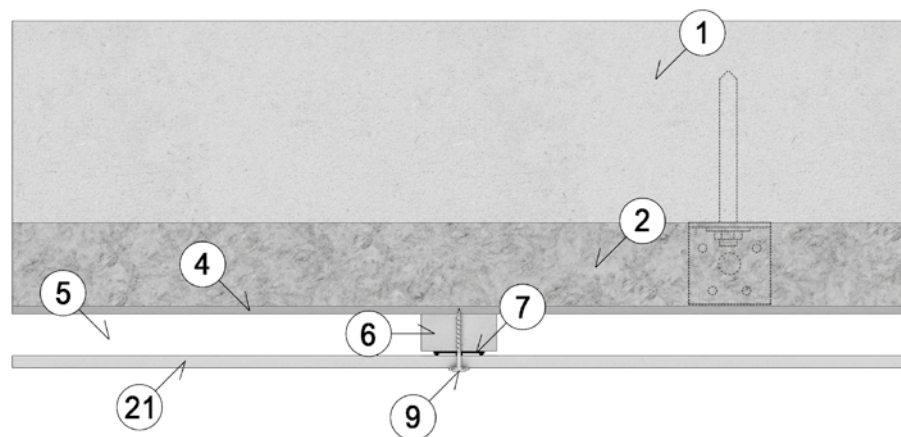

# Screws on wooden sub-constructions

## Horizontal cross section external corner

- 1 Load bearing wall
- 2 Insulation
- 4 Wind break
- 5 Air gap min 25 mm
- 6 Batten min 25 x 125 mm
- 8 EPDM underlay 90 mm
- 9 Facade screw 4.5 x 36/41
- 21 Facade board
- a Edge distance 25-150 mm
- b Joint width 8 mm

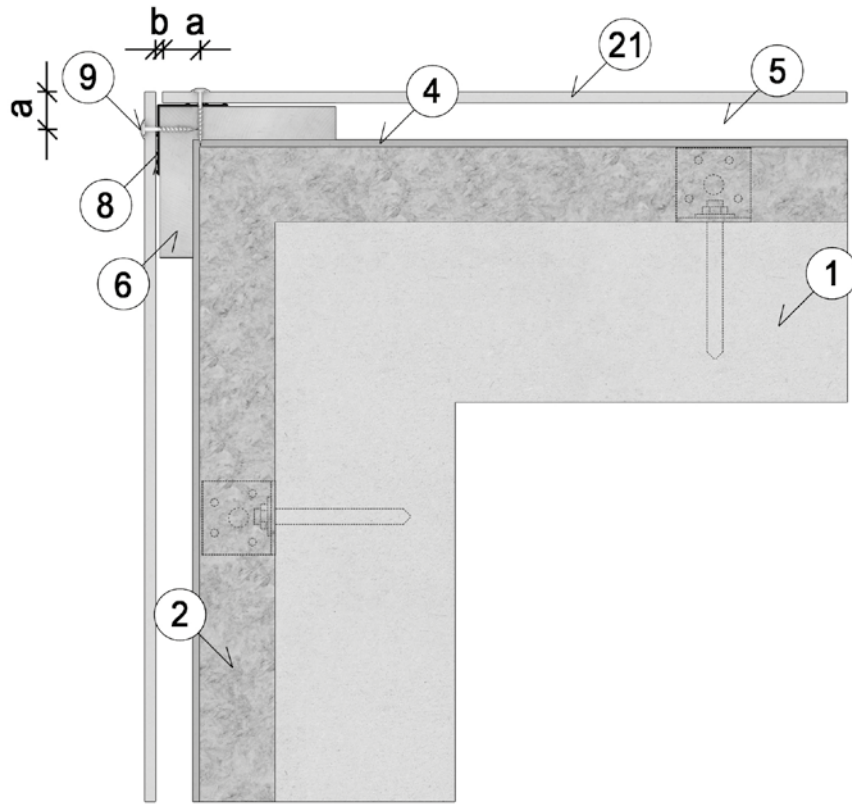

## Horizontal cross section internal corner

- 1 Load bearing wall
- 2 Insulation
- 4 Wind break
- 5 Air gap min 25 mm
- 6 Batten min 25 x 125 mm
- 8 EPDM underlay 90 mm
- 9 Facade screw 4.5 x 36/41
- 21 Facade board
- a Edge distance 25-150 mm
- b Joint width 8 mm

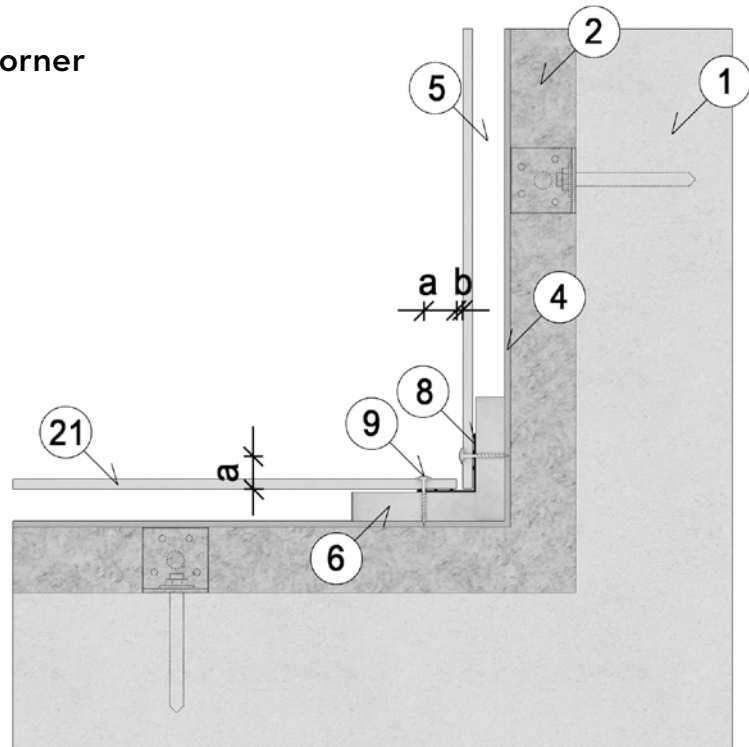



## Horizontal cross section window (Window recess max. 200 mm without ventilation)

- 1 Load bearing wall
- 2 Insulation
- 4 Wind break
- 5 Air gap min 25 mm
- 6 Batten min 25 x 125 mm
- 8 EPDM underlay 90 mm
- 9 Facade screw 4.5 x 36/41
- 21 Facade board
- 22 Window
- a Edge distance 25-150 mm
- b Joint width 8 mm

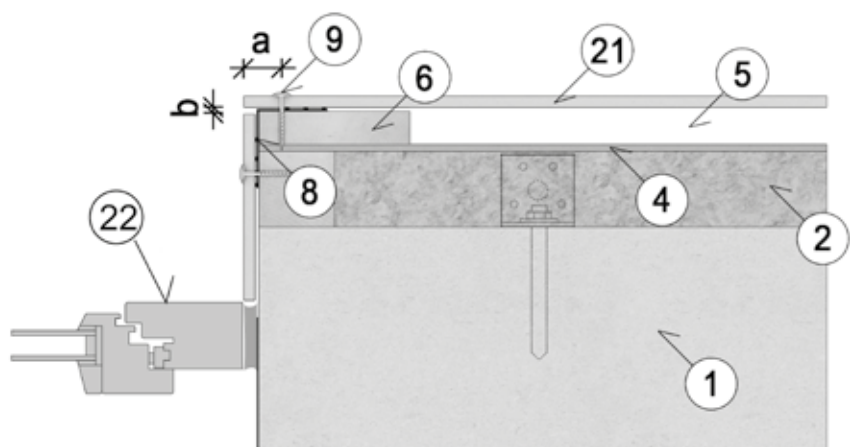

# Screws on wooden sub-constructions

## Vertical cross section horizontal joint

- 1 Load bearing wall
- 2 Insulation
- 4 Wind break
- 5 Air gap min 25 mm
- 8 EPDM underlay 90 mm
- 9 Facade screw 4.5 x 36/41
- 21 Facade board
- b Joint width 8 mm
- c Corner distance 100-150 mm

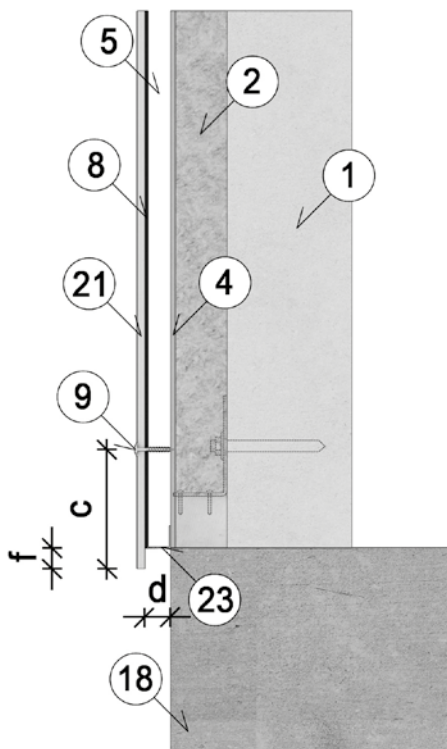
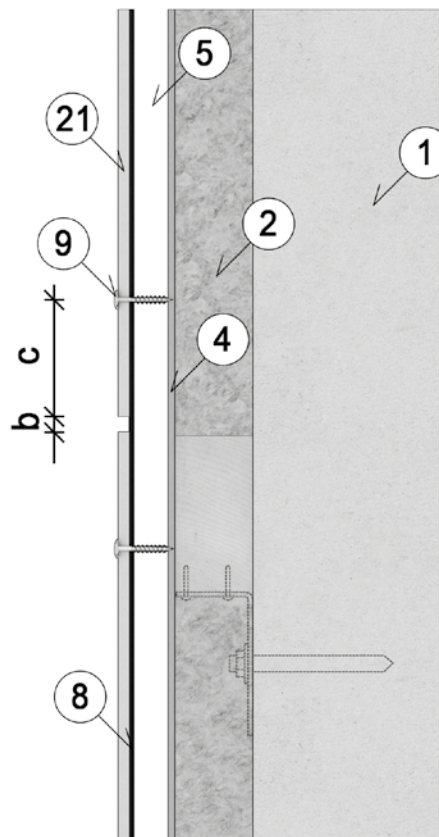

## Vertical cross section foundation

- 1 Load bearing wall
- 2 Insulation
- 4 Wind break
- 5 Air gap min 25 mm
- 8 EPDM underlay 90 mm
- 9 Facade screw 4.5 x 36/41
- 18 Foundation
- 21 Facade board
- 23 Insect grating
- c Corner distance 100-150 mm
- d Ventilation inlet min 200 cm²/m
- f Overhang approx. 30 mm

# Screws on wooden sub-constructions

## Vertical cross section roof edge

- 1 Load bearing wall
- 2 Insulation
- 4 Wind break
- 5 Air gap min 25 mm
- 8 EPDM underlay 90 mm
- 9 Facade screw 4.5 x 36/41
- 21 Facade board
- c Corner distance 100-150 mm
- d Ventilation outlet min 200 cm<sup>2</sup>/m
- f Overhang approx. 30 mm

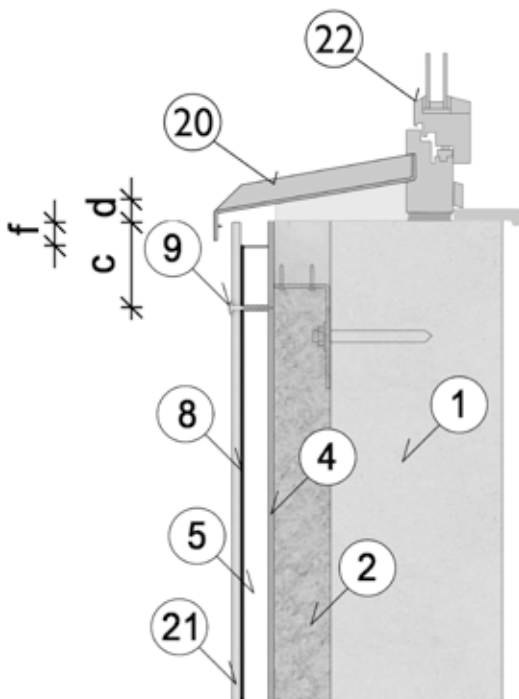
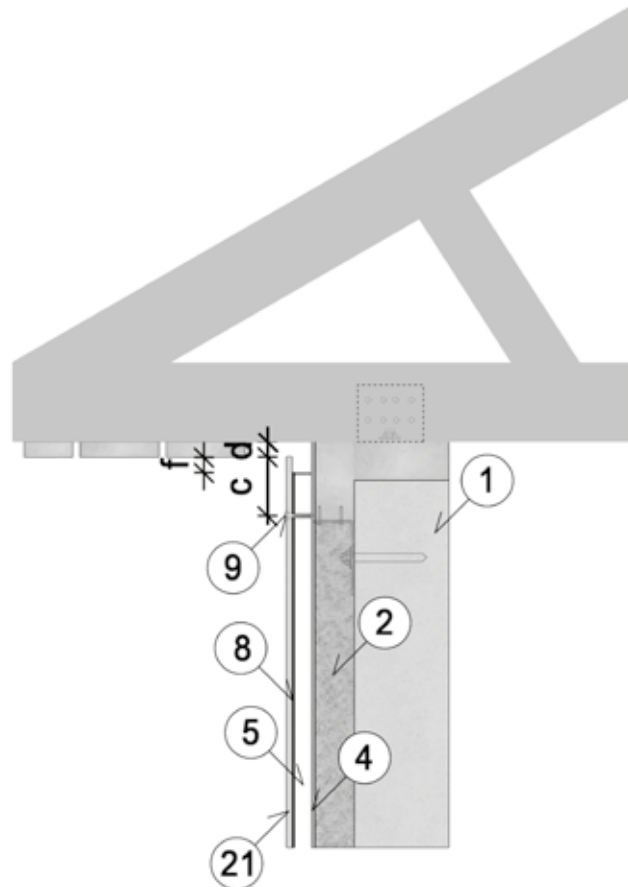

## Vertical cross section window sill

- 1 Load bearing wall
- 2 Insulation
- 4 Wind break
- 5 Air gap min 25 mm
- 8 EPDM underlay 90 mm
- 9 Facade screw 4.5 x 36/41
- 20 Window sill
- 21 Facade board
- 22 Window
- c Corner distance 100-150 mm
- d Ventilation outlet min 200 cm<sup>2</sup>/m
- f Overhang approx. 30 mm

# Screws on wooden sub-constructions

## Vertical cross section window upper edge (Window recess max 200 mm without ventilation)

- 1 Load bearing wall
- 2 Insulation
- 4 Wind break
- 5 Air gap min 25 mm
- 7 EPDM underlay 90 mm
- 9 Facade screw 4.5 x 36/41
- 21 Facade board
- 22 Window
- 23 Insect grating
- c Corner distance 100-150 mm
- d Ventilation inlet min 200 cm<sup>2</sup>/m
- f Overhang approx. 30 mm

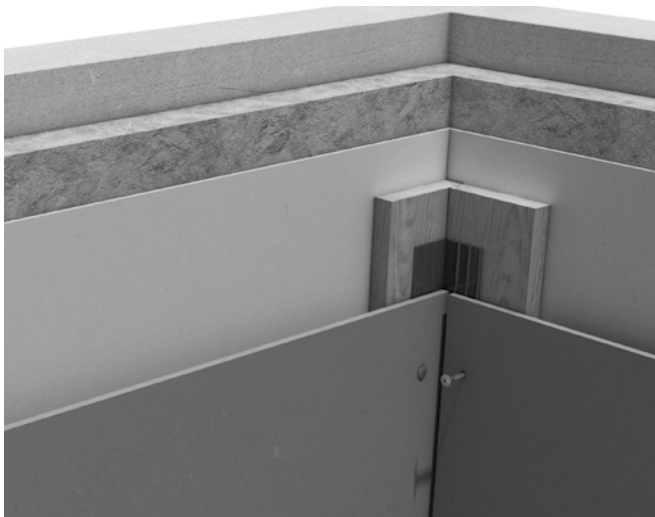
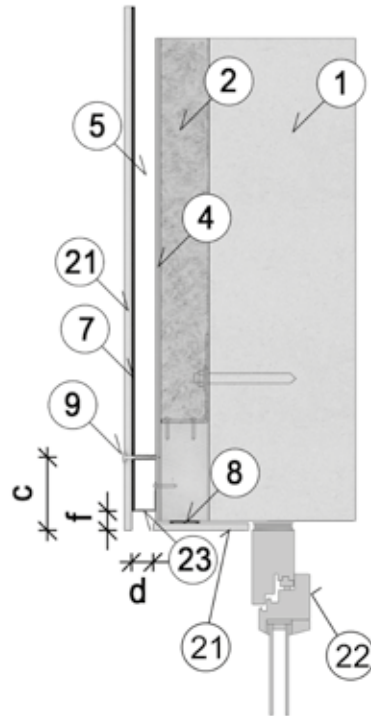

Internal corner

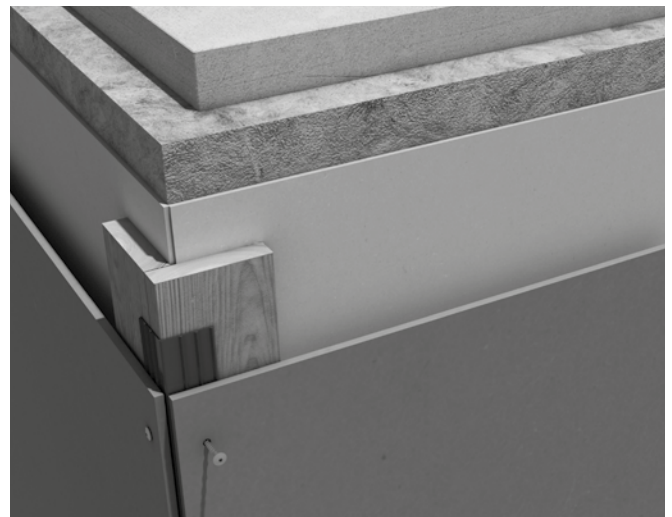

External corner

## Ceiling

Facade boards may also be installed as under-cladding or ceiling. The installation principles are the same as for vertical installation. Edge distance for screws 25 mm. Corner distance 100 mm. Max support and fixing distances 400 mm.

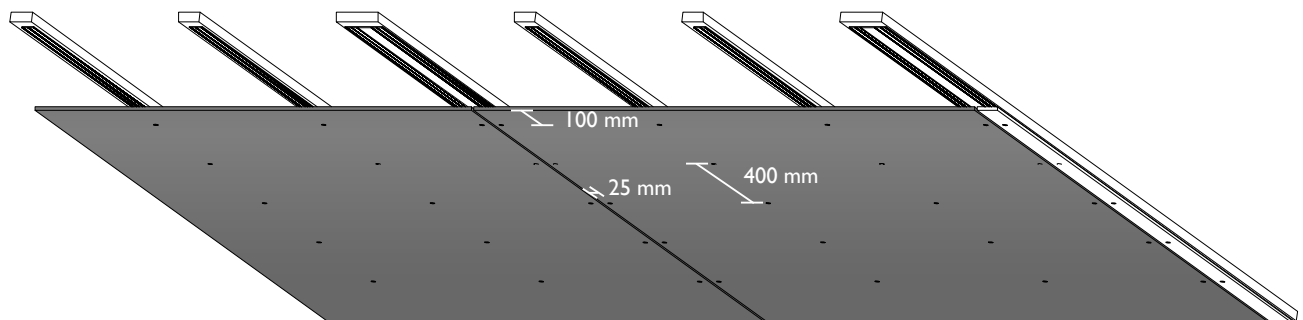

# Rivets on aluminium

Front view

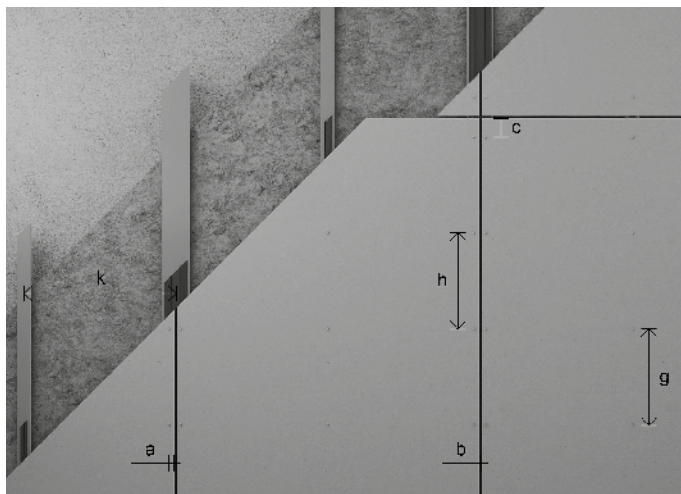

Ceiling

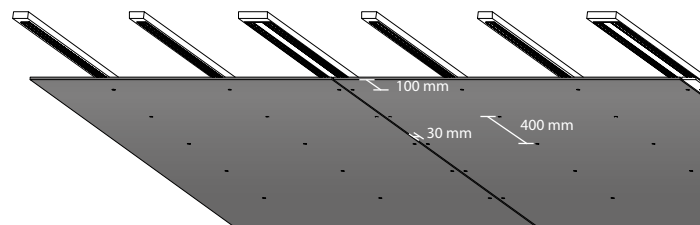

In order to achieve a correct and safe aluminium sub-construction, the supplier of the system should be consulted. However, there are a few rules to consider when it comes to the functionality of the facade boards:

- Length of the aluminium profiles is minimised to 3000 mm (one storey)
- The aluminium profiles must be fixed with one fix-point at the middle or the upper end and all other fixations as sliding points
- All joints of the aluminium profiles must be aligned so they can be followed by joints of the facade boards. A board must never cross an aluminium profile joint and be fixed to two separate aluminium profiles across a joint
- The facade boards must be fixed with a fix-point in the middle of the board. All other fixations are sliding points. In case of two intermediate supporting profiles, two fix-points at the same horizontal level are allowed
- Every 12 m of the facade a double framing must be installed in order to create a dilatation joint.
- **Important!** With installation with rivets, begin with the fix-points, followed by the sliding points above and finally the sliding points below.

## Fixing details

### Vertical board orientation

Installation with rivets on aluminium, vertical sub-construction

Max dimensions 8 x 1250 x 2500/3050 mm

Drill hole in the boards: Ø9

Max support distance	Max fixing distance	Edge distance	Corner distance
k mm	h, g mm	a mm	c mm
400-600**	400-600**	30-150	100-150*

\*Overhang e.g. windows or foundations max 200 mm

\*\*Depending on windload.

Contact Cembrit for further details.

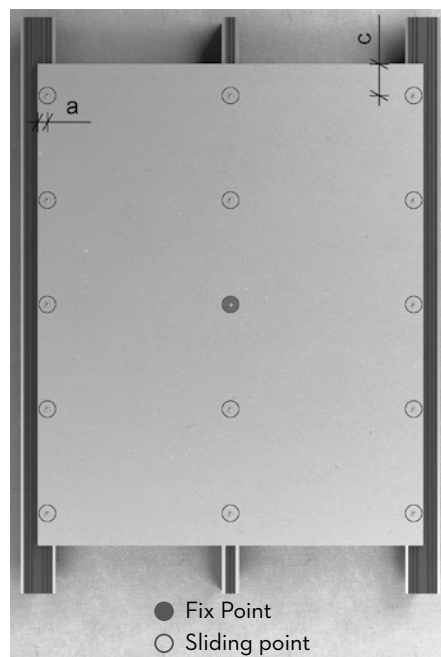

# Rivets on aluminium

## Horizontal orientation

Facade boards may be installed in a horizontal position on a vertical sub-structure. On metal framing, the edge distance  $a \geq 40$  mm and corner distance  $c \geq 100$  mm.

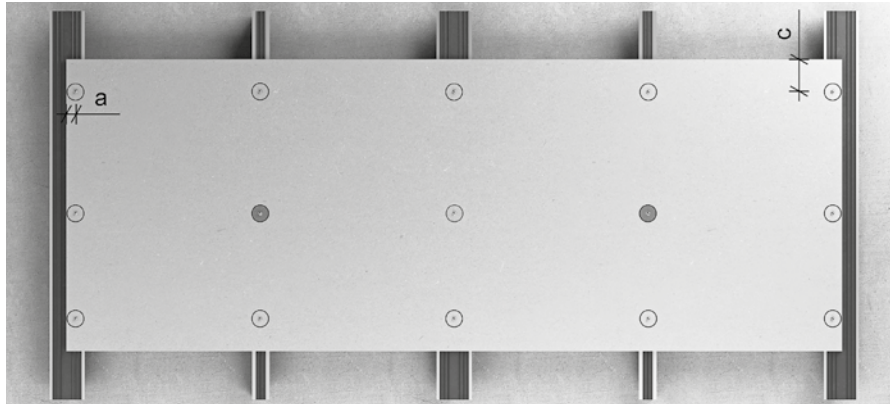

- Fix Point
- Sliding point

## Horizontal board orientation

Installation with rivets on aluminium, vertical sub-construction

Max dimensions 8 x 1250 x 2500/3050 mm

Drill hole in the boards:  $\varnothing 9$

Max support distance	Max fixing distance	Edge distance	Corner distance
k mm	h, g mm	a mm	c mm
400-600**	400-600**	40-150	100-150*

\*Overhang e.g. windows or foundations max 200 mm

\*\*Depending on windload.

Contact Cembrit for further details.



# Rivets on aluminium

## Horizontal cross section vertical joint

- 1 Load bearing wall
- 3 Insulation
- 5 Air gap min 25 mm
- 8 EPDM underlay 90 mm (optional)
- 11 Rivet 4.0x20 K14
- 16 Aluminium frame system
- 21 Facade board
- a Edge distance min 30/40 mm
- b Joint width 8 mm

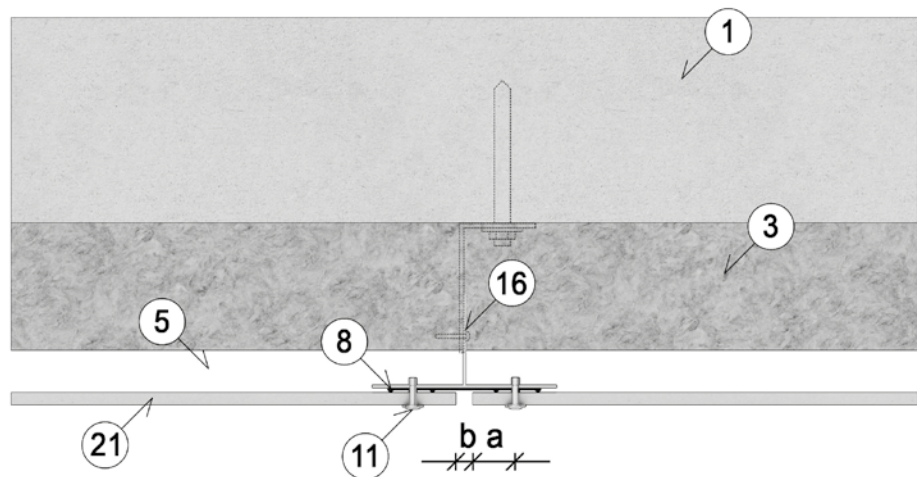

## Horizontal cross section intermediate support

- 1 Load bearing wall
- 3 Insulation
- 5 Air gap min 25 mm
- 7 EPDM underlay 30 mm (optional)
- 11 Rivet 4.0x20 K14
- 16 Aluminium frame system
- 21 Facade board

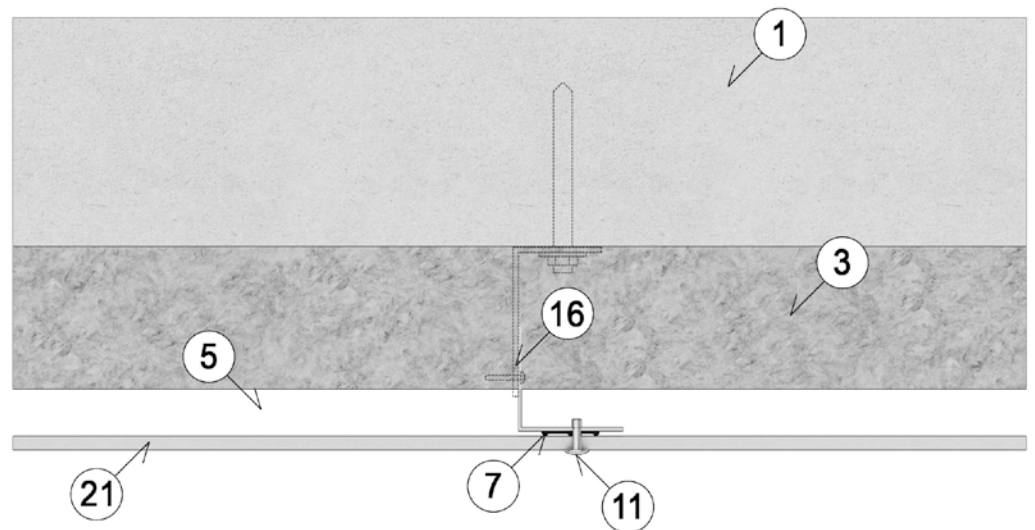

# Rivets on aluminium

## Horizontal cross section external corner

- 1 Load bearing wall
- 3 Insulation
- 5 Air gap min 25 mm
- 7 EPDM underlay 30 mm (optional)
- 8 EPDM underlay 90 mm (optional)
- 11 Rivet 4.0x20 K14
- 16 Aluminium frame system
- 17 Aluminium angle 60x60x2 mm
- 21 Facade board
- a Edge distance min 30/40 mm
- b Joint width 8 mm
- e Dist. to wall fixing max 200 mm

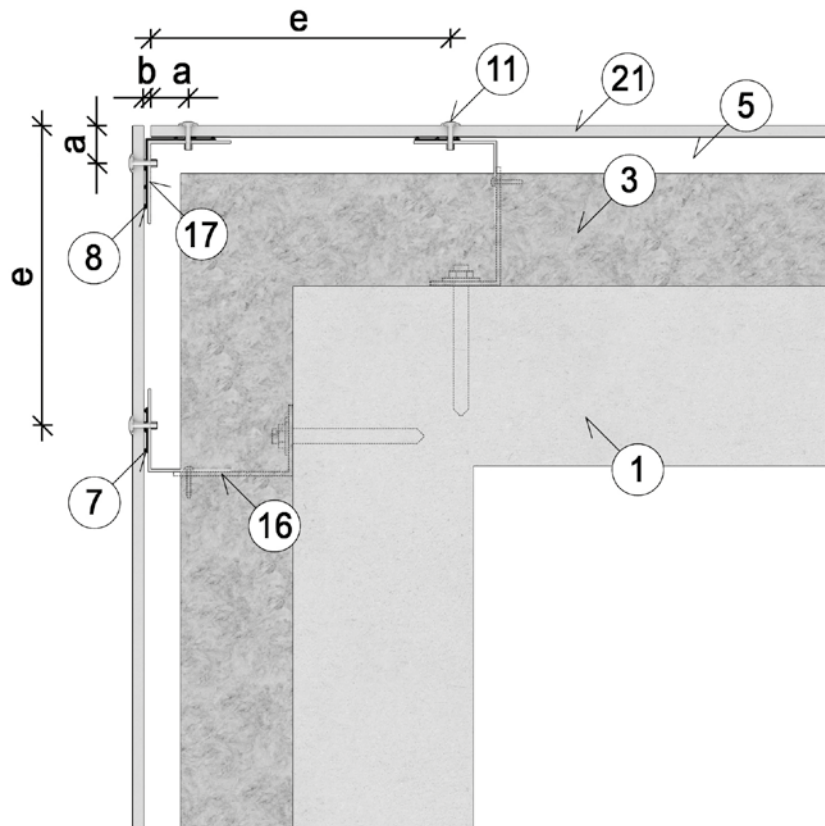

## Horizontal cross section internal corner

- 1 Load bearing wall
- 3 Insulation
- 5 Air gap min 25 mm
- 7 EPDM underlay 30 mm (optional)
- 8 EPDM underlay 90 mm (optional)
- 11 Rivet 4.0x20 K14
- 16 Aluminium frame system
- 17 Aluminium angle 60x60x2 mm
- 21 Facade board
- a Edge distance min 30/40 mm
- b Joint width 8 mm

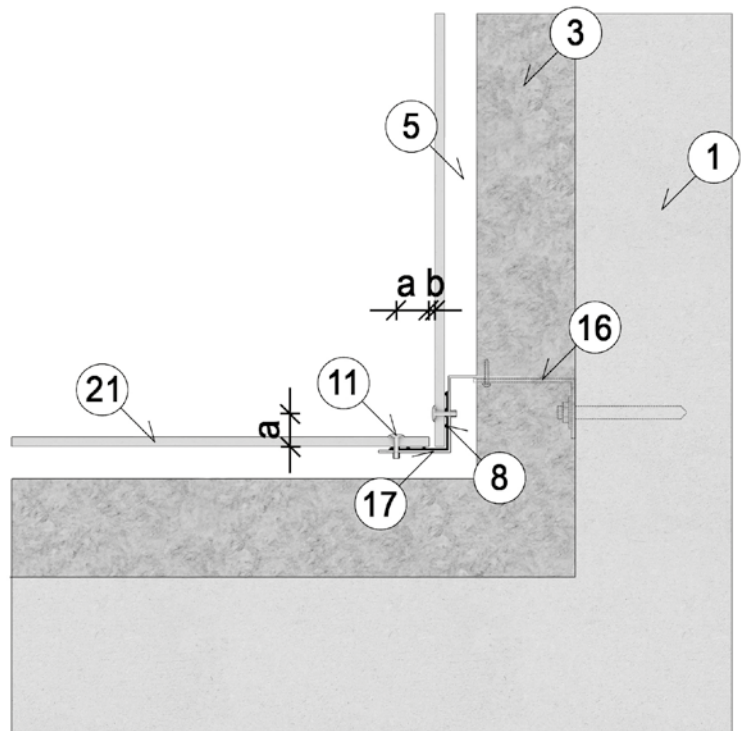

# Rivets on aluminium

## Horizontal cross section window

(Window recess max 200 mm without ventilation)

- 1 Load bearing wall
- 3 Insulation
- 5 Air gap min 25 mm
- 7 EPDM underlay 30 mm (optional)
- 8 EPDM underlay 90 mm (optional)
- 11 Rivet 4.0x20 K14
- 16 Aluminium frame system
- 17 Aluminium angle 60x60x2 mm
- 21 Facade board
- 22 Window
- a Edge distance min 30/40 mm
- b Joint width 8 mm

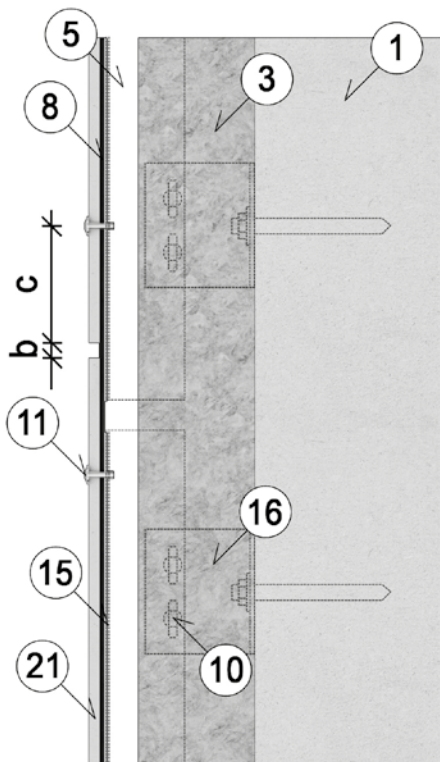
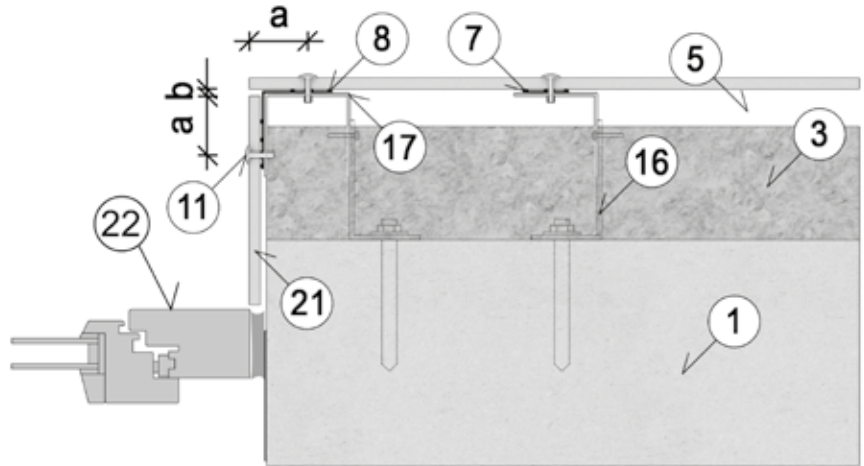

## Vertical cross section horizontal joint

- 1 Load bearing wall
- 3 Insulation
- 5 Air gap min 25 mm
- 8 EPDM underlay 90 mm (optional)
- 10 Fixing point profile/bracket
- 11 Rivet 4.0x20 K14
- 15 Aluminium profile
- 16 Aluminium frame system
- 21 Facade board
- b Joint width 8 mm
- c Corner distance min 100 mm

Note! Boards must never be fixed to two separate profiles!

# Rivets on aluminium

## Vertical cross section foundation

- 1 Load bearing wall
- 3 Insulation
- 5 Air gap min 25 mm
- 8 EPDM underlay 90 mm (optional)
- 10 Fixing point profile/bracket
- 11 Rivet 4.0x20 K14
- 15 Aluminium profile
- 16 Aluminium frame system
- 18 Foundation
- 21 Facade board
- 23 Insect grating
- c Corner distance 100-150 mm
- d Ventilation inlet min 200cm<sup>2</sup>/m
- f Overhang approx. 30 mm

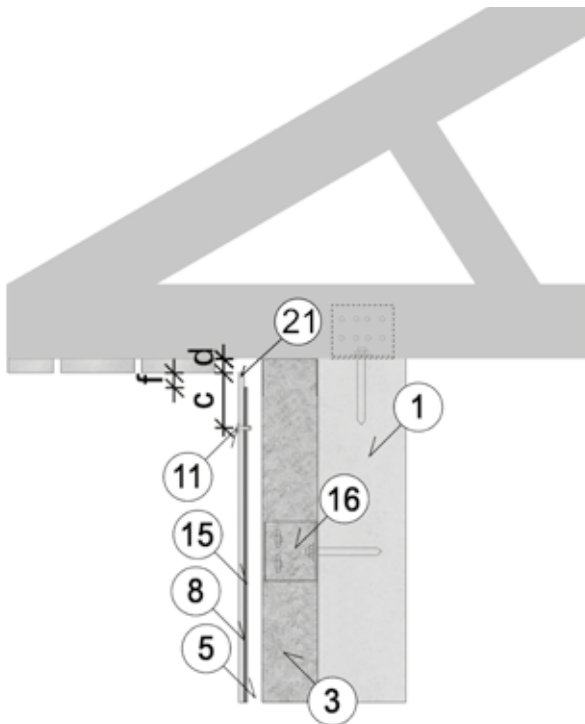
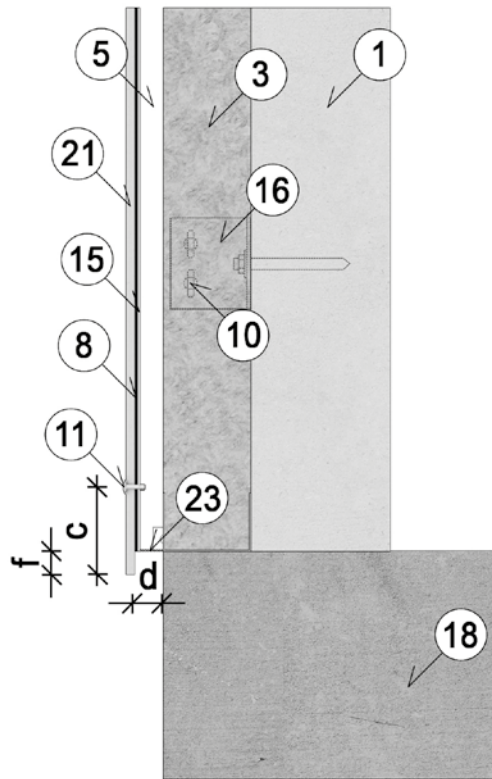

## Vertical cross section roof edge

- 1 Load bearing wall
- 3 Insulation
- 5 Air gap min 25 mm
- 8 EPDM underlay 90 mm (optional)
- 11 Rivet 4.0x20 K14
- 15 Aluminium profile
- 16 Aluminium frame system
- 21 Facade board
- c Corner distance 100-150 mm
- d Ventilation outlet min 200cm<sup>2</sup>/m
- f Overhang approx. 30 mm

# Rivets on aluminium

## Vertical cross section window sill

- 1 Load bearing wall
- 3 Insulation
- 5 Air gap min 25 mm
- 8 EPDM underlay 90 mm (optional)
- 11 Rivet 4.0x20 K14
- 15 Aluminium profile
- 16 Aluminium frame system
- 20 Window sill
- 21 Facade board
- 22 Window
- c Corner distance 100-150 mm
- d Ventilation outlet min 200cm<sup>2</sup>/m
- f Overhang approx. 30 mm

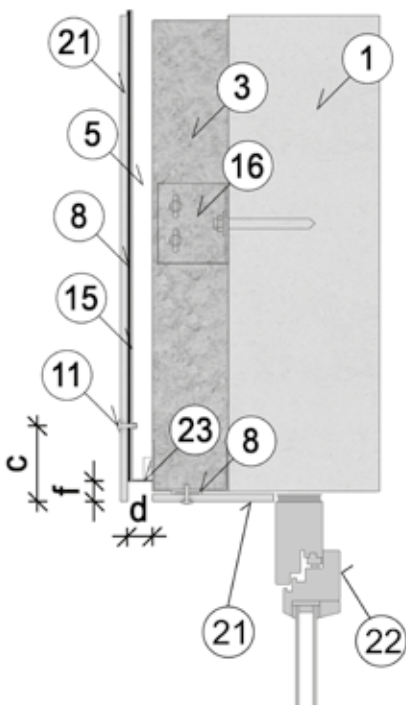
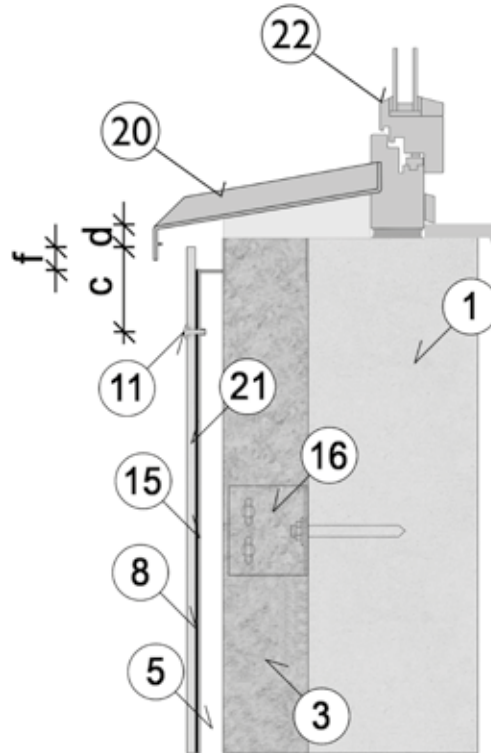

## Vertical cross section window upper edge (Window recess max 200 mm without ventilation)

- 1 Load bearing wall
- 3 Insulation
- 5 Air gap min 25 mm
- 8 EPDM underlay 90 mm (optional)
- 11 Rivet 4.0x20 K14
- 15 Aluminium profile
- 16 Aluminium frame system
- 21 Facade board
- 22 Window
- 23 Insect grating
- c Corner distance 100-150 mm
- d Ventilation inlet min 200cm<sup>2</sup>/m
- f Overhang approx. 30 mm

# Screws and rivets on steel sub-construction

In order to achieve a correct and safe steel sub-construction, the supplier of the system should be consulted. However, there are a few rules to consider when it comes to the functionality of the facade boards:

- Length of the steel profiles is maximum 3000 mm (one storey)
  - The steel profiles must be fixed with one fix-point at the middle or the upper end and all other fixations as sliding points
  - All joints of the steel profiles must be aligned allowing them to be followed by joints of the facade boards. A board must never cross a joint in the steel profiles. A board must never cross a steel profile joint and be fixed to two separate steel profiles across a joint
  - The facade boards must be fixed with a fix-point in the middle of the board. All other fixations are sliding points. In case of two intermediate supporting profiles, two fix-points at the same horizontal level are allowed
  - Every 12 m of the facade a double framing must be installed in order to create a dilatation joint.
  - **Important!** Fasten the boards at the fix-point(s), followed by the sliding points above and finally the sliding points below.
- (The following illustrations show installation with screws - details are similar for rivets)

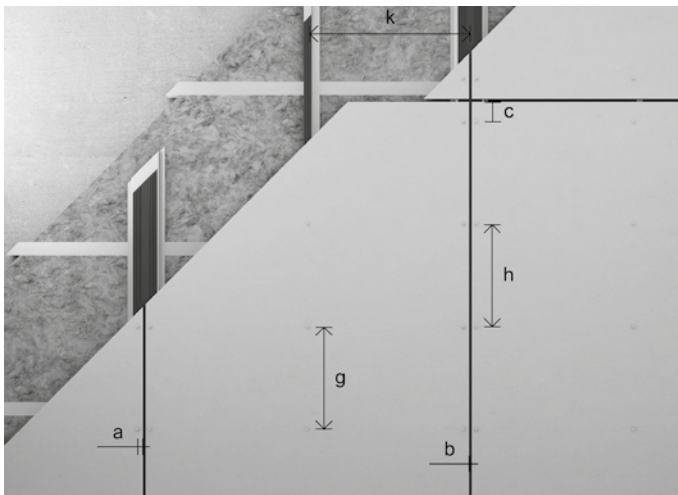

## Ceiling

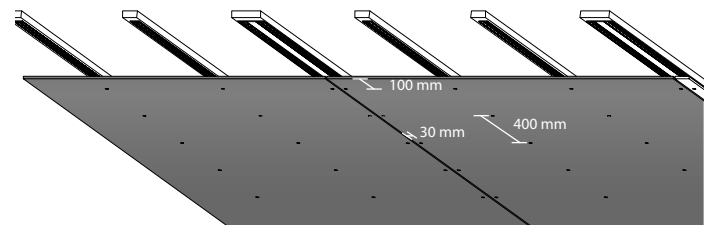

## Fixing details

### Vertical board orientation

Installation on steel, vertical sub-construction

Max dimensions 8 x 1250 x 2500/3050 mm

Drill hole in the boards: Ø8

Max support distance	Max fixing distance	Edge distance	Corner distance
k mm	h, g mm	a mm	c mm
400-600**	400-600**	30-150	100-150*

\*Overhang e.g. windows or foundations max 200 mm

\*\*Depending on windload.

Contact Cembrit for further details.

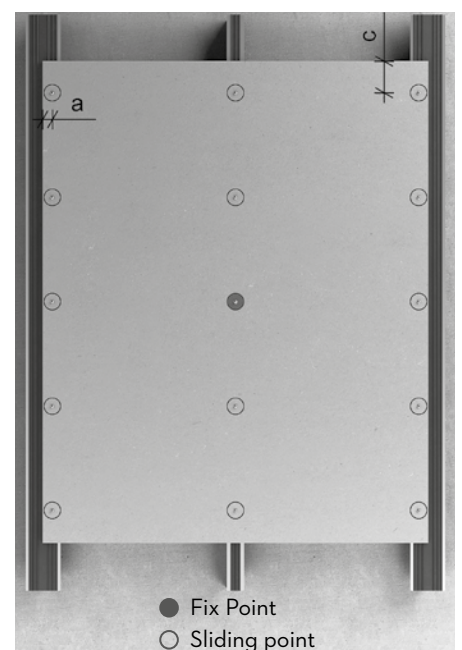

# Screws and rivets on steel sub-construction

## Horizontal orientation

Facade boards may be installed in a horizontal position on a vertical sub-structure. On metal framing, the edge distance must be  $a \geq 40$  mm and corner distance  $c \geq 100$  mm.

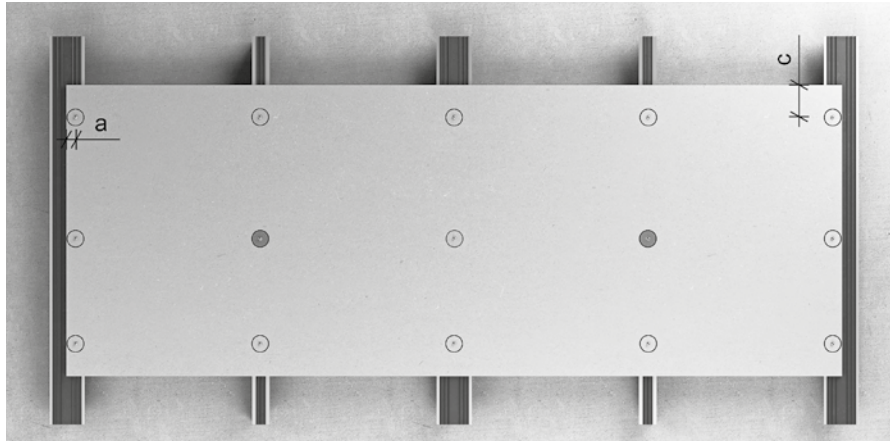

- Fix Point
- Sliding point

## Horizontal board orientation

Installation on steel, vertical sub-construction

Max dimensions 8 x 1250 x 2500/3050 mm

Drill hole in the boards:  $\varnothing 8$

Max support distance	Max fixing distance	Edge distance	Corner distance
k mm	h, g mm	a mm	c mm
400-600**	400-600**	40-150	100-150*

\*Overhang e.g. windows or foundations max 200 mm

\*\*Depending on windload.

Contact Cembrit for further details.

# Screws and rivets on steel sub-construction

## Horizontal cross section vertical joint

- 1 Load bearing wall
- 3 Insulation
- 5 Air gap min 25 mm
- 8 EPDM underlay 90 mm (optional)
- 9 Facade screw 4.8x25
- 21 Facade board
- 24 Steel profile
- a Edge distance min 30/40 mm
- b Joint width 8 mm

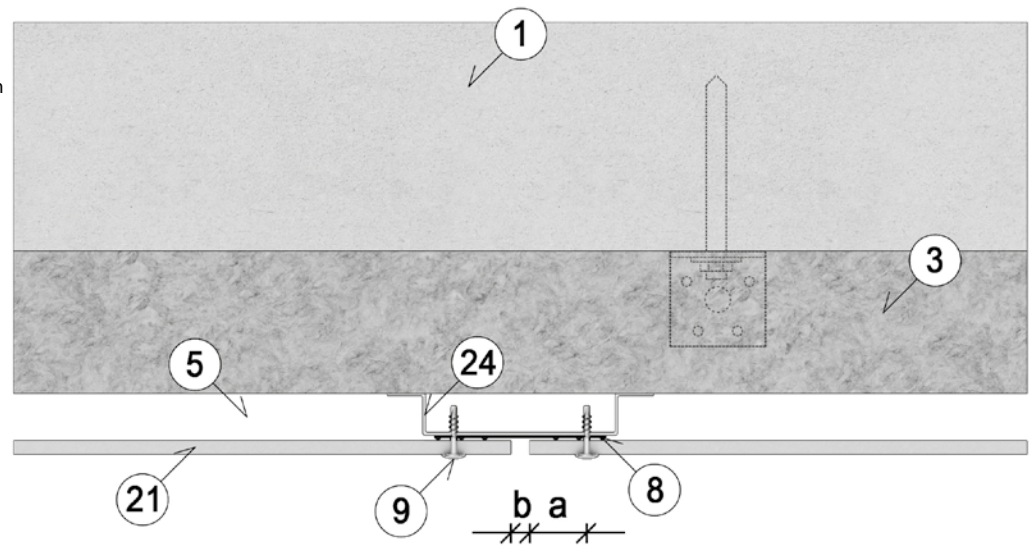

## Horizontal cross section intermediate support

- 1 Load bearing wall
- 3 Insulation
- 5 Air gap min 25 mm
- 8 EPDM underlay 30 mm (optional)
- 9 Facade screw 4.8x25
- 21 Facade board
- 24 Steel profile

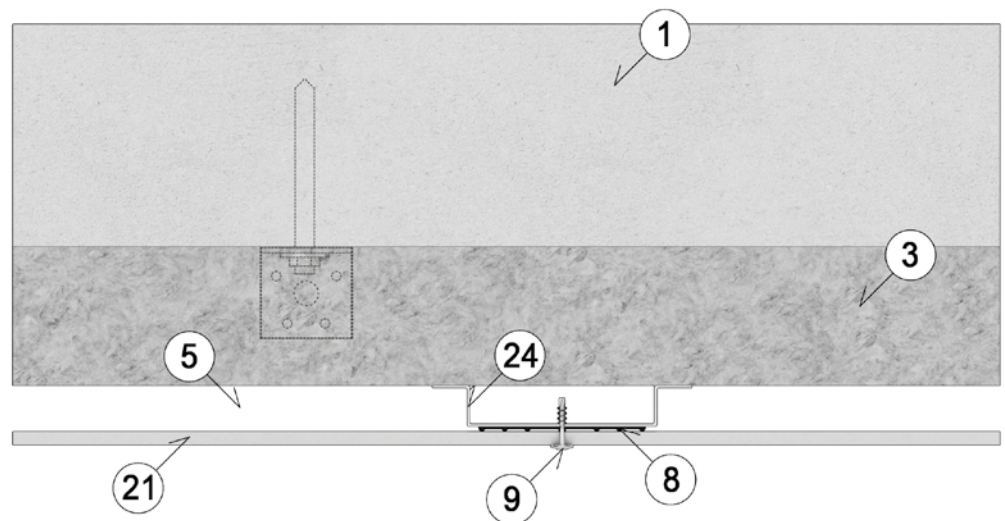



# Screws and rivets on steel sub-construction

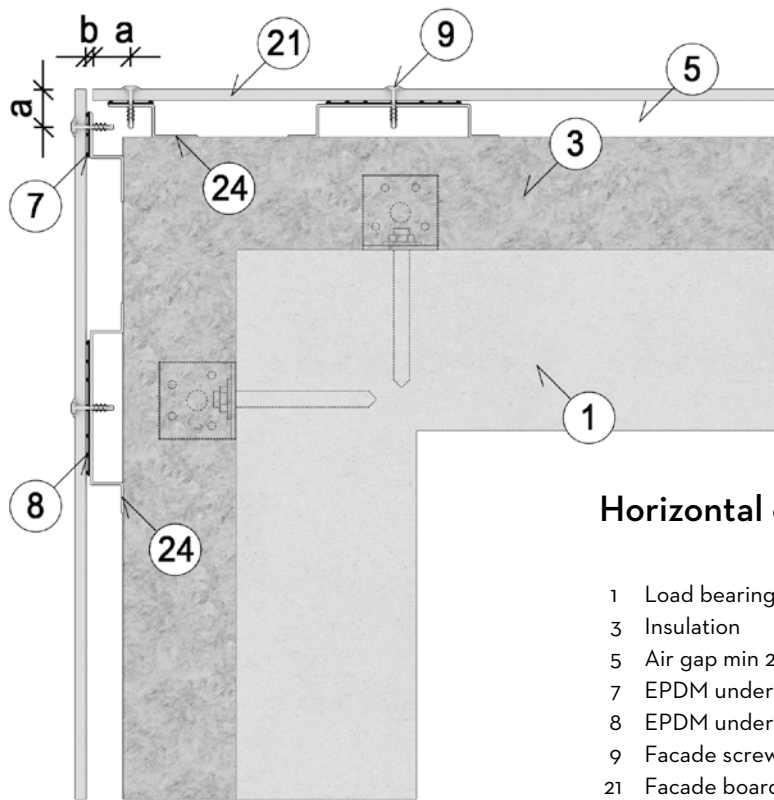

**Horizontal cross section external corner**

- 1 Load bearing wall
- 3 Insulation
- 5 Air gap min 25 mm
- 7 EPDM underlay 30 mm (optional)
- 8 EPDM underlay 90 mm (optional)
- 9 Facade screw 4.8x25
- 21 Facade board
- 24 Steel profile
- a Edge distance min 30/40 mm
- b Joint width 8 mm

**Horizontal cross section internal corner**

- 1 Load bearing wall
- 3 Insulation
- 5 Air gap min 25 mm
- 7 EPDM underlay 30 mm (optional)
- 8 EPDM underlay 90 mm (optional)
- 9 Facade screw 4.8x25
- 21 Facade board
- 24 Steel profile
- a Edge distance min 30/40 mm
- b Joint width 8 mm

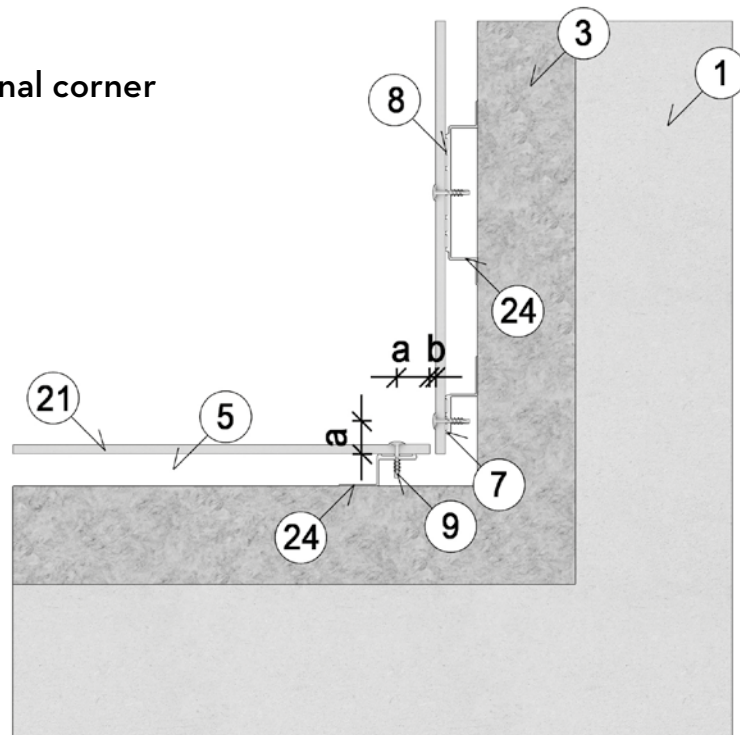

# Screws and rivets on steel sub-construction

## Horizontal cross section window

(Window recess max 200 mm without ventilation)

- 1 Load bearing wall
- 3 Insulation
- 5 Air gap min 25 mm
- 8 EPDM underlay 90 mm (optional)
- 9 Facade screw 4.8x25
- 21 Facade board
- 22 Window
- 24 Steel profile
- a Edge distance min 30/40 mm
- b Joint width 8 mm

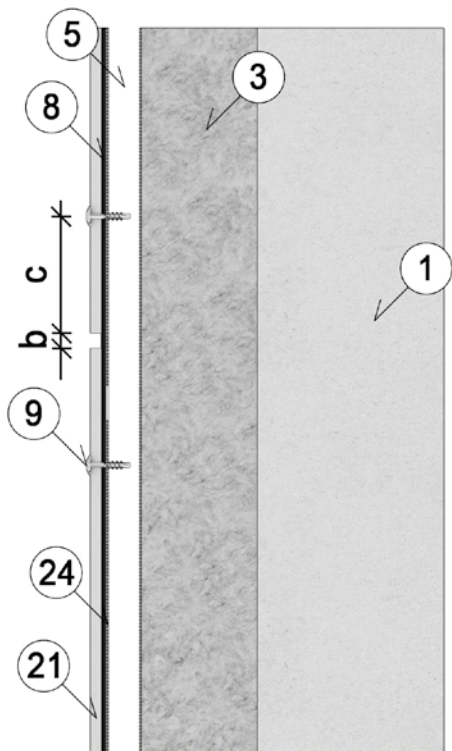
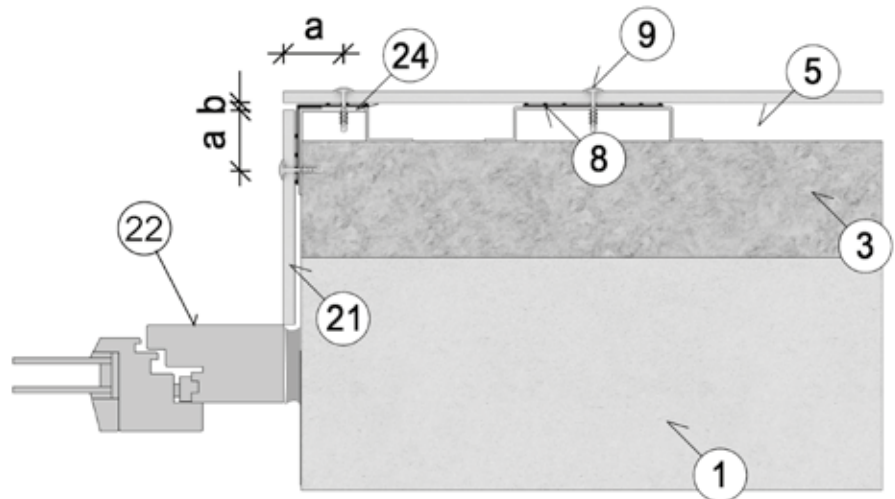

## Vertical cross section horizontal joint

- 1 Load bearing wall
- 3 Insulation
- 5 Air gap min 25 mm
- 8 EPDM underlay 90 mm (optional)
- 9 Facade screw 4.8x25
- 21 Facade board
- 24 Steel profile
- b Joint width 8 mm
- c Corner distance min 100 mm

# Screws and rivets on steel sub-construction

## Vertical cross section foundation

- 1 Load bearing wall
- 3 Insulation
- 5 Air gap min 25 mm
- 8 EPDM underlay 90 mm (optional)
- 9 Facade screw 4.8x25
- 18 Foundation
- 21 Facade board
- 23 Insect grating
- 24 Steel profile
- c Corner distance 100-150 mm
- d Ventilation inlet min 200 cm<sup>2</sup>/m
- f Overhang approx. 30 mm

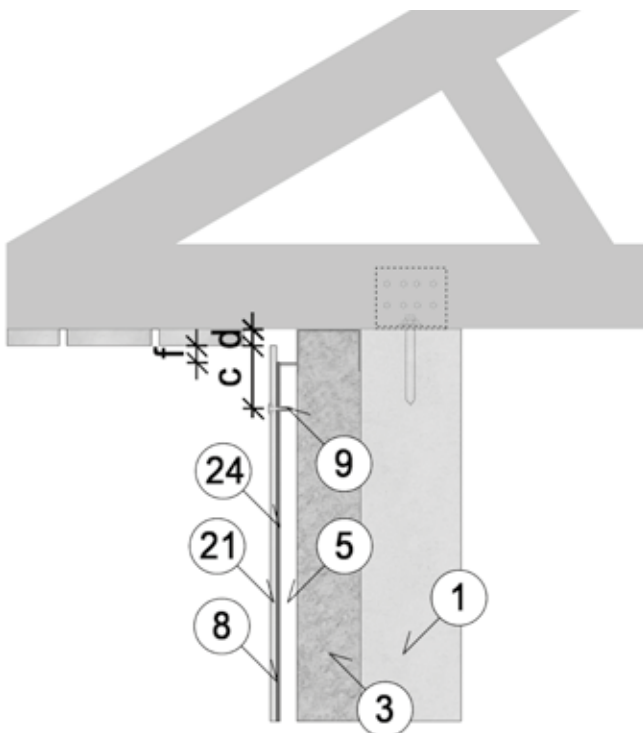
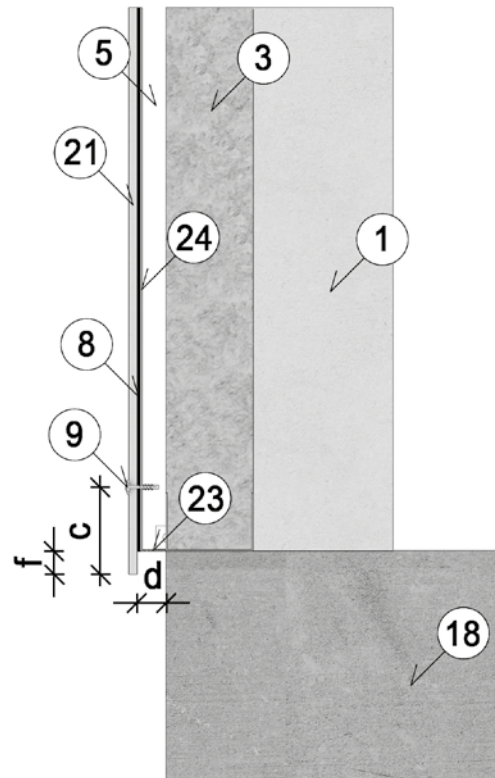

## Vertical cross section roof edge

- 1 Load bearing wall
- 3 Insulation
- 5 Air gap min 25 mm
- 8 EPDM underlay 90 mm (optional)
- 9 Facade screw 4.8x25
- 19 Eave
- 21 Facade board
- 24 Steel profile
- c Corner distance 100-150 mm
- d Ventilation outlet min 200 cm<sup>2</sup>/m
- f Overhang approx. 30 mm

# Screws and rivets on steel sub-construction

## Vertical cross section window sill

- 1 Load bearing wall
- 3 Insulation
- 5 Air gap min 25 mm
- 8 EPDM underlay 90 mm (optional)
- 9 Facade screw 4.8x25
- 20 Window sill
- 21 Facade board
- 22 Window
- 24 Steel profile
- c Corner distance 100-150 mm
- d Ventilation outlet min 200 cm<sup>2</sup>/m
- f Overhang approx. 30 mm

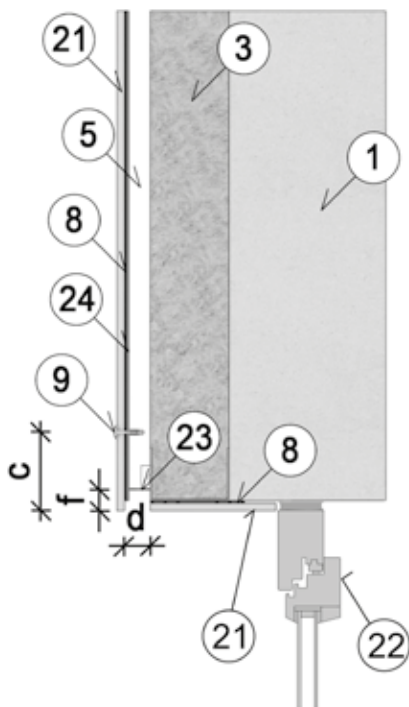
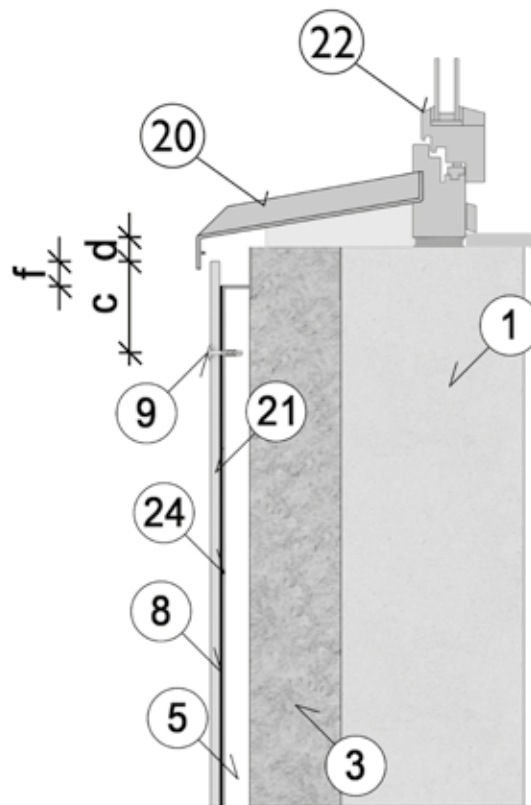

## Vertical cross section window upper edge (Window recess max 200 mm without ventilation)

- 1 Load bearing wall
- 3 Insulation
- 5 Air gap min 25 mm
- 8 EPDM underlay 90 mm (optional)
- 9 Facade screw 4.8x25
- 21 Facade board
- 22 Window
- 23 Insect grating
- 24 Steel profile
- c Corner distance 100-150 mm
- d Ventilation inlet min 200 cm<sup>2</sup>/m
- f Overhang approx. 30 mm

# Weatherboards

Weatherboards are very much used on dormers, eaves, gables, carports, etc. They can be fixed on vertical as well as horizontal sub-constructions. Visible fixing and invisible, concealed fixing are possible. Weatherboards can be cut to size on site, or they can be ordered cut to size from Cembrit.

**Note!** The table below covers weatherboards up to a width of 300 mm with a single side fixing. Wider boards should be fixed with double sided fixing in accordance with the fixing details in the table page 9.

With this installation method, the board length is limited to max 2500 mm.

## Fixing details for vertical sub-construction

Board Thickness mm	Max support distance	Min edge distances		Drill holes in board	
		a mm	m mm	Screws on wood and steel	Rivets on aluminium and steel
8	400	25 on wood 30 on aluminium and steel	40	Ø8 on wood Ø8 on steel	Ø9

### Front view

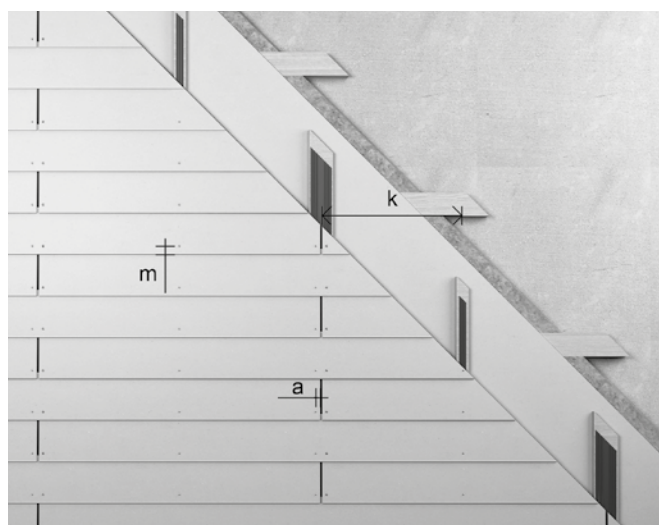

Vertical sub-construction - visible fixing

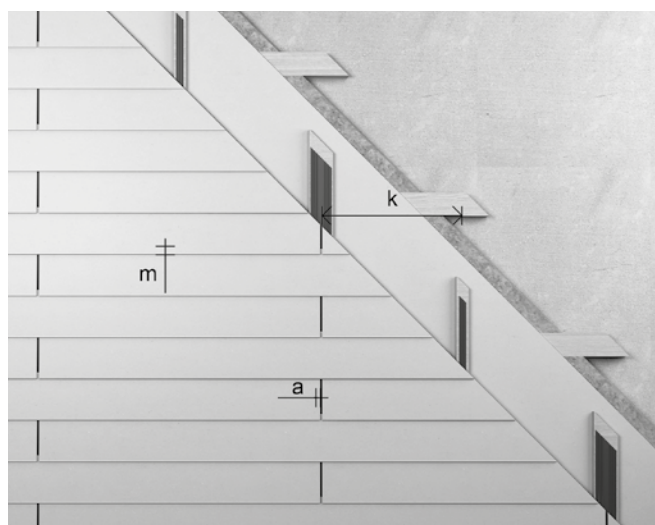

Vertical sub-construction - invisible, concealed fixing

# Weatherboards

## Horizontal cross section vertical joint

- 1 Load bearing wall
- 2 Insulation
- 4 Wind break
- 5 Air gap min 25 mm
- 6 Batten min 25 x 125 mm planed
- 8 EPDM underlay 90 mm
- 9 Facade screw
- 21 Facade board
- a Edge distance min 25 mm
- b Joint width 8 mm

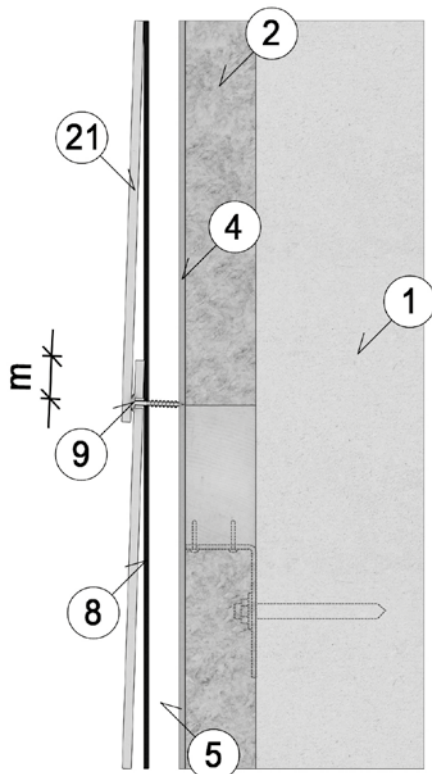
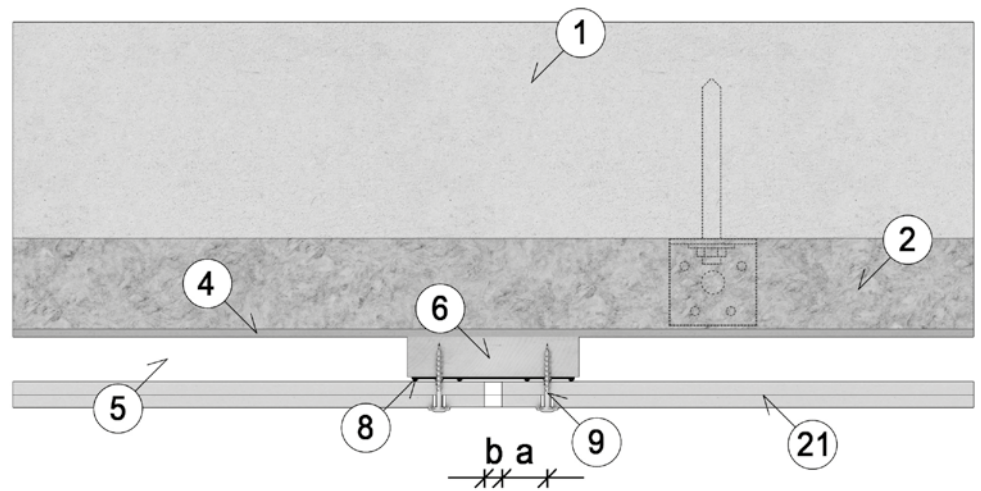

## Vertical cross section invisible, concealed fixing

- 1 Load bearing wall
- 2 Insulation
- 4 Windbreak
- 5 Air gap min 25 mm
- 8 EPDM underlay 90 mm
- 9 Facade screw
- 21 Facade board
- m Edge distance min 40 mm

# Weatherboards

## Vertical cross section visible fixing

- 1 Load bearing wall
- 2 Insulation
- 4 Windbreak
- 5 Air gap min 25 mm
- 8 EPDM underlay 90 mm
- 9 Facade screw
- 21 Facade board
- m Edge distance min 40 mm

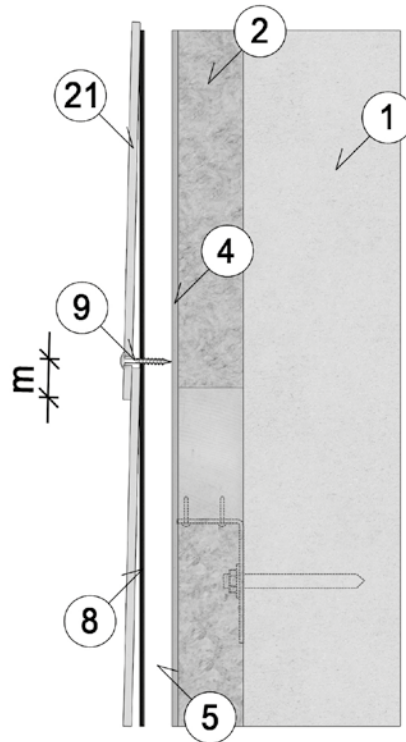

## 1 on 2 (double cladding)

## Fixing details on wood

Thickness mm	Max support distance	Max fixing distance ≤8 floors	Max fixing distance >8 floors	Min edge distances			Drill holes in board		
				a mm	m mm	c mm	Screws on wood	Rivets on aluminium	Screws on steel
8	k mm	b mm	b mm	25	40	100	Ø8	Ø9	Ø8

## Front view



1 on 2 (double cladding)

# Weatherboards

## Horizontal cross section 1 on 2

- 1 Load bearing wall
- 2 Insulation
- 4 Wind break
- 5 Air gap min 25 mm
- 6 Batten min 25 x 62 mm planed
- 7 EPDM underlay 30 mm
- 9 Facade screw
- 21 Facade board
- a Edge distance min 25 mm
- m Edge distance min 40 mm

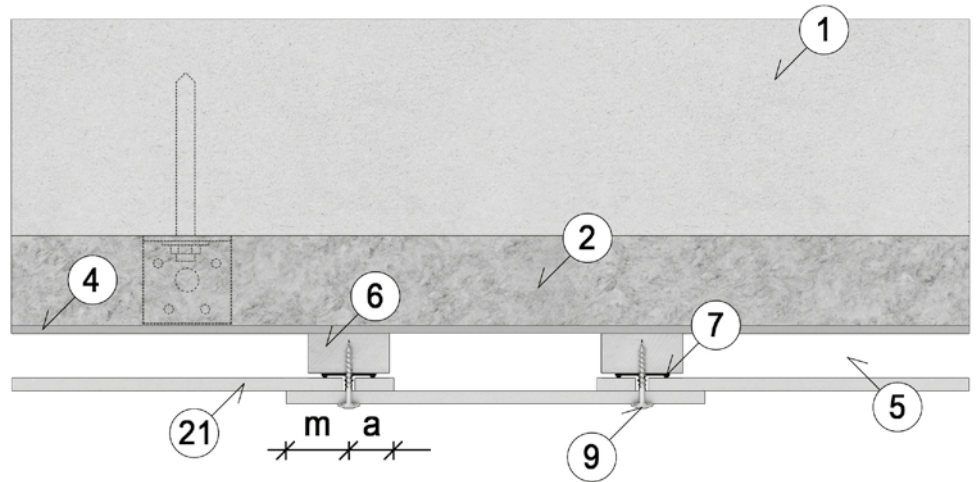

## Vertical cross section 1 on 2

- 1 Load bearing wall
- 2 Insulation
- 4 Windbreak
- 5 Air gap min 25 mm
- 7 EPDM underlay 30 mm
- 9 Facade screw
- 21 Facade board
- b Joint width 8 mm
- c Corner distance min 100 mm

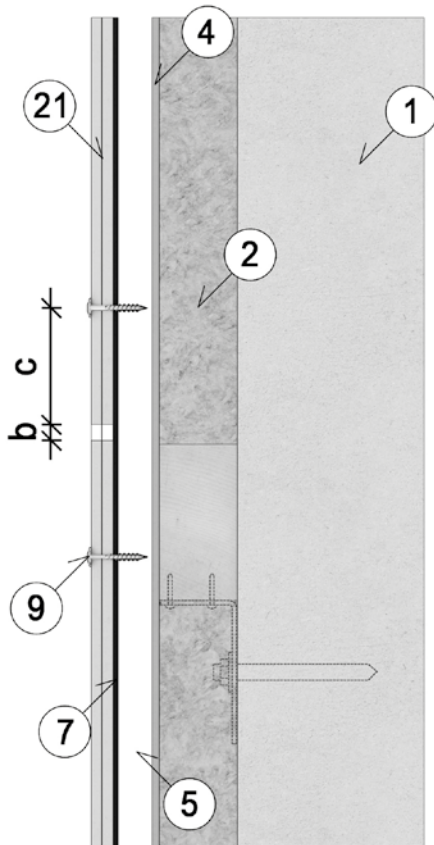



# Storing, Handling and Processing

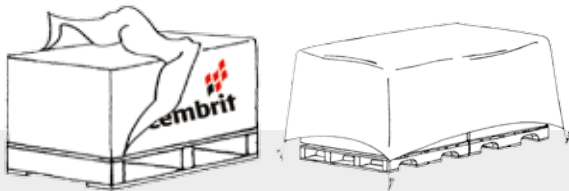

## Storing and handling

Cembrit products are delivered with plastic protection cover. If undamaged the plastic cover provides good protection against weather conditions during transportation.

### Transport and warehousing

Cembrit boards should preferably be stored dry under roof and always on a flat and dry level surface on pallets or sleepers with max 500 mm distance. Max 5 pallets in a stack.

**Note!** If stored more than 2-3 weeks the pallets should be kept inside under dry and ventilated conditions.

### At the building site

The plastic cover is for dust protection only. If upon arrival at the building site the pallets stored outside the plastic cover should be removed and replaced with a tarpaulin leaving the possibility of ventilation around the boards.

**Note!** If stored more than 2-3 weeks the pallets should be kept inside under dry and ventilated conditions.

### Lifting products off the pallet

The boards must be lifted off the pallet and not drawn over the next board. This will cause scratches and damages on the surface. **Keep the pallets covered with a tarpaulin during storage.**

## Processing

### Safety

As for all other building materials, safety precautions must be taken into account and local laws and regulations must be observed.

Cutting and drilling are subject to dust development, and proper precautions must be taken by using appropriate dust extraction equipment. Dust from fibre-cement boards is characterised as mineral dust and a prolonged exposure to this may cause lung disease.

### Protective foam

Cembrit painted boards are equipped with polyethylene foam between the boards for protection of the surface during transportation and processing. Polyethylene is an environmentally friendly polymer which can be disposed of by deposition or incineration.

### Cutting

Cutting to size may be done with normal slow or fast running hand tools or stationary equipment. When using fast running tools, dust

exhaustion must be employed. All Cembrit boards may be cut with a circular saw or a jigsaw equipped with a diamond tipped blade. Sharp edges are made with fast running diamond tipped tools. Cut edges should be bevelled with sand paper.

**Note!** When using hand tools, cut the boards backside up. When using stationary saw equipment, cut the boards front-side up (the saw blade must always attack the board from the front-side). The periphery speed of the circular saw should be 40-50 m/s. Cutting depth 10-15 mm beyond the board.

### Fast running electrical equipment

Hand held circular saws leave a fine and sharp edge on the boards and provide fine dust.

Due to the speed of the blade the dust is dispersed over a larger area. Therefore, it is necessary to establish sufficient exhaustion and if needed the operator should carry personal safety equipment.

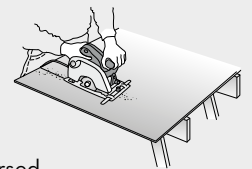

### Operation parameters for Cembrit saw blades

Saw blade Ø mm	Ø160	Ø190	Ø216	Ø250	Ø300
Thickness mm	2.4 mm	2.4 mm	2.6 mm	2.6 mm	2.8 mm
Hole size mm	20 mm	30 mm	30 mm	30 mm	30 mm
Rpm	4800	4000	3500	3000	2800

### Alternative equipment

Tool	Model	Saw blade
Festool	AXT 50 LA	TF56, 170 x 2.0 x 30 mm

### Slow running electrical equipment

Normally, slow moving electrical machinery develops heavy dust or chips. Cutting quality depends on the specific tool applied.

### Operation parameters for stationary circular saw

Saw blade Ø mm	150	230	250	260	300	350
Rpm	3800	2500	2300	2200	1900	1650

### Cut-outs

Cut-outs may be made with a jigsaw or a key-hole saw equipped with a hard metal, bi-metal or diamond tipped blade. In order to avoid creating a notch at the inside corner, it is recommended to drill a min 8 mm hole before cutting. Cut edges should be bevelled with sand paper.

# Storing, Handling and Processing

## Drilling

Drill holes from the front-side with a hard metal drill at 1500 rpm. Always, place an underlay, e.g. a woodchip-board, under the Cembrit board in order to achieve neat drilling holes. Cembrit recommends carbide tipped Irwin TCT twisted drill bit (DIN 338) which is available from Cembrit in 7-8-9 mm. The Irwin TCT drill will drill materials up to a hardness of 50 Rockwell C.

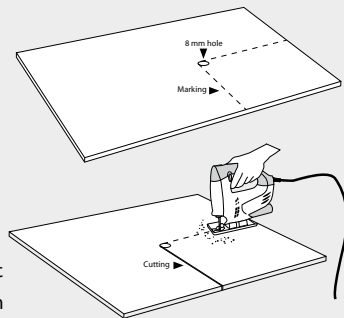

## Cleaning of boards after cutting and drilling

It is important immediately to remove dust caused by cutting and drilling from the front and back side of the boards with a soft brush/duster or a vacuum cleaner as it otherwise might damage the boards. Ensure that the boards are properly cleaned before installation, and if necessary use clean water or water with a mild detergent and a soft sponge or brush to remove dirt and dust from the surface. Thereafter, wipe the boards with a damp cloth. It may also be necessary to wash the surface after installation, if the building site conditions have been unfavourable. This is done with lots of clean water or water with a mild detergent and a soft sponge or brush and finally wiping the boards with a damp cloth.

## Removal of calcium based residues

Calcium carbonate residue may occasionally be seen on the board surface. This can be difficult to remove with water or even with detergents, because it does not dissolve in water. For cleaning purposes 10% acetic acid ( $\text{CH}_3\text{COOH}$ ) solution is used to dissolve the calcium compounds.

**Note!** Carefully observe safety precautions (MSDS) when working with acetic acid. R-phrase R36/R38 is valid: "Irritating to eyes, respiratory system and skin". Use proper clothing, nitrile rubber gloves, eye protection goggles and approved respirator (filter A, E or A/E). Carry out the mixing outdoors. Apply the diluted 10% acetic acid solution evenly with a spray can on the surface of the stained board. Leave it to react for a few minutes. Do not allow the solution to dry, but rinse with lots of clean water. Repeat the process if necessary and rinse with water afterwards.

**Note!** Do not execute the cleaning process with acetic acid in direct sunlight and on hot surfaces. This might create permanent stains in the surface paint.

## Cleaning of neighbouring areas

Windows and glass in particular but also other adjacent areas must be kept clean during the facade board installation and if necessary protected with plastic film. Alkaline leaching from cement bonded materials (dust from cutting or drilling holes in concrete basic wall, etc.) is prone to damage glass and other materials. Therefore, frequent cleaning during and after the construction period is needed.

## Surface damages and scratches

Damages and scratches should be avoided by lifting the boards off the pallet and handling them carefully during installation. Scratches might leave white streaks on the paint layer which will turn dark when exposed to rain, because the board absorbs water through the scratch. Repair paint is not available. The only way to prevent dark stripes or spots is to carefully apply clear Cembrit Edge Sealer onto the scratch with a thin brush.

In any case the dark area will diminish after 6 to 12 months, because of the carbonation reactions in the cement matrix of the board.

## Wet framing at edges or wet spots around screw holes

The principles for scratches also apply to cut edges: Carefully apply Cembrit Edge Sealer according to Cembrit instructions. Drill holes for screws and rivets can hardly be sealed, but Cembrit screws and rivets are equipped with sealing washers. When properly installed, the sealing washers will prevent water penetration into drill holes.

## Behaviour in wet conditions

Since the boards are made of Portland cement, their colour may turn darker when exposed to rain, if the board absorbs moisture through holes, scratches or insufficiently sealed edges. This is natural behaviour to any cement based product and it does not affect the integrity or long-term durability of the board. The original colour is restored as soon as the boards dry out. The darkening will show after heavy rainfall for the first months after installation. It will gradually reduce within 6 to 12 months, because the cement based matrix reacts with carbon dioxide from the atmosphere - carbonation - and thereby reduces water penetration.

# Storing, Handling and Processing

## Finishing of edges with Cembrit Universal Edge Sealer

### Product type

Solvent based clear edge sealer for Cembrit Zenit and Cembrit Metro.

### Usage

Cembrit Universal Edge Sealer must always be used to protect all unpainted edges of Cembrit Zenit and Cembrit Metro fibre cement boards. Factory cut edges are always painted. Only Cembrit Universal Edge Sealer should be used to protect the edges of Urbannature products.

### Surface preparation

After cutting, edges must be treated immediately with Cembrit Universal Edge Sealer. Board must be dry. Edges should be bevelled with fine grade sand paper and must be thoroughly cleaned from dust and dirt before applying the edge sealer.

### Application conditions

Board temperature and ambient temperature should be +5 °C - +30 °C and relative humidity <85 % . Process temperature must be min +5 °C.

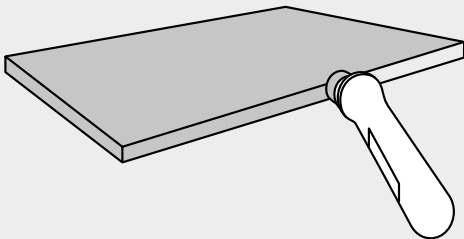

### Application

1. Shake the edge sealer can well before filling the applicator with edge sealer. Shake the filled applicator also before use if applicator unused for a while.
2. Remove the protective cap
3. Position the applicator horizontally
4. Place the sponge parallel to the board edge and run twice along the edge with a moderate pressure. Note! Carefully prevent the edge sealer to flow onto the front side of the board. Excess edge sealer on front side of the board must be wiped off immediately with a clean cloth
5. Check that the liquid has been applied over the entire edge surface
6. Close the applicator with the cap when interrupting the job
7. Replace the sponge when necessary

The boards can be handled 2 minutes after application of the edge sealer.

### Cleaning

No cleaning of equipment necessary. Unintended spillage can be cleaned with white spirit.

### Storage

Always keep the containers tightly closed and avoid direct exposure to sunlight. Store in a dry, cool and well ventilated place. Keep away from sources of ignition. No smoking. Shelf life is 6 months in unopened original packaging at cool temperatures. Can be stored at temperatures from -20 to +30 °C.

### Disposal

Disposal of the edge sealer must be in compliance with local and national regulations. Please refer to Material Safety Data Sheet.

### Safety measures

Please refer to Material Safety Data Sheet

# Maintenance

## Maintenance of installed boards

### Annual Inspection

Normally, a Cembrit facade does not require maintenance to maintain its strength, properties and function. Environmental impacts may, however, influence the visual appearance of the facade. Therefore, an annual inspection of the surface, ventilation gaps, joints and fixings is recommended. Detection and repair of possible damages secure a prolonged lifetime for the facade.

### Impact by Nature

The weather and nearby vegetation may affect the appearance of the facade. Pollution, dust and leaves from trees, bushes and flowers do all together have an impact on the facade. Cembrit facade products are manufactured by weather-resistant raw materials which reduces the risk of attack by algae, rot and dry rot.

### Cleaning

Cembrit facade boards can be cleaned with cold or lukewarm water, if necessary with the addition of a mild household detergent not containing solvents. Rinse with plenty of clean water until the facade is perfectly clean. Before cleaning full scale, it is recommended to test the selected cleaning method on a smaller area to make sure it answers its purpose.

### Moss and algae

Moss and algae growth can be removed with common detergents available on the market. Examples are hypochlorite (NaOCl e.g. trade mark: Klorin) that has no long-term effect or benzalconium-chloride (e.g. trade mark: Rodalon, BC50, BC80, BAC50, BAC80) 2.5% active that has a long-term effect preventing new growth. After wetting the facade with clean water, the agent is applied according to the supplier's instructions. Do not leave the agent to dry completely. Rinse with lots of clean water.

### High Pressure Cleaning

Warning! High Pressure Cleaning is a rough treatment of a fibre-cement cladding. Exaggerated or wrong use of a high pressure cleaner may damage the surface. Therefore, high pressure cleaning is not recommended.

## General Information

### Service

If you have any questions regarding the Cembrit facade boards, our dedicated employees are ready to assist you with advice and guidance. Please visit our website to ensure that these guidelines are the latest version.

### Warranty

Warranty conditions can be commissioned at your local Cembrit representative.

### Disclaimer

The information contained in this publication and otherwise supplied to users of Cembrit products is based on Cembrit's general experience, best knowledge and belief. However, because of factors that fall beyond Cembrit's knowledge and control, which can affect the use of the products, no warranty is given or implied with respect to such information.

Cembrit's policy is one of continuous improvement. Cembrit therefore reserves the right to alter specifications at any time and without notice. Colours and textures may vary according to light and weather conditions. Owing to this and limitations of the printing process, colours in this brochure may vary.

Please, ensure that you have the latest version of this publication by checking that the publication date corresponds with the downloadable version from our website. In case of doubt, please contact your local Cembrit representative.

# CEMBRIT

[www.cembrit.com](http://www.cembrit.com)

Please visit the local website for contact details and further information.

Cembrit is one of the leading European manufacturers of multi-capability fibre-cement building products. Our products and solutions add exciting new design opportunities for moulding attractive, durable settings for people's lives. But Cembrit is more than mere products. We also help make all kinds of design and construction projects easier – as well as more profitable, inspiring and effective. And for us, all construction also involves building relations with people, making your day better, and helping you make the day better for others. Making it a day to remember.