

Level Switches Catalogue

Level Switches



Overview

Techniquip Ltd
The Old Brewery
Norton Fitzwarren
Taunton
TA2 6RN
Tel 01823-351255
eMail sales@techniquip.co.uk
www.techniquip.co.uk



Control
Control
every move

Barksdale[®]
CONTROL PRODUCTS
CRANE Barksdale, Inc./Barksdale GmbH
A Subsidiary of Crane Co.

Overview	3
Introduction	3
Level Switches	8
UNS-VA 1/8 VA27 (-HT)	8
UNS-VA1/4 VA52 (-HT)	9
Bilge Level Switch	10
UNS-VA/SB4 Bilge Guard	10
UNS-VA/SB5 Bilge Guard	11
UNS-VA/SB1-VA52	12
UNS-VA/SB-VA52	13
Level Switches	14
UNS-PA16-PA18	14
UNS-PP16-PP18	15
UNS1000	16
UNS2000	20
Options	24

Introduction

Application

Where fluids must be stored or handled the Barksdale level switches with their large variety from a simple compact switch to multi level stations with lengths up to three meters are a logic choice (longer on request). When temperature and level measurement are required at the same time in tanks or reservoirs it is practical and economical to combine these in the level switches UNS1000 with temperature sensor and UNS2000 with additional temperature switch.

Level

All level switches are equipped with hermetically sealed reed switches. The contact is switched by an annular rod bar magnet which is positioned within the float.

The reed switch is available as normally closed, normally open or SPDT-contact. The only moving part of the level switch is the float sliding along the stem.

Contact modes (NO or NC) are defined on the basis of an empty tank and for installation through the top or through the bottom (when specified as "-U").

NO: (= Contact mode 1)

Normally open,

- Closing contact by rising level
- Opening contact by falling level

NC: (= Contact mode 2)

Normally closed,

- Opening contact by rising level
- Closing contact by falling level

The density (specific gravity) of the medium will influence the floating position of the float. In very light oils or solvents the float might change (lower) it's position up. If this is critical in your application consult us for details.

When not specified we will position the switch point for density 1 (water) and the switch action to be on moving upward.

Due to the hysteresis (dead band) of the reed contacts the action on rising level (reactuation point) will be several millimetres lower than the specified switch point.

Temperature Measuring (optional)

For temperature measurement we offer a PT 100 temperature sensor in our UNS1000 and UNS2000.

In the series UNS2000 we also offer temperature switch functions (TP) and the series UNS1000 with TS. The bi-metal element (TP and TS) are hermetically sealed, and are installed in the bottom of the stem.

The hysteresis of the TP type is only 3...10 K at mid range (depending on the operating temperature). The hysteresis of the TS type is 30 ±15 K.

Typical Applications for Level Switches with integrated Temperature Sensor

- ▶ switching on heaters to avoid freezing of the medium, or
- ▶ high or low temperature alarm in hydraulic tanks (TP type)

Type UNS2000 is also available with temperature switch and ATEX-approval.

(Other UNS-versions with ATEX-Ex ia on request)

Features and Benefits:

- ▶ Only moving part: The wearlessly working float.
- ▶ NO linkage, bellows or dynamic seals to wear, no service or spare parts needed.
- ▶ Easy to install, no calibration needed.
- ▶ Welded hollow floats in Stainless Steel and foamed floats in Buna-N (BN) are mostly used. The BN float is a closed cell Buna rubber, very light and very good in most hydrocarbons and water.
- ▶ Many special floats are available, consult us for details.
- ▶ The position of the float on the stem determines the contact status, open or close. By rotating the float the switch function will be reversed.
- ▶ Hysteresis of switch action only a few mm depending on type of contact and float.
- ▶ Reed contacts are designed to operate under vibration and are ideal for industrial applications.
- ▶ The UNS1000 and UNS2000 offer "custom made" specials at standard pricing.
- ▶ DNV-, GL- and BV-shipboard approvals with the series UNS1000 S, UNS2000 S and UNS-VA SB (ABS-, LR- und RINA-approvals on request).
- ▶ Option for high temperature -40 °C...+150 °C, specify -HT
- ▶ Option for splash or protection tube, specify: -DR
- ▶ Option for vertical adjustment, specify: -VV
- ▶ Option for additional temperature switch(es) specify: -TP,-TS
- ▶ Option for temperature sensor PT100, specify: -Pt100
- ▶ Mounting normally vertical downwards through the top, specify -U when mounting will be through the bottom vertical upwards. For pressures over 50 bar and/or very low density fluids we have special solutions, consult us for details.
- ▶ Many years of experience in level switches and many specials since, include many "exotics" in Hastelloy, Titanium, Plastic or Teflon, will help us to design the special version you might need.
- ▶ Approvals: see under www.barksdale.de

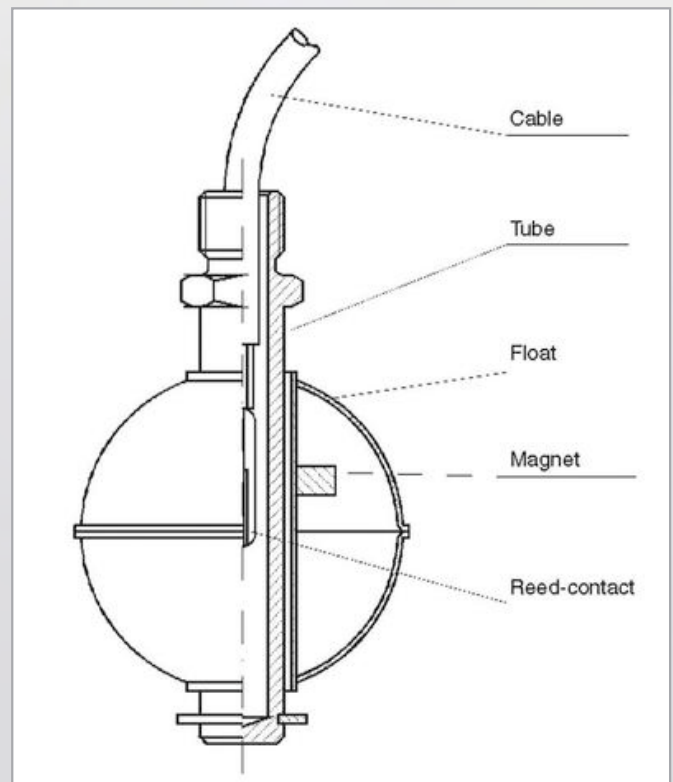

Introduction

General Technical Information

The indicated values for power, voltage and capacity are valid for purely resistive loads. Quite frequently though, the loads are surrounded by inductive and capacitive components. Very often lamp loads must be switched. In this case, protection of the reed switch against voltage and power peaks must be considered. Of course, each case must be evaluated separately. But we would like to give some guidelines concerning the wiring of reeds for different loads to avoid premature failure.

1. Inductive loads

Contact protection is relatively simple for direct current (DC). A free-wheel diode is wired parallel to the load. Polarity must be established in such a way that the diode will inhibit at normal operational voltage (current) and short-circuit the power peaks which occur in the opposite direction when the switch opens. (see fig. 1). It is not possible to use a diode for AC. Here an arc-dimming unit has to be used. Generally this unit is a RC-unit wired parallel to the switch and hence in series with the load. Sizing of such an arc-dimming unit can be performed according to the nomogram shown in fig. 2 and 3.

2. Capacitive loads and lamp loads

Contrarily to the inductive loads, there are inrush currents for capacitive loads and lamp loads which can lead to disturbance - even to the point of fusing of the contacts. During the wiring of loaded condensators (e.g. cable capacities) a sudden discharge will occur, with an intensity depending on the capacity and length of supply cable to the switch (can be regarded as series resistor). The discharge peak of the current is largely reduced by a series resistor to the condensator. Its size is determined by the possibilities offered by the respective power circuit. It should be as high as possible in order to limit the discharge current to a permitted value. These criteria are valid analogously for the charging of condensators (see fig. 4).

Finally we want to give some details regarding the wiring of lamp loads. Cold incandescent filaments (switched off) have ten times smaller resistance than switched on filaments. That means during switch-on - even for a short period of time only - the current flow is ten times higher than in glowing, static condition of the lamp. This tenfold inrush current can be reduced to an acceptable level by a continuously wired limiting resistor. Another possibility is the parallel wiring of a resistance to the switch. This will permanently heat up the switches of the lamp filament only so much as to just prevent it from glowing. Both protective modes result in the loss of capacity (see. fig 5).

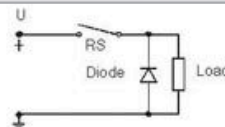

Fig. 1
Protection at DC and inductive load with free-wheeling diode.

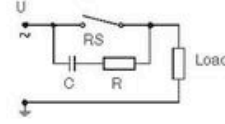

Fig. 2
Protection at AC and inductive load with free-wheeling diode.

Fig. 3

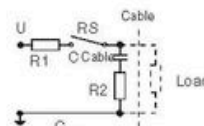
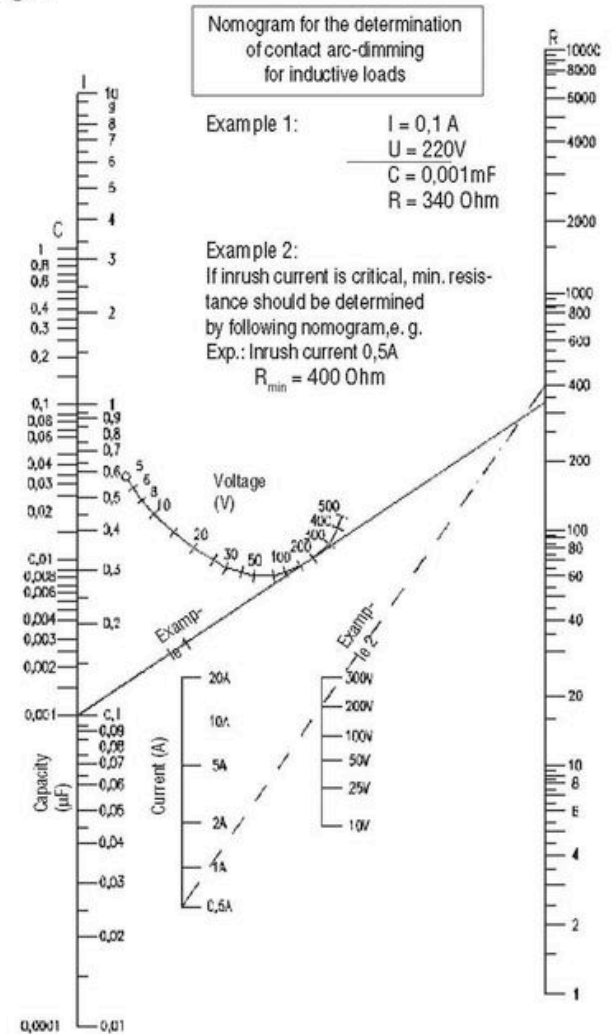

Fig. 4
Protection against high discharge current of condensers. Depends upon circuit R1 or R2 or both should be used.

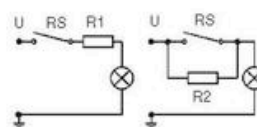

Fig. 5
Lamp loads with parallel or serial resistor to switch.

Overview



Model	UNS-VA1/4-VA52	UNS-VA / SB4 (without test function) UNS-VA / SB5 (with test function)	UNS-VA/SB1 (without test function) UNS-VA/SB (with test function)
Mounting Position	Through top Through bottom	Side mounted	Side mounted
Stem Material	Stainless Steel 1.4571	Stainless Steel 1.4571	Stainless Steel 1.4571
Mounting Element	G1/4 Mounting thread	Mounting bracket	Mounting bracket
Float	VA52, Ø = 52 mm	PE33, Ø = 33 mm	VA52, Ø = 52 mm
Float Material	Stainl. Steel 1.4571	Polyethylene PE	Stainless Steel 1.4571
Min. Fluid Specific Gravity (g/cm ³)	VA52: 0,78	0.8	0.7
Max. Pressure (bar)	40	3	10
Max. Temperature	105/150 °C - Stainl. Steel	70 °C	80 °C
Contact Mode	NO / NC WE	NO / NC	NO / NC WE
Contact Rating	100 VA/W NO / NC 60 VA/W / SPDT	40 VA/W NO / NC	100 VA/W / NO / NC 60 VA/W / SPDT
Option	High temperature version	Test equipment	Test equipment
Approval	on request, see www.barksdale.de	on request, see www.barksdale.de	on request, see www.barksdale.de

Overview



Model	UNS-PA16-PA18 UNS-PA1/2"NPT-PA18	UNS-PP16-PP18 UNS-PP1/2"NPT-PA18	UNS1000
Mounting Position	Side mounted	Side mounted	Through top Through bottom
Stem Material	Polyamide 6.6	Polypropylene	Brass Stainless Steel 1.4571
Mounting Element	M 16 x 2 1/2" NPT, G1/2	M 16 x 2 1/2" NPT	Flange and thread
Float	Ø = 18 mm	Ø = 18 mm	BN25, Ø = 25 mm VA27, Ø = 27 mm
Float Material	Polyamide 6.6	Polypropylene	Buna N Stainl. Steel 1.4571
Min. Fluid Specific Gravity (g/cm ³)	0.7	0.65	BN25: 0,57 VA27: 0,71
Max. Pressure (bar)	5	5	15
Max. Temperature	60 / 120 °C	60 / 90 °C	100 °C, NBR coated 105/150 °C - Stainl.Steel
Contact Mode	NO / NC	NO / NC	NO / NC SPDT
Contact Rating	60 VA/W	60 VA/W	40 VA/W NO / NC 5 VA/W / WE
Option	on request	on request	High temp. Version temperatur sensor
Approval	on request, see www.barksdale.de	on request, see www.barksdale.de	on request, see www.barksdale.de

Overview

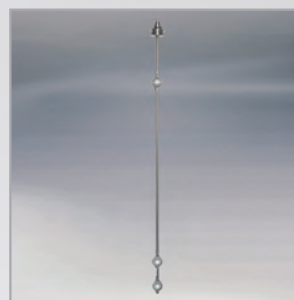

Model	UNS2000
Mounting Position	Through top Through bottom
Stem Material	Brass Stainless Steel 1.4571
Mounting Element	Flange and thread
Float	BN30, Ø = 30 mm VA52, Ø = 52 mm
Float Material	Buna N Stainl. Steel 1.4571
Min. Fluid Specific Gravity (g/cm³)	BN30: 0,60 VA52: 0,78
Max. Pressure (bar)	15 40
Max. Temperature	80/100 °C, NBR coated 105/150 °C - Stainl.Steel
Contact Mode	NO / NC SPDT
Contact Rating	100 VA/W NO / NC 60 VA/W / WE
Option	High temp. Version temperatur sensor
Approval	on request, see www.barksdale.de

Level Switches

UNS-VA 1/8 VA27 (-HT)

Made of Brass or Stainless Steel
with G1/8 - Mounting Thread

Technical Data

Stem and Mounting Thread	VA 1/8 = W.Nr. 1.4571, G1/8
Float	VA 27 = W.Nr. 1.4571, \varnothing 27 mm
Max. Operating Pressure	15 bar (Float / +20 °C)
Max. Operating Temperature	-10 °C...+105 °C, PVC-Cable -40 °C...+150 °C, Silicone cable (-HT)
Min. Fluid Specific Gravity	0,71 g/cm ³
Mounting Position	vertical, $\pm 30^\circ$, through top or bottom
Protection Class	IP54
Electrical Connection	PVC-cable, max.3 x 0,34 mm ² Silicone cable (-HT), max. 3 x 0,5 mm ² 1 m / 3 m / 5 m length
Contact Mode	1 - SPST-switch (NO) 2 - SPST-switch (NC) 3 - SPDT-switch
Max. Contact Rating	NO / NC: 230 V AC / DC 2 A, 40 VA / W SPDT: 150 V AC / 100 V DC, 0.2 A, 3 VA / W
Weight	appr. 90 g
Approval	www.barksdale.de

By turning the float upside down the function of the switch contact can be changed from NO (standard) in NC or vice versa. (Not possible with SPDT contacts)
The contact modes (NO or NC) are defined on the basis of an empty tank and for a level switch mounted through the top.

Order Code

Type	Contact Mode	Cable Type/Length	Order Number
UNS-VA1/8-K1-VA27/1(2)	NO (NC)	PVC / 1 m	0111-449
UNS-VA1/8-K3-VA27/1(2)	NO (NC)	PVC / 3 m	0111-450
UNS-VA1/8-K5-VA27/1(2)	NO (NC)	PVC / 5 m	0111-451
UNS-VA1/8-K1-VA27/3	SPDT	PVC / 1 m	0111-452
UNS-VA1/8-K3-VA27/3	SPDT	PVC / 3 m	0111-453
UNS-VA1/8-K5-VA27/3	SPDT	PVC / 5 m	0111-454
UNS-VA1/8-K1-VA27/1(2)-HT	NO (NC)	Silicone / 1 m	0111-455
UNS-VA1/8-K3-VA27/1(2)-HT	NO (NC)	Silicone / 3 m	0111-456
UNS-VA1/8-K5-VA27/1(2)-HT	NO (NC)	Silicone / 5 m	0111-457
UNS-VA1/8-K1-VA27/3-HT	SPDT	Silicone / 1 m	0111-458
UNS-VA1/8-K3-VA27/3-HT	SPDT	Silicone / 3 m	0111-459
UNS-VA1/8-K5-VA27/3-HT	SPDT	Silicone / 5 m	0111-460
UNS-VA1/8-NPT-K1-VA27/1(2)	NO (NC)	PVC / 1 m	0111-577
UNS-VA1/8-NPT-K3-VA27/1(2)	NO (NC)	PVC / 3 m	0111-578
UNS-VA1/8-NPT-K5-VA27/1(2)	NO (NC)	PVC / 5 m	0111-579
UNS-VA1/8-NPT-K1-VA27/3	SPDT	PVC / 1 m	0111-580
UNS-VA1/8-NPT-K3-VA27/3	SPDT	PVC / 3 m	0111-581
UNS-VA1/8-NPT-K5-VA27/3	SPDT	PVC / 5 m	0111-582

Dimensions (mm / inch)

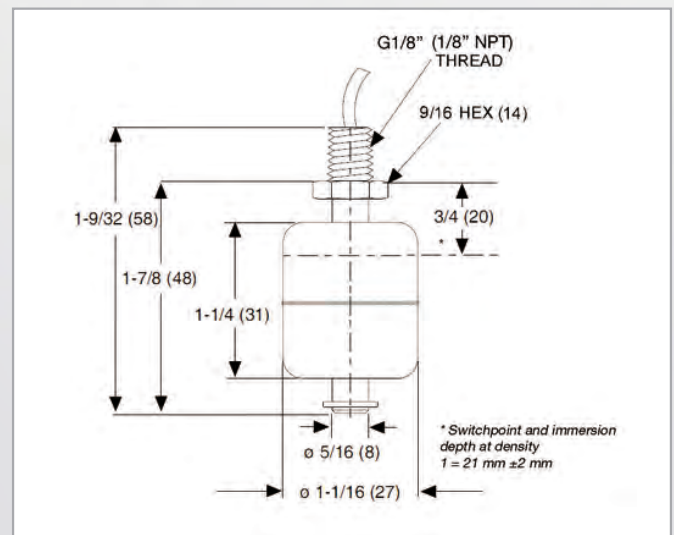

Color code

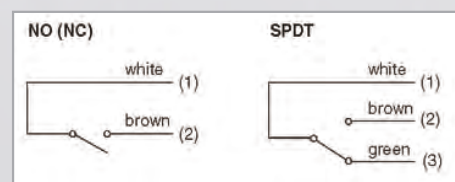

Level Switches

UNS-VA1/4 VA52 (-HT)

Made of Stainless Steel
with G1/4 - Mounting Thread

Technical Data

Stem and Mounting Thread	VA 1/4 = W.Nr. 1.4571, G1/4
Float	VA 52 = W.Nr. 1.4571, \varnothing 52 mm
Max. Operating Pressure	40 bar (Float / +20 °C)
Max. Operating Temperature	-10 °C...+105 °C, PVC-Cable -40 °C...+150 °C, Silicone cable (-HT)
Min. Fluid Specific Gravity	0,78 g/cm ³
Mounting Position	vertical, $\pm 30^\circ$, through top or bottom
Protection Class	IP54
Electrical Connection	PVC-cable, max. 3 x 0,34 mm ² Silicone cable (-HT), max. 3 x 0,5 mm ² 1 m / 3 m / 5 m length
Contact Mode	1 - SPST-switch (NO) 2 - SPST-switch (NC) 3 - SPDT-switch
Max. Contact Rating	1 - 250 V AC/DC / 3,0 A / 100 VA/W 2 - 250 V AC/DC / 3,0 A / 100 VA/W 3 - 140 V AC/DC / 1,0 A / 60 VA/W
Weight	appr. 150 g
Approval	www.barksdale.de

By turning the float upside down the function of the switch contact can be changed from NO (standard) in NC or vice versa. (Not possible with SPDT contacts)
The contact modes (NO or NC) are defined on the basis of an empty tank and for a level switch mounted through the top.

Dimensions (mm / inch)

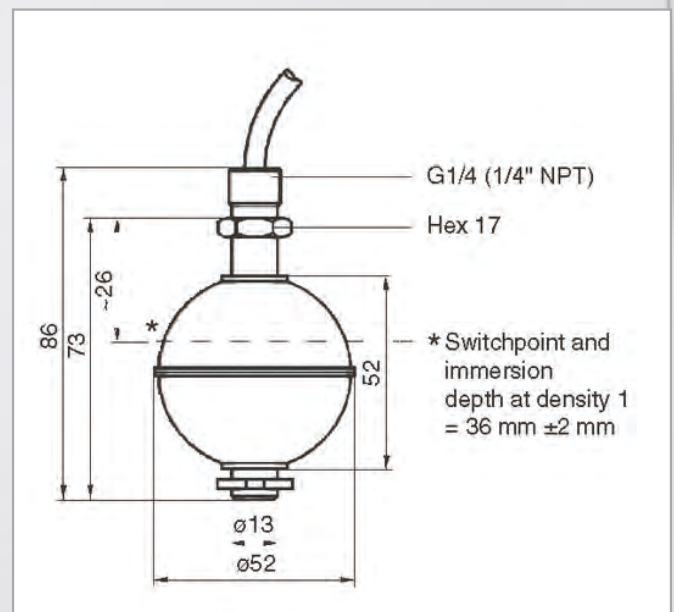

Order Code

Type	Contact Mode	Cable Type/Length	Order Number
UNS-VA1/4-K1-VA52/1(2)	NO (NC)	PVC / 1 m	0111-482
UNS-VA1/4-K3-VA52/1(2)	NO (NC)	PVC / 3 m	0111-483
UNS-VA1/4-K5-VA52/1(2)	NO (NC)	PVC / 5 m	0111-484
UNS-VA1/4-K1-VA52/3	SPDT	PVC / 1 m	0111-485
UNS-VA1/4-K3-VA52/3	SPDT	PVC / 3 m	0111-486
UNS-VA1/4-K5-VA52/3	SPDT	PVC / 5 m	0111-487
UNS-VA1/4-K1-VA52/1(2)-HT	NO (NC)	Silicone / 1 m	0111-488
UNS-VA1/4-K3-VA52/1(2)-HT	NO (NC)	Silicone / 3 m	0111-489
UNS-VA1/4-K5-VA52/1(2)-HT	NO (NC)	Silicone / 5 m	0111-490
UNS-VA1/4-K1-VA52/3-HT	SPDT	Silicone / 1 m	0111-491
UNS-VA1/4-K3-VA52/3-HT	SPDT	Silicone / 3 m	0111-492
UNS-VA1/4-K5-VA52/3-HT	SPDT	Silicone / 5 m	0111-493
UNS-VA1/4NPT-K1-VA52/1(2)	NO (NC)	PVC / 1 m	0111-589
UNS-VA1/4NPT-K3-VA52/1(2)	NO (NC)	PVC / 3 m	0111-590
UNS-VA1/4NPT-K5-VA52/1(2)	NO (NC)	PVC / 5 m	0111-591
UNS-VA1/4NPT-K1-VA52/3	SPDT	PVC / 1 m	0111-592
UNS-VA1/4NPT-K3-VA52/3	SPDT	PVC / 3 m	0111-593
UNS-VA1/4NPT-K5-VA52/3	SPDT	PVC / 5 m	0111-594

Color code

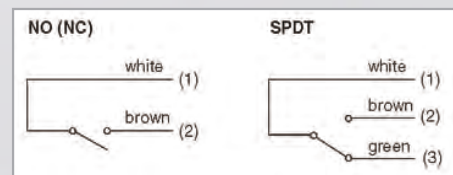

Bilge Level Switch

UNS-VA/SB4 Bilge Guard

Level switch without test function

Features

Rugged and sturdy design for bilge monitoring

Applications

Shipbuilding,
sewage works
yacht building

Technical Data

Materials:	
Stem, bracket and float chamber:	stainless steel
Float:	PE
Cable:	Polymer, halogen-free, UL-V0
Cap nut:	PA
Operating pressure:	max. 3 bar (float / +20 °C)
Temperature range:	max. -20 °C ... +70 °C
Fluid specific gravity:	min. 0.80 g/cm ³
Immersion depth:	
at density 1:	28 ±2 mm L1 ~18 mm
at density 0.8:	35 ±2 mm L1 ~11 mm
Mounting position:	vertical ±15°
Protection class:	IP67, IP68 on request (not shipyard approved)
Electrical connection:	Polymer cable, 2 x 0.75 mm ²
Cable length:	2 m / 5 m / 10 m / 15 m
Contact type*:	SPST switch (NO) (marking at bottom) By turning the float upside down: SPST switch (NC) (marking at top)
Contact rating:	max. 230 V AC / DC max. 2.0 A max. 40 VA / W
Weight:	approx. 175 g
Approvals:	GL, BV, ATEX on request

* The contact types (NO or NC) are defined on the basis of dry position of float and cable pointing vertically upwards.

Order Code

Type	Contact type	Cable type / length	Order No.
UNS-VA/SB4 Bilge Guard	NO (NC)	Polymer / 2m	0111-509
	NO (NC)	Polymer / 5m	0111-529
	NO (NC)	Polymer / 10 m	0111-660
	NO (NC)	Polymer / 15 m	0111-528



Dimensions (mm / inch)

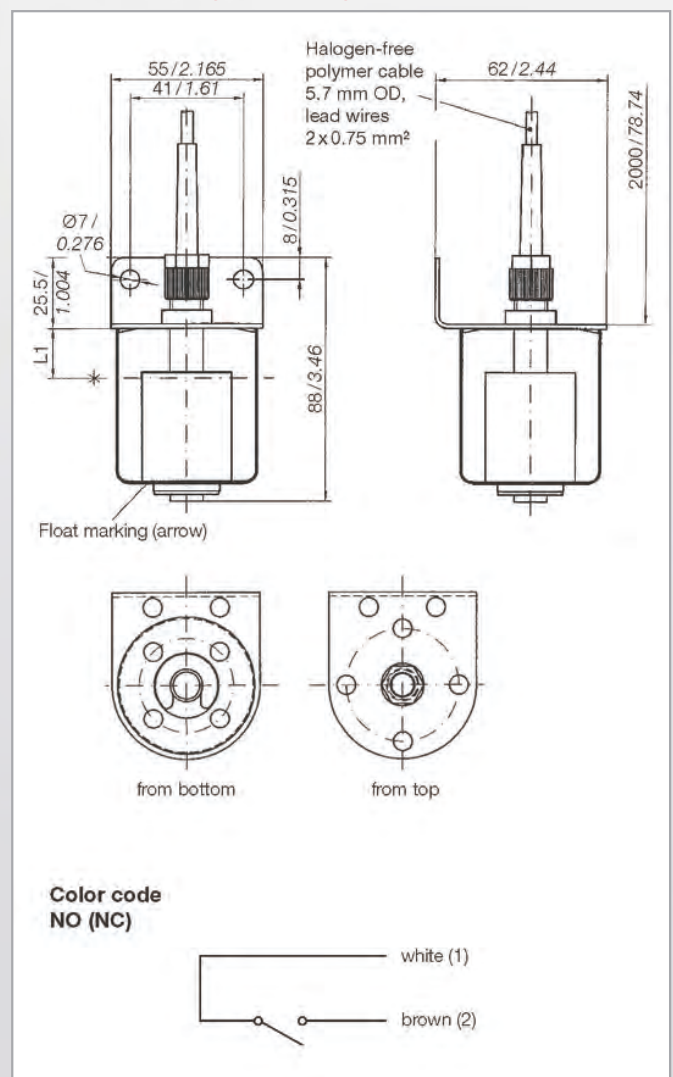

Bilge Level Switch

UNS-VA/SB5 Bilge Guard

Level switch with test function

Features

Rugged and sturdy design for bilge monitoring

Applications

Shipbuilding,
sewage works
yacht building

Technical Data

Materials:	
Stem, bracket and float chamber:	stainless steel
Float:	PE
Cable:	Polymer, halogen-free, UL-V0
Cap nut:	PA
Operating pressure:	max. 3 bar (float / +20 °C)
Temperature range:	max. -20 °C ... +70 °C
Fluid specific gravity:	min. 0.80 g/cm ³
Immersion depth:	
at density 1:	28 ±2 mm L1 ~18 mm
at density 0.8:	35 ±2 mm L1 ~11 mm
Mounting position:	vertical ±15°
Ingress protection:	IP67, IP68 on request (not shipyard approved)
Electrical connection:	Polymer cable, 2 x 0.75 mm ²
Cable length:	2 m / 10 m / 15 m
Contact type*:	SPST switch (NO) (marking at bottom) By turning the float upside down: SPST switch (NC) (marking at top)
Contact rating:	max. 230 V AC / DC max. 2,0 A max. 40 VA / W
Weight:	approx. 180 g
Approvals:	GL, BV, ATEX on request

* The contact types (NO or NC) are defined on the basis of dry position of float and cable pointing vertically upwards.

Order Code

Type	Contact type	Cable type/length	Order No.
UNS-VA/SB5 Bilge Guard Plus	NO (NC)	Polymer / 2 m	0111-510
	NO (NC)	Polymer / 5 m	0111-652
	NO (NC)	Polymer / 10 m	0111-531
	NO (NC)	Polymer / 15 m	0111-534



Dimensions (mm / inch)

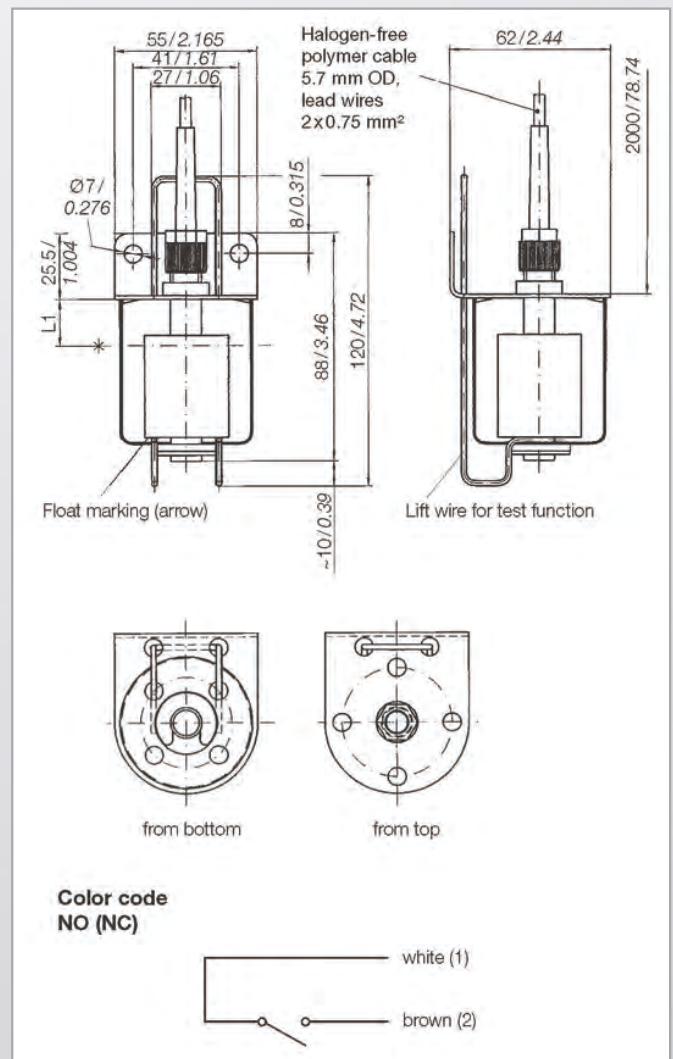

Bilge Level Switch

UNS-VA/SB1-VA52

Level switch without test function

Features

Particularly rugged and sturdy design for bilge monitoring

Applications

Shipbuilding,
sewage works



Technical Data

Stem, housing and screw coupling:	stainless steel 1.4571
Ball float:	VA52, Ø = 52 mm
Operating pressure:	max. 10 bar
Temperature range:	max. -20 °C ... +80 °C
Fluid specific gravity:	min. 0.70 g/cm ³
Attachment:	Holding bracket
Protection class:	IP67
Electrical connection:	Shipbuilding or marine cable
Cable length:	2 m (standard), 5 m, 10 m
Contact:	1: normally open contact (NO) 2: normally closed contact (NC) 3: change-over contact (WE)
Contact rating:	1: 250 V AC/DC / 3.0 A / 100 W / VA 2: 250 V AC/DC / 3.0 A / 100 W / VA 3: 140 V AC/DC / 1.0 A / 60 W / VA
Weight:	approx. 735 g
Approvals:	GL, BV and RMRS (RINA, ABS and LR on request)

Dimensions (mm / inch)

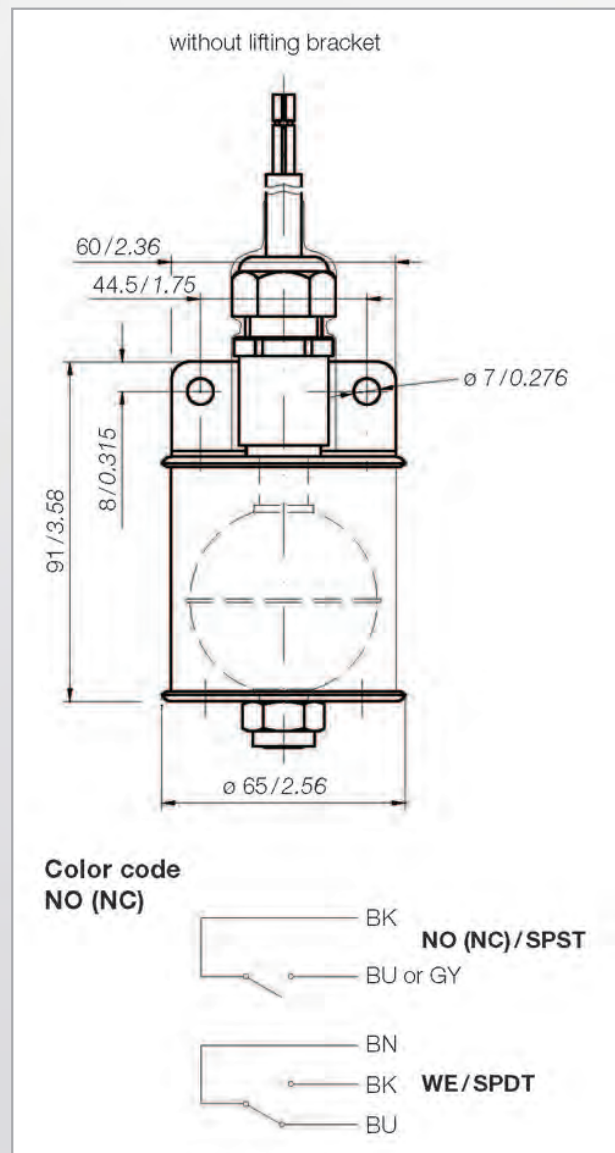

Order Code

Type	Contact type	Cable length	Order No.
UNS-VA/SB1-VA52	NO (NC) SPST	2 m	0111-623
		5 m	0111-624
		10 m	0111-625
	WE SPDT	2 m	0111-629
		5 m	0111-630
		10 m	0111-631

Bilge Level Switch

UNS-VA/SB-VA52

Level switch with test function

Features

Particularly rugged and sturdy design for bilge monitoring

Applications

Shipbuilding
Sewage works



Technical Data

Stem, housing and screw coupling:	stainless steel 1.4571
Ball float:	VA52, Ø = 52 mm
Operating pressure:	max. 10 bar
Temperature range:	max. -20 °C ... +80 °C
Fluid specific gravity:	min. 0.70 g/cm ³
Attachment:	Holding bracket
Protection class:	IP67
Electrical connection:	Shipbuilding or marine cable
Cable length:	2 m (standard), 5 m, 10 m
Contact:	1: normally open contact (NO) 2: normally closed contact (NC) 3: change-over contact (WE)
Contact rating:	1: 250 V AC/DC / 3.0 A / 100 W / VA 2: 250 V AC/DC / 3.0 A / 100 W / VA 3: 140 V AC/DC / 1.0 A / 60 W / VA
Weight:	approx. 735 g
Approvals:	GL, BV, RMRS (RINA, ABS and LR on request)

Dimensions (mm / inch)

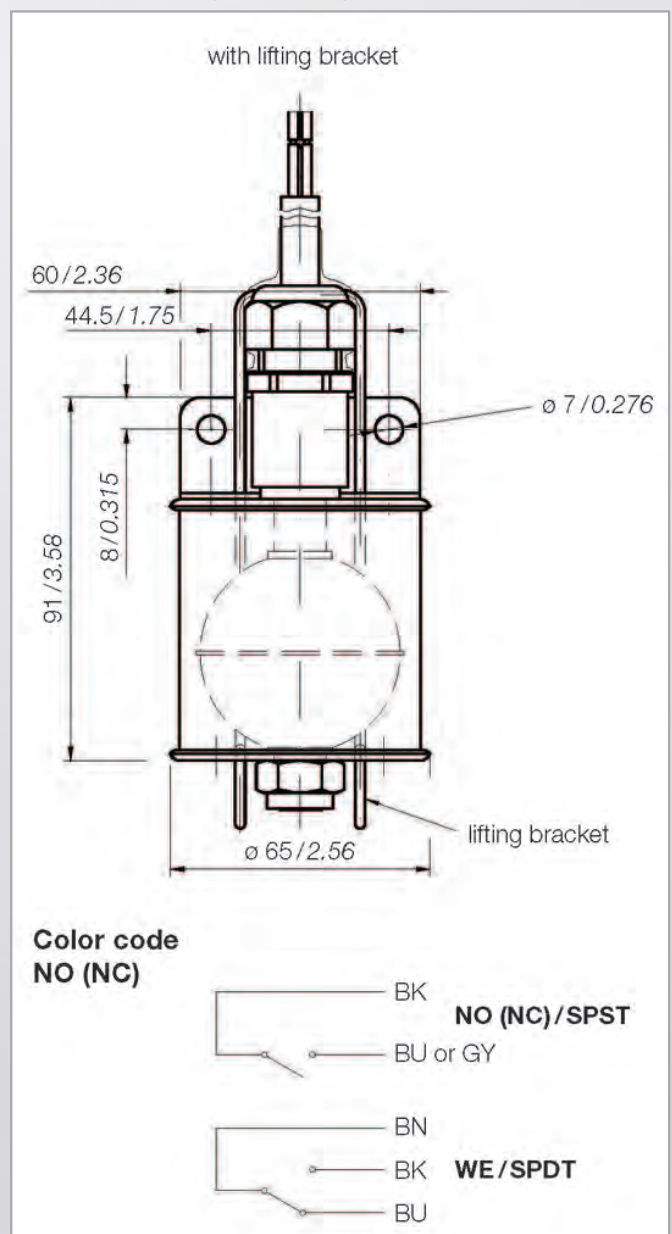

Order Code

Type	Contact type	Cable length	Order No.
UNS-VA/SB-VA52	NO (NC) SPST	2 m	0111-626
		5 m	0111-627
		10 m	0111-628
	WE SPDT	2 m	0111-558
		5 m	0111-565
		10 m	0111-567

Made of Polyamide for Side Mounting

Technical Data

Float and Fitting	Polyamide 6.6 (colour: blue)
Gasket	Silicone (at M 16 x 2.0 AG)
Mounting Element	PA16 = Polyamide, M 16 x 2.0 AG (Mounting thread with silicone gasket) PA1/2" NPT = Polyamide, 1/2" NPT Thread
Float	PA18 = Polyamide, $\varnothing = 18$ mm
Max. Operating Pressure	5 bar (depends on temperature)
Max. Operating Temperature	-20 °C...+120 °C (Medium) -20 °C...+60 °C (Ambient)
Min. Fluid Specific Gravity	0,70 g/cm ³
Mounting Position	Horizontal
Protection Class	IP54
Electrical Connection	PVC-cable, max. 2 x 0,34 mm ² , 1 m length
Contact Mode	1: SPST-switch (NO) (Marking on top / arrow down) 2: SPST-switch (NC) (Marking on bottom / arrow up)
Contact Rating	230 V AC/DC / 3,0 A / 60 VA/W
Weight	appr. 40 g
Max. Starting Torque	2,67 Nm Only UNS-PA16-PA18

Order Code

Type Contact	Contact Mode	Cable Type/Length	Order Number
UNS-PA16/PA18	NO (NC)	PVC / 1 m	0111-199
UNS-PA 1/2' NPT-PA18	NO (NC)	PVC / 1 m	0111-203

Dimensions (mm / inch)

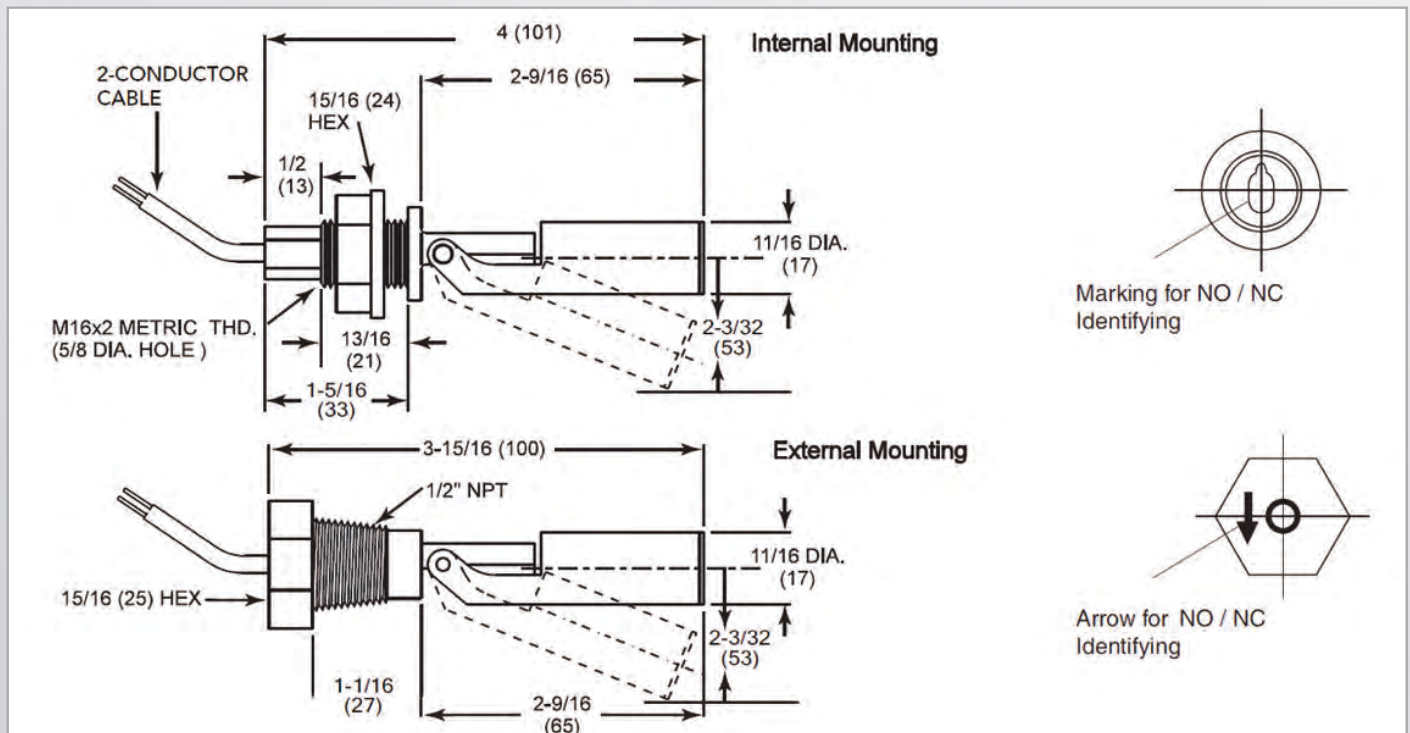

Level Switches

UNS-PP16-PP18

Made of Polypropylene for Side Mounting

Technical Data

Float and Fitting	Polypropylene (colour: red)
Gasket	Silicone (at M 16 x 2.0 AG)
Mounting Element	PP16 = Polypropylene, M 16 x 2.0 AG , (Mounting thread with silicone gasket) PP1/2" NPT = Polypropylene, 1/2" NPT Thread
Float	PP18 = Polypropylene, $\varnothing = 18$ mm
Max. Operating Pressure	5 bar (depends on temperature)
Max. Operating Temperature	-20 °C...+90 °C (Medium) -20 °C...+60 °C (Ambient)
Min. Fluid Specific Gravity	0,65 g/cm ³
Mounting Position	Horizontal
Protection Class	IP54
Electrical Connection	PVC-cable, max. 2 x 0,34 mm ² , 1 m length
Contact Mode	1: SPST-switch (NO) (Marking on top / arrow down) 2: SPST-switch (NC) (Marking on bottom / arrow up)
Contact Rating	230 V AC/DC / 3,0 A / 60 VA/W
Weight	appr. 40 g
Max. Starting Torque	2,67 Nm Only UNS-PP16-PP18

Order Code

Type Contact	Contact Mode	Cable Type/Length	Order Number
UNS-PP16/PP18	NO (NC)	PVC / 1 m	0111-210
UNS-PP1/2"NPT-PP18	NO (NC)	PVC / 1 m	0111-327

Dimensions (mm / inch)

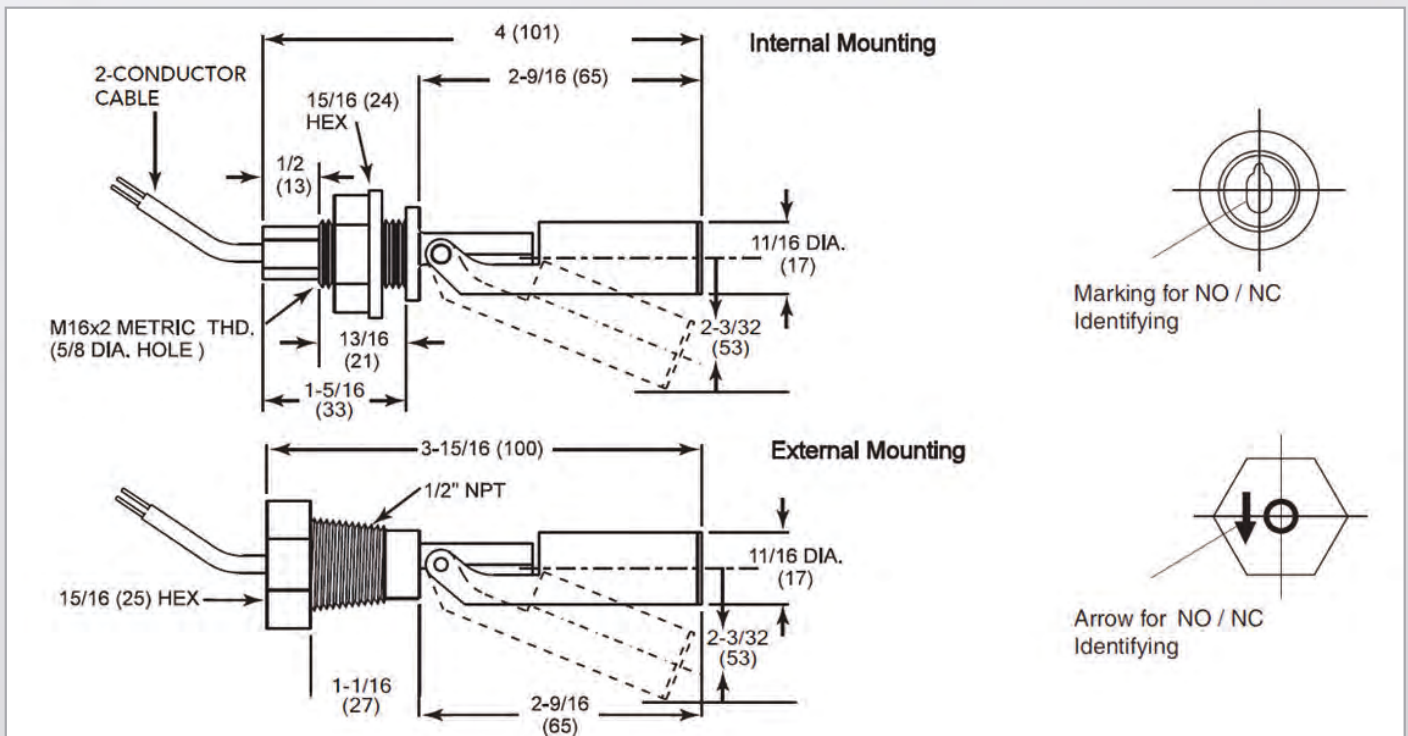

Level Switches

UNS1000

Function

The multi Level Switch Series UNS1000 can be supplied with up to 5 switchpoints (see "Max. Switchpoints"). Besides the float operated reed contacts to detect liquid levels, the UNS1000 can be supplied also with a PT100 temperature sensor or with a temperature switch TS.

A wide selection of mounting elements, electrical connections, various materials and options allow you to "design" your own switch, within the given dimension limits, for your particular application. (see "Order code") The min. dimensions are based upon the medium water. Depending on the density of other fluids this dimension can vary several millimeters. The contact modes (NO or NC) are defined on the basis of an empty tank and for installation through the top or through the bottom (when specified as "-U"). When not specified otherwise we will set the switch position for density 1 (water) and the switch action to be on moving upward.

Max. temperature range: -10°C...+105°C (Standard),
Option: -40°C...+150°C, Silicone cable (-HT)

The mounting position should be vertical, ±30°, though top or bottom.



Technical Data

Max. Operating Pressure:	15 bar, BN25, VA27 and VA44 float, 4 bar, BN18 float
Max. Temperature Range:	-10 °C...+105 °C, PVC-cable -40 °C...+150 °C, Silicone cab. (-HT)
Min. Fluid Specific Gravity:	See specifications below
Mounting Position:	Vertical, ±30°, through top or bottom
Protection Class:	IP54: ST2, K (Si-cable) IP65: ST1, KL6, KL12, PG, K (PVC cable) IP67, IP68: on request
Weight:	Depends on length and design
Options:	See order code

Max. Switchpoints

	KL6	KL12	ST1	ST2	Pg Cable connect.
Connect. group 1	5	5	2	5	3
Connect. group 2	2	4	1	2	1
Connect. group 3	3	4	1	3	2
Connect. group 4	2	3	1	2	1

*not valid for "HT" option

Contact Wiring

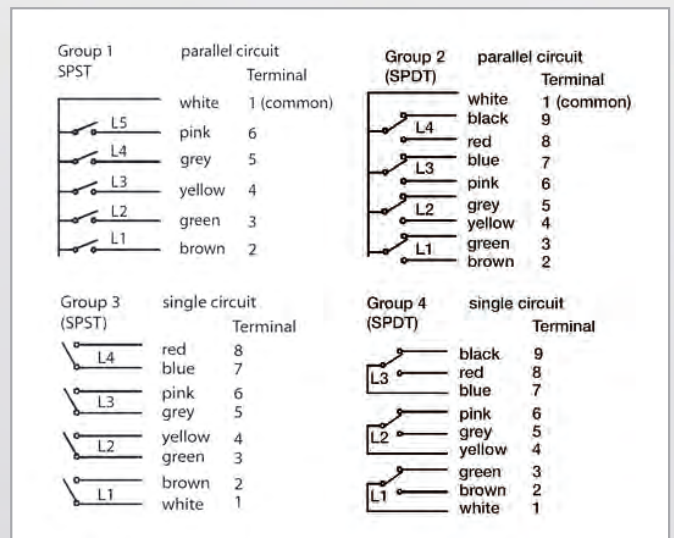

Level Switches

UNS1000

Dimensions (mm / inch)

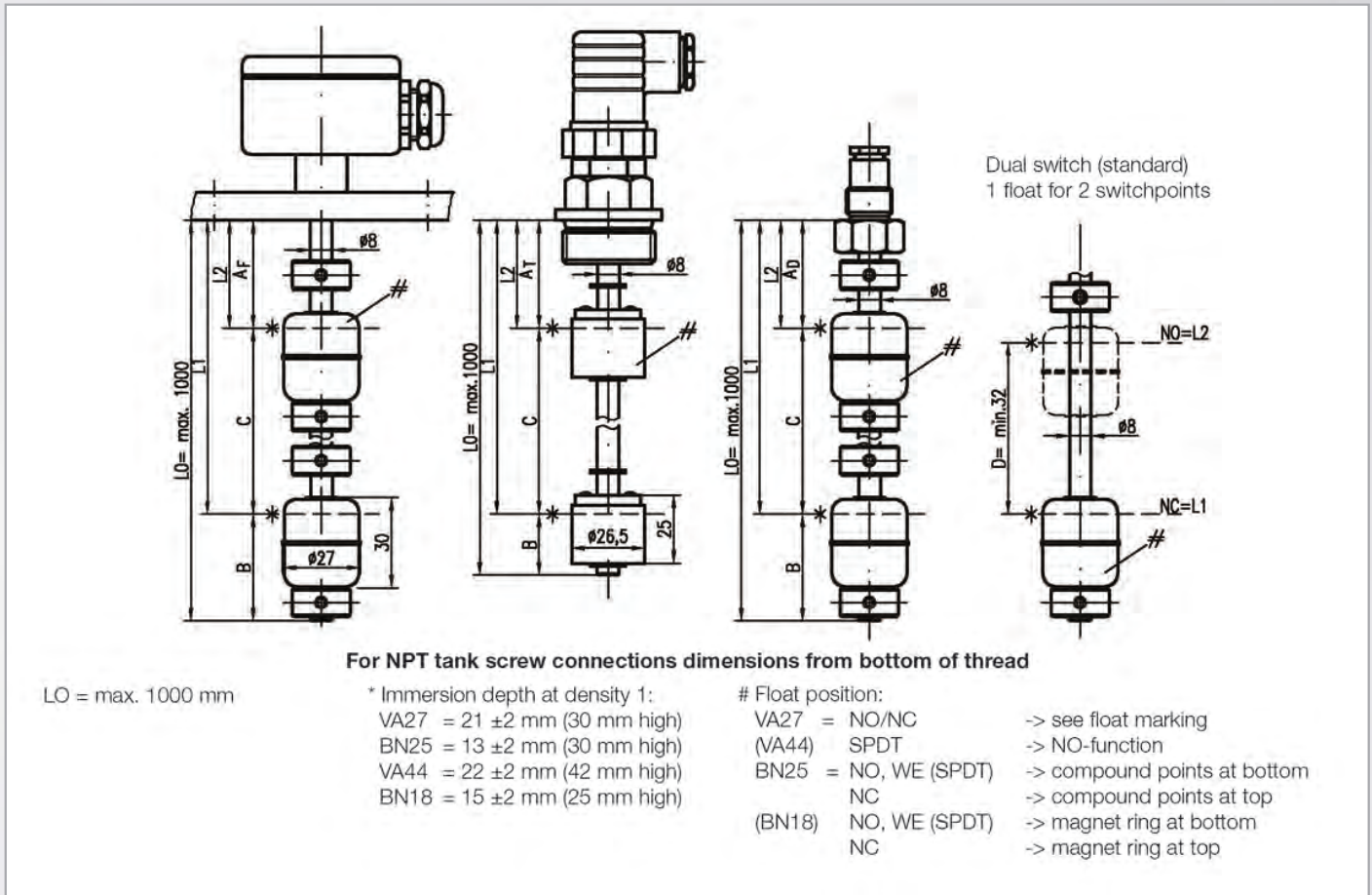

Switch Point Dimensions

Dimensions	Min. distances in mm								
	A _F	A _{T1}	A _D	B	B _{PT}	B _{TS}	B _{DR}	C	D
VA27	26	42	38	40	50	55	60	65	32
BN25/BN18	22	37	34	25	35	40	45	45	32
VA44	36	52	48	35	45	50	55	70	32

B_{PT} = first switch point with option PT100 (mounting on bottom)

B_{TS} = first switch point with option TSxx/2 (mounting on bottom)

Level Switches

UNS1000

Brass Version

Order Code

Type:

UNS1000

Material of Stem and Mounting Element:

MS - Brass, CW614N / CW508L (former Ms58 / Ms63)

Mounting Element (other on request)

- 1/8 - G1/8" mounting thread for inside mounting: only with cable (K)
- 3/8 - G3/8" mounting thread for inside mounting: only with (PG) or (K)
- T1/2 - G1/2" tank screw, only with BN18 float
- T1 - G1" Tank screw (not with VA44 float)
- M20x1,5 - Tank screw M20x1,5 mm (only BN18)
- T1NPT - 1"NPT-Tank screw (not with VA44 float)

Electrical Connection (see table max. Switchpoints)

- ST1 - Cube Plug DIN EN 175301-803-A (former DIN 43650), 3-pin + ground, IP65 with mating plug
- ST2 - Angle Plug DIN 43651, 6-pin + ground, IP54 with mating plug
- M12x1 - M12x1 mm plug, 4-pin, IP65, without mating plug
- KL6 - Aluminum Terminal Box, 6 Terminals, IP65
- KL12 - Aluminum Terminal Box, 9 Terminals, IP65
- PG - Cable Gland with 1 m PVC-cable, other length on request, IP65
- K - PVC-Cable sealed, specify length at order, IP65

(Others on request)

Float type	min.Density Medium	Material	Form	Dia-meter	max. Temp.	max. Pressure (+20 °C)
BN25	0,57 g/cm3	NBR foamed	Cylinder	25 mm	100 °C	15 bar
BN18	0,64 g/cm3	NBR foamed	Cylinder	18 mm	100 °C	4 bar

Number of Switchpoints

- L1 = 1 Switchpoint
- L2 = 2 Switchpoint
- L3 = 3 Switchpoint
- L4 = 4 Switchpoint
- L5 = 5 Switchpoint

See also "Connections Groups" in table "Max. Switchpoints"

Contact Modes

Contact Rating

- 1 - SPST (NO) 230 V AC / DC, 2 A, 40 VA / W
- 2 - SPST (NC) 230 V AC / DC, 2A, 40 / W
- 3 - SPDT (WE) 150 V AC, 100 V / DC, 0.2 A, 3 VA / W

Basic: empty tank

Total Length: L0 = ...mm (max. 1000 mm)

Specify with your order: L1 = ...mm, L2 = ...mm, etc

UNS1000 - MS/ T1 -KL6 -BN25 - L2/ 2.1 (Example)

Needed order information, e.g.:

L0 = 215 mm

L1 = 185 mm NC

L2 = 140 mm NO

Connection group: 3

(see table "max. Switching point/Connection code")

Options:

U = Mounting through bottom

VV = Vertical Adjustment (max. 5bar)

PT100 = Pt100-Sensor

TSxx/2 = Temperature Switch TS, Contact Rating: 24 V AC/DC 1A, 20 VA / W

xx = Standard: +60 °C, +70 °C, +80 °C, +90 °C

/2 = NC

Exi = ATEX Ex ia (intrinsically safe) Approval, see www.barksdale.de

DR = Damping Tube

HT = High Temperature Application (-40 °C...+100 °C), cable and wires in silicone

DUAL = one float with two level switch points

VA Version

Order Code

Type:

UNS1000

Material of Stem and Mounting Element:

VA = stainless steel 1.4571

Mounting Element (other on request)

- 1/8 - G1/8" mounting thread for inside mounting: only with cable (K)
- 3/8 - G3/8" mounting thread for inside mounting: only with (PG) or (K)
- T1/2 - G½" Tank screw, only with BN18 float
- T1 - G1" Tank screw (not with VA44 float)
- T1.5 - G1½" Tank screw
- FL2 - Flange DIN 2527, DN 32/PN16, (not with VA44 float)
- FL3 - Flange DIN 2527, DN 50/PN16
- FLA3 - Flange ASME 16.5, 2" 150lbs, RF
- T1NPT - 1"NPT-Tank screw (not with VA44 float)

Electrical Connection (see table max. Switchpoints)

- ST1 - Cube Plug DIN EN 175301-803-A (former DIN 43650), 3-pin + ground, IP65 with mating plug
- ST2 - Angle Plug DIN 43651, 6-pin + ground, IP54 with mating plug
- M12x1 - M12x1 mm plug, 4-pin, IP65 without mating plug
- KL6 - Aluminum Terminal Box, 6 Terminals, IP65
- KL12 - Aluminum Terminal Box, 9 Terminals, IP65
- PG - Cable Gland with 1 m PVC-cable, other length on request, IP65
- K - PCV-Cable sealed, specify length at order, IP54

(Others on request)

Float type	min.Density Medium	Material	Form	Dia-meter	max. Temp.	max. Pressure (+20 °C)
VA27	0,71 g/cm3	Stainl. Steel 1.4571	Cylinder	27 mm	150 °C	15 bar
VA44	0,67 g/cm3	Stainl. Steel 1.4571	Ball	44 mm	150 °C	15 bar

Number of Switchpoints

- L1 = 1 Switchpoint
- L2 = 2 Switchpoint
- L3 = 3 Switchpoint
- L4 = 4 Switchpoint
- L5 = 5 Switchpoint

See also "Connections Groups" in table "Max. Switchpoints"

Contact Modes

Contact Rating

Order:L1, L2, L3, L4, L5

- 1 - SPST (NO) 230 V AC / DC, 2 A, 40 VA / W
- 2 - SPST (NC) 230 V AC / DC, 2 A, 40 VA / W
- 3 - SPDT (WE) 150 V AC, 100 V / DC, 0.2 A, 3 VA / W

Basic: empty tank

Total Length: L0 = ...mm (max. 1000 mm)

Specify with your order: L1 = ...mm, L2 = ...mm, etc

UNS1000 - VA/ - T1 -KL6 -VA27 L2/ 2.1 (Example)

Options:

- U = Mounting through bottom
- HT = High Temperature Application (-40 °C...+150 °C), cable and wires in silicone
- DR = Damping Tube
- W = Vertical Adjustment (max. 5bar)
- PT100 = Pt100-Sensor
- Exi = ATEX Ex ia (intrinsically safe) Approval, see www.barksdale.de
- DUAL = One float with two level switch points

Needed order information e.g.:

- L0 = 200 mm
- L1 = 150 mm NC
- L2 = 85 mm NO
- Connection group: 3
- (see table "max. Switching point/Connection code")

Level Switches

UNS2000

The multi Level Switch Series UNS2000 can be supplied with up to 6 switchpoints (see max. switchpoints) and with a length of max 3000 mm.

Besides the float operated reed contacts to detect liquid levels, the UNS 2000 can be supplied also with a temperature sensor and/ or temperature contact(s), which are to handle as switchpoint(s) - please note max. switchpoints! A wide selection of mounting elements, electrical connections, various materials and options allow you to "design" your own switch, within the given dimension limits, for your particular application. Very long units or large flanges can cause high shipping and installation costs and "split" versions might be the answer. Consult us for the best combination. The min. dimensions are based upon the medium water.

Depending on the density of other fluids this dimension can vary several millimetres. The contact modes (NO or NC) are defined on the basis of an empty tank and for installation through the top or through the bottom (when specified as "-U"). When not specified otherwise we will set the switch position for density 1 (water) and the switch action to be on moving upward. Temperature sensor (PT100) and/ or the temperature switch, a Bi-metall hermetically sealed element, are installed only in the bottom of the stem.

That means:

Dimensions B + 10 mm with temperature sensor PT100) = B_{PT}

Dimensions B + 40 mm temperature switch (TP) = B_{TP}



Technical Data

Max. Operating Pressure:	40 bar, depends on mounting element and float
Max. Temperature Range:	-10 °C...+105 °C, PVC-cable -40 °C...+150 °C, Silicone cab.(-HT) and KL6 / KL12
Min. Fluid Specific Gravity:	See specifications below
Mounting Position:	Vertical, ±30°, through top or bottom
Protection Class:	IP65 for ST-, KL- and PG-design, IP67, IP68 on request IP54 for K-design
Weight:	Depends on length and design
Options:	See order code

Contact Wiring

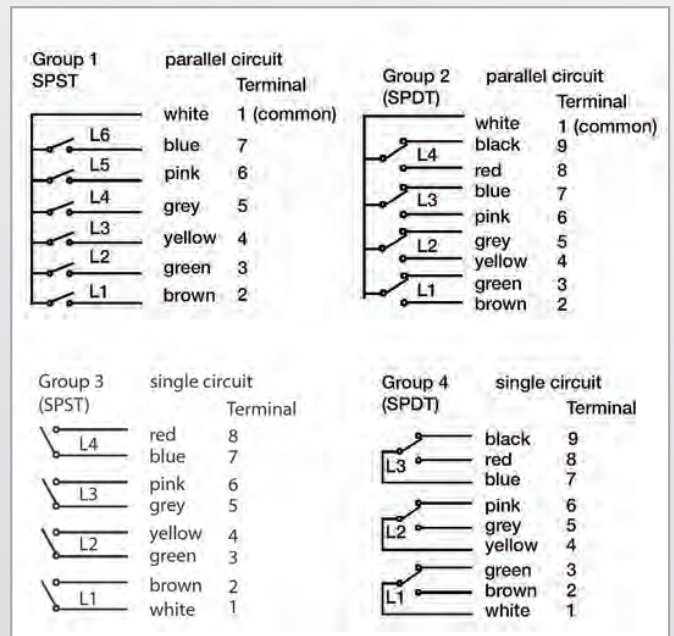

Max. Switchpoints

	KL6	KL12	ST1	ST1	Pg Cable connect.
Connect. group 1	5	6	2	5	6
Connect. group 2	2	4	1	2	4
Connect. group 3	3	4	1	3	4
Connect. group 4	2	3	1	2	3

*not valid for "HT" option

Level Switches

UNS2000

Dimensions (mm / inch)

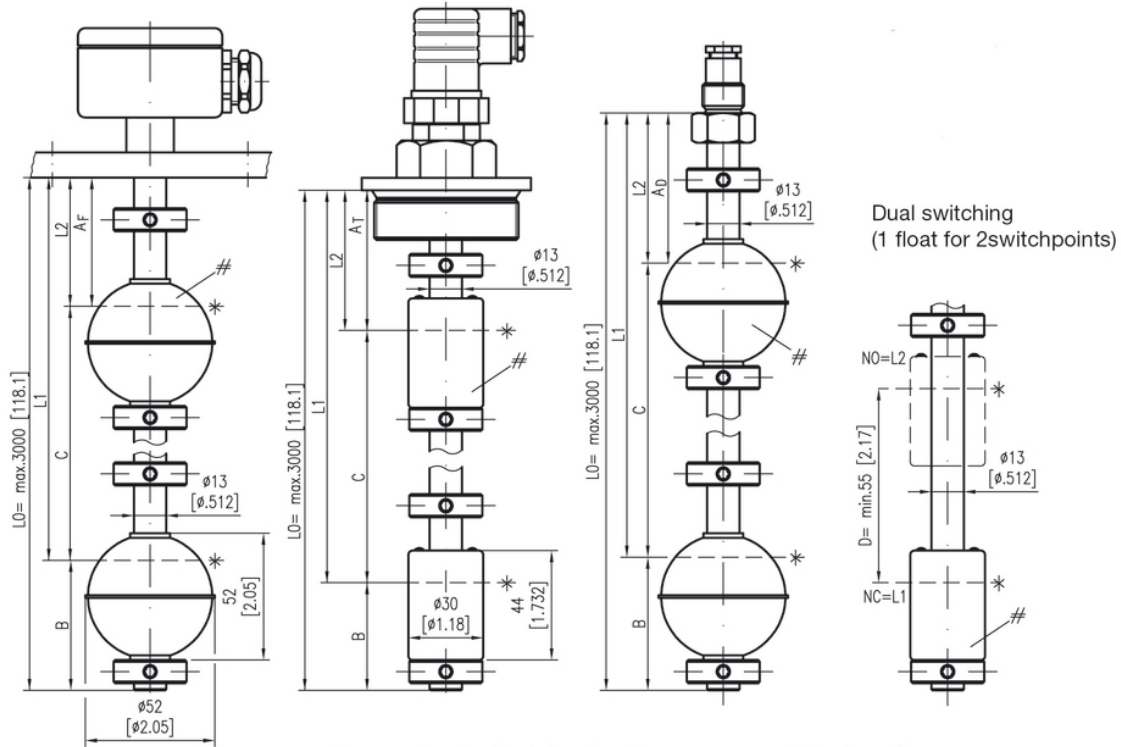

L0 = max. 3000 mm
For NPT thread tank fittings all lengths from bottom edge.

* Immersion depth at density 1:
 VA52 = 36 ± 2 mm
 BN30 = 20 ± 2 mm
 VA44 = 36 ± 2 mm (52 mm high)
 VA80 = 36 ± 2 mm (80 mm high)

Float position
 VA52 = NO/NO ⇨ see float marking
 WE ⇨ NO-function
 BN30 = NO ⇨ compound points at bottom
 NC ⇨ compound points at top
 WE ⇨ compound points at bottom

Switch Point Dimensions

Dimensions	Min. distances in mm								
Float type	A F	AT	A D	B	BPT	BTP	BDR	C	D
VA52, VA44	32	52	44	55	65	95	75	85	55
BN30	30	60	52	39	49	79	59	77	55
VA80	63	83	75	60	70	100	80	115	55

BPT = first switch point with option PT100 (mounting on bottom)
 BTP = first switch point with option TPxx/2 (mounting on bottom)

Level Switches

UNS2000

Brass Version

Order Code

Type:
UNS2000

Material of Stem and Mounting Element:
MS = Brass, CW614N / CW508L (former Ms58 / Ms63)

Mounting Element (other on request)
 3/8 - G3/8" mounting thread for inside mounting: only with PG
 T1 - G1" Tank screw (only with BN18 float)
 T2 - G2" Tank screw (not with VA80 float)
 T2NPT - 2"NPT-Tank screw (not with VA80 float)

Electrical Connection (see table max. Switchpoints)
 ST1 - Cube Plug DIN EN 175301-803-A (former DIN 43650), 3-pin + ground, IP65 with mating plug
 ST2 - Angle Plug DIN 43651, 6-pin + ground, IP54 with mating plug
 M12x1 - M12x1 mm plug, 4-pin, IP65 without mating plug
 KL6 - Aluminum Terminal Box, 6 Terminals, IP65
 KL12 - Aluminum Terminal Box, 9 Terminals, IP65
 PG - Cable Gland with 1 m PVC-cable, -HT with silicon cable, other length on request, IP65
 K - PVC-Cable sealed, specify length at order, IP65
 (Others on request)

Float type	min.Density Medium	Material	Form	Dia-meter	max. Temp.	max. Pressure (+20 °C)
BN30	0,6 g/cm ³	NBR foamed	Cylinder	30 mm	100 °C (oil) 80 °C (water)	15 bar

Number of Switchpoints
 L1 = 1 Switchpoint
 L2 = 2 Switchpoint
 L3 = 3 Switchpoint
 L4 = 4 Switchpoint
 L5 = 5 Switchpoint
 L6 = 6 Switchpoint

See also "Connections Groups" in table "Max. Switchpoints"

Contact Modes	Contact Rating	Order:L1, L2, L3, L4, L5, L6
1 - SPST (NO)	250 V AC / DC, 3 A, 100 VA / W	Basic: empty tank
2 - SPST (NC)	250 V AC / DC, 3 A, 100 VA / W	
3 - SPDT (WE)	140 V AC / DC, 1 A, 60 VA / W	

Total Length: L0 = ...mm (max. 3000 mm)
 Specify with your order: L1 = ...mm, L2 = ...mm, etc

UNS2000 - MS/ T1 -KL6 -BN30 -L2/ 2.1 (Example)

Options:
 U = Mounting through bottom
 HT = High Temperature Application (-40 °C...+150 °C), cable and wires in silicone
 DR = Damping Tube
 VW = Vertical Adjustment (max. 5 bar)
 PT100 = Pt100-Sensor
 TPxx/2 = Temperature Switch TP, Contact Rating: 3A, 12 or 24 V DC
 xx = Standard: +50 °C, +60 °C, +70 °C, +80 °C, +90 °C
 /2 = NC
 Exi = ATEX Ex ia (intrinsically safe) Approval, see www.barksdale.de

Needed order information e.g.:
 L0 = 200 mm
 L1 = 161 mm NC
 L2 = 85 mm NO
 Connection group: 3
 (see table "max. Switching point/Connection code")

VA Version Order Code

Type:

UNS2000

Material of Stem and Mounting Element:

VA = stainless steel 1.4571 (316 Ti)

Mounting Element (other on request)

- 3/8 - G3/8" mounting thread for inside mounting: only with PG
- T1 - G1" Tank screw (only with BN30 float)
- T2 - G2" Tank screw (not with VA80 float)
- FL4 - Flange DIN 2527, DN 65/PN16 (not with VA80 float)
- FL5 - Flange DIN 2527, DN 80/PN16

- FL6 - Flange DIN 2527, DN 100/PN16

- FLA3 - Flange ASME B16.5, 2" 150lbs, RF (not with VA80)
- FLA5 - Flange ASME B16.5, 3" 150lbs, RF (not with VA80)
- FLA6 - Flange ASME B16.5, 4" 150lbs, RF
- T2NPT - 2"NPT-Tank screw (not with VA80 float)

Electrical Connection (see table max. Switchpoints)

- ST1 - Cube Plug DIN EN 175301-803-A (former DIN 43650), 3-pin + ground, IP65 with mating plug
- ST2 - Angle Plug DIN 43651, 6-pin + ground, IP54 with mating plug
- M12x1 - M12x1 mm plug, 4-pin, IP65 without mating plug
- KL6 - Aluminum Terminal Box, 6 Terminals, IP65
- KL12 - Aluminum Terminal Box, 9 Terminals, IP65
- PG - Cable Gland with 1 m PVC-cable, -HT with silicon cable, other length on request, IP65
- K - PVC-Cable sealed, specify length at order, IP65

(Others on request)

Float type	min.Density Medium	Material	Form	Dia-meter	max. Temp.	max. Pressure (+20 ° C)
VA44	0,84 g/cm ³	SS 1.4571 (316 Ti)	Cylinder	44 mm	150 °C	15 bar
VA52	0,78 g/cm ³	SS 1.4571 (316 Ti)	Ball	52 mm	150 °C	40 bar
VA80	0,54 g/cm ³	SS 1.4571 (316 Ti)	Ball	80 mm	150 °C	17 bar

Number of Switchpoints

- L1 = 1 Switchpoint
- L2 = 2 Switchpoint
- L3 = 3 Switchpoint
- L4 = 4 Switchpoint
- L5 = 5 Switchpoint
- L6 = 6 Switchpoint

See also "Connections Groups" in table "Max. Switchpoints"

Contact Modes

Contact Rating

Order:L1, L2, L3, L4, L5, L6

- 1 - SPST (NO) 250 V AC / DC, 3 A, 100 VA / W
- 2 - SPST (NC) 250 V AC / DC, 3 A, 100 VA / W
- 3 - SPDT (WE) 140 V AC / DC, 1 A, 60 VA / W

Basic: empty tank

Total Length: L0 = ...mm (max. 3000 mm)

Specify with your order: L1 = ...mm, L2 = ...mm, etc

UNS2000 - VA/ T2 -KL6 -VA52 -L2/ 2.1 (Example)

Options:

- U = Mounting through bottom
- HT = High Temperature Application (-40 °C...+150 °C), cable and wires in silicone
- DR = Damping Tube
- VV = Vertical Adjustment (max. 5bar)
- PT100 = Pt100-Sensor
- TPxx/2 = Temperature Switch TP, Contact Rating: 3A, 12 or 24 V DC
xx = Standard: +50 °C, +60 °C, +70 °C, +80 °C, +90 °C
/2 = NC
- Exi = ATEX Ex ia (intrinsically safe) Approval, see www.barksdale.de

Needed order information e.g.:

- L0 = 200 mm
- L1 = 145 mm NC
- L2 = 60 mm NO
- Connection group: 3
(see table "max. Switching point/Connection code")

In co-operation with our customers new products can be designed. Please see some examples:



Single switch side mounted

with special tank connection and M12x1 mm connection



UNS1000

with low density float
($\min = 0.4\text{g/cm}^3$)



UNS-90-VA

Level Switch made of Stainless Steel with G3/8 mounting thread and angled 90° for side mounting



UNS-PTFE

Level switch made of PTFE for process industry (resistance)



Single switch

Level adjustment over the thread



Single Switch with damping tube (DR)

Damping oscillation fluids and float movements



UNS1000 / 2000
with cooling stem for
refrigeration and steam
plants



Single switch
complete made of plastic



**UNS1000 with
damping tube (DR)**
Damping oscillation fluid
and float movements



UNS1000-G
Level switch with float
chamber (Bypass)



**UNS2000 with
contact rod**
for grease level measurement



UNS2000-S-TF
Level switch with test
function during the operating
process

Experts

Specialists for monitoring
and control of

- ▶ Pressure
- ▶ Temperature
- ▶ Level
- ▶ Flow

Barksdale develops market-focused solutions for customers in the fluid power, transportation and industrial equipment markets focusing on applications that include:

Sensors & Switches for
Wind Turbines



Shipbuilding



Oil and gas exploration

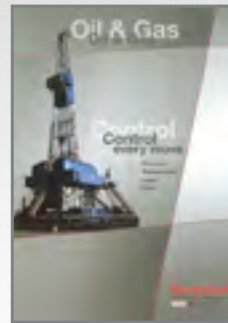

Truck, trailer and bus
suspensions



Sensors for Hydraulic
Power Packs



Product overview



Visit our website



Barksdale GmbH
(Production Center)
Dorn-Assenheimer Str. 27
61203 Reichelsheim
Germany
Phone: +49 (0) 6035 949 - 0
Fax: +49 (0) 6035 949 - 111
info@barksdale.de
www.barksdale.de

Barksdale China
(Sales Center)
33F Huaihai Plaza
1045 Central Huaihai Road
200031 Shanghai
China
Phone: +86 2161 273 000
Fax: +86 2164 733 298
chinasales@barksdale.com
www.barksdalechina.com

Barksdale Inc.
(Production Center)
3211 Fruitland Avenue
Los Angeles, CA 90058-0843
USA
Phone: +1 (323) 589 - 6181
Fax: +1 (323) 589 - 3463
sales@barksdale.com
www.barksdale.com

Barksdale Control Products
(Sales Center)
Solitaire, 6th Floor, S. No. 131/1+2,
ITI Road
Aundh, Pune - 411007
India
Phone: +91 20 30567860
Fax: +91 20 30567812
sales@barksdale.in
www.barksdale.in

Barksdale®
CONTROL PRODUCTS
CRANE Barksdale, Inc./Barksdale GmbH
A Subsidiary of Crane Co.