

SECTION B - B

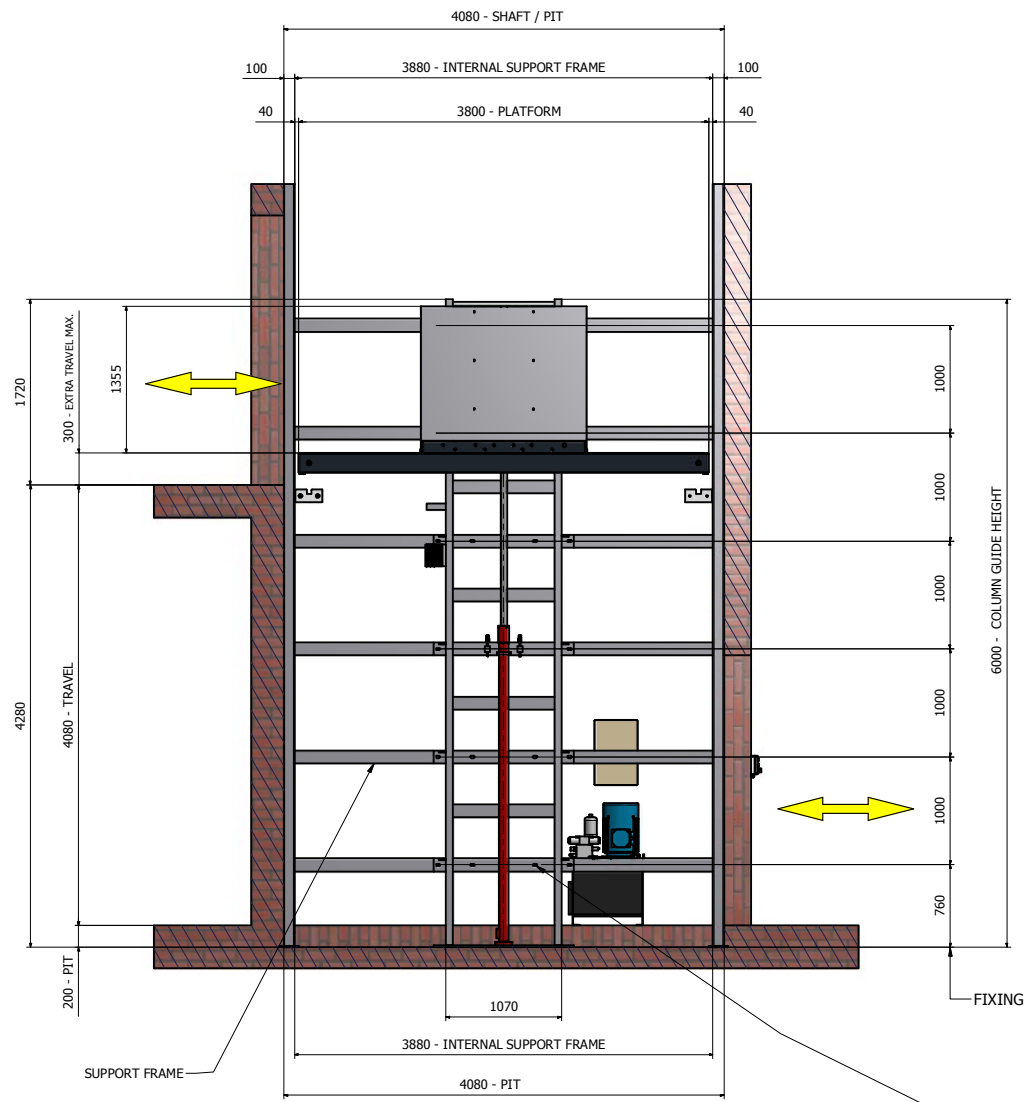

SECTION C - C

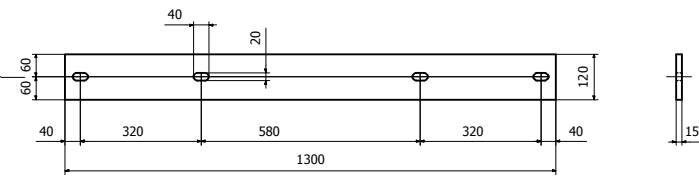
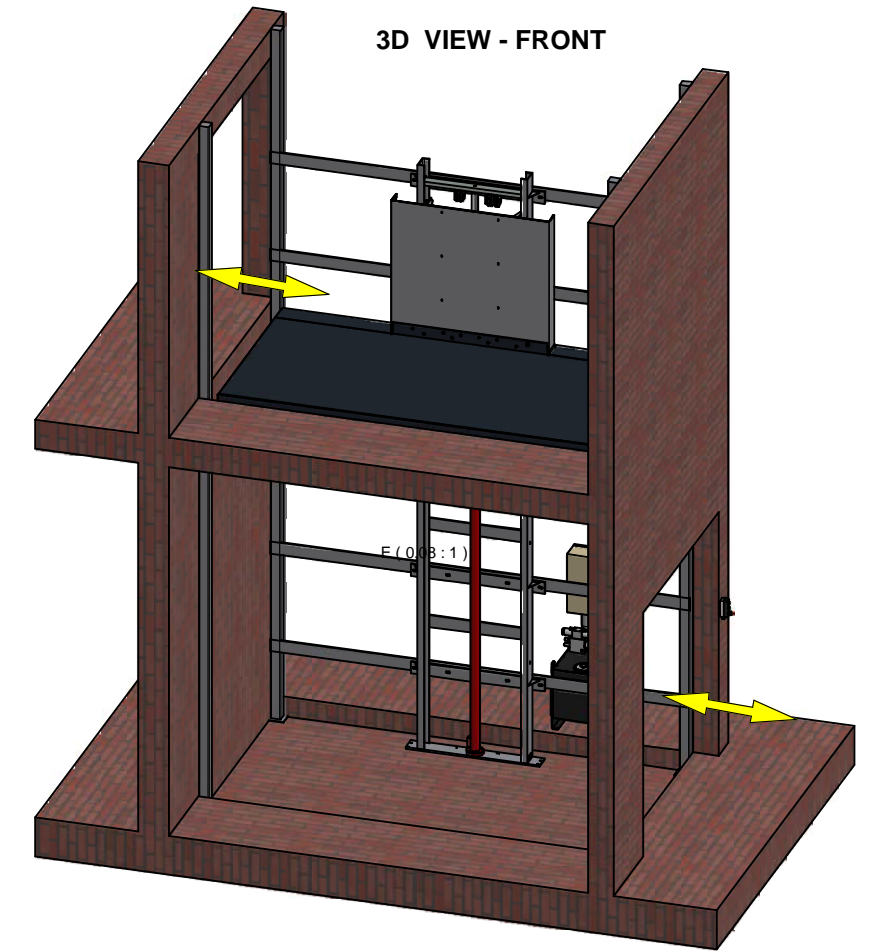
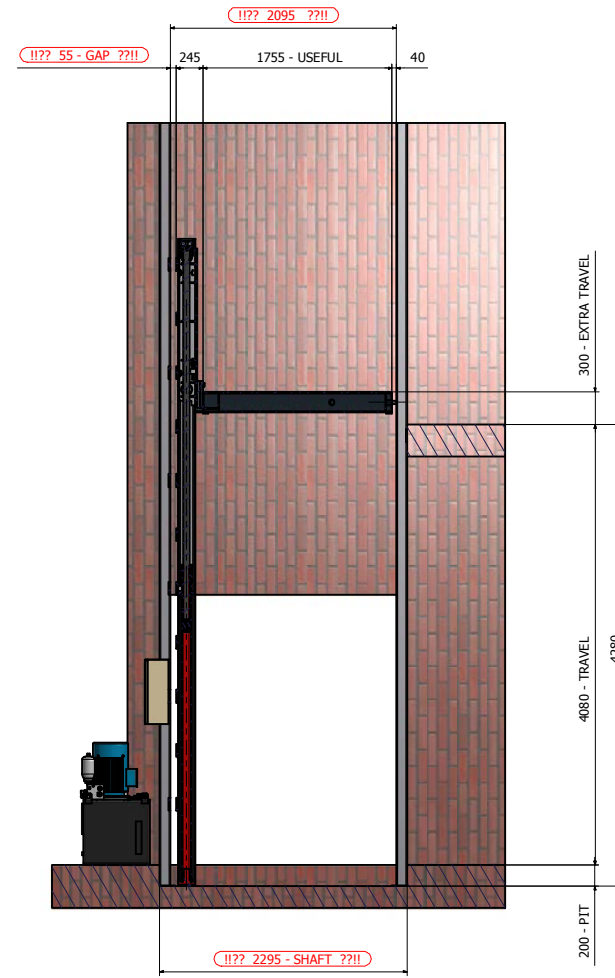

3D VIEW - BACK

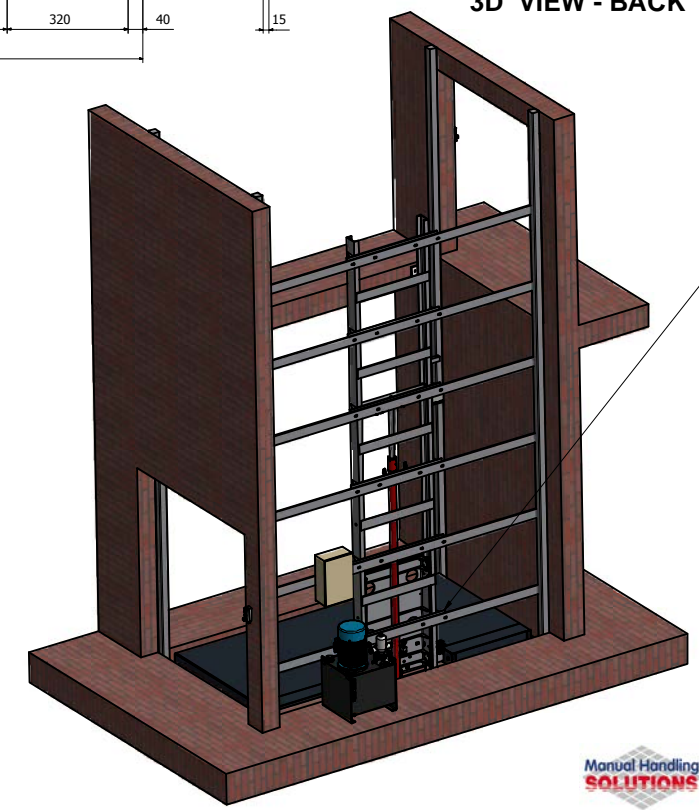
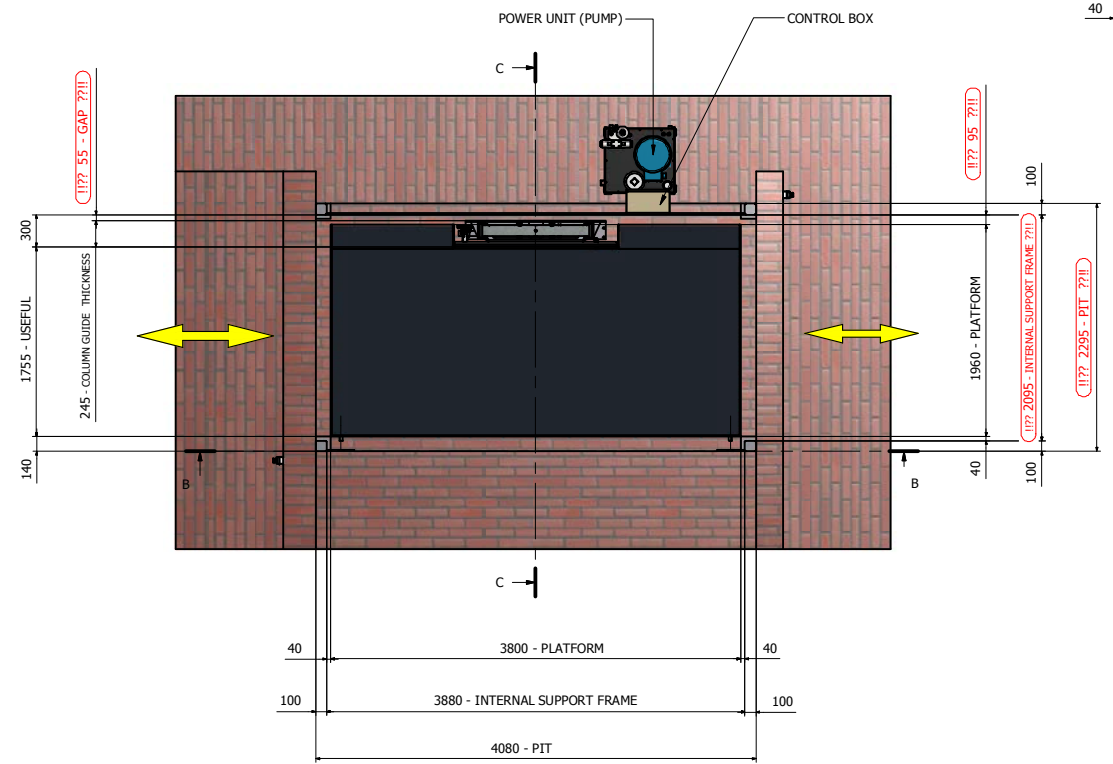
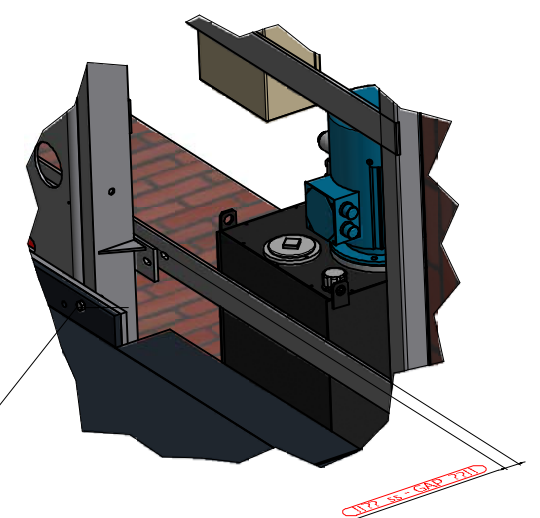

TOUCHWOOD DEVON
C - 1445
 CAPACITY = 1000 Kg
 SPEED = 6 cm/sec
 POWER = 3 Kw - 380 V.
 FINISH: PAINTED GREY RAL 9006 - RAL 7016

Manual Handling Solutions, 58, Paige Close, Watlington, Kings Lynn, Norfolk PE33 0TQ		Trattamento		A1	08/10/2014	GS	MM
Codice		Tel 01553811977		Scala	Formato	Data	Disegnatore
Descrizione		TOUCHWOOD DEVON		Commissa	C-1445		
Dimensioni		GRUPPO ASSEMBLATO		Quantita	Peso tot. N/A		
				Materiale	Disegno U1445-WS-A01		

