

IF IN DOUBT ASK

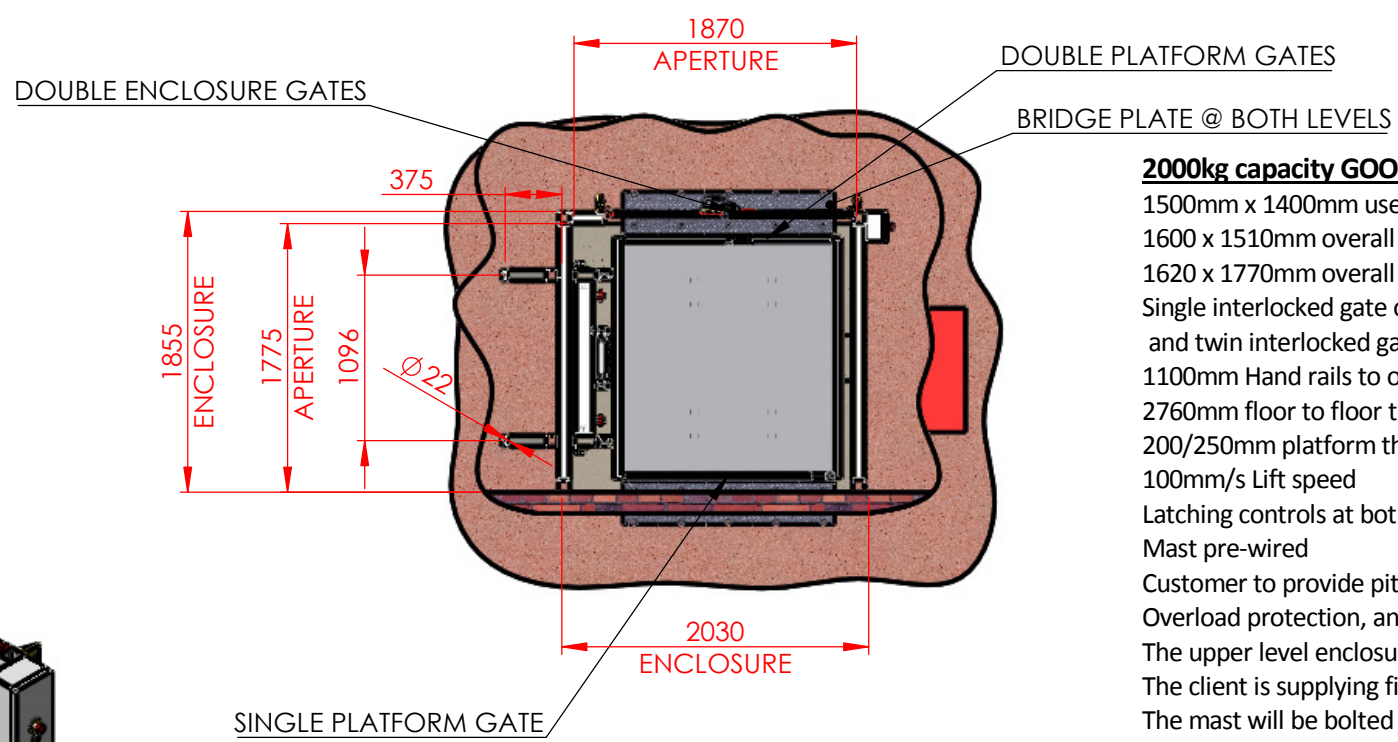

**2000kg capacity GOODS ONLY HLP1**  
 1500mm x 1400mm useable platform area,  
 1600 x 1510mm overall platform area,  
 1620 x 1770mm overall footprint (including mast)  
 Single interlocked gate on one 1510mm side (adjacent to mast – lower level access)  
 and twin interlocked gate opposite (other 1510mm side – upper level access)  
 1100mm Hand rails to other two sides (mast side and opposite mast)  
 2760mm floor to floor travel (the lift will be pit mounted –  
 200/250mm platform thickness/pit depth)  
 100mm/s Lift speed  
 Latching controls at both levels  
 Mast pre-wired  
 Customer to provide pit with trench under for routing of hoses  
 Overload protection, anti-slip surface, maintenance stops & manual emergency lowering  
 The upper level enclosure is 1600mm high with twin gates  
 The client is supplying fire doors at the lower level for which AH will supply interlocks  
 The mast will be bolted to the wall in the lift shaft

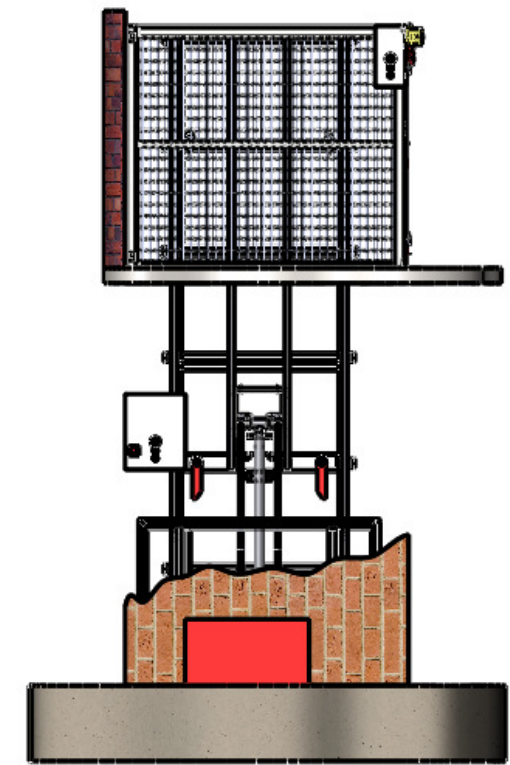
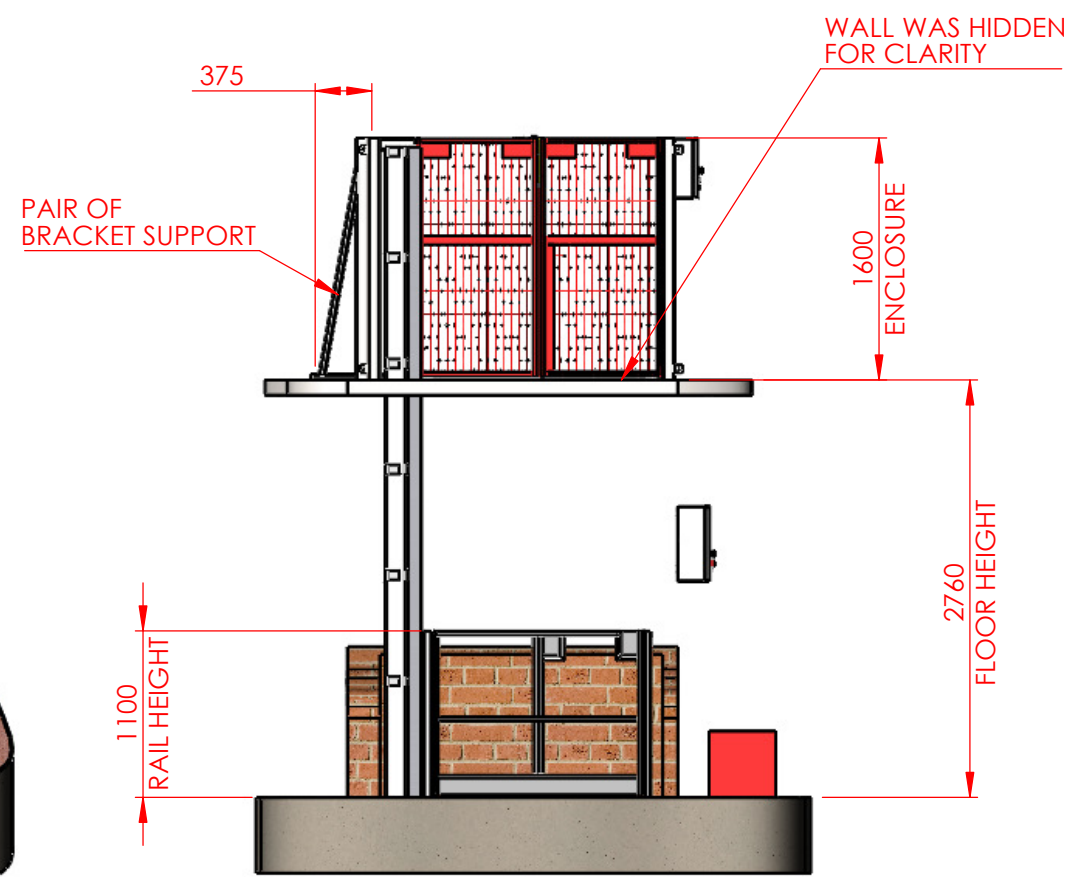
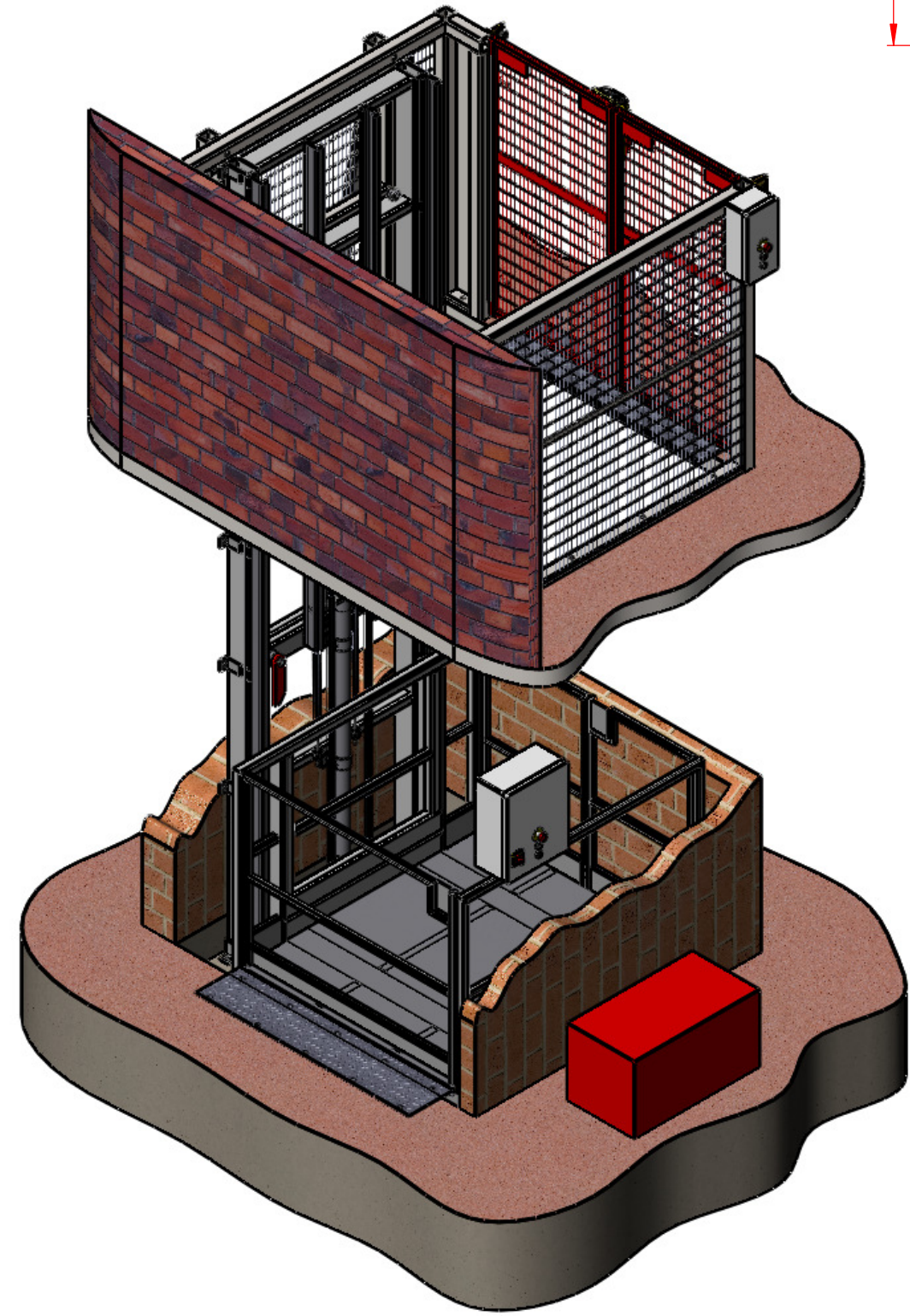

THIRD ANGLE PROJECTION UNLESS OTHERWISE SPECIFIED (ALL DIMENSION IN mm) <b>DIMENSION TOLERANCES</b> LINEAR - ±0.5mm HOLES - ±0.1mm ANGLES - ±1° RAD/CHAM - ±0.5mm REMOVE ALL BURRS AND SHARP EDGES	PART No: SP-MZL-2000-38379B PART NAME: 2000kg capacity GOODS ONLY HLP1		No. OFF. 1
	MATERIAL: -	WEIGHT: - kg.	DRAWN: O.TESU
	FINISH: SEE NOTE	DRAWN: 18/1/2015	SHEET: 1 OF 2
	DRAWING. No: D-SP-MZL-2000-38379B-Presentation-B	SHEET SCALE 1:50	DO NOT SCALE
		SHEET SIZE: <b>A3</b>	

B	SUPPORT BRACKET'S ADDED	18/01/2015
REV.	DESCRIPTION	DATE

IF IN DOUBT ASK

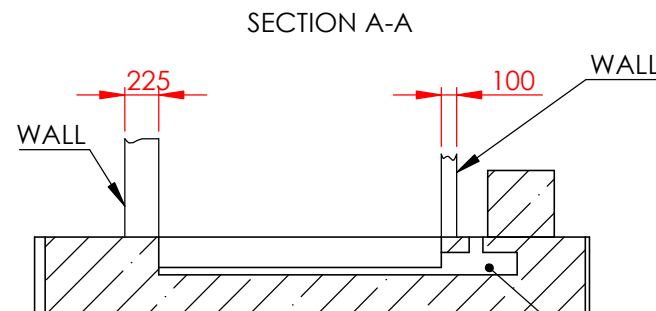
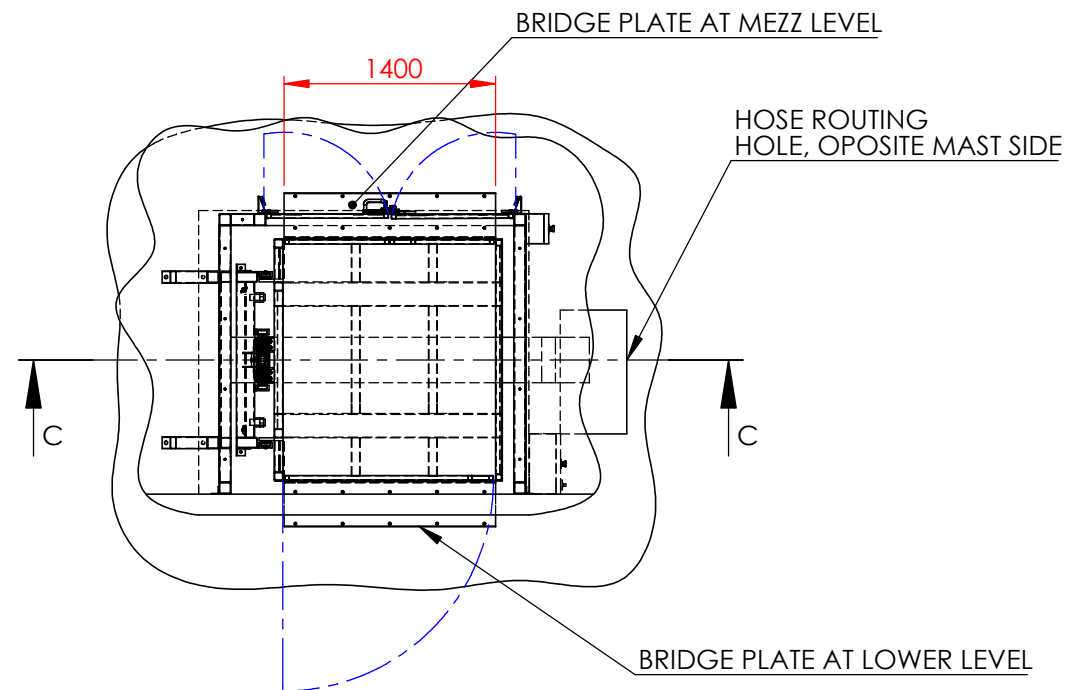

Trench for services – location & dimensions to be confirmed

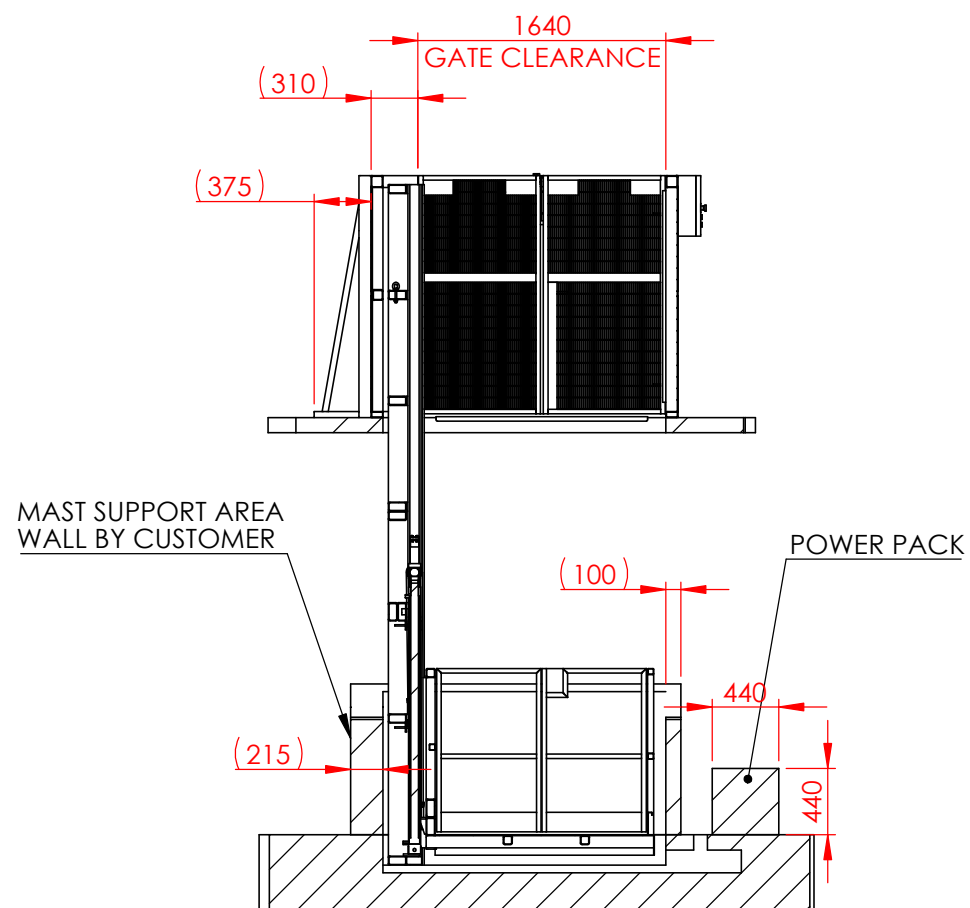
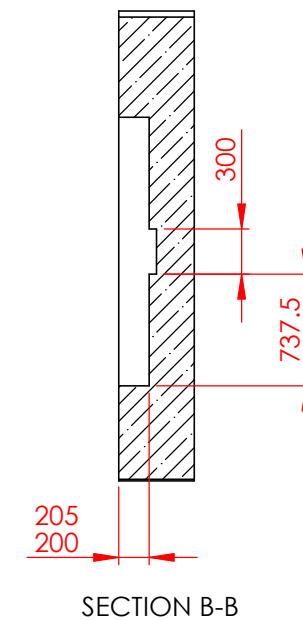
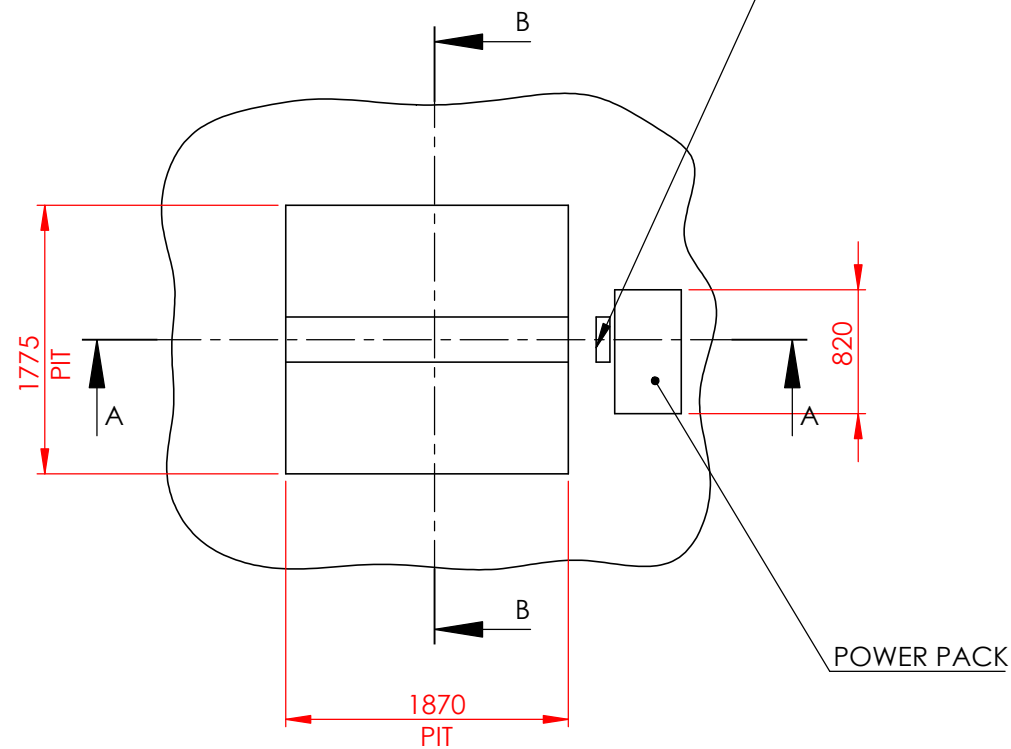

SECTION C-C

THIRD ANGLE PROJECTION

UNLESS OTHERWISE SPECIFIED (ALL DIMENSION IN mm)

**DIMENSION TOLERANCES**

LINEAR - ±0.5mm  
HOLES - ±0.1mm  
ANGLES - ±1°  
RAD/CHAM - ±0.5mm

REMOVE ALL BURRS AND SHARP EDGES

PART No: SP-MZL-2000-38379B  
PART NAME: 2000kg capacity GOODS ONLY HLP1

No. OFF.  
1

MATERIAL: - WEIGHT: - kg. DRAWN: O.TESU

FINISH: SEE NOTE DRAWN: 18/1/2015 SHEET: 2 OF 2

DRAWING. No: D-SP-MZL-2000-38379B-Presentation-B SHEET SCALE 1:50 DO NOT SCALE

SHEET SIZE: **A3**



REV.	DESCRIPTION	DATE
B	SUPPORT BRACKET'S ADDED	18/01/2015