

SECTION A - A

SECTION B - B

3D VIEW

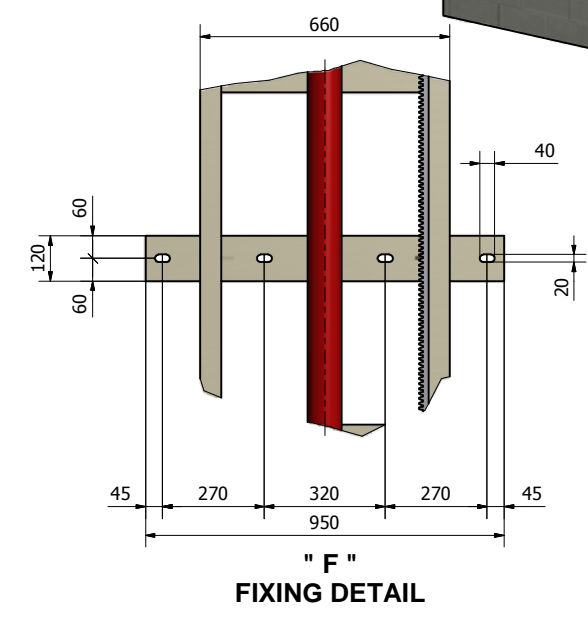
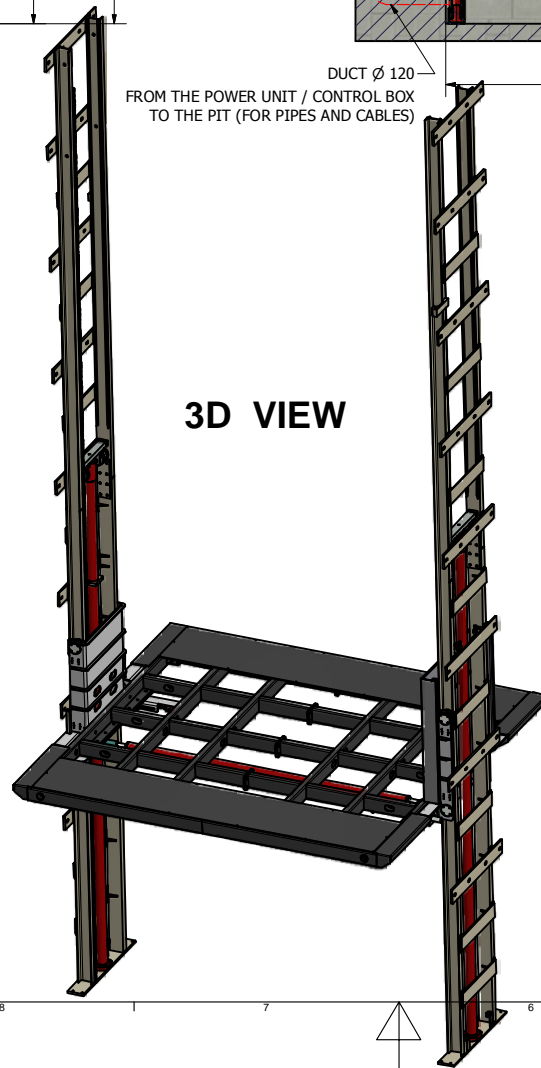
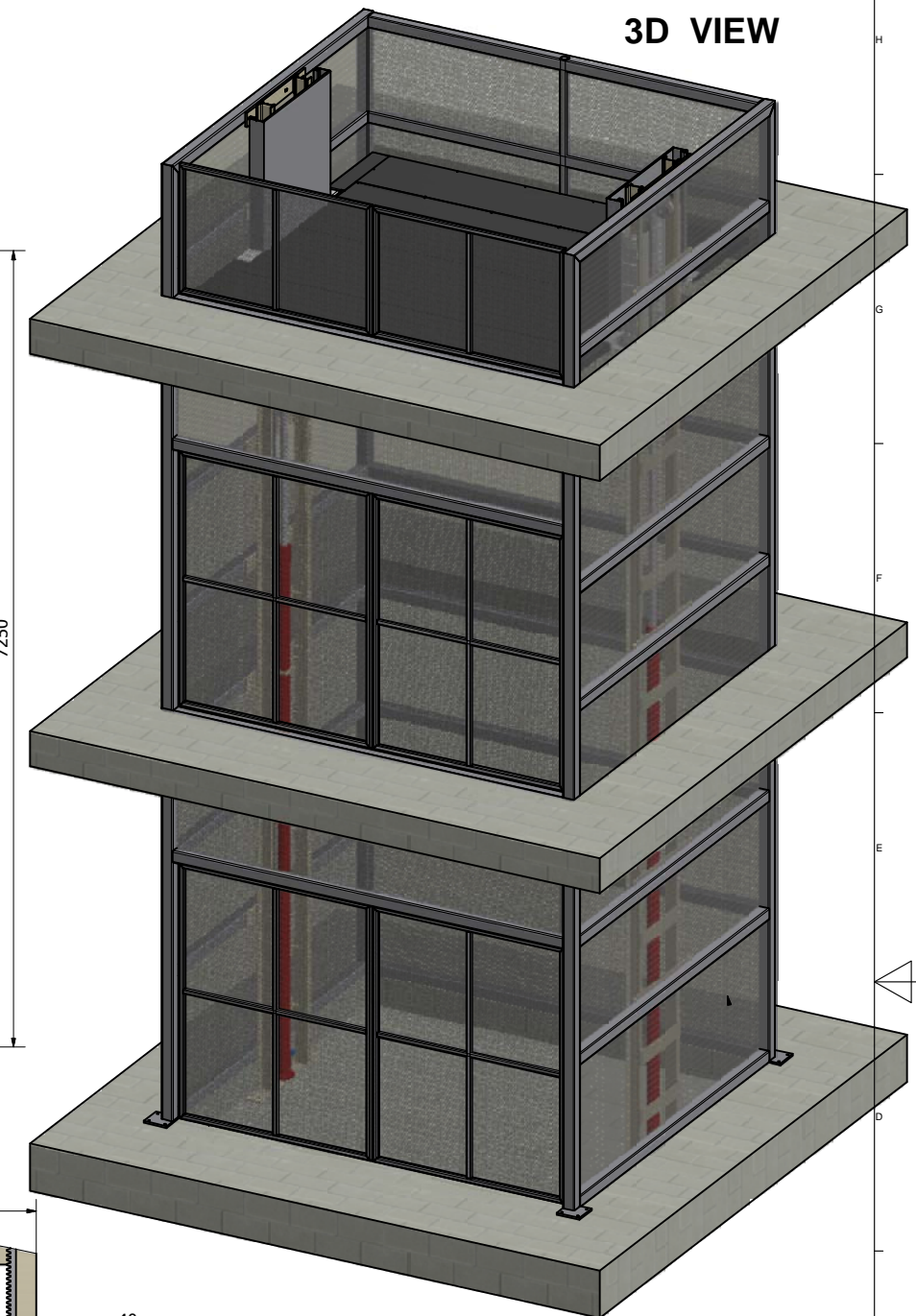
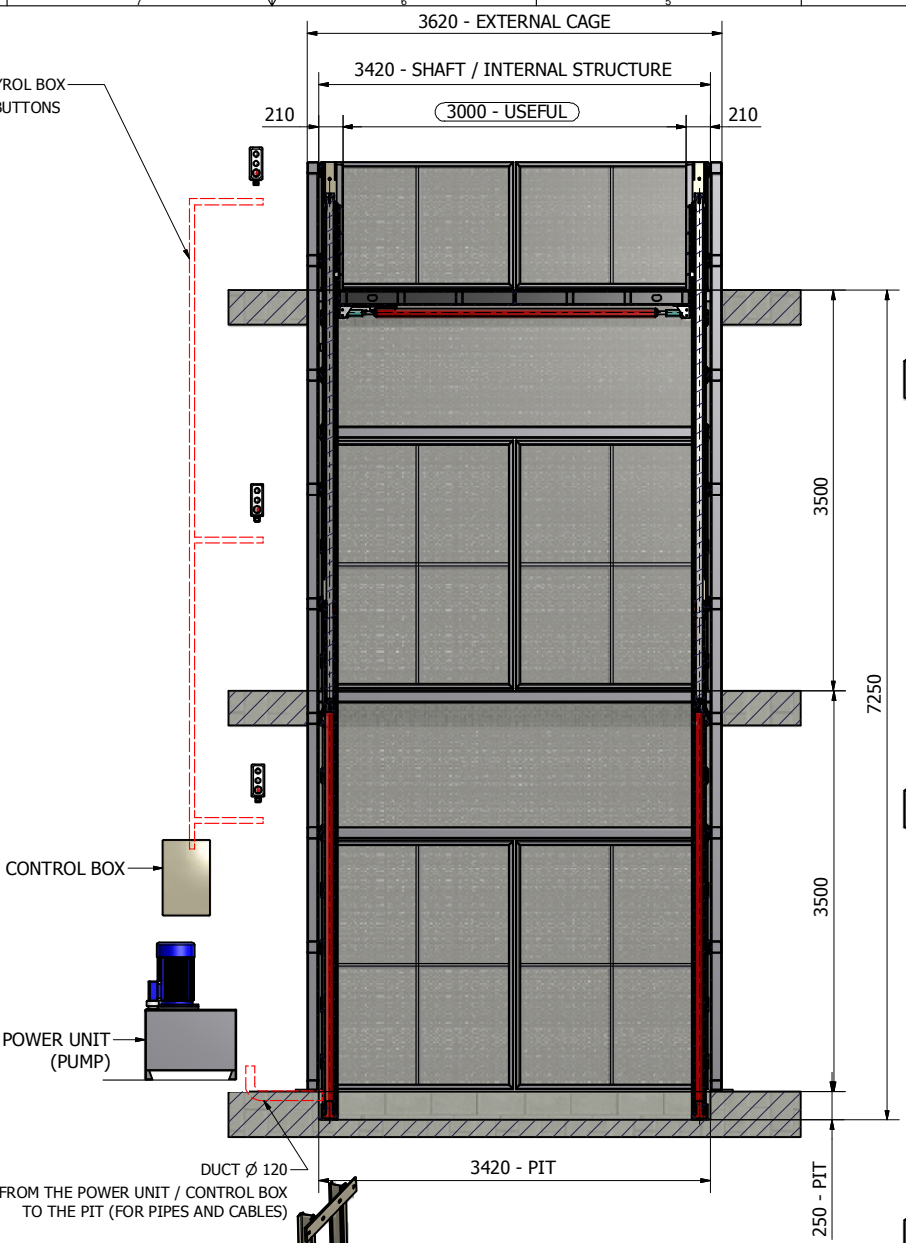
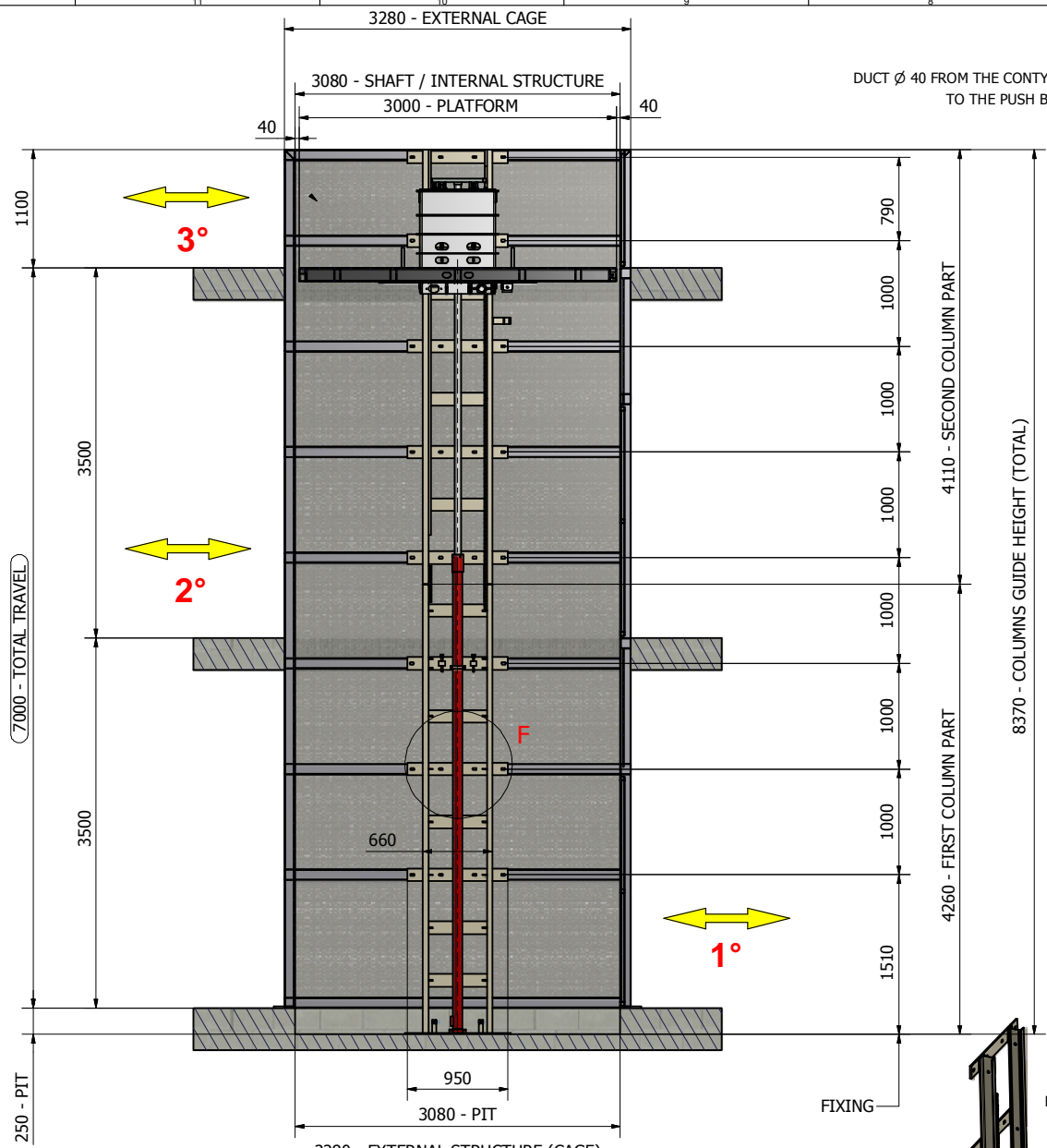

CAPACITY = 1500 Kg
 SPEED = 10 cm/sec
 POWER = 5.5 Kw - 380 Volt
 NOMINAL CURRENT = 12.5 Amp.
 CUE CURRENT = 87.5 Amp.
 FINISH: PAINTED GREY - RAL 9006 - RAL 7016
 RED - RAL 3001 (CYLINDERS)

TOP VIEW

PRELIMINARY DRAWING REV. "4" 30-03-2016