

SECTION A - A

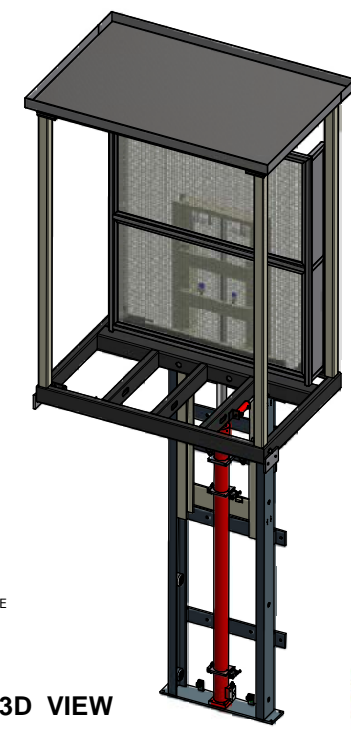
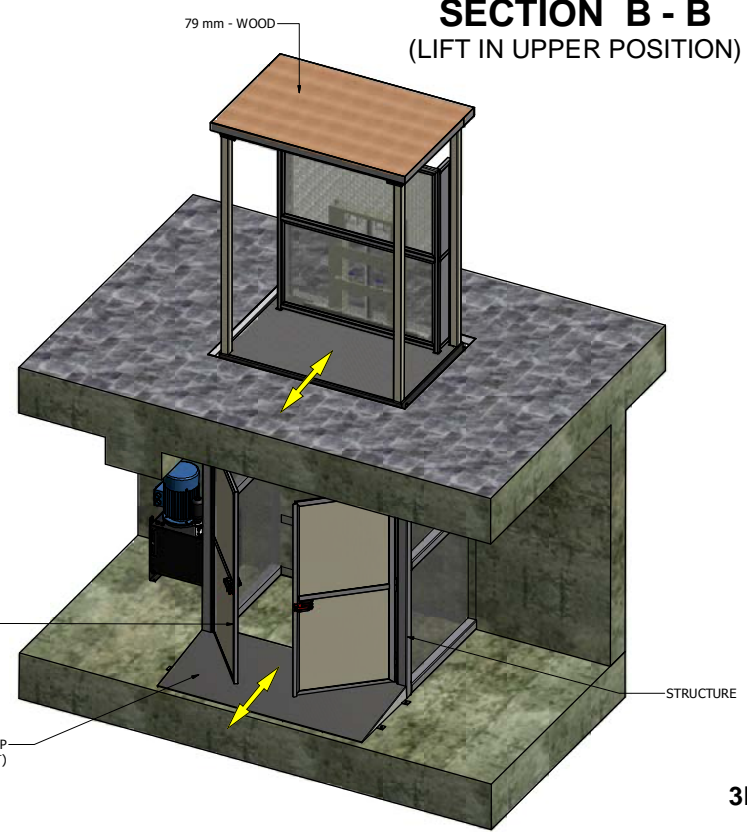
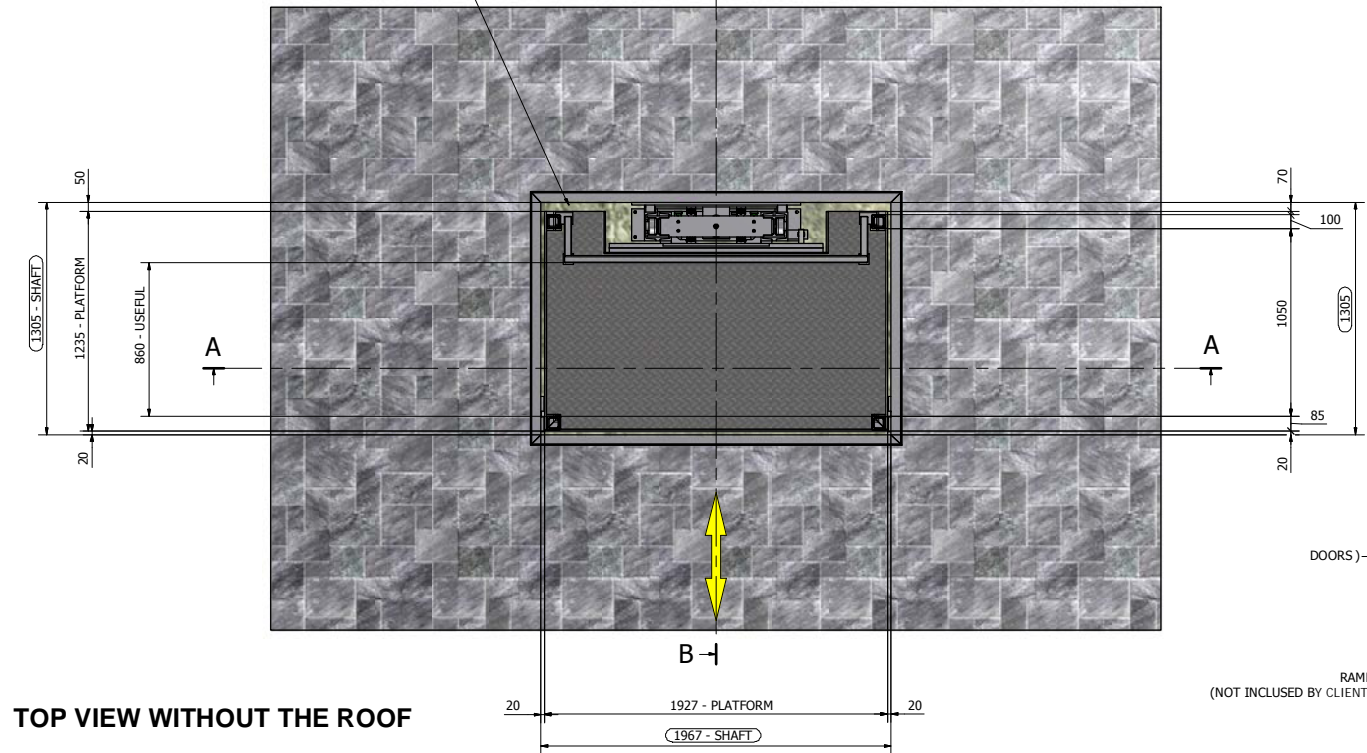
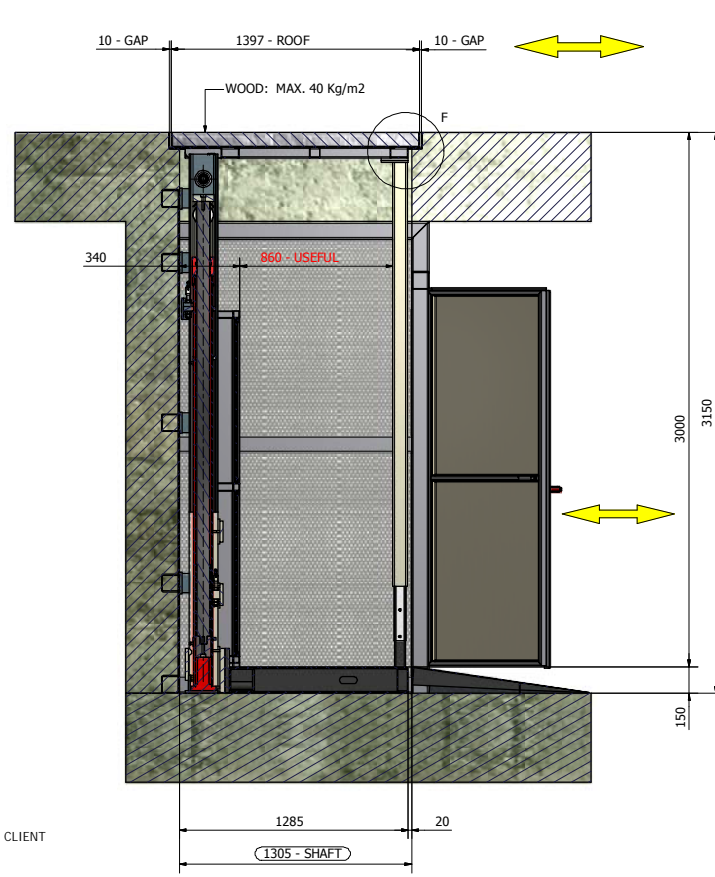
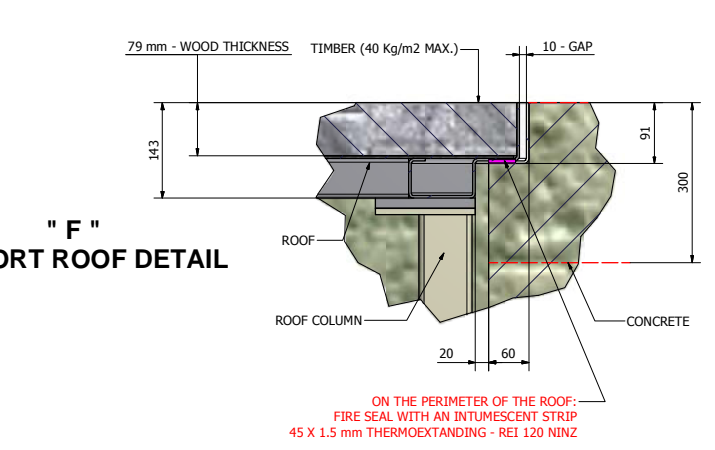
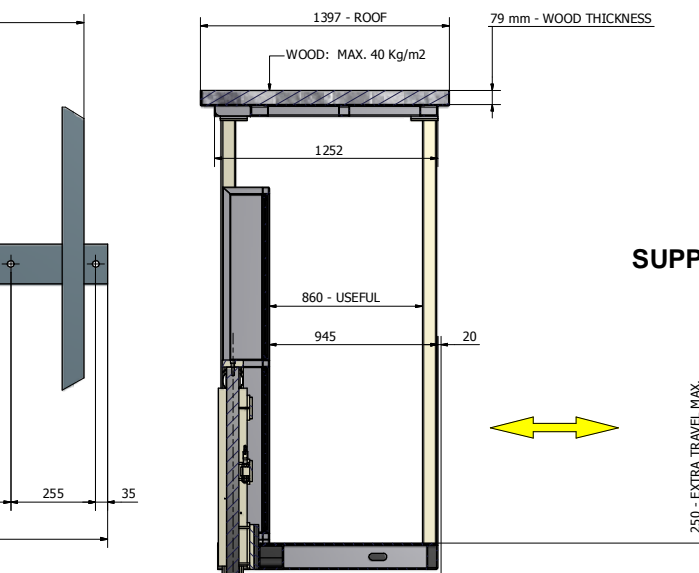
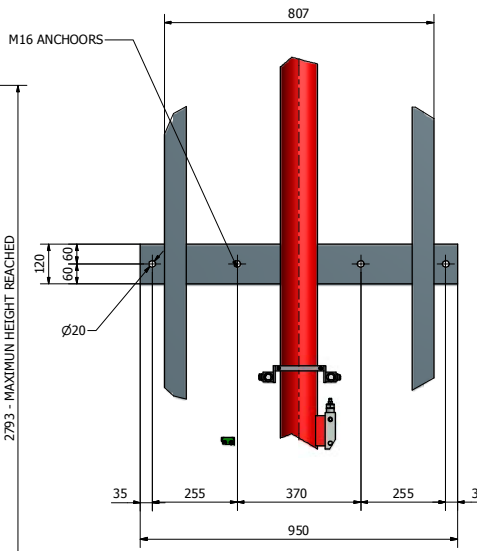
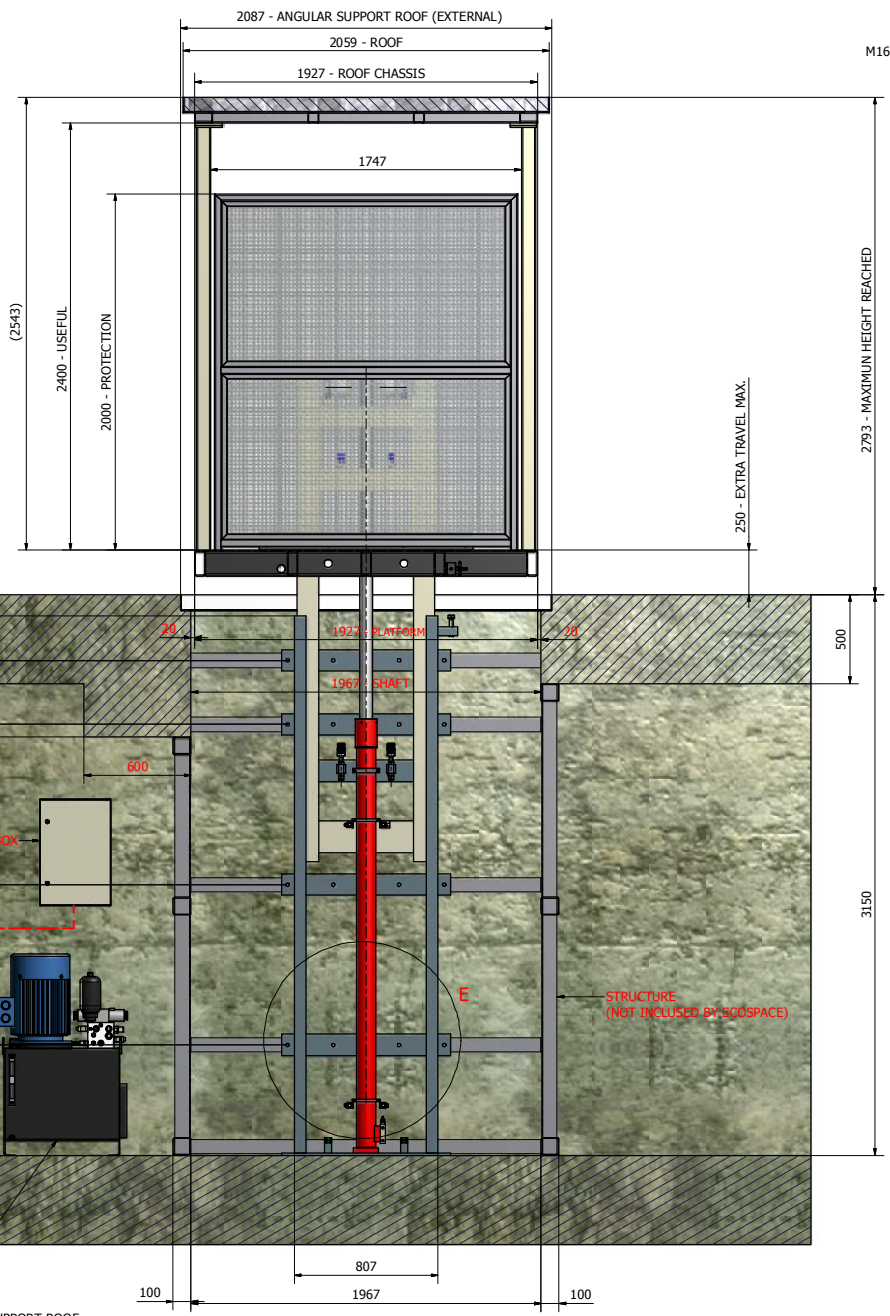

3D VIEW

SECTION B - B (LIFT IN LOWER POSITION)

KIMMERIGE FOSSIL MUSEUM

C - 1255
 CAPACITY = 1000 Kg
 SPEED = 5 cm/sec
 POWER UNIT = 3 Kw - 400 Volt
 NOMINAL CURRENT = 7 Amp.
 CUE CURRENT = 42 Amp.
 FINISH: PAINTED GREY RAL 9006 - RAL 7016
 RED RAL 3001 (CYLINDERS)

REV. "6" - 17-10-2016

Manual Handling SOLUTIONS
 Manual Handling Solutions
 58 Paige Close, Watlington
 Kings Lynn, Norfolk PE33 0TQ
 Tel 01553811977
 sales@manualhandlingsolutions.co.uk