

Section A-A

Section B-B

Attention !!!

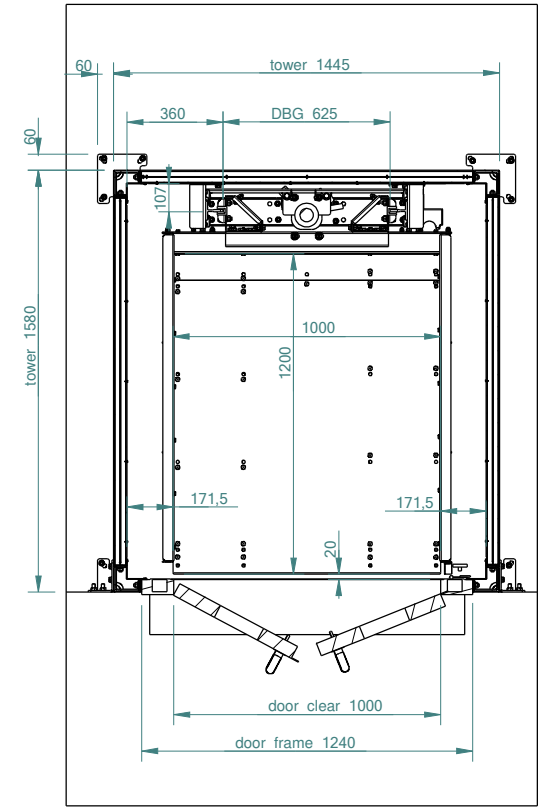
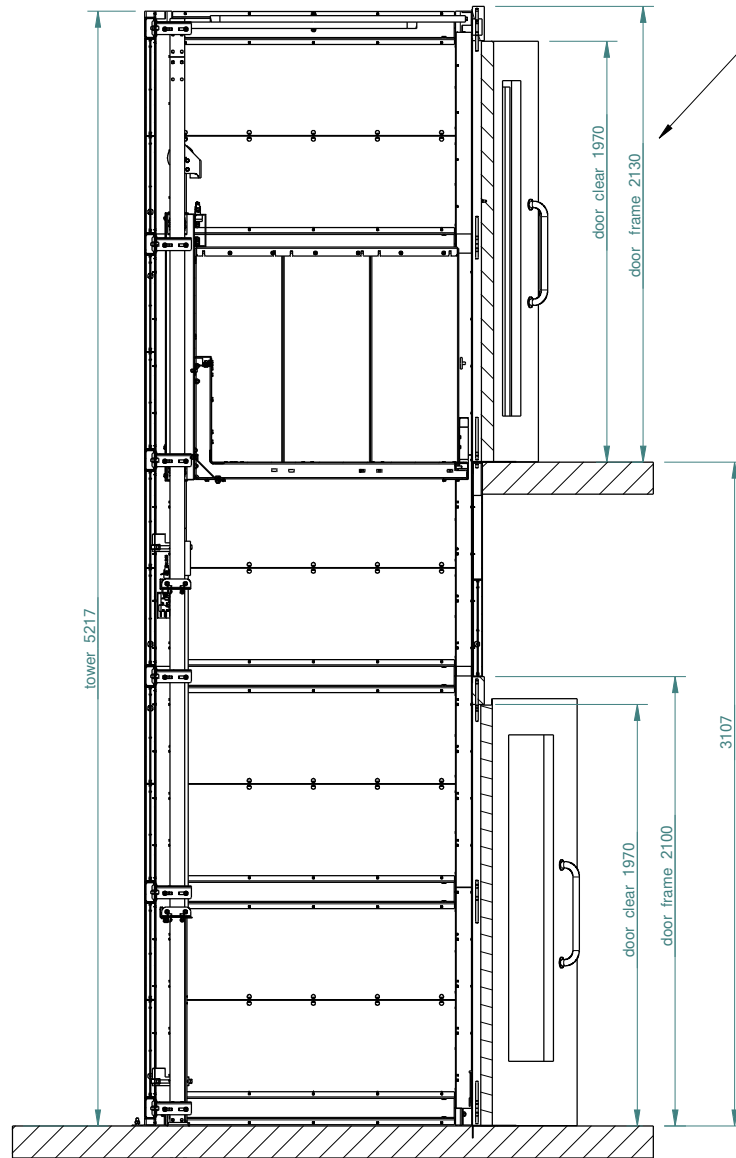
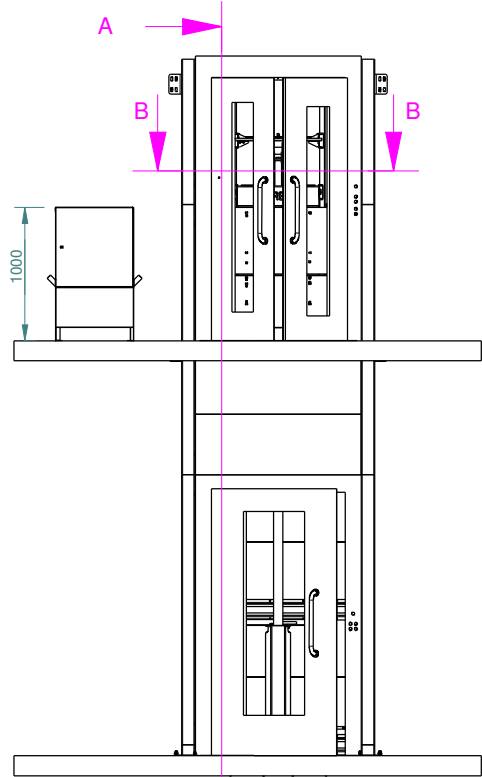

Speed 0.13 m/s
Tower color RAL 7024
Platform color Cav RED

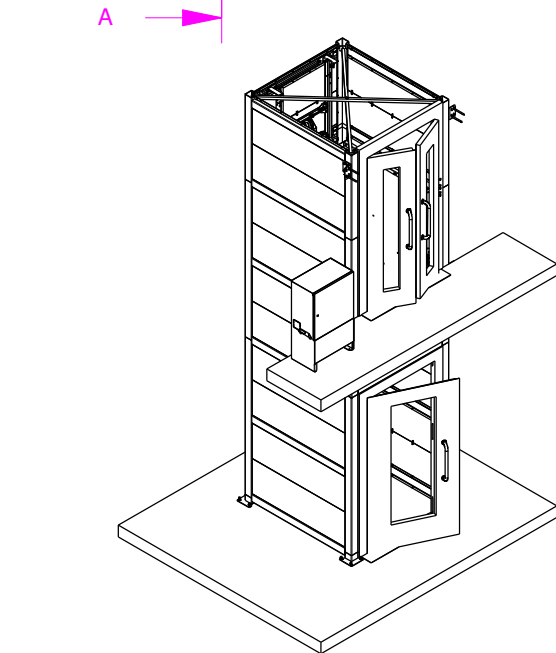

Itemref	Quantity	Title/Name, designation, material, dimension etc	Article No./Reference		
Drawn by	Checked by	Approved by - date	File name	Date	Scale
Manual Handling Solutions 58 Paige Close, Watlington Kings Lynn, Norfolk PE33 0TQ Tel 01553811977 sales@manualhandlingsolutions.co.uk		500kg Goods only lift with Press to Go controls		Edition	Sheet
		Pigney - Cumbria			