

1

2

3

4

5

6

RevNo	Revision note	Date	Signature	Checked
-------	---------------	------	-----------	---------

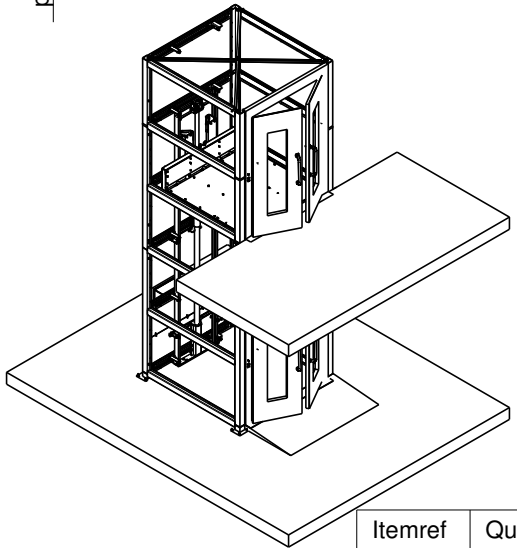
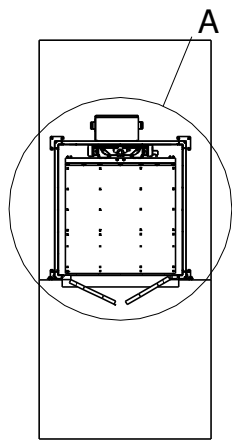
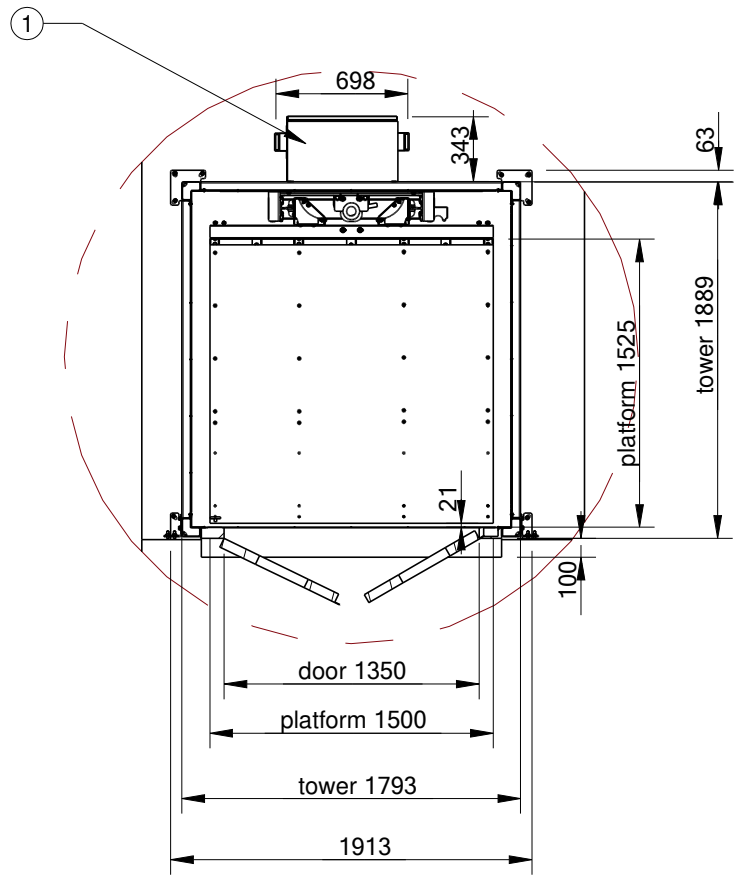
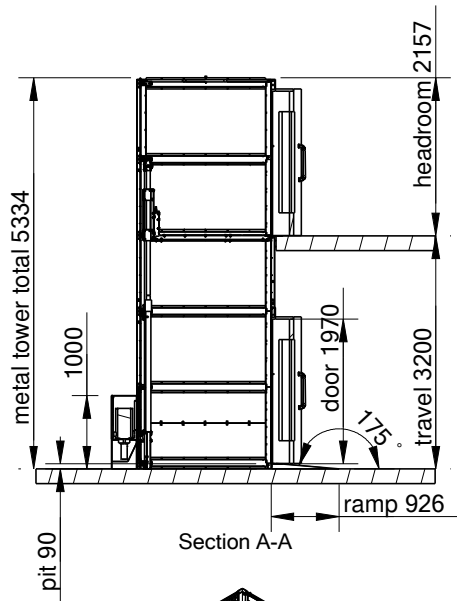
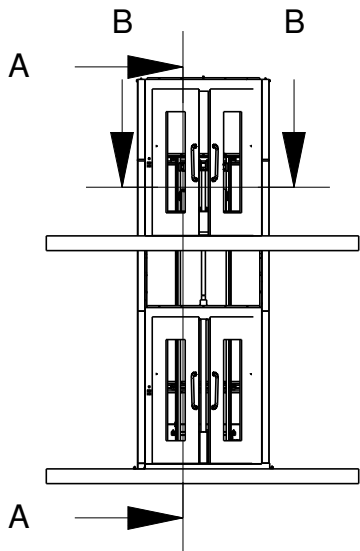

- 1) Power supply 3x400 VAC, 16 A
- 2) Indoor installation

Goods only lift 500
 Load 500 kg,
 Speed 0.13 m/s
 Tower color RAL7024
 Platform color Cav RED

Itemref	Quantity	Title/Name, designation, material, dimension etc			Article No./Reference	
Drawn by Martin Hancock		Checked by	Approved by - date	File name	Date 26.07.2016	Scale
		Manual Handling Solutions 58, Paige Close, Watlington Kings Lynn, Norfolk PE33 0TQ Tel 01553 811977 sales@manualhandlingsolutions.co.uk			Press to Go controls	
					166 Bender Ulverston Cumbria	

Signed as correct
 Name..... Date.....
 Signed.....

1

2

3

6