

Section A-A

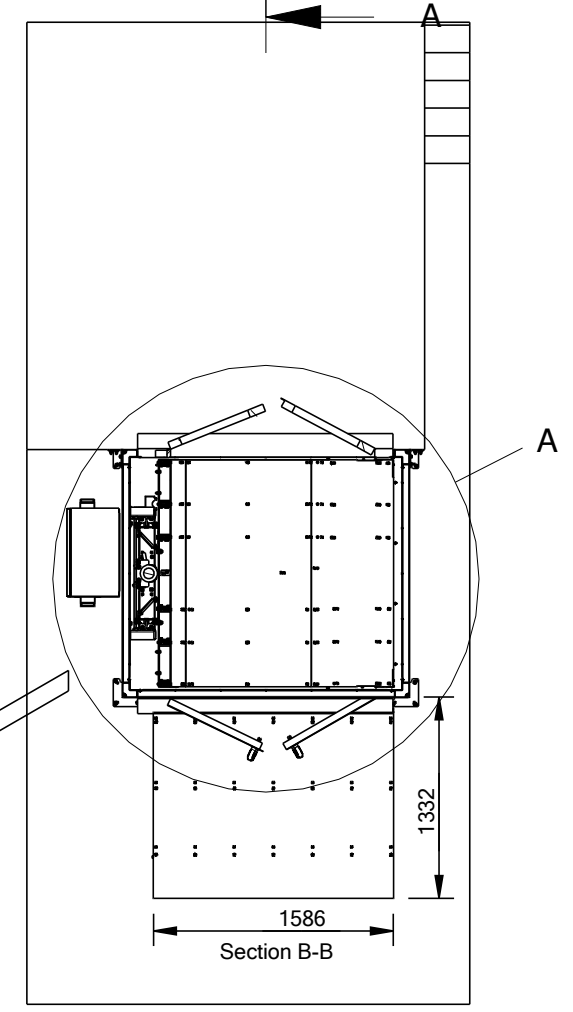
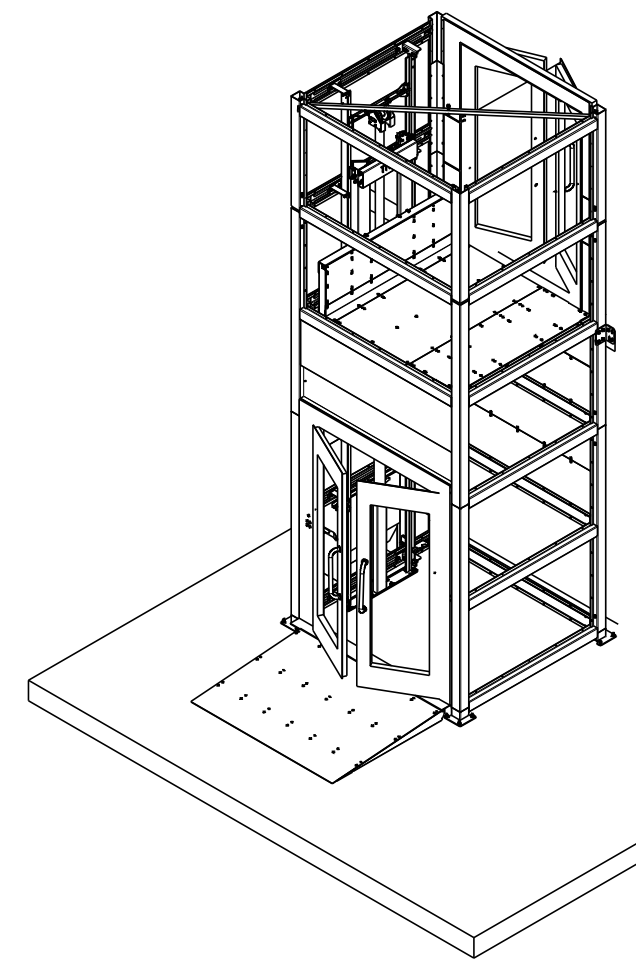

Detail A

Goods only lift 1500
 Load 1500 kg
 Speed 0.13 m/s
 Tower collar RAL 7024
 Platform color Cav RED

Itemref	Quantity	Title/Name, designation, material, dimension etc	Article No./Reference		
Drawn by Martin Hancock	Checked by	Approved by - date	File name	Date 29.11.2016	Scale
Manual Handling Solutions 58 Paige Close, Watlington Kings Lynn, Norfolk PE33 0TQ Tel 01553811977 sales@manualhandlingsolutions.co.uk			Fitted with "press to Go" controls		
			Edition	Sheet	