

Furniture & Architectural  
Hardware  
**SUGATSUNE**

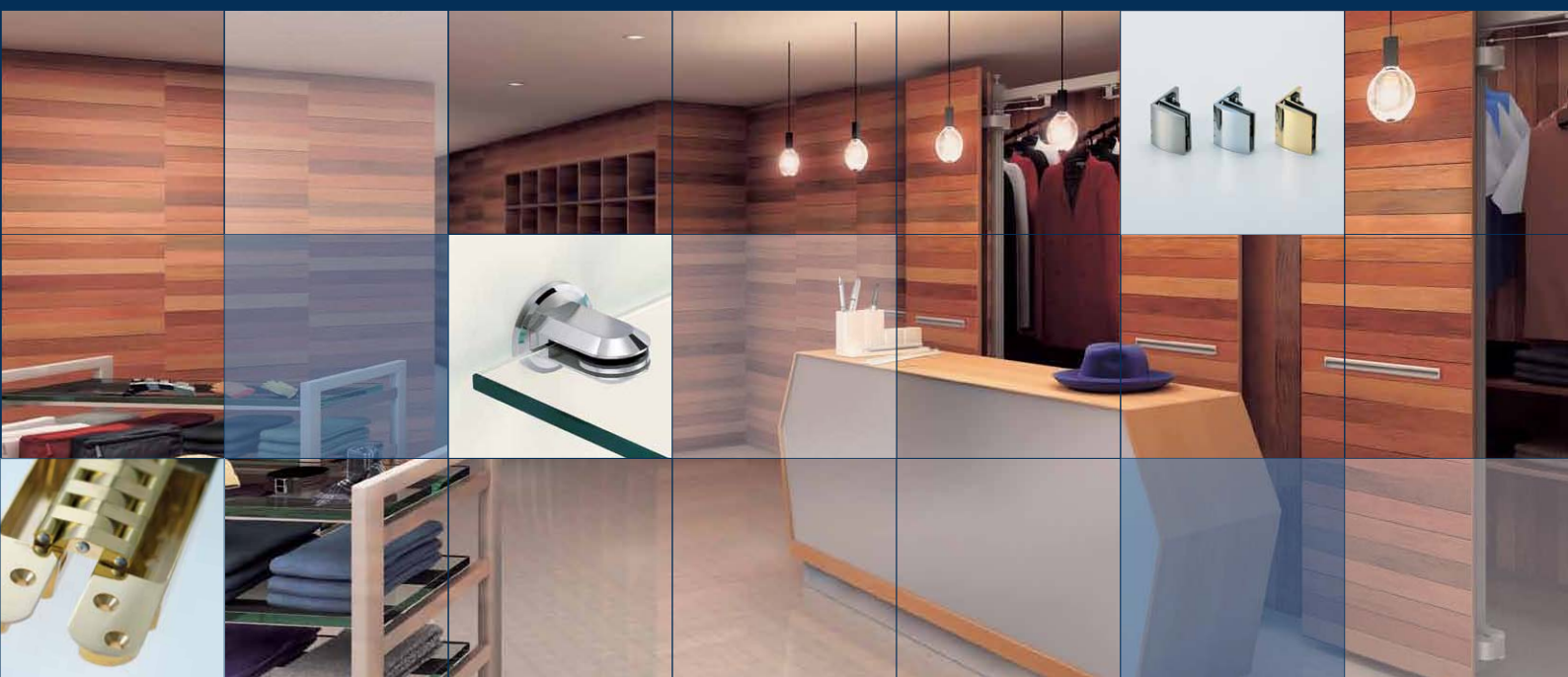

■ ■  
**SUGATSUNE**  
■ ■

**No.203**

Sugatsune - A hardware manufacturer with worldwide reputation for high quality products that combines ingenious design with meticulous attention to detail.

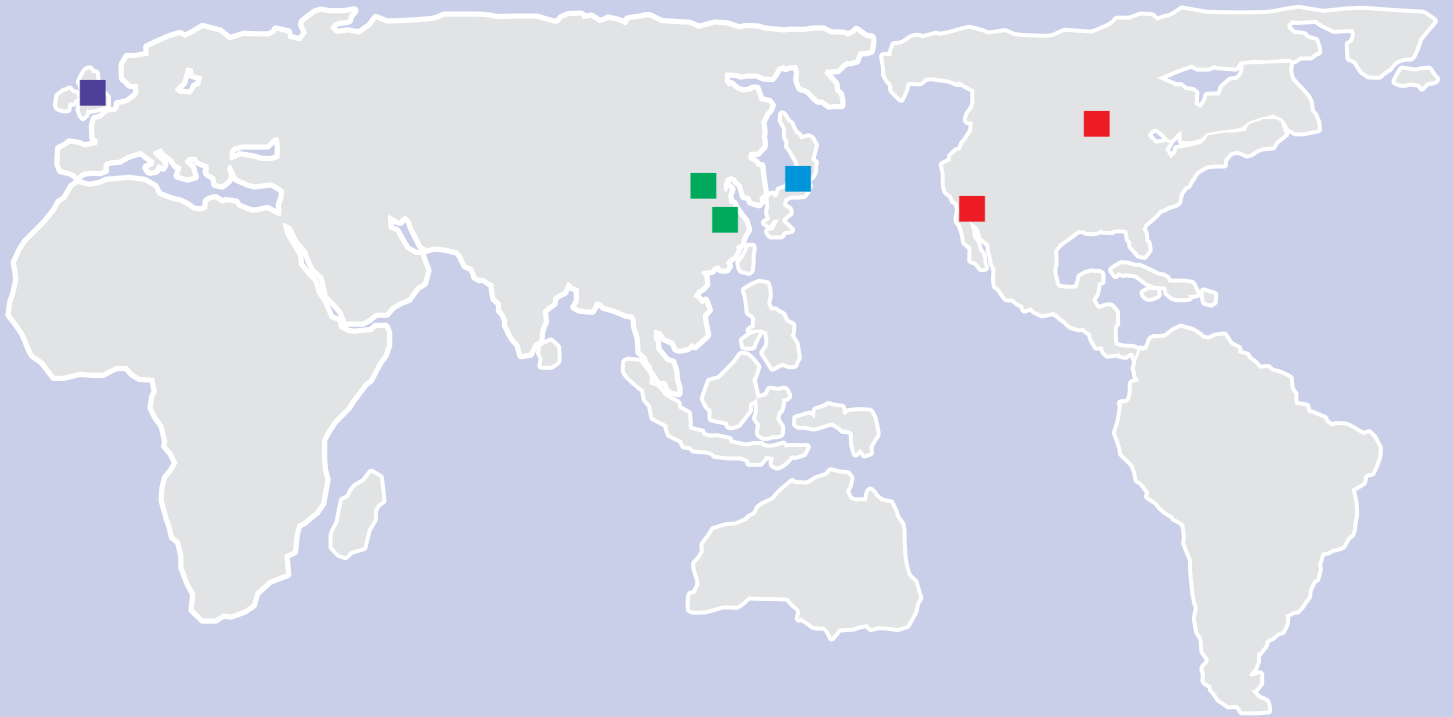

UK Office



TOKYO Showroom

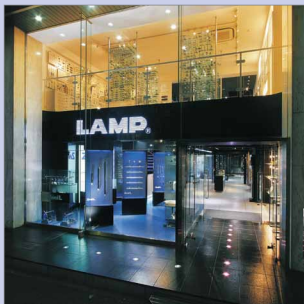

Global Headquarters



Chicago Office



Beijing Office



Shanghai Office



Los Angeles Office





**Zwei L**<sup>®</sup>



**LAMP**<sup>®</sup>



**Lapcon**

### **SOLUTIONS FROM AN INDUSTRY LEADER**

SUGATSUNE continues to be a leading source for unique, high-quality hardware products. Architects, builders, designers and OEM's continue to depend on our SUGATSUNE quality and craftsmanship. You'll see and feel the Lapcon difference in every product, from catches and latches to our patented dampening mechanisms.

Manufacturing the finest quality hardware is our mission. With design offices in Japan and distributorships in the U.S.A. , U.K., China, and around the world, we offer prompt delivery to meet your deadlines and schedules.

### **THE SUGATSUNE DIFFERENCE**

#### **Precision Quality** - Guaranteed

Our products are designed to meet your exacting standards. SUGATSUNE quality craftsmanship ensures years of trouble-free operation.

#### **Vast Selection** - Guaranteed

Choose from more than 20,000 items, all manufactured by SUGATSUNE or produced exclusively for us. Each product is created to meet your every need in the global marketplace with extensive local distribution and large inventory.











#### **Customer Satisfaction** - Guaranteed

You can rely on the SUGATSUNE combination of product and availability to insure complete satisfaction. Experience our superior customer service from the moment you place your order to the time an order ships.







#### **Advanced Design** - Guaranteed

SUGATSUNE is constantly innovating advanced new hardware solutions. Our design and engineering staff stay abreast of the latest trends to bring you exemplary products.





## Architectural Solutions - Sliding &amp; Folding Door Fittings

Picture	Item Name	Page
	FD SLIDING DOOR SYSTEM-OVERVIEW	5
	FD30-H SLIDING DOOR SYSTEM	7
	FD30-H MULTIPLE SYNCHRONIZED SLIDING DOOR	9
	FD50-H SLIDING DOOR SYSTEM	11
	FD50-H MULTIPLE SYNCHRONIZED SLIDING DOOR	13
	FD80-H SLIDING DOOR SYSTEM	15
	FD80-AF ALUMINUM FRAME SLIDING DOOR	17
	LM-80/G SELF CLOSING SLIDING DOOR SYSTEM	21
	FD30-F FOLDING DOOR SYSTEM	23
	FDP40P STACKABLE PARTITION DOOR SYSTEM	27
	FDP40V STACKABLE PARTITION DOOR SYSTEM	29









## Architectural Solutions - Swing Door Fittings

Picture	Item Name	Page
	LDD-V LAPCON DOOR DAMPER (RECESSED MOUNT TYPE)	31
	LDD-S LAPCON DOOR DAMPER (SURFACE MOUNT TYPE)	32
	HES HES3D HINGE SERIES	33
	HES3D-120 3-WAY ADJUSTABLE CONCEALED HINGE	34
	HES3D-160 3-WAY ADJUSTABLE CONCEALED HINGE	35
	HES3D-E190 3-WAY ADJUSTABLE CONCEALED HINGE	36

## Wardrobe Solutions

Picture	Item Name	Page
	MFU-1000 FLUSH SLIDING DOOR SYSTEM	37
	LIN-X450 MONOFLAT LIN-X HINGE / STANDARD KIT	40
	LIN-X600 MONOFLAT LIN-X HINGE / STANDARD KIT	40
	LIN-X450 INDIVIDUAL PARTS FOR TALL / HEAVY DOOR	41
	LIN-X600 INDIVIDUAL PARTS FOR TALL / HEAVY DOOR	42
	FAD-5 MONOFLAT FAD (FOR LIGHT WEIGHT DOORS)	43
	ATL-F FOLDING POCKET DOOR SYSTEM	44

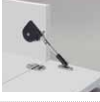
## Cabinet solutions

Picture	Item Name	Page
	SLS-ELAN EASY LIFT-UP STAY	45
	EZS-ELAN LIFT ASSIST STAY	47
	HBF-ELAN BI-FOLD LIFT ASSIST STAY	49
	SLU-ELAN SWING LIFT-UP STAY	50
	SLD SWING DOWN STAY	51
	HDS-10S SELF CLOSE STAY	52
	LAPCON OTHER LAPCON SOLUTIONS	53
	No. 182 INTRODUCTION OF CATALOGUE No. 182	54

## FD SLIDING DOOR SYSTEM - Overview



FD30-H



FD50-H



FD80-H

Type	FD30-H				FD50-H				FD80-H			
	Standard Sliding		One-Way Soft Close	Two-Way Soft Close	Standard Sliding		Two-Way Soft Close		Standard Sliding		Two-Way Soft Close	
Roller	Recessed Mount	Side Mount	Recessed Mount	Recessed Mount	Recessed Mount	Surface Mount	Recessed Mount	Surface Mount	Recessed Mount	Surface Mount	Recessed Mount	Surface Mount
Weight	Max. 30kg				Max. 50kg				Max. 80kg			
Thickness	Min. 24 mm	Min. 28mm	Min. 24mm	Min. 24mm	Min. 24 mm	Min. 30 mm	Min. 24 mm	Min. 30mm	Min. 34mm	Min. 30mm	Min. 34mm	Min. 30mm
Width	Max. 1000m	Max. 1000mm	510 to 1000mm	590 to 1000mm	Max. 1500m		680 to 1500mm		Max. 1500m		784 to 1500mm	
Height	Max. 2400mm				Max. 2400mm				Max. 2500mm			

■ For Multiple Synchronized Sliding Door FD30-HRP/FD50-HRP check page 9-10/13-14.

■ For Stackable Partition Door System FDP40P/FDP40V check page 27-28/29-30.

### UPPER ROLLER SELECTION GUIDE

	Type	Installation	Advantage
<p>RECESSED MOUNT</p>	FD30-H FD50-H	Snap-In	<ul style="list-style-type: none"> <li>• Easy door installation and adjustment</li> <li>• Adjustment by phillips head screwdriver</li> <li>• Small gap between door and upper track</li> </ul>
<p>SIDE MOUNT</p>	FD30-H	Snap-In	<ul style="list-style-type: none"> <li>• Easy door installation and adjustment</li> <li>• Adjustment by phillips head screwdriver</li> <li>• Small gap between door and upper track</li> </ul>
<p>SURFACE MOUNT</p>	FD50-H FD80-H	Easy Hang	<ul style="list-style-type: none"> <li>• Easy door installation and adjustment</li> <li>• No door boring required</li> </ul>
<p>RECESSED MOUNT</p>	FD80-H	Easy Hang	<ul style="list-style-type: none"> <li>• Easy door installation and adjustment</li> <li>• Small gap between door and upper track</li> </ul>

■ Door Installation

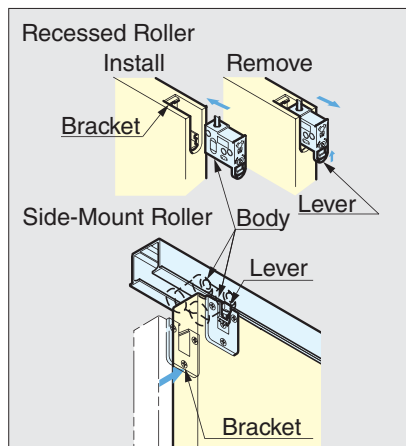

Insert Bracket to hang door.  
To remove door, click the lever and pull out the Bracket.

■ Height Adjustment

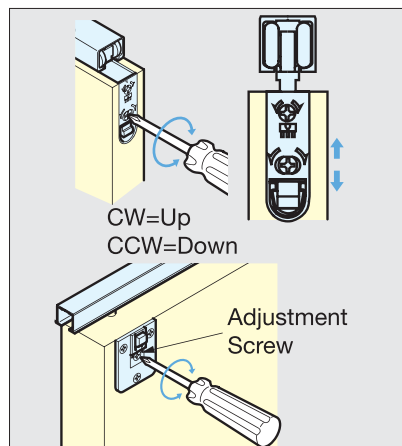

Simply turn the adjustment screw with a screwdriver.

■ Side Adjustment (FD30H,FD50-H)

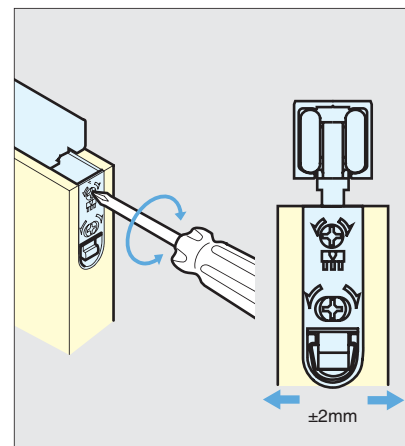

Simply turn the adjustment screw with a screwdriver.  
±2mm adjustable.

■ Soft Closer Mechanism

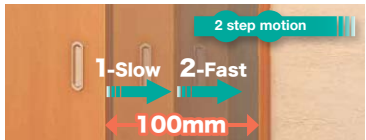
<p>Soft Close Unit</p>  <p>2 Step sequential soft close motion</p>	<ul style="list-style-type: none"> <li>• Soft closer mechanism integrated in upper roller</li> <li>• One-Way or Two-Way soft closer unit in single unit</li> </ul>
<p>Long soft close stroke</p>  <p>Soft close option</p>	<ul style="list-style-type: none"> <li>• 2 step sequential motion</li> <li>First stage - Damper catches and slows the door</li> <li>Second stage - Damper soft closes the door</li> </ul>

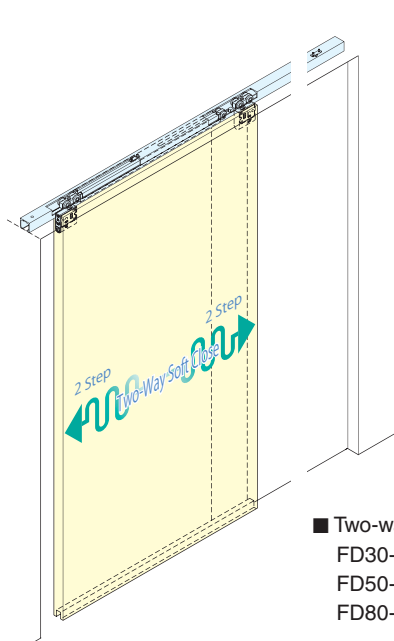

■ Two-way soft close  
FD30-H  
FD50-H  
FD80-H

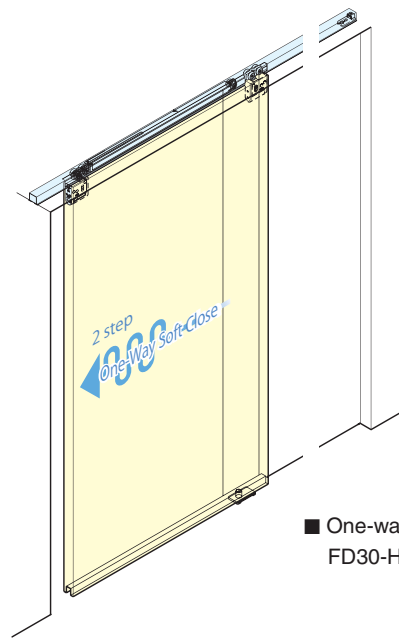

■ One-way soft close  
FD30-H

# SLIDING DOOR SYSTEM

# FD30-H



Type	a	b	c	d
	Two-Way Soft Close	One-Way Soft Close	Standard Sliding	Standard Sliding
Roller	Recessed Mount	Recessed Mount	Recessed Mount	Side Mount
Door Weight	Max. 30kg per door			
Door Thickness (Min.)	24mm	24mm	24mm	28mm
Door Width	590-1000mm	510-1000mm	Max. 1000mm	Max. 1000mm
Door Height	Max. 2400mm			
Height Adjustment	-3/+4mm	-3/+4mm	±4mm	±4mm
Side Adjustment	±2mm	±2mm	±2mm	-

- Thin profile allows flexible design on various applications
- Soft-Close Type available by selecting each roller type
- Various parts available for many applications
- \*Designed for interior use, not exterior.

**a b c** Door Preparation

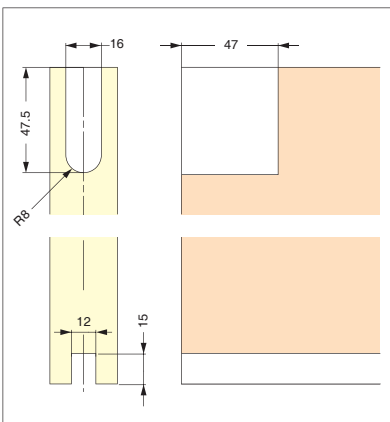

**a** FD30 / Recessed Mount Roller / Two-Way Soft Close

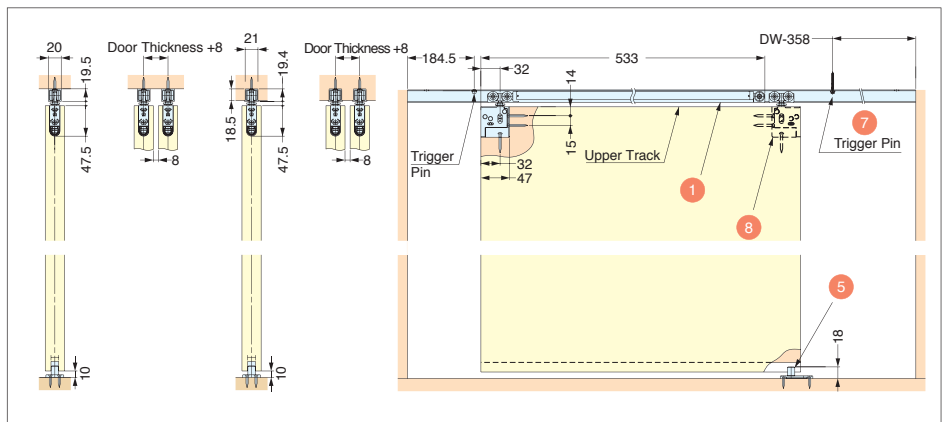

**d** Door Preparation

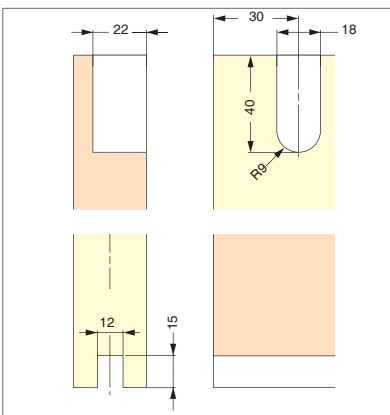

**b** FD30 / Recessed Mount Roller / One-Way Soft Close

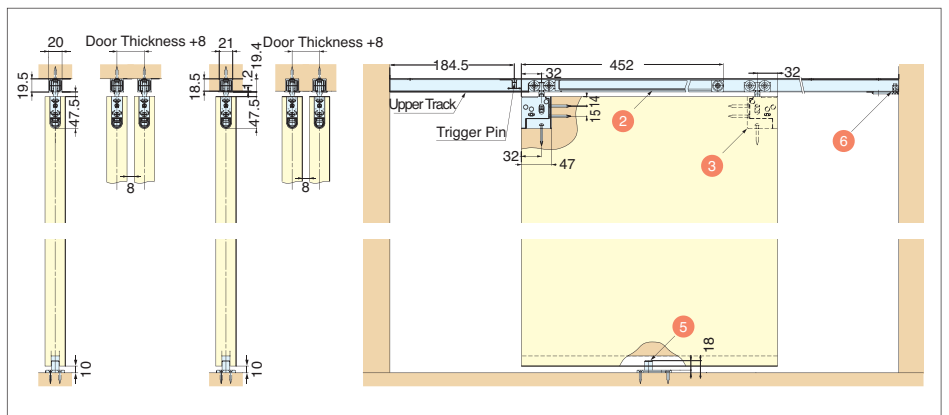

**c** FD30 / Recessed Mount Roller / Standard Sliding

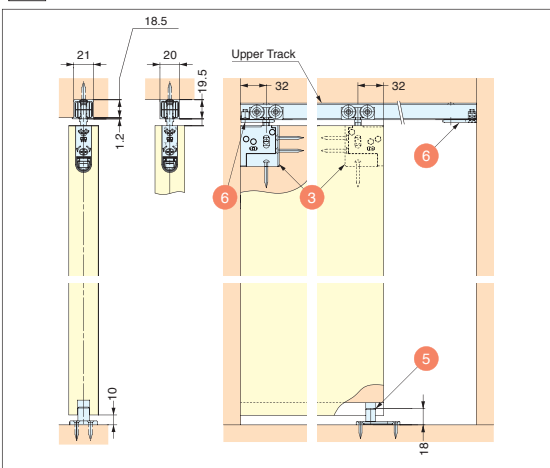



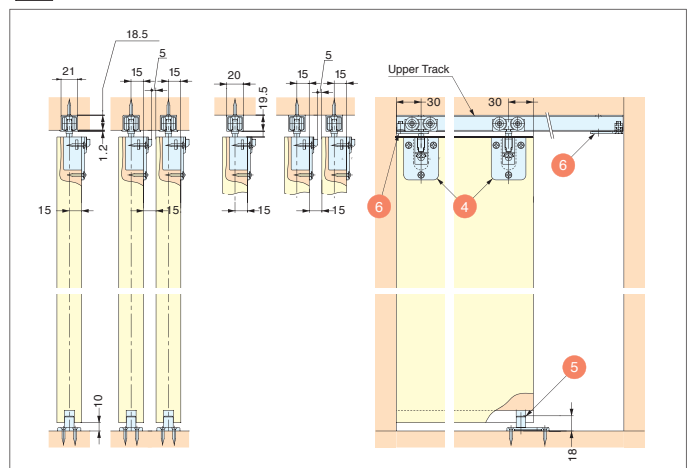





**d** FD30 / Side Mount Roller / Standard Sliding







Parts Set (per door)		Necessary Parts	
Please refer to "Qty [a] - [d]" for parts included in each set.			
	Item Code	Item No.	Description
[a]	250-020-829	FD30-DHCP	Recessed Roller Two-Way Soft Close
[b]	250-017-901	FD30-HCP	Recessed Roller One-Way Soft Close
[c]	250-017-903	FD30-HHP	Recessed Roller Standard Sliding
[d]	250-017-904	FD30-HUP	Side-Mount Roller Standard Sliding

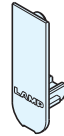

## Parts Included

No.	Qty				Item Code	Description
	[a]	[b]	[c]	[d]		
1	1 pcs	-	-	-	250-020-781 Recessed-Roller Two-Way Soft Closer FD30-WRH-DSC	<ul style="list-style-type: none"> <li>Material Zinc Alloy / Polyacetal</li> <li>Finish Yellow Zinc Chromate / Light Brown</li> </ul> 
2	-	1 pcs	-	-	250-017-137 Recessed-Roller One-Way Soft Closer FD30-WRH-SC	<ul style="list-style-type: none"> <li>Material Zinc Alloy / Polyacetal</li> <li>Finish Yellow Zinc Chromate / Light Brown</li> </ul> 
3	-	1 pcs	2 pcs	-	250-017-135 Recessed Roller FD30-WRH	<ul style="list-style-type: none"> <li>Material Zinc Alloy / Polyacetal</li> <li>Finish Yellow Zinc Chromate / Light Brown</li> </ul> 
4	-	-	-	2 pcs	250-017-142 Side Mount Roller FD30-WRU	<ul style="list-style-type: none"> <li>Material Steel / Polyacetal</li> <li>Finish Yellow Zinc Chromate / Brown</li> </ul> 
5	1 pcs	1 pcs	1 pcs	1 pcs	250-017-151 Floor Guide FD30-HBG	<ul style="list-style-type: none"> <li>Material Steel / Polyamide</li> <li>Finish Yellow Zinc Chromate / Light Brown</li> </ul> 
6	-	1 pcs	2 pcs	2 pcs	250-019-969 End Stopper FD30-HTST-DB	<ul style="list-style-type: none"> <li>Material Steel / Polyamide</li> <li>Finish Yellow Zinc Chromate / Brown</li> </ul> 
7	1 pcs	-	-	-	250-019-967 Trigger Pin (Included in item no. 1) FD30-TRG	<ul style="list-style-type: none"> <li>Material Steel</li> <li>Finish Zinc Chromate</li> </ul> 
8	1 pcs	-	-	-	250-020-837 Recessed Roller For Two-Way Soft Closer FD30-WRH-N	<ul style="list-style-type: none"> <li>Material Zinc Alloy / Polyacetal</li> <li>Finish Yellow Zinc Chromate / Light Brown</li> </ul> 

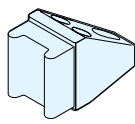
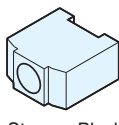
Cover Cap		Necessary Parts	
No.	Item Code	Description	
9	250-018-785	 Cover Cap	<ul style="list-style-type: none"> <li>Material Polypropylene</li> <li>Finish White</li> </ul>
	FD30-WRH-CP-WT		
	250-017-138		<ul style="list-style-type: none"> <li>Material Polypropylene</li> <li>Finish Light Brown</li> </ul>
	FD30-WRH-CP		
	250-018-786		
FD30-WRH-CP-DB			

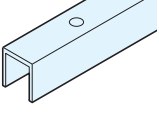
## Optional Parts

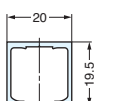
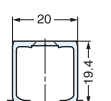
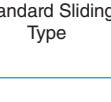
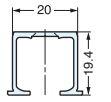
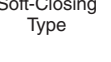
No.	Item Code	Description	
10	250-018-497	 Door Stopper	<ul style="list-style-type: none"> <li>Material Zinc Alloy / Rubber</li> <li>Finish Silver</li> </ul>
	FD30-HTKY		
11	250-017-139	 Stopper Block	<ul style="list-style-type: none"> <li>Material Polyacetal</li> <li>Finish Dark Brown</li> </ul>
	FD30-HSB		
12	250-017-156	 Bottom Guide	<ul style="list-style-type: none"> <li>Material Polyamide</li> <li>Finish Light Brown</li> </ul>
	FD30-HGW		
13	250-021-996	 Door Guide Track	<ul style="list-style-type: none"> <li>Material Aluminum</li> <li>Finish Anodized Silver</li> </ul>
	FD30-HBRT1000SIL		

Upper Track				Necessary Parts					
Mounting	Item Code	Length	Dimension	Description	Mounting	Item Code	Length	Dimension	Description
Surface Mount	250-017-131	1820mm		<ul style="list-style-type: none"> <li>Material Aluminum</li> <li>Finish Anodized Silver</li> </ul>	Recessed Mount	250-017-133	1820mm		<ul style="list-style-type: none"> <li>Material Aluminum</li> <li>Finish Anodized Silver</li> </ul>
	FD30-TRM1820SIL					FD30-TRH1820SIL			
	250-017-966					250-017-968			
	FD30-TRM2730SIL	2730mm	Standard Sliding Type	<ul style="list-style-type: none"> <li>Material Aluminum</li> <li>Finish Anodized Silver</li> </ul>		FD30-TRH2730SIL	2730mm		<ul style="list-style-type: none"> <li>Material Aluminum</li> <li>Finish Anodized Silver</li> </ul>
	250-017-970	3640mm				FD30-TRH3640SIL	3640mm		
	FD30-TRM3640SIL	1820mm				FD30-TRH1820SCSIL	1820mm		
	FD30-TRM1820SCSIL	2730mm	Soft-Closing Type	<ul style="list-style-type: none"> <li>Material Aluminum</li> <li>Finish Anodized Silver</li> </ul>		250-017-980	2730mm		<ul style="list-style-type: none"> <li>Material Aluminum</li> <li>Finish Anodized Silver</li> </ul>
	250-017-978	3640mm				FD30-TRH2730SCSIL	3640mm		
	FD30-TRM2730SCSIL	1820mm				FD30-TRH1820SCSIL	1820mm		
FD30-TRM3640SCSIL	2730mm	Soft-Closing Type	<ul style="list-style-type: none"> <li>Material Aluminum</li> <li>Finish Anodized Silver</li> </ul>	250-017-984	3640mm		<ul style="list-style-type: none"> <li>Material Aluminum</li> <li>Finish Anodized Silver</li> </ul>		
250-017-982	1820mm			FD30-TRH3640SCSIL	1820mm				
FD30-TRM1820SCSIL	2730mm			FD30-TRH2730SCSIL	2730mm				
FD30-TRM2730SCSIL	3640mm	Soft-Closing Type	<ul style="list-style-type: none"> <li>Material Aluminum</li> <li>Finish Anodized Silver</li> </ul>	250-017-984	3640mm		<ul style="list-style-type: none"> <li>Material Aluminum</li> <li>Finish Anodized Silver</li> </ul>		
250-017-982	1820mm			FD30-TRH3640SCSIL	1820mm				
FD30-TRM1820SCSIL	2730mm			FD30-TRH2730SCSIL	2730mm				

# MULTIPLE SYNCHRONIZED SLIDING DOOR

# FD30-HRP

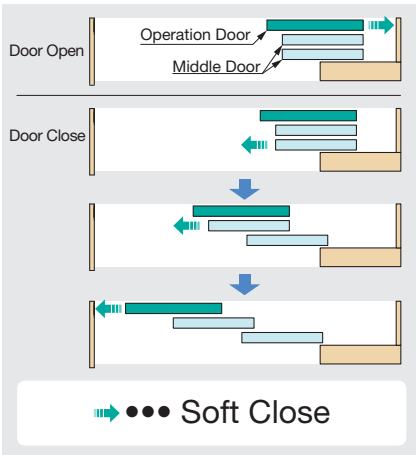

Type	FD30-HRP / 2 or 3 Doors Synchronized Sliding Style
Door Thickness	30-38mm
Door Width	590-1000mm
Door Weight	Max. 30kg per door
Height Adjustment	-3/+4mm
Side Adjustment	±2mm

### Maximum Opening Clearance

#### 2 Doors

Maximum Opening  
**1840mm**  
\*Door Width 1000mm

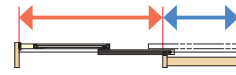

#### 3 Doors

Maximum Opening  
**2760mm**  
\*Door Width 1000mm



Parts Set		Necessary Parts	
Please refer to "Qty [a] - [b]" for parts included in each set.			
Item No.	Description		
	Roller	Function	
[a] 250-022-267 FD30-HRP2	Recessed	2Doors Synchronized	
[b] 250-022-268 FD30-HRP3	Recessed	3Doors Synchronized	

#### Parts Included

No.	Qty		Item Code	Description
	a	b		
1	1 pcs	1 pcs	250-026-118 Recessed-Roller Soft-Closer (Two-Way) FD30-WRH-DSC-A	• Material Zinc Alloy / Polyacetal • Finish Yellow Zinc Chromate / Light Brown
2	1 pcs	2 pcs	250-017-137 Recessed-Roller Soft-Closer (One-Way) FD30-WRH-SC	• Material Zinc Alloy / Polyacetal • Finish Yellow Zinc Chromate / Light Brown
3	2 pcs	3 pcs	250-020-837 Recessed-Roller FD30-WRH-N	• Material Zinc Alloy / Polyacetal • Finish Yellow Zinc Chromate / Light Brown
4	2 pcs	3 pcs	250-019-967 Trigger-Pin FD30-TRG	• Material / Steel • Finish Yellow Zinc Chromate
5	1 set	2 sets	250-022-261 End Stopper FD30-HRGU	• Material SUS 304 / POM • Finish / Grey, Plain
6	1 pcs	2 pcs	250-022-262 Door Guide (Door Mount) FD30-HRDG	• Material SUS 304 / POM • Finish / Grey, Plain

No.	Qty		Item Code	Description
	a	b		
7	1 pcs	1 pcs	250-022-263 Door Guide (Wall Mount) FD30-HBGF	• Material SUS 304 / POM • Finish / Grey, Plain
8	1 pcs	1 pcs	250-022-264 Block for Bottom Guide FD30-HRDB	• Material / EPDM • Finish / Black
9	1 pcs	2 pcs	250-022-265 Bumper Block FD30-HBB	• Material Steel / EPDM • Finish Chromate / Black
10	2 pcs	3 pcs	250-022-266 Guide Track FD30-HBDR1000	• Material / ABS • Finish / Black

### Cover Cap

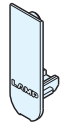

### Necessary Parts

No.	Item Code	Description
11	250-018-785 FD30-WRH-CP-WT	 <ul style="list-style-type: none"> <li>• Material Polypropylene</li> <li>• Finish WT=White CP=Light Brown DB=Dark Brown</li> </ul>
	250-017-138 FD30-WRH-CP	
	250-018-786 FD30-WRH-CP-DB	

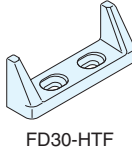
### Optional Parts

No.	Item Code	Description
12	250-017-157 Guide for Door FD30-HTF	 <ul style="list-style-type: none"> <li>• Material / Polyamide</li> <li>• Finish / Light Brown</li> </ul>

### Upper Track

Mounting	Item Code	Length	Dimension	Description	Mounting	Item Code	Length	Dimension	Description
Surface Mount	250-017-805 FD30-TRM1820SCSIL	1820mm		<ul style="list-style-type: none"> <li>• Material Aluminum</li> <li>• Finish Anodized Silver</li> </ul>	Recessed Mount	250-017-807 FD30-TRH1820SCSIL	1820mm		<ul style="list-style-type: none"> <li>• Material Aluminum</li> <li>• Finish Anodized Silver</li> </ul>
	250-017-978 FD30-TRM2730SCSIL	2730mm				250-017-980 FD30-TRH2730SCSIL	2730mm		
	250-017-982 FD30-TRM3640SCSIL	3640mm				250-017-984 FD30-TRH3640SCSIL	3640mm		

■ Door Preparation

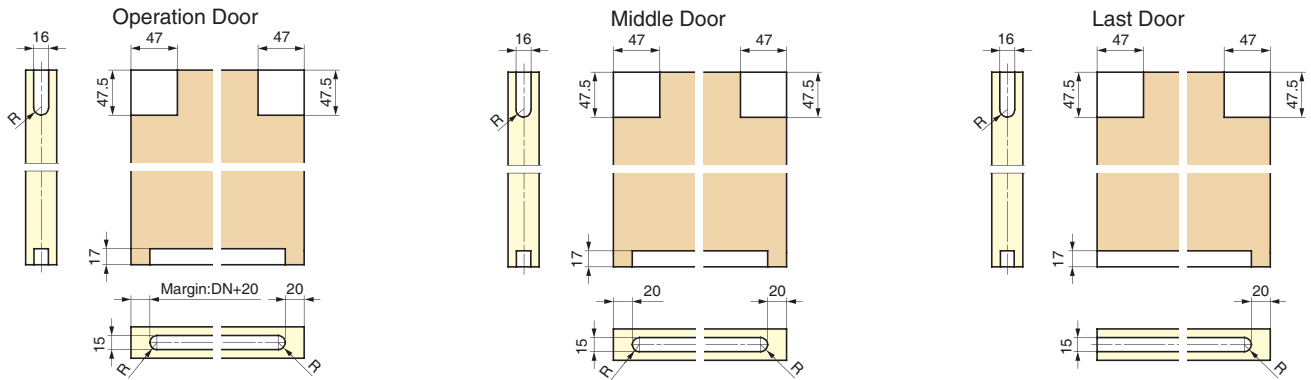

a FD30 / Synchronized Sliding / 2 doors

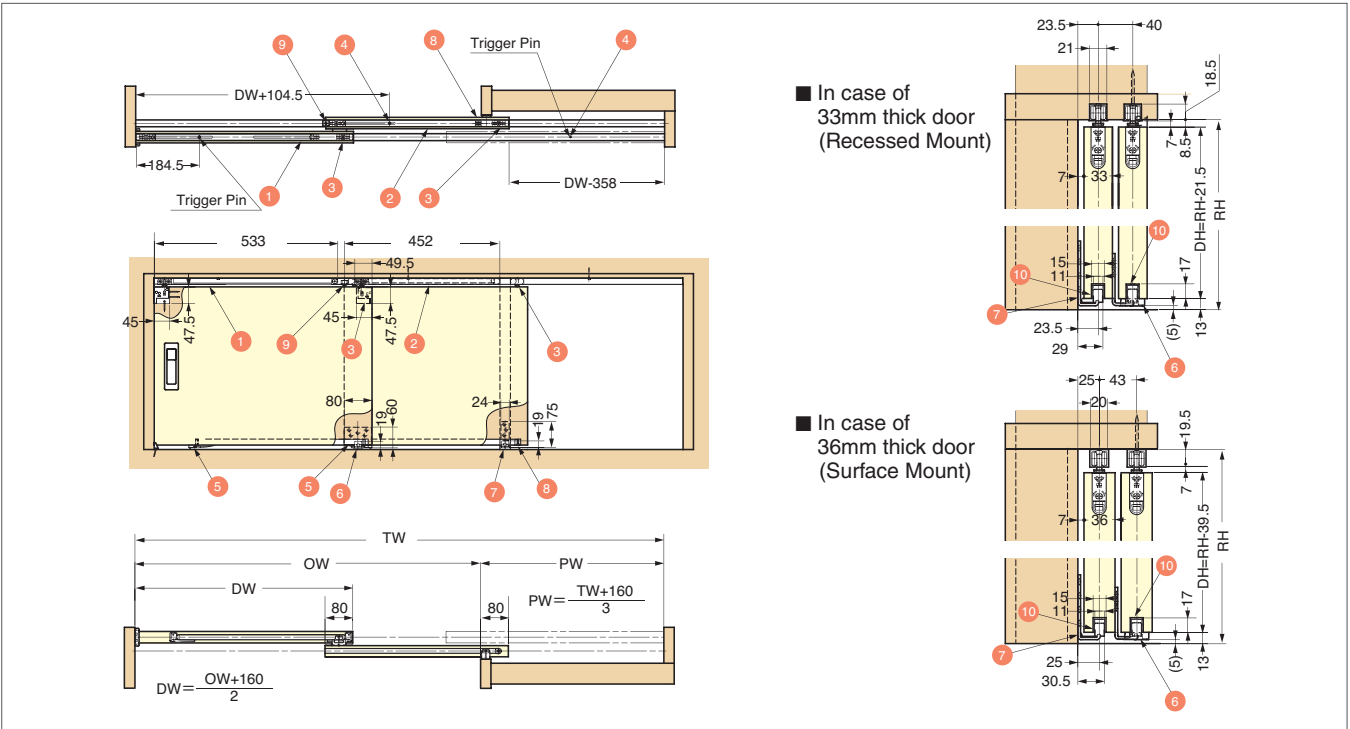

b FD30 / Synchronized Sliding / 3 doors

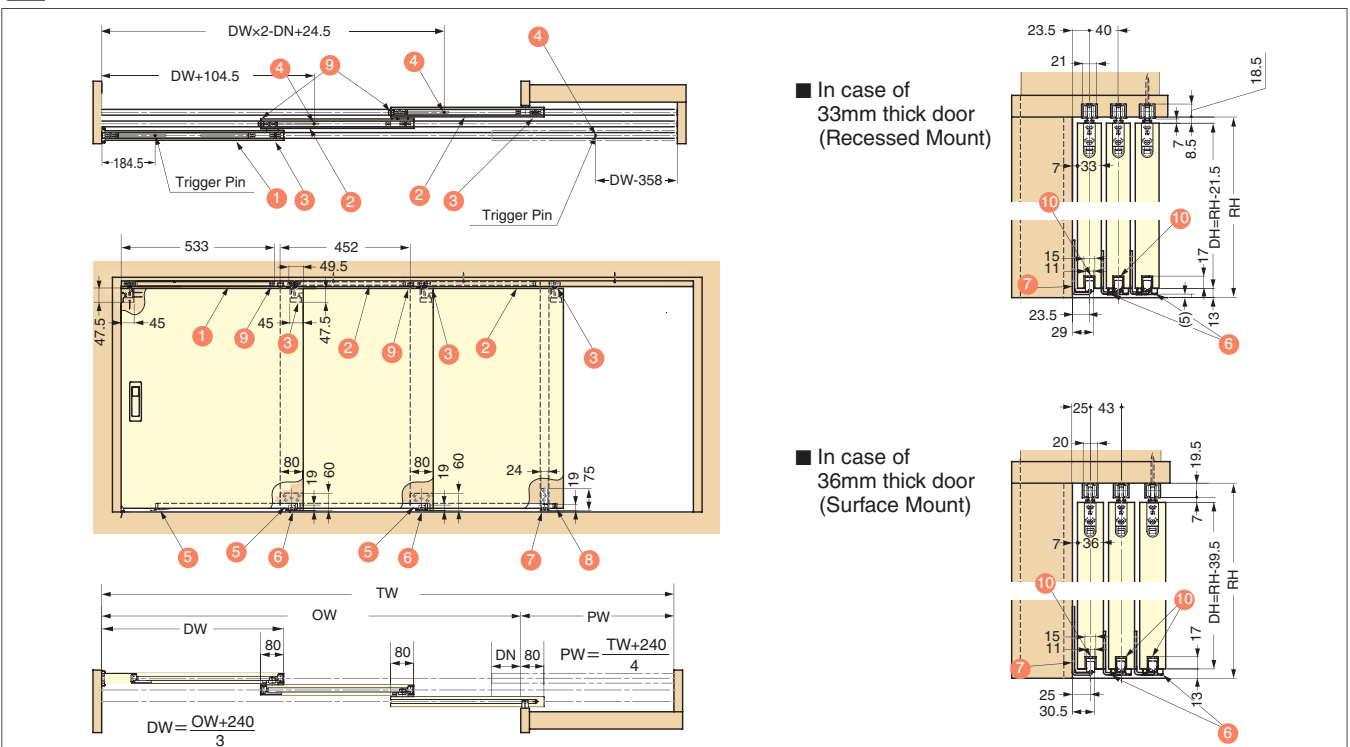

# SLIDING DOOR SYSTEM

# FD50-H



Type	a	b	c	d
	Two-Way Soft Close	Standard Sliding	Two-Way Soft Close	Standard Sliding
Roller	Recessed Mount	Recessed Mount	Surface Mount	Surface Mount
Door Weight	Max. 50kg per door			
Door Thickness (Min.)	24mm	24mm	30mm	30mm
Door Width	680-1500mm	Max. 1500mm	774-1500mm	Max. 1500mm
Door Height	Max. 2400mm			
Height Adjustment	-3/+4mm		±4mm	
Side Adjustment	±2mm		-	

- Thin profile allows flexible design on various applications
- Soft-Close Type available by selecting each roller type
- Various parts available for many applications
- \*Designed for interior use, not exterior.

a FD50 / Recessed Mount Roller / Two-Way Soft Close

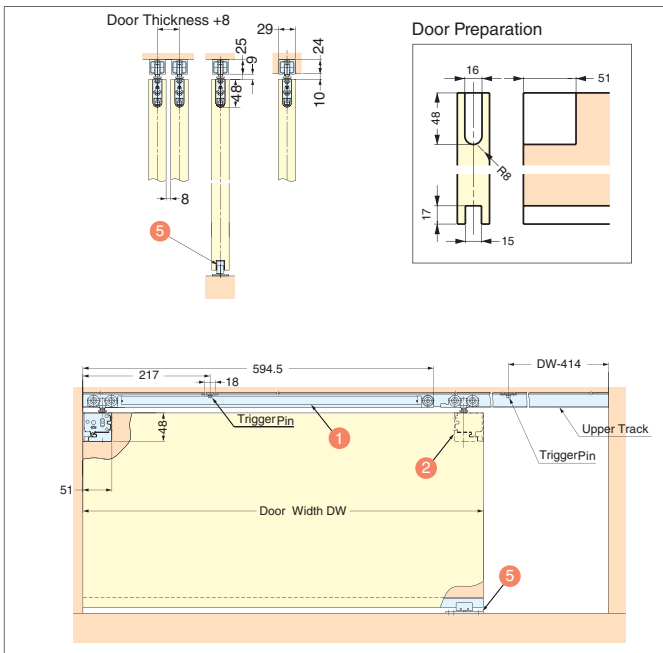

b FD50 / Recessed Mount Roller / Standard Sliding

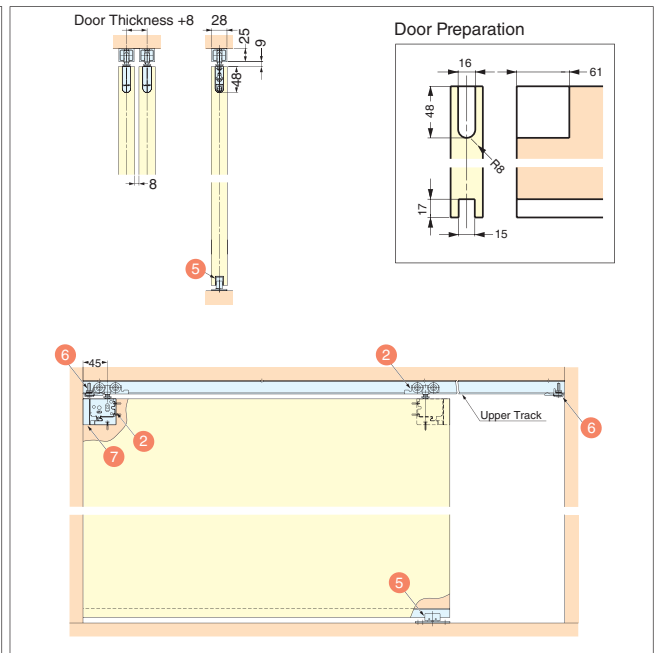

c FD50 / Surface Mount Roller / Two-Way Soft Close

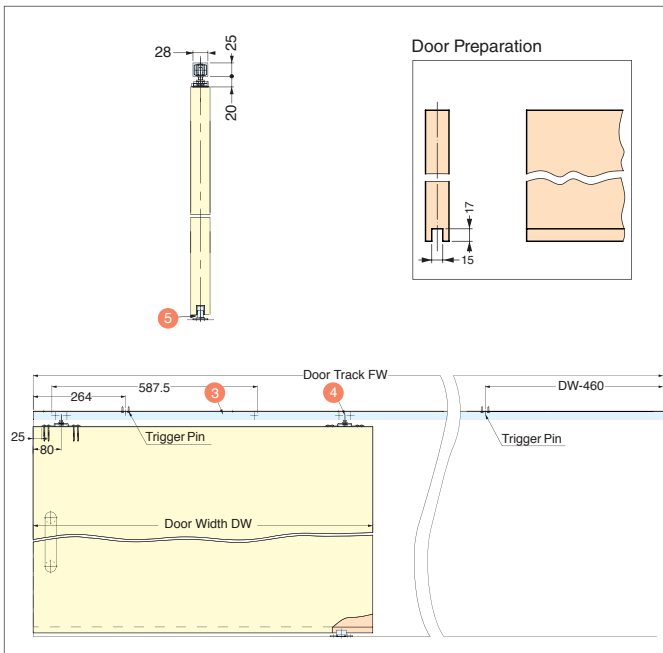



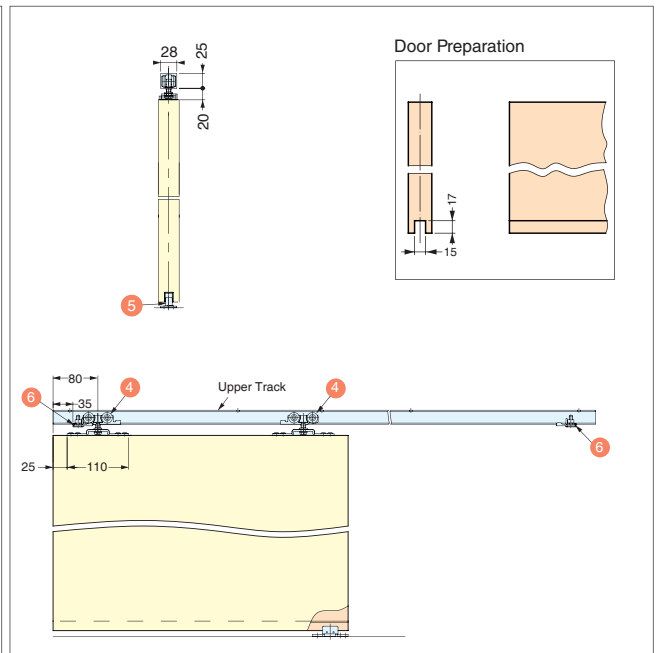



d FD50 / Surface Mount Roller / Standard Sliding



Parts Set (per door)		Necessary Parts	
Please refer to "Qty [a-d]" for parts included in each set.			
Item Code	Item No.	Description	
[a]	250-020-791	FD50-DHCP	Recessed Roller Two-Way Soft Close
[b]	250-020-792	FD50-HHP-LBR	Recessed Roller Standard Sliding
[c]	250-023-991	FD50-DHCOMP	Surface Mount Two-Way Soft Close
[d]	250-023-990	FD50-HMP	Surface Mount Standard Sliding

**Parts Included**

No.	Qty				Item Code	Description
	[a]	[b]	[c]	[d]		
1	1	-	-	-	250-020-764	 <ul style="list-style-type: none"> <li>Material Steel / Polyacetal</li> <li>Finish Chromate / Grey</li> </ul>
	2	-	-	-	FD50-WRH-DSC	
2	1	2	-	-	250-020-765	 <ul style="list-style-type: none"> <li>Material Zinc Alloy / Polyacetal</li> <li>Finish Chromate / Grey</li> </ul>
	2	-	-	-	FD50-WRH	
3	-	-	1	-	250-022-902	 <ul style="list-style-type: none"> <li>Material Steel / Polyacetal</li> <li>Finish Chromate / White</li> </ul>
	-	-	2	-	FD50-WRM-DSC	
4	-	-	1	2	250-022-901	 <ul style="list-style-type: none"> <li>Material Zinc Alloy / Polyacetal</li> <li>Finish Nickel / White</li> </ul>
	-	-	2	2	FD50-WRM	
5	1	1	1	1	250-020-773	 <ul style="list-style-type: none"> <li>Material SUS 304 / Polyacetal</li> <li>Finish Plain / White</li> </ul>
	1	1	1	1	FD50-BG18	
6	-	2	-	2	250-020-772	 <ul style="list-style-type: none"> <li>Material Steel</li> <li>Finish Chromate</li> </ul>
	-	2	-	2	FD50-HTST	

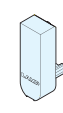
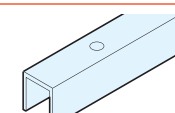
No.	Qty				Item Code	Description
	[a]	[b]	[c]	[d]		
7	-	2	-	-	250-020-778	 <ul style="list-style-type: none"> <li>Material Polypropylene</li> <li>Finish Light Brown</li> </ul>
	-	2	-	-	FD50-WRH-SCP-LBR	
8	1	1	1	1	250-019-971	 <ul style="list-style-type: none"> <li>Material Aluminum</li> <li>Finish Anodized Silver</li> </ul>
	1	1	1	1	FD30-HBRT1500SIL	

**Cover Cap**

**Necessary Parts for [a]**

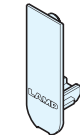
No.	Item Code	Description
9	250-020-777	 <ul style="list-style-type: none"> <li>Material Polypropylene</li> <li>Finish WT=White LBR=Light Brown DBR=Dark Brown</li> </ul>
	FD50-WRH-CP-WT	
	250-020-775	
	FD50-WRH-CP-LBR	
	250-020-776	
	FD50-WRH-CR-DBR	Cover Cap

**Optional Parts**

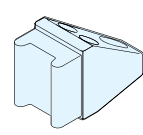
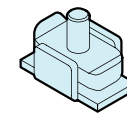
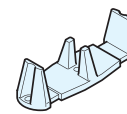
No.	Item Code	Description
10	250-018-497	 <ul style="list-style-type: none"> <li>Material Zinc Alloy / Rubber</li> <li>Finish Grey</li> </ul>
	FD30-HTKY	
11	250-020-817	 <ul style="list-style-type: none"> <li>Material Steel</li> <li>Finish Chromate</li> </ul>
	FD50-HSB	
12	250-017-156	 <ul style="list-style-type: none"> <li>Material Polyamide</li> <li>Finish Light Brown</li> </ul>
	FD30-HGW	

**Upper Track**

**Necessary Parts**

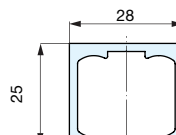
Mounting	Item Code	Length	Dimension	Description
Surface Mount & Recessed Mount	250-020-766	1820mm		<ul style="list-style-type: none"> <li>Material Aluminum</li> <li>Finish Anodized Silver</li> </ul>
	FD50-TRM1820SIL			
	250-020-768	2730mm		<ul style="list-style-type: none"> <li>Material Aluminum</li> <li>Finish Anodized Silver</li> </ul>
	FD50-TRM2730SIL			
	250-020-770	3640mm		<ul style="list-style-type: none"> <li>Material Aluminum</li> <li>Finish Anodized Silver</li> </ul>
FD50-TRM3640SIL				

# MULTIPLE SYNCHRONIZED SLIDING DOOR

# FD50-HRP

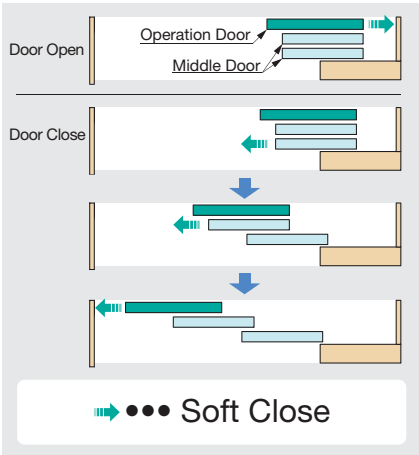

Type	FD50-HRP / 2 or 3 Doors Synchronized Sliding Style
Door Thickness	30-38mm
Door Width	680-1200mm
Door Weight	Max. 50kg per door
Height Adjustment	-3/+4mm
Side Adjustment	±2mm

### Maximum Opening Clearance

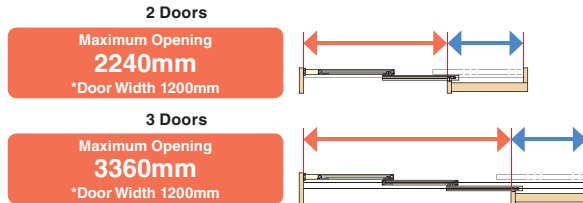

Parts Set		Necessary Parts		
		Please refer to Qty" a - b "for parts included in each set.		
	Item Code	Item No.	Description	
a	250-023-211	FD50-HRP2	2 Doors Synchronized	
b	250-023-212	FD50-HRP3	3 Doors Synchronized	

### Parts Included

No.	Qty		Item Code	Description
	a	b		
1	2 pcs	3 pcs	250-020-764 Recessed Roller Soft-Close + Trigger Pin FD50-WRH-DSC	<ul style="list-style-type: none"> <li>Material Steel / Polyacetal</li> <li>Finish Chromate / Grey</li> </ul>
	4 pcs	6 pcs		
2	2 pcs	3 pcs	250-020-765 Recessed Roller FD50-WRH	<ul style="list-style-type: none"> <li>Material Zinc Alloy / Polyacetal</li> <li>Finish Chromate / Grey</li> </ul>
3	2 pcs	3 pcs	250-019-971 Door Guide Track FD30-HBRT1500SIL	<ul style="list-style-type: none"> <li>Material Aluminium</li> <li>Finish Anodized Silver</li> </ul>
4	1 pcs	2 pcs	250-020-817 Stopper Block FD50-HSB	<ul style="list-style-type: none"> <li>Material Steel</li> <li>Finish Chromate</li> </ul>
5	1 pcs	2 pcs	250-022-262 Door Guide (Door Mount) FD30-HRDG	<ul style="list-style-type: none"> <li>Material SUS 304 / POM</li> <li>Finish Grey, Plain</li> </ul>
6	1 pcs	1 pcs	250-022-263 Door Guide (Wall Mount) FD30-HBGF	<ul style="list-style-type: none"> <li>Material SUS 304 / POM</li> <li>Finish Grey, Plain</li> </ul>

No.	Qty		Item Code	Description
	a	b		
7	1 set	2 sets	250-022-261 End Stopper FD30-HRGU	<ul style="list-style-type: none"> <li>Material SUS 304 / POM</li> <li>Finish Grey, Plain</li> </ul>
8	1 pcs	1 pcs	250-022-264 Block for Bottom Guide FD30-HRDB	<ul style="list-style-type: none"> <li>Material EPDM</li> <li>Finish Black</li> </ul>

Cover Cap		Necessary Parts		
No.	Item Code	Description		
9	250-020-777 FD50-WRH-CP-WT		<ul style="list-style-type: none"> <li>Material Polypropylene</li> <li>Finish WT=White, LBR=Light Brown, DBR=Dark Brown</li> </ul>	
	250-020-775 FD50-WRH-CP-LBR			
	250-020-776 FD50-WRH-CP-DBR			

Optional Parts		
No.	Item Code	Description
10	250-017-157 Guide for Door FD30-HTF	<ul style="list-style-type: none"> <li>Material / Polyamide</li> <li>Finish / Light Brown</li> </ul>

Upper Track		Necessary Parts		
Mounting	Item Code	Length	Dimension	Description
Surface Mount	250-020-766 FD50-TRM1820SIL	1820mm		<ul style="list-style-type: none"> <li>Material : Aluminum</li> <li>Finish : Anodized Silver</li> </ul>
	250-020-768 FD50-TRM2730SIL	2730mm		
	250-020-770 FD50-TRM3640SIL	3640mm		

■ Door Preparation

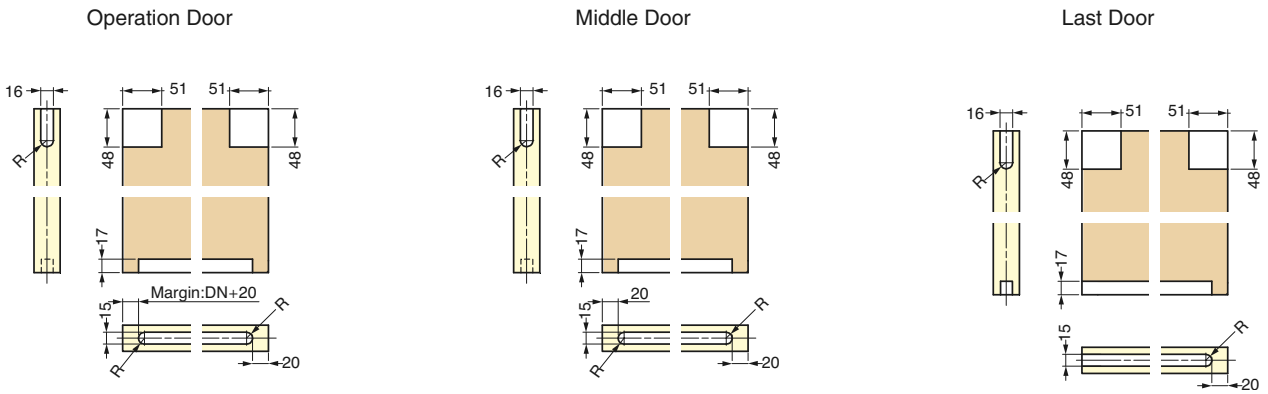

a FD50 / Synchronized Sliding / 2 doors

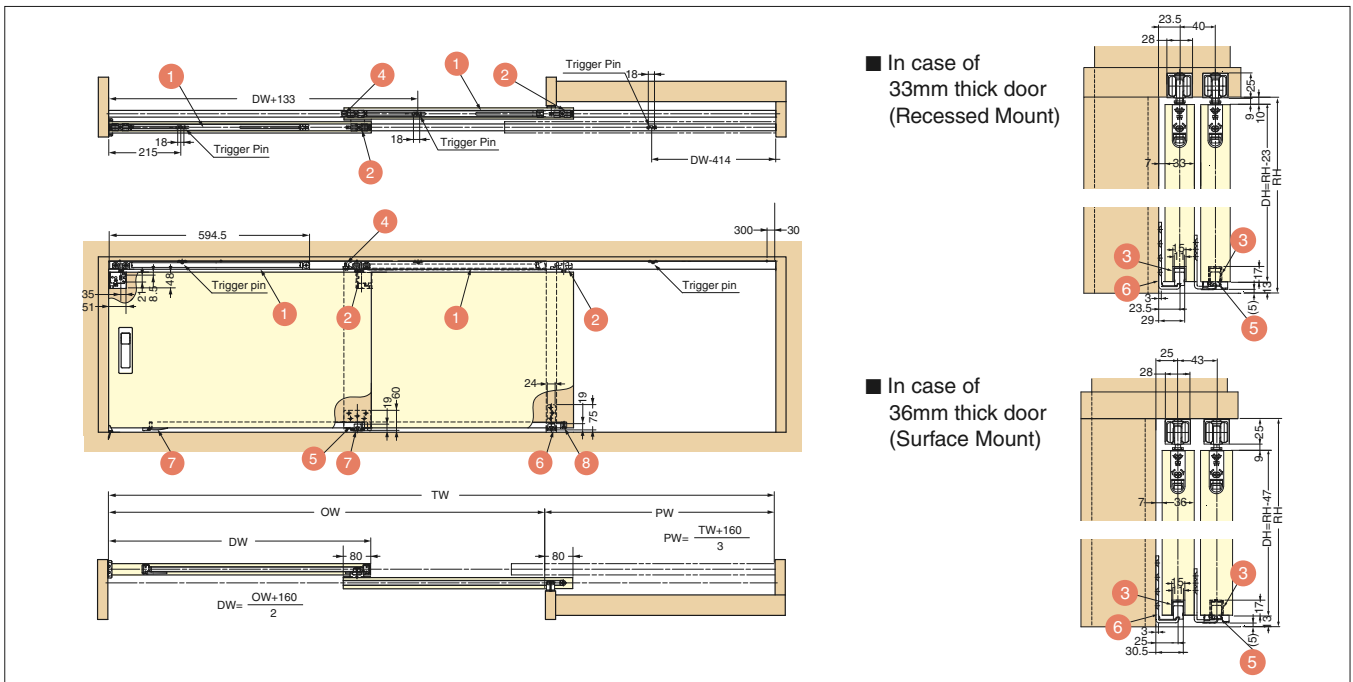

b FD50 / Synchronized Sliding / 3 doors

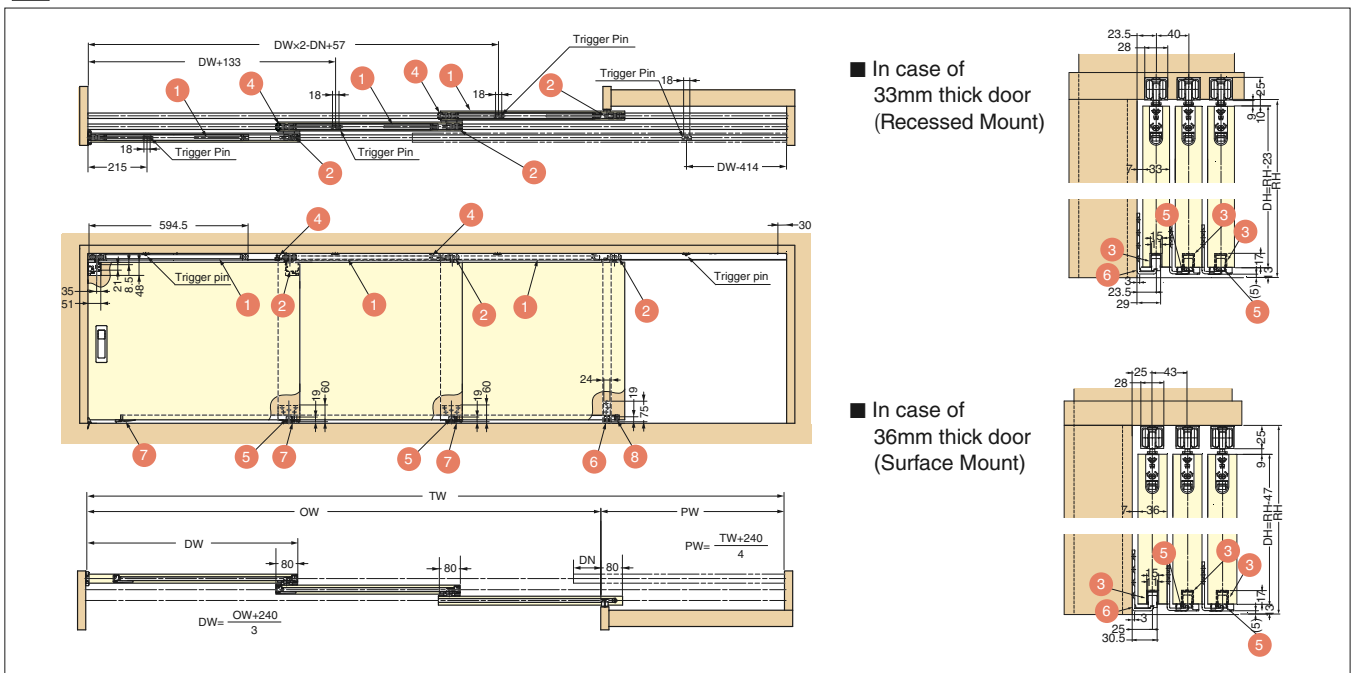

# SLIDING DOOR SYSTEM

# FD80-H



Type	a	b	c	d
	Two-Way Soft Close	Standard Sliding	Two-Way Soft Close	Standard Sliding
Roller	Recessed Mount	Recessed Mount	Surface Mount	Surface Mount
Door Weight	Max. 80kg per door			
Door Thickness (Min.)	34mm	34mm	30mm	30mm
Door Width	784-1500mm	Max. 1500mm	784-1500mm	Max. 1500mm
Door Height	Max. 2500mm			
Height Adjustment	-1/+4mm		±4mm	

- Heavy Duty version
- Soft-Close Type available by selecting each roller type
- Surface mount system for easy installation - No door boring is required
- Easy door installation - Simply hang the door onto the rollers
- Easy height adjustment

**a** FD80 / Recessed Mount Roller / Two-Way Soft Close

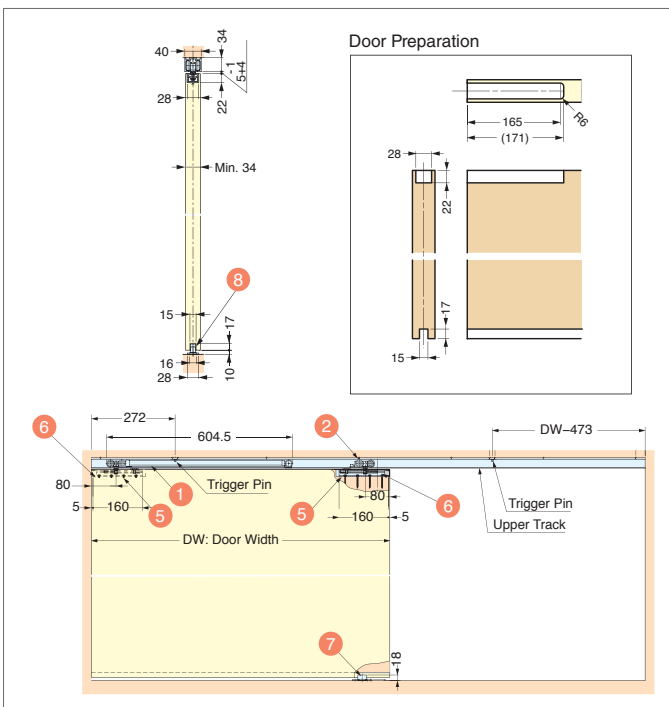

**c** FD80 / Surface Mount Roller / Two-Way Soft Close

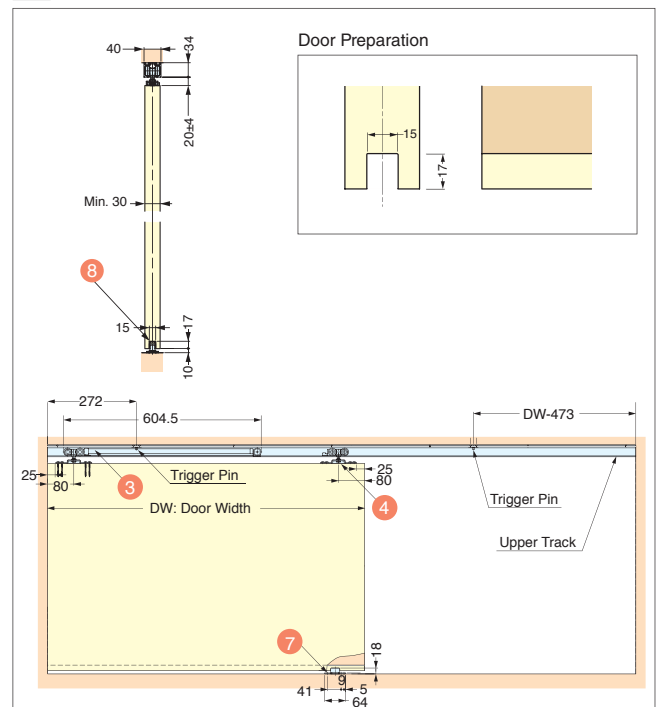

**b** FD80 / Recessed Mount Roller / Standard Sliding

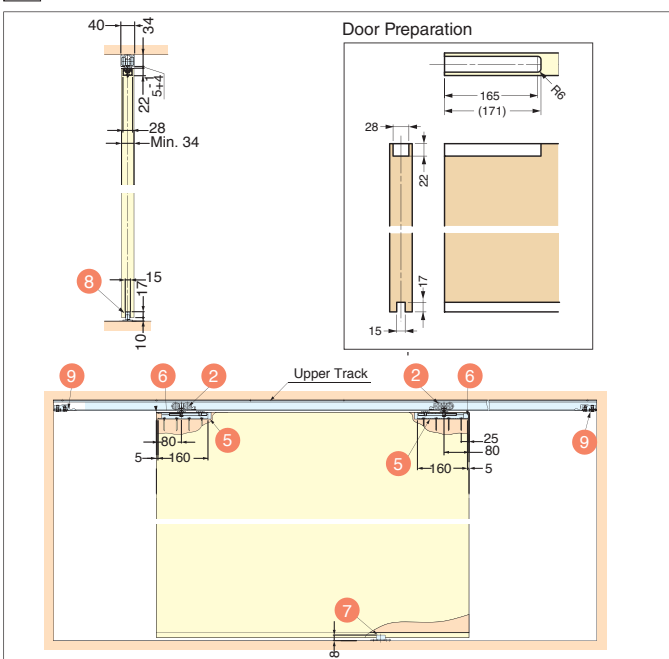



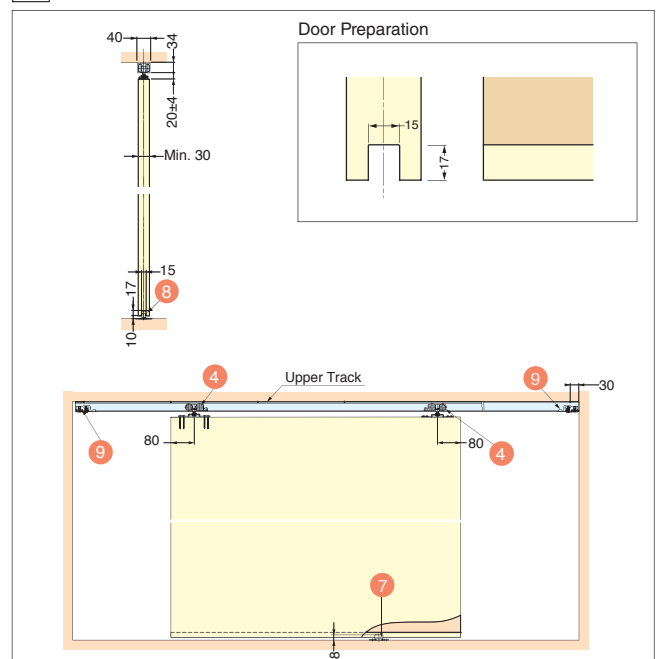

**d** FD80 / Surface Mount Roller / Standard Sliding









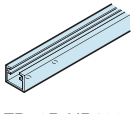

Parts Set (per door)		Necessary Parts	
Please refer to "Qty a-d" for parts included in each set.			
	Item Code	Item No.	Description
a	250-022-253	FD80-DHCHP	Recessed Mount Roller Two-Way Soft Close
b	250-022-254	FD80-HHP	Recessed Mount Roller Standard Sliding
c	250-022-255	FD80-DHCMP	Surface Mount Two-Way Soft Close
d	250-022-256	FD80-HMP	Surface Mount Standard Sliding

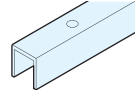
Parts Included

No.	Qty				Item Code	Description
	a	b	c	d		
1	1	-	-	-	250-022-239	 <ul style="list-style-type: none"> <li>Material Zinc Alloy / Polyacetal / Aluminum</li> <li>Finish Nickel / Black</li> </ul>
	2	-	-	-	FD80-WRH-DSC	
	1	2	-	-	250-022-241	 <ul style="list-style-type: none"> <li>Material Zinc Alloy / Polyacetal / Aluminum</li> <li>Finish Nickel / Natural</li> </ul>
3	-	-	1	-	250-022-240	 <ul style="list-style-type: none"> <li>Material Steel / Polyacetal</li> <li>Finish Chromate / Black</li> </ul>
	-	-	2	-	FD80-WRM-DSC	
4	-	-	1	2	250-022-242	 <ul style="list-style-type: none"> <li>Material Zinc Alloy / Polyacetal</li> <li>Finish Nickel / Natural</li> </ul>
5	2	2	-	-	250-120-608	 <ul style="list-style-type: none"> <li>Material Aluminum</li> <li>Finish Anodized Silver</li> </ul>

No.	Qty				Item Code	Description
	a	b	c	d		
6	2	2	-	-	250-121-142	 <ul style="list-style-type: none"> <li>Material Elastomer (TPE)</li> <li>Finish Black</li> </ul>
	-	-	-	-	FD70B-EC	
7	1	1	1	1	250-020-773	 <ul style="list-style-type: none"> <li>Material SUS304 / POM</li> <li>Finish Plain / White</li> </ul>
	-	-	-	-	FD50-BG18	
8	1	1	1	1	250-019-971	 <ul style="list-style-type: none"> <li>Material Aluminum</li> <li>Finish Anodized Silver</li> </ul>
	-	-	-	-	FD30-HBRT1500SIL	
9	-	2	-	2	250-022-250	 <ul style="list-style-type: none"> <li>Material Steel / Polyacetal</li> <li>Finish Chromate / White</li> </ul>
	-	-	-	-	FD80-HTST	

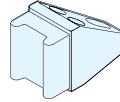
Optional Parts

No.	Item Code	Description
10	250-018-497	 <ul style="list-style-type: none"> <li>Material Zinc Alloy / Rubber</li> <li>Finish Grey</li> </ul>
	FD30-HTKY	
11	250-022-251	 <ul style="list-style-type: none"> <li>Material Steel / EPDM</li> <li>Finish Chromate / Black</li> </ul>
	FD80-HSB	

Upper Track

Necessary Parts

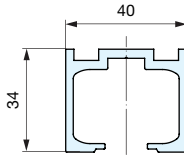
Mounting	Item Code	Length	Dimension	Description	
Surface Mount & Recessed Mount	250-022-244	2000mm		<ul style="list-style-type: none"> <li>Material Aluminum</li> <li>Finish Anodized Silver</li> </ul>	
	FD80-TRM2000SL				
	250-022-246	2730mm			<ul style="list-style-type: none"> <li>Material Aluminum</li> <li>Finish Anodized Silver</li> </ul>
	FD80-TRM2730SL				
	250-022-248	3640mm			
FD80-TRM3640SL					

## ALUMINUM FRAME SLIDING DOOR SYSTEM

FD80-AF



Type	a	b	c	d
	Two-Way Soft Close	Standard Sliding	Two-Way Soft Close	Standard Sliding
Roller	Recessed Mount	Recessed Mount	Surface Mount	Surface Mount
Door Weight	Max. 80kg per door			
Glass Thickness	5 or 6mm			
Door Width	784-1500mm	Max. 1500mm	804-1500mm	Max. 1500mm
Door Height	Max. 3000mm			
Height Adjustment	-1/+4mm		±4mm	

- Two-way soft closer option available.
- Surface or recessed mount roller available.
- Thick aluminum profile provides excellent rigidity preventing door flex.
- Ball bearing roller provides ultra smooth movement.
- Easy assembly and installation.
- Intermediate support not needed when door size within H 2200mm x W 900mm.
- No rail on floor needed.
- Swing door version available for total coordination.
- Black frame available by special order only.

\* Intermediate support required when either door height or door width exceeds standard size. Pictures shown below are door size examples which require intermediate support.

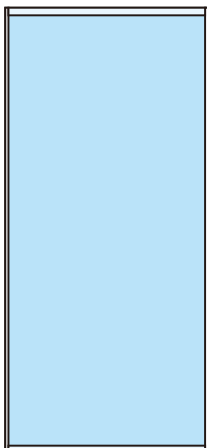

Standard Size  
(Smaller than H 2200 x W 900)

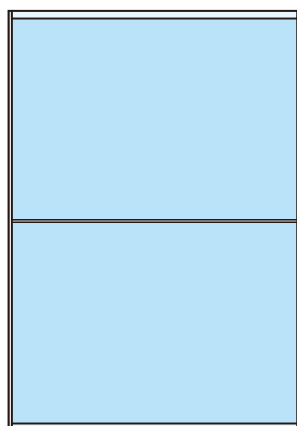

1 Support  
(Smaller than H 2000 x W 1600)

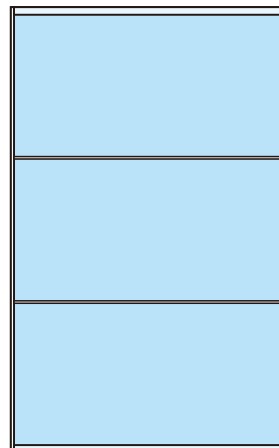

2 Supports  
(Smaller than H 2200 x W 1500)

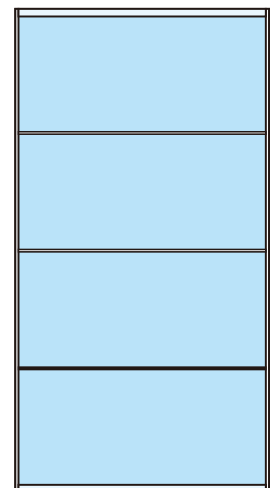

3 Supports  
(Smaller than H 2500 x W 1300)

Parts Set (per door)		Necessary Parts	
		Please refer to "Qty [a]-[d]" for parts included in each set.	
Item Code	Item No.	Description	
[a] 250-022-257	FD80-DHCHP-AF	Recessed Mount Roller Two Way Soft-Close	
[b] 250-022-258	FD80-HHP-AF	Recessed Mount Roller Standard Sliding	
[c] 250-022-259	FD80-DHCMP-AF	Surface Mount Roller Two Way Soft-Close	
[d] 250-022-260	FD80-HMP-AF	Surface Mount Roller Standard Sliding	

**Parts Included**

No.	Qty				Item Code	Description
	[a]	[b]	[c]	[d]		
1	1 pcs	-	-	-	250-022-239	<ul style="list-style-type: none"> <li>Material Steel / Polyacetal</li> <li>Finish Chromate / Black</li> <li>With 2pcs Trigger Pins</li> </ul>
					FD80-WRH-DSC	
2	1 pcs	2 pcs	-	-	250-022-241	<ul style="list-style-type: none"> <li>Material Zinc Alloy / Polyacetal</li> <li>Finish Nickel / Natural</li> </ul>
					FD80-WRH	
3	-	-	1 pcs	-	250-022-240	<ul style="list-style-type: none"> <li>Material Steel / Polyacetal</li> <li>Finish Chromate / Black</li> <li>With 2pcs Trigger Pins</li> </ul>
					FD80-WRM-DSC	
4	-	1 pcs	2 pcs	-	250-022-242	<ul style="list-style-type: none"> <li>Material Zinc Alloy / Polyacetal</li> <li>Finish Nickel / Natural</li> </ul>
					FD80-WRM	
5	1 pcs	1 pcs	1 pcs	1 pcs	250-020-773	<ul style="list-style-type: none"> <li>Material SUS 304 / POM</li> <li>Finish Plain / White</li> </ul>
					FD50-BG18	
6	-	2 pcs	-	2 pcs	250-022-250	<ul style="list-style-type: none"> <li>Material Steel / Polyacetal</li> <li>Finish Chromate / White</li> </ul>
					FD80-HTST	
7	-	-	1 pcs	1 pcs	250-022-243	<ul style="list-style-type: none"> <li>Material Steel</li> <li>Finish Chromate</li> </ul>
					FD80-AFB	
8	2 pcs	2 pcs	-	-	250-121-141	<ul style="list-style-type: none"> <li>Material Elastomer</li> <li>Finish Grey</li> </ul>
					AF-25HB-EC	

Aluminum Frame Parts (for one door)			
No.	Item Code	Description	
9	250-940-965		<ul style="list-style-type: none"> <li>Material Aluminum</li> <li>Finish Matte Silver</li> </ul>
	AF-25-W01-2.5M		
10	250-121-116		<ul style="list-style-type: none"> <li>Material Aluminum</li> <li>Finish Matte Silver</li> </ul>
	AF-25-W01-3M		
11	250-120-070		<ul style="list-style-type: none"> <li>Material Aluminum</li> <li>Finish Matte Silver</li> </ul>
	AF-25-W02		
12	250-940-967		<ul style="list-style-type: none"> <li>Material Aluminum</li> <li>Finish Matte Silver</li> </ul>
	AF-25-W03 (Optional)		
13	250-120-056		<ul style="list-style-type: none"> <li>Material Zinc Alloy</li> <li>Finish Matte Chrome</li> </ul>
	AF-25-P04		
14	250-940-960		<ul style="list-style-type: none"> <li>Material Elastomer</li> <li>Finish Light Grey</li> </ul>
	AF-25-P02		
15	250-181-197		<ul style="list-style-type: none"> <li>Material Elastomer</li> <li>Finish Light Grey</li> </ul>
	AF-25-P15		
16	250-940-961		<ul style="list-style-type: none"> <li>Material Elastomer</li> <li>Finish Light Grey</li> </ul>
	AF-25-P03 (Optional)		
17	250-181-196		<ul style="list-style-type: none"> <li>Material Elastomer</li> <li>Finish Light Grey</li> </ul>
	AF-25-P16 (Optional)		
18	270-940-959		<ul style="list-style-type: none"> <li>Material Elastomer</li> <li>Finish Light Grey</li> </ul>
	AF-25-P01-25		
19	100-010-386		<ul style="list-style-type: none"> <li>Material Zinc Alloy</li> <li>Finish Matte Chrome</li> </ul>
	MN799Z160E101 (Optional)		
20	250-181-199		<ul style="list-style-type: none"> <li>Material SUS 304</li> <li>Finish Plain</li> </ul>
	AF-25-HS		

※1 [a] [b] : 2pcs / door [c] [d] : 4pcs / door

Upper Track		Necessary Parts		
Mounting	Item Code	Length	Dimension	Description
Surface Mount & Recessed Mount	250-022-244	2000mm		<ul style="list-style-type: none"> <li>Material Aluminum</li> <li>Finish Anodized Silver</li> </ul>
	FD80-TRM2000SL			
	250-022-246	2730mm		
	FD80-TRM2730SL			
	250-022-248	3640mm		
FD80-TRM3640SL				

a FD80-AF / Recessed Mount Roller / Two-Way Soft Close

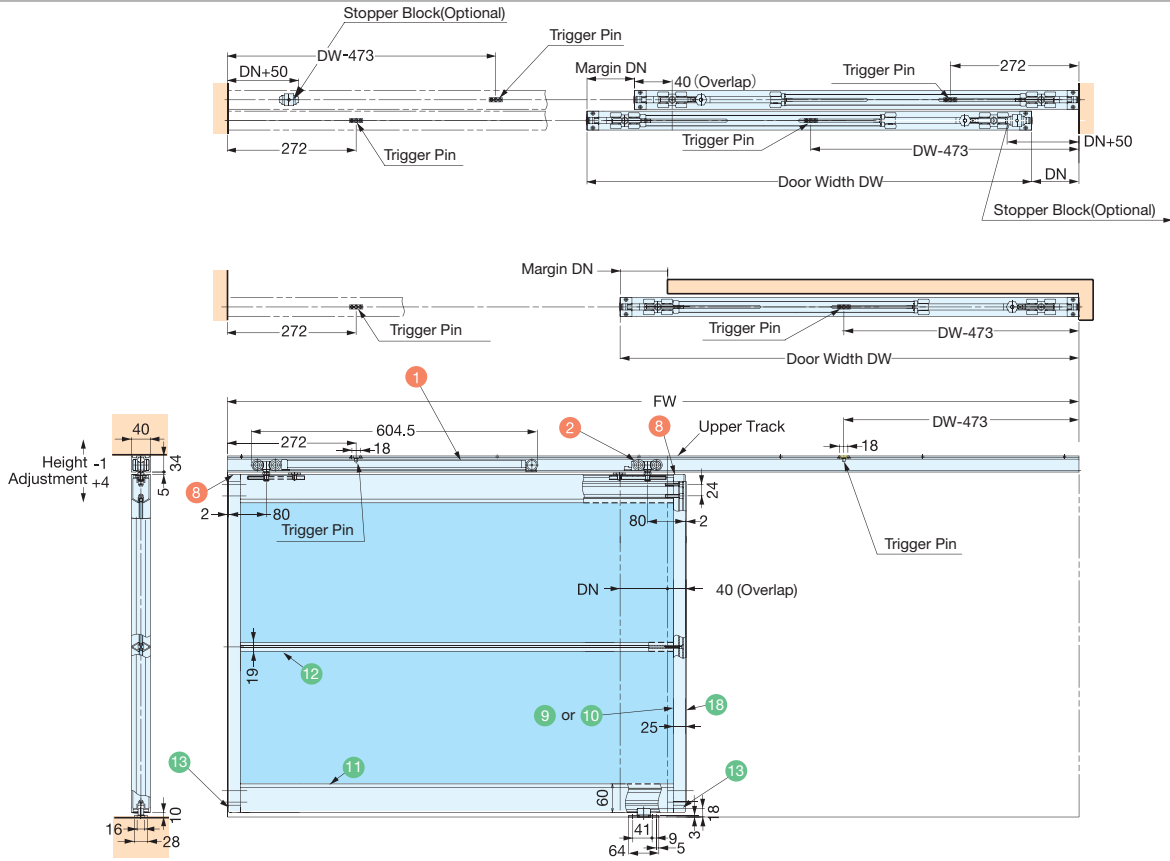

b FD80-AF / Recessed Mount Roller / Standard Sliding

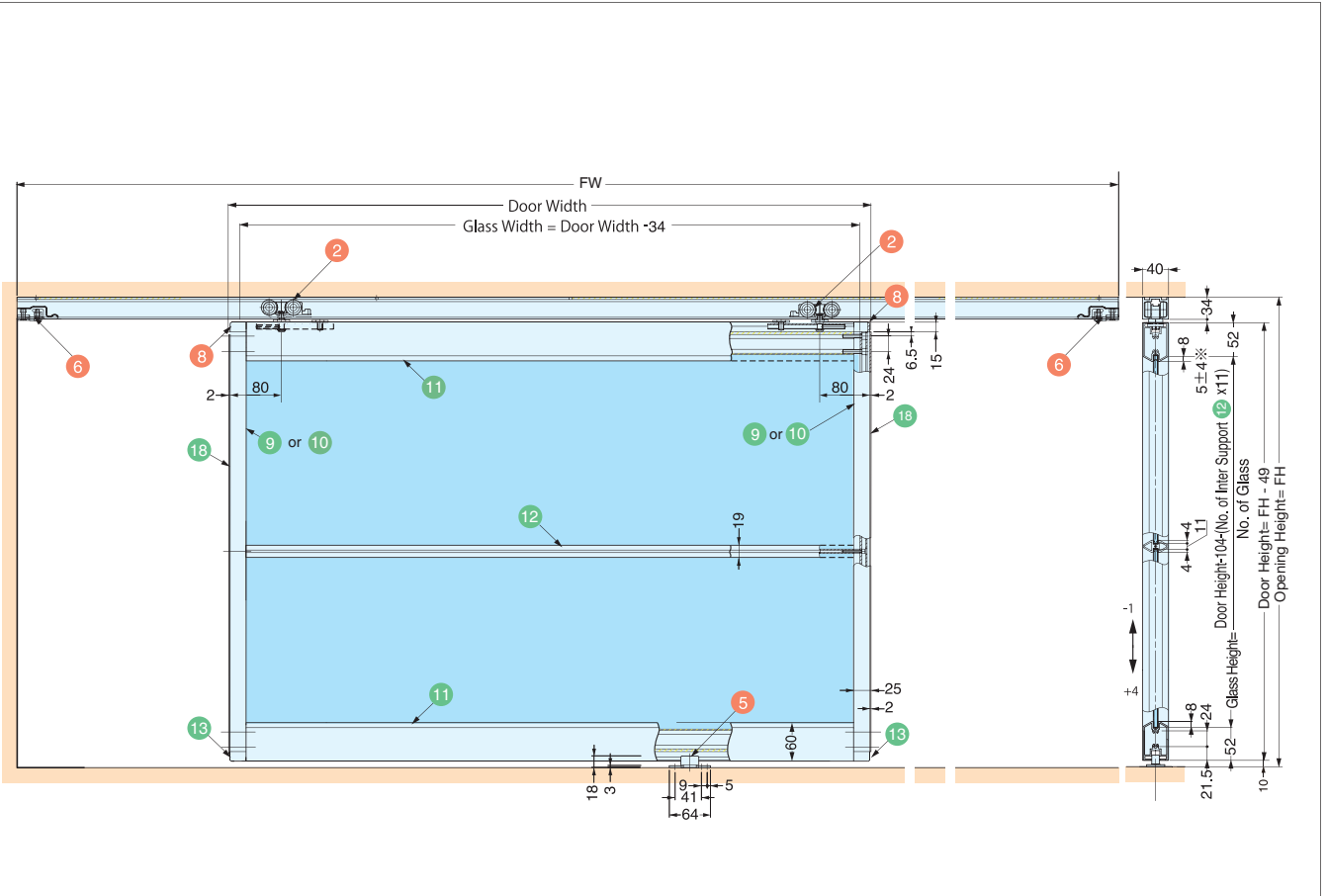

**C** FD80-AF / Surface Mount Roller / Two-Way Soft Close

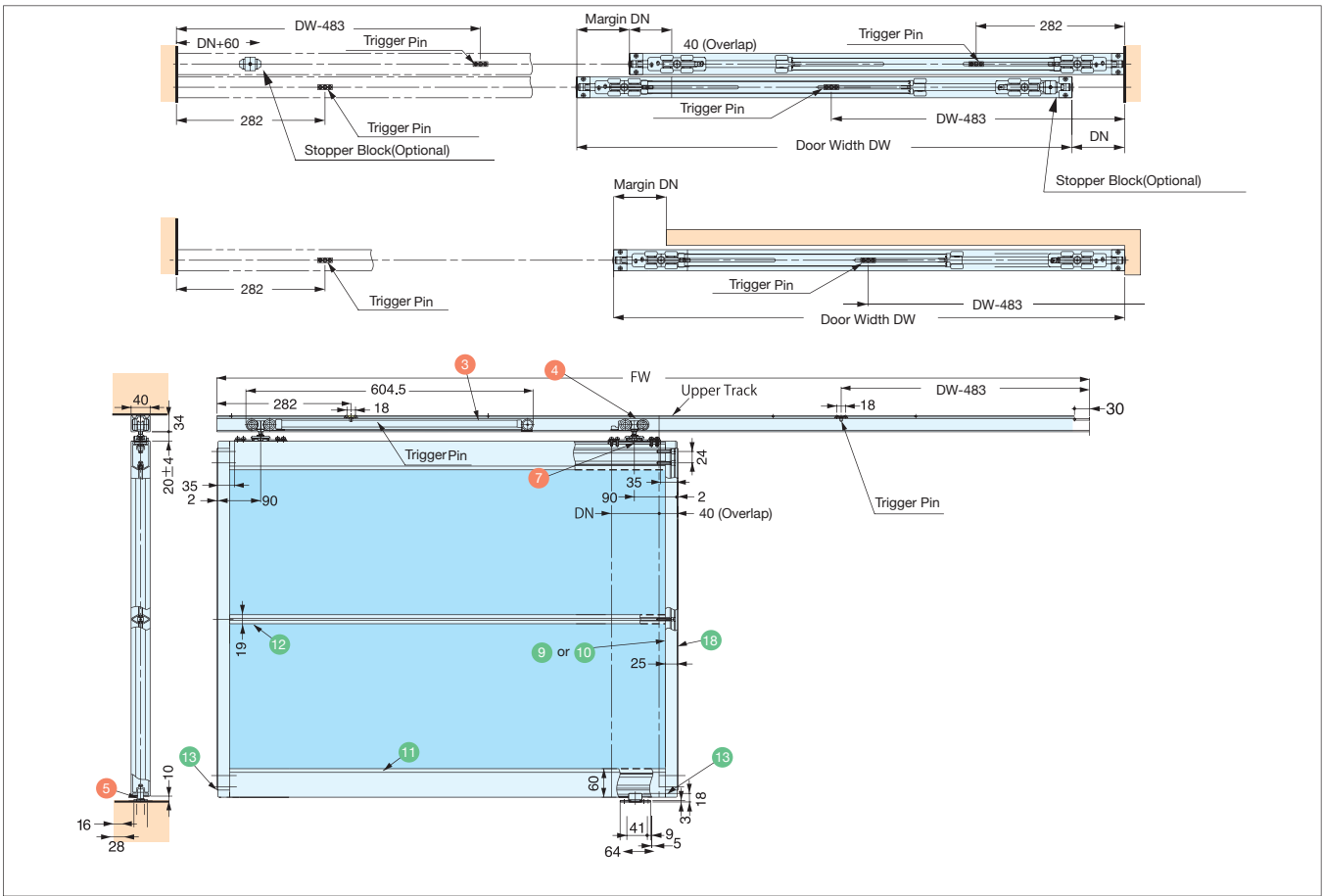

**d** FD80-AF / Surface Mount Roller / Standard Sliding

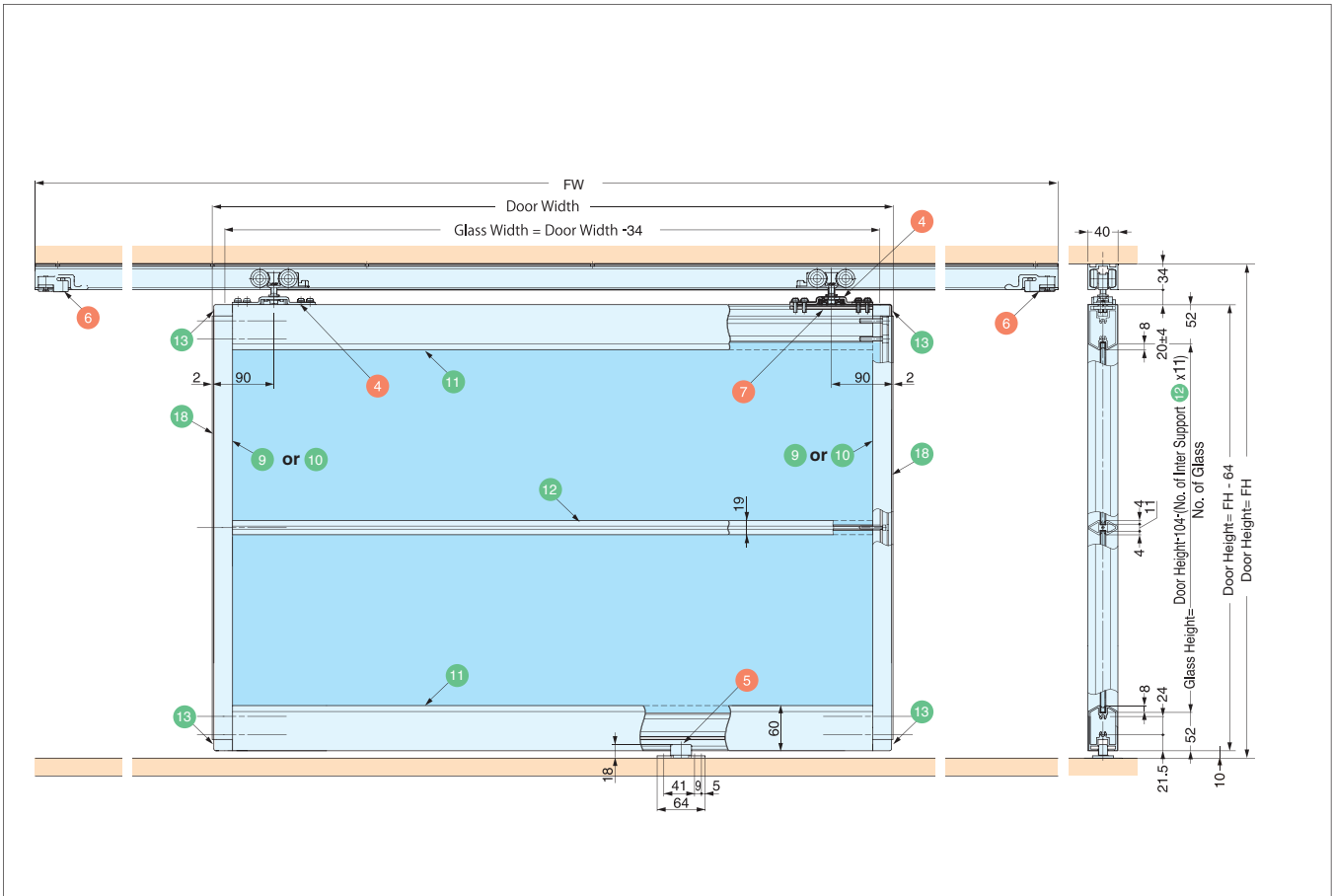

# SELF CLOSING SLIDING DOOR SYSTEM

## LM-80, LM-80G

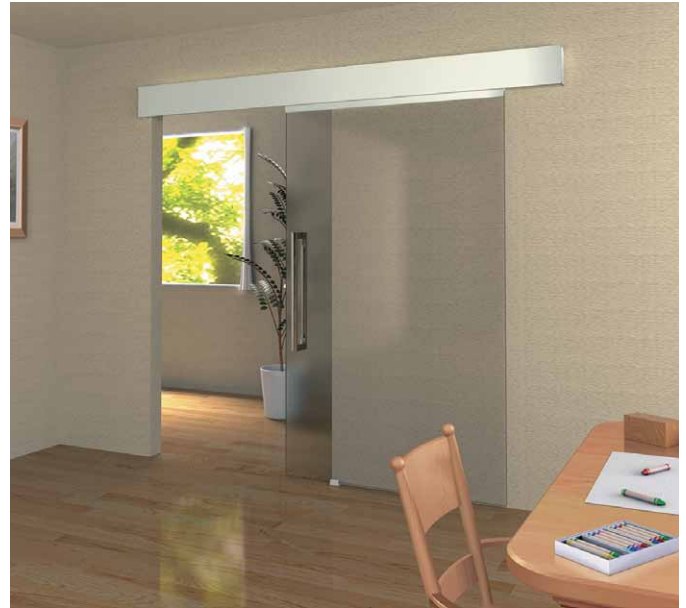

Item No.	LM-80 (For Wood) / LM-80G (For Glass)
Door Width	700-1200mm
Door Thickness	Wood : 28-40mm / Glass : 8-12mm
Door Weight	30-80kg/Door
Door Travel	Max. 1100mm (in case of door width 1200mm)

- Self closing sliding door system – no electricity required
- Equipped with damper for smooth and soft closing, eliminating slamming.
- No-pre-drilled holes on glass needed for installation.
- Door catch included to hold door in fully open position.

### Part Details

No.	1	2	3	4	5	6	7
Name	Damper	Roller A	Roller B	Gear Rack	Spring	Stopper Roller	Door Stopper
Necessary Qty	LM-80	1 pcs	1 pcs	1 pcs	1 pcs	1 pcs	2 pcs
	LM-80G	1 pcs	1 pcs	1 pcs	1 pcs	1 pcs	2 pcs

No.	8	9	10	11	12	13	14
Name	Stopper Plate	Height Adjustment Spacer	Upper Rail	Roller Bracket (For Wood)	Bottom Roller Guide	Anchor	Glass Bracket
Necessary Qty	LM-80	2 pcs	1 pcs	2 pcs	1 pcs	2 pcs	–
	LM-80G	2 pcs	t 1mm:15 pcs t 0.5mm:1 pcs	1 pcs	–	–	2 pcs

No.	15	16	17	18
Name	Hanger Bolt	Nut	Bottom Guide	Hanging Bracket
Necessary Qty	LM-80	–	–	–
	LM-80G	2 pcs	2 pcs	1 pcs

Optional Parts			
No.	19	20	21
Name	Door Stopper	Bracket Cover for Glass	End Cap Set for Glass
Qty / Set	1 pcs	1 pcs	1 set

■ Part Overview

LM-80

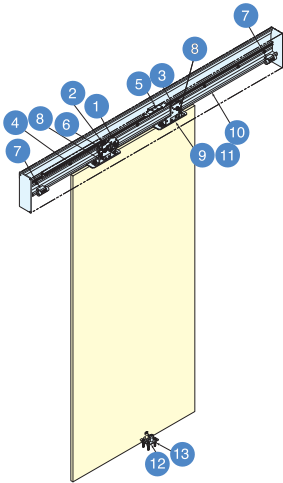

LM-80G

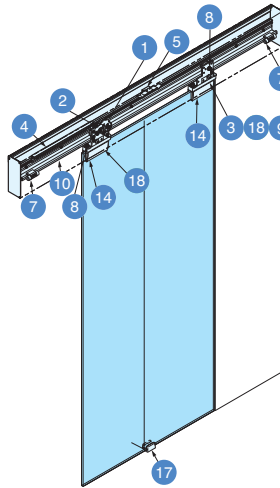

■ Speed Adjustment

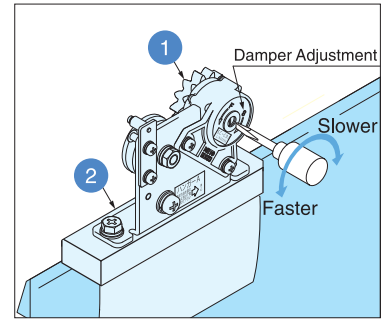

Closing speed adjustable by turning adjustment screw on damper.

LM-80

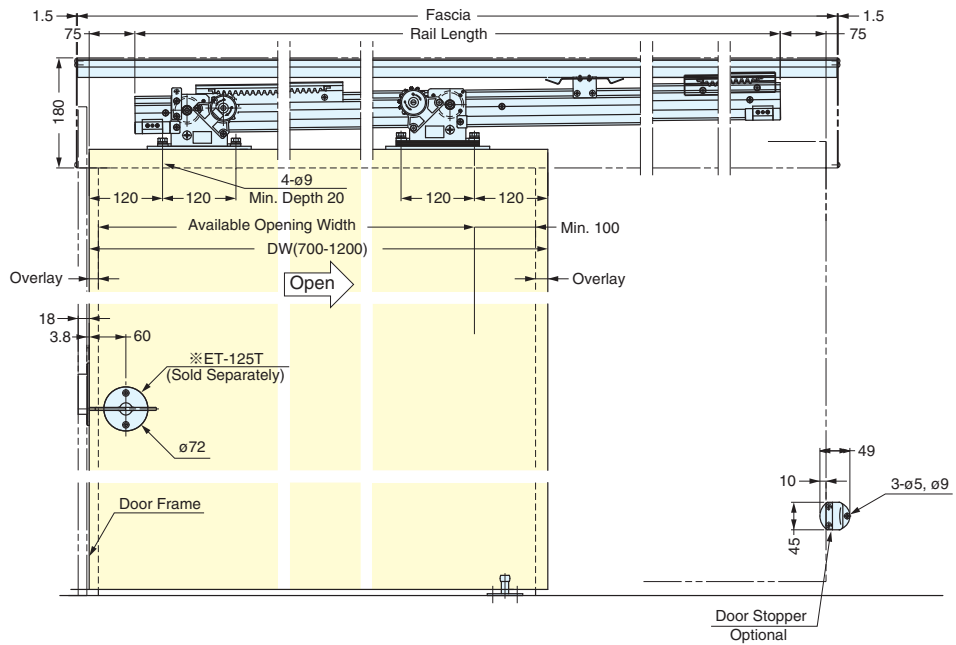
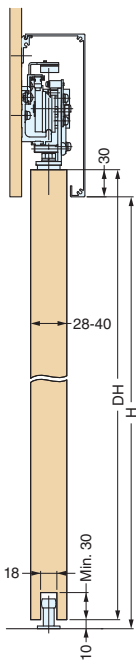

LM-80G

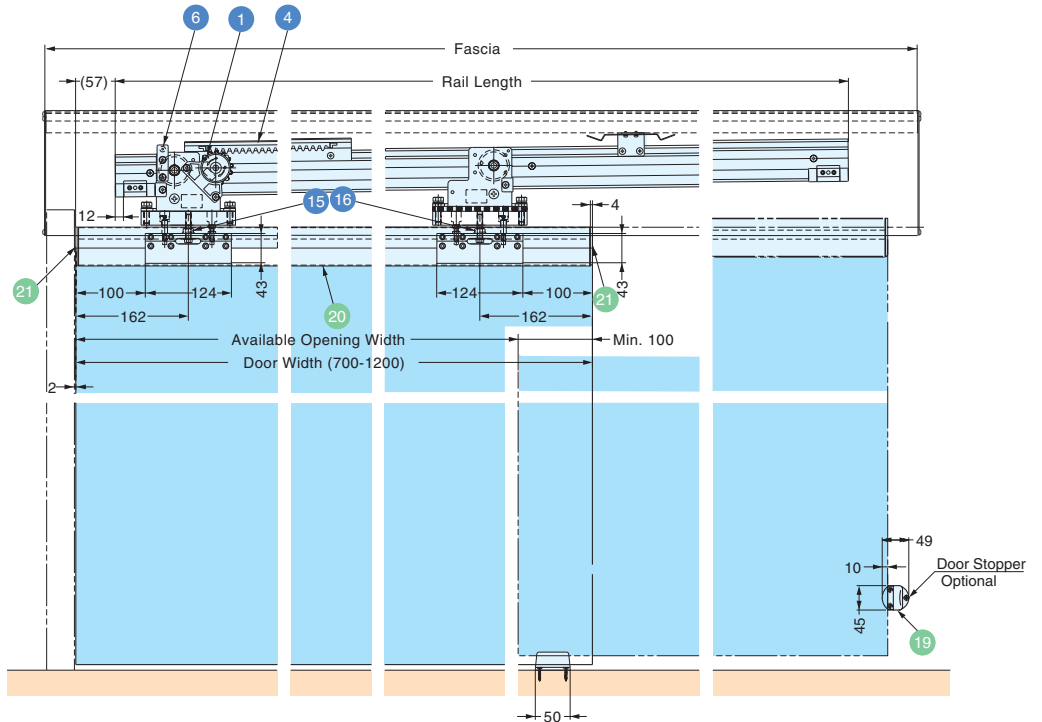
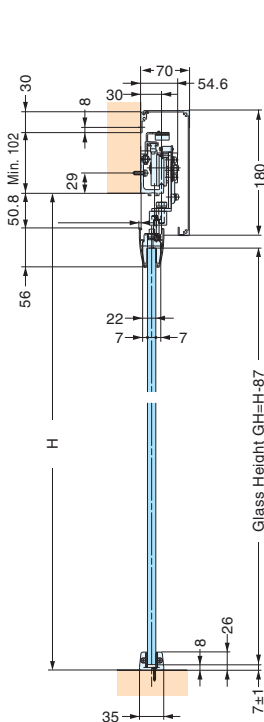

# FOLDING DOOR SYSTEM

# FD30-F



	a	b	c	d
Item Code	250-017-905	250-017-908	250-018-312	250-018-316
Item No.	FD30FKP	FD30UKP	FD30URP	FD30UMP
Application				
	Standard Folding (One pivot fixed)	Standard Folding (One pivot fixed)	Slidable (For partition use)	Slidable (For cabinet use)
Door Width	Max. 450mm			
Door Height	Max. 2400mm			
Door Thickness	Min. 30mm			
Door Weight	Max. 15kg per door			

Parts Set (Per 2 doors)	Necessary Parts		
	Please refer to "Qty a - d" for parts included in each set.		
	Item Code	Item No.	Description
a	250-017-905	FD30FKP	Pivoted folding, center hinge (Surface mount)
b	250-017-908	FD30UKP	Pivoted folding, center hinge (Surface mount)
c	250-018-312	FD30URP	Slidable folding, center hinge (Door edge recessed mount)
d	250-018-316	FD30UMP	Slidable folding, center hinge (Back side recessed mount)

**Parts Included**

No.	Qty				Item Code	Description
	a	b	c	d		
1	1 pcs	-	-	-	250-017-162	Upper Pivot  FD30-FTP • Material Steel / Polyamide • Finish Chromate / White
2	1 pcs	-	-	-	250-017-140	Guide Roller  FD30-FGRU • Material Steel / Polyamide • Finish Chromate / White, Black
3	-	2 pcs	2 pcs	-	250-017-135	Upper Roller (Recessed Mount)  FD30-WRH • Material Zinc Alloy Polyacetal • Finish Chromate / Light Brown
4	-	-	-	2 pcs	250-017-142	Upper Roller (Side Mount)  FD30-WRU • Material Steel / Polyacetal • Finish Chromate / Brown
5	-	1 pcs	-	-	250-017-139	Stopper Block  FD30-HSB • Material Polyacetal • Finish Dark Brown
6	1 pcs	1 pcs	-	-	250-017-163	Bottom Pin  FD30-FBP • Material Steel / Polyacetal • Finish Chromate / White
7	-	-	2 pcs	2 pcs	250-017-164	Guide Pin  FD30-FGR • Material Steel / Polyacetal • Finish Chromate / White
8	1 pcs	1 pcs	1 pcs	1 pcs	250-017-169	Pin Insert Jig FD30-FSJ -
9	1 pcs	1 pcs	-	-	250-017-168	Spanner Wrench FD30-FSP -

No.	Qty				Item Code	Description
	a	b	c	d		
10	-	-	-	-	250-017-165	Top Bracket  FD30-FSK • Material Steel • Finish Chromate
11	1 pcs	-	-	-	250-017-141	Pivot Bracket (Upper)  FD30-FSKU • Material Steel • Finish Chromate
12	1 pcs	1 pcs	-	-	250-017-170	Pivot Bracket (Bottom)  FD30-FPU • Material Steel • Finish Chromate
13	-	1 pcs	-	-	250-017-144	Fixing Plate  FD30-FKK • Material Steel • Finish Chromate
14	-	-	2 pcs	2 pcs	250-017-143	Upper Stopper  FD30-FTST • Material Steel / Polyacetal • Finish Chromate / Brown
15	-	-	-	-	250-019-297	Upper Stopper  FD30-FTST-GR • Material Steel / Polyacetal • Finish Chromate / Grey
16	-	-	2 pcs	2 pcs	250-017-166	Bottom Stopper  FD30-FBKS • Material Steel / Polyacetal • Finish Chromate / Brown
17	-	-	-	-	250-017-146	Center Hinge (Surface Mount, Angle adjustable)  FD30-CHM • Material Steel • Finish Chromate / Black
18	3 pcs	3 pcs	-	-	250-019-899	Center Hinge (Surface Mount, Angle adjustable)  FD30-CHM-WT • Material Steel • Finish Chromate / White
19	-	-	-	3 pcs	250-017-147	Center Hinge (Recessed Mount, Angle adjustable, W/Detent Stop)  FD30-CHH • Material Steel • Finish Black
20	-	-	-	-	250-019-900	Center Hinge (Recessed Mount, Angle adjustable, W/Detent Stop)  FD30-CHH-WT • Material Steel • Finish White
21	-	-	-	3 pcs	250-017-167	Center Hinge (Door Edge, Angle adjustable, W/Detent Stop)  FD30-CHK • Material Zinc Alloy • Finish Dark Brown
22	-	-	-	-	250-019-901	Center Hinge (Door Edge, Angle adjustable, W/Detent Stop)  FD30-CHK-WT • Material Zinc Alloy • Finish White



Upper Track					Necessary Parts						
No.	Mounting	Length	Item Code	Dimensions	Material / Finish	No.	Mounting	Length	Item Code	Dimensions	Material / Finish
23	Surface Mount	910mm	250-017-962		<ul style="list-style-type: none"> <li>Material Aluminum</li> <li>Finish Anodized Silver</li> </ul>	31	Floor Surface Mount	910mm	250-018-080		<ul style="list-style-type: none"> <li>Material Aluminum</li> <li>Finish Anodized Silver</li> </ul>
			FD30-TRM910SIL						FD30-FBRM910SIL		
		1820mm	250-017-131					250-017-160			
			FD30-TRM1820SIL					FD30-FBRM1820SIL			
2730mm	250-017-966	250-018-082									
	FD30-TRM2730SIL	FD30-FBRM2730SIL									
3640mm	250-017-970	250-018-084									
	FD30-TRM3640SIL	FD30-FBRM3640SIL									
27	Recessed Mount	910mm	250-017-964		<ul style="list-style-type: none"> <li>Material Aluminum</li> <li>Finish Anodized Silver</li> </ul>	35	Floor Recessed Mount	910mm	250-018-074		<ul style="list-style-type: none"> <li>Material Aluminum</li> <li>Finish Anodized Silver</li> </ul>
			FD30-TRH910SIL						FD30-FBRH910SIL		
		1820mm	250-017-133					250-017-158			
			FD30-TRH1820SIL					FD30-FBRH1820SIL			
2730mm	250-017-968	250-018-076									
	FD30-TRH2730SIL	FD30-FBRH2730SIL									
3640mm	250-017-972	205-018-078									
	FD30-TRH3640SIL	FD30-FBRH3640SIL									

Cover Cap		Necessary Parts for					
No.	Item Code	Specification	Installation	Description			
39	250-018-785	Cover Cap for Upper Roller			<ul style="list-style-type: none"> <li>Material Polypropylene</li> <li>Finish White</li> </ul>		
	FD30-WRH-CP-WT						
40	250-017-138					FD30-WRH-CP	<ul style="list-style-type: none"> <li>Material Polypropylene</li> <li>Finish Light Brown</li> </ul>
	41						
End Cap (For Roller③)							

Optional Parts					
No.	Item Code	Specification	Installation	Description	
42	250-017-171	Prevents door racking when door is closed, especially in double doors			<ul style="list-style-type: none"> <li>Material Polycarbonate Neodymium</li> <li>Finish Dark Brown</li> </ul>
	FD30-FMF				
43	250-017-173	Prevents door racking when door is closed, especially in double doors			<ul style="list-style-type: none"> <li>Material Polyamide / Steel</li> <li>Finish White / Chromate</li> </ul>
	FD30-FTF				
44	250-017-172	To hold the door close in [d] configuration, to be installed on bottom guide track			<ul style="list-style-type: none"> <li>Material Polyacetal</li> <li>Finish Dark Brown</li> </ul>
	FD30-FHL				

Center Hinge - Details					
No.	Item Code	Installation	Angle Adjustment	Detent	
17	250-017-146		Surface Mount		37° angle
	FD30-CHM				
18	250-019-899		Back Side Recessed Mount		50° angle
	FD30-CHM-WT				
19	250-017-147		Door Edge Recessed Mount		47° angle
	FD30-CHH				
20	250-019-900		Door Edge Recessed Mount		47° angle
	FD30-CHH-WT				
21	250-017-167		Door Edge Recessed Mount		47° angle
	FD30-CHK				
22	250-019-901		Door Edge Recessed Mount		47° angle
	FD30-CHK-WT				

**a** Pivoted Folding, Center Hinge - Surface Mount

• Center Hinge has angle adjustment, detent stop feature and mounted on surface at back side of door for easy installation.

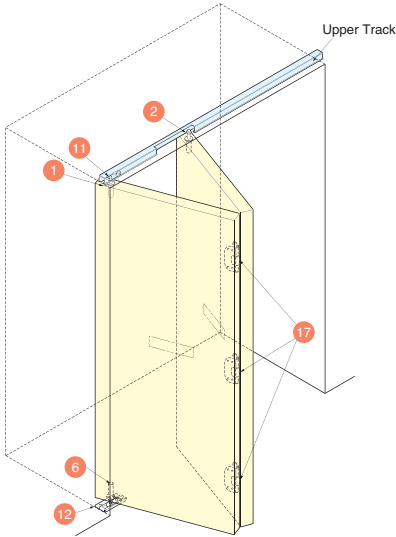

■ Door Preparation

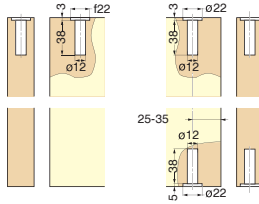

■ Installation Example  
(In case of 40mm thick, 450mm wide door)

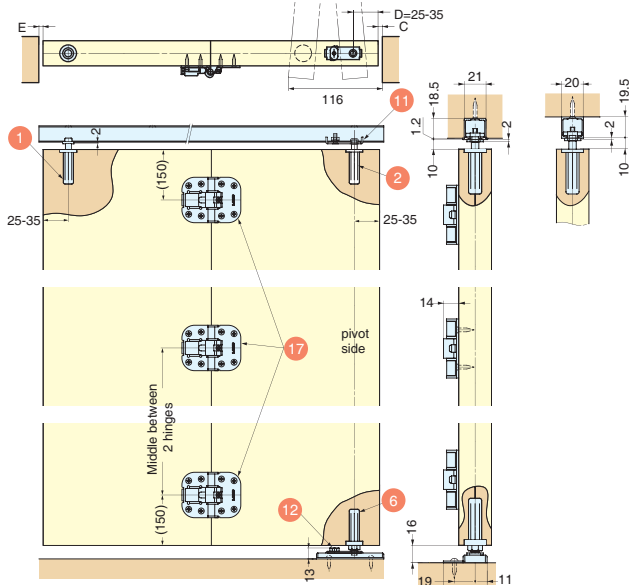

■ Gap - Door and Frame

Door Thickness	C=Gap (D=30)	Gap total : C + E			
		Width 300	Width 350	Width 400	Width 450
30	4.0	7.5	7.0	6.7	6.4
35	5.2	9.5	8.9	8.5	8.2
40	6.5	11.7	11.0	10.5	10.1

**b** Pivoted Folding, Center Hinge - Surface Mount

• Center Hinge has angle adjustment, detent stop feature and mounted on surface at back side of door for easy installation.

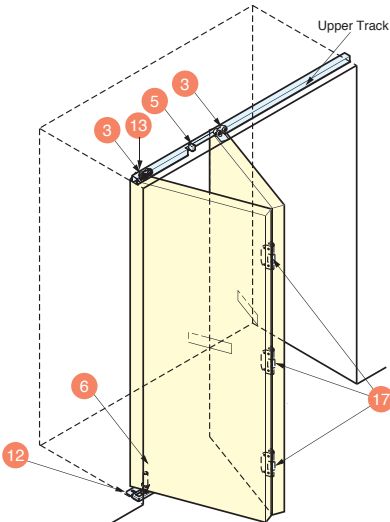

■ Door Preparation

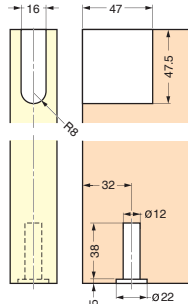

■ Installation Example  
(In case of 40mm thick, 450mm wide door)

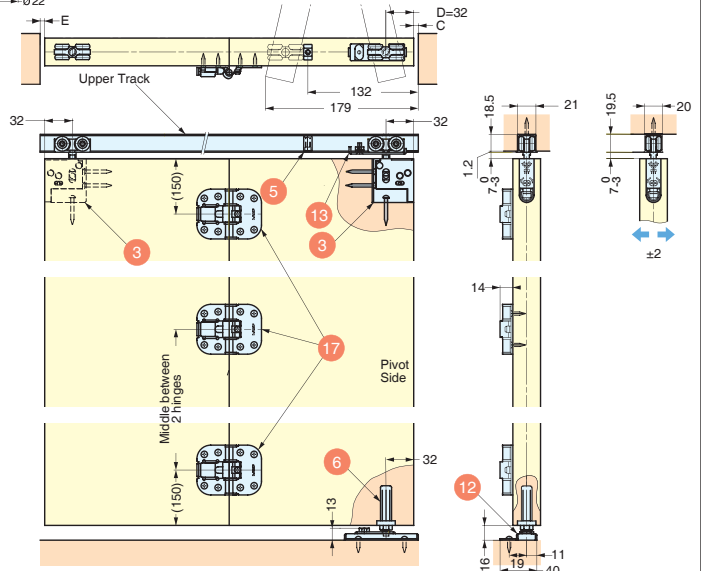

■ Gap - Door and Frame

Door Thickness	C=Gap (D=30)	Gap total : C + E			
		Width 300	Width 350	Width 400	Width 450
30	4.0	7.5	7.0	6.7	6.4
35	5.2	9.5	8.9	8.5	8.2
40	6.5	11.7	11.0	10.5	10.1

**c** Slidable Folding, Center Hinge – Door Edge Recessed Mount

- Center Hinge has angle adjustment, detent stop feature and mounted in recess at door edge which is invisible from both side.
- Detent center hinge allows the folding door to slide freely for easy access and to maximize the space.

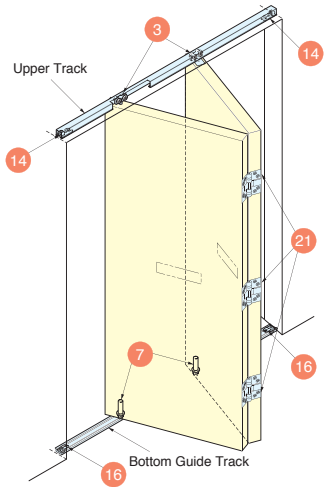

■ Door Preparation

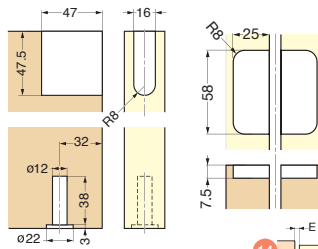

■ Installation Example  
(In case of 40mm thick, 450mm wide door)

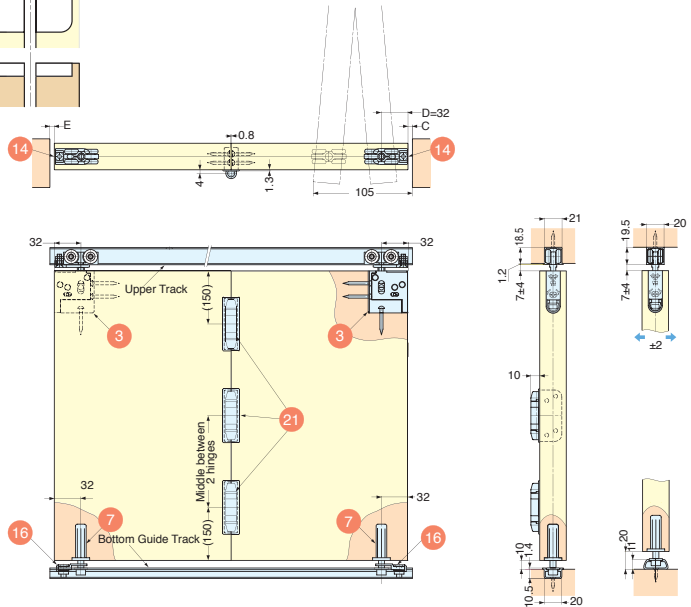

■ Gap - Door and Frame

Door Thickness	C=Gap (D=30)	Gap total : C + E			
		Width 300	Width 350	Width 400	Width 450
30	4.0	7.5	7.0	6.7	6.4
35	5.2	9.5	8.9	8.5	8.2
40	6.5	11.7	11.0	10.5	10.1

**d** Slidable Folding, Center Hinge – Back Side Recessed Mount

- Center Hinge has angle adjustment, detent stop feature and mounted in recess at back side of door.
- Detent center hinge allows the folding door to slide freely for easy access and to maximize the space.

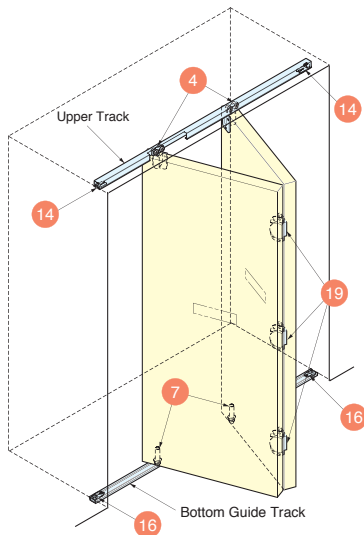

■ Installation Example  
(In case of 40mm thick, 450mm wide door)

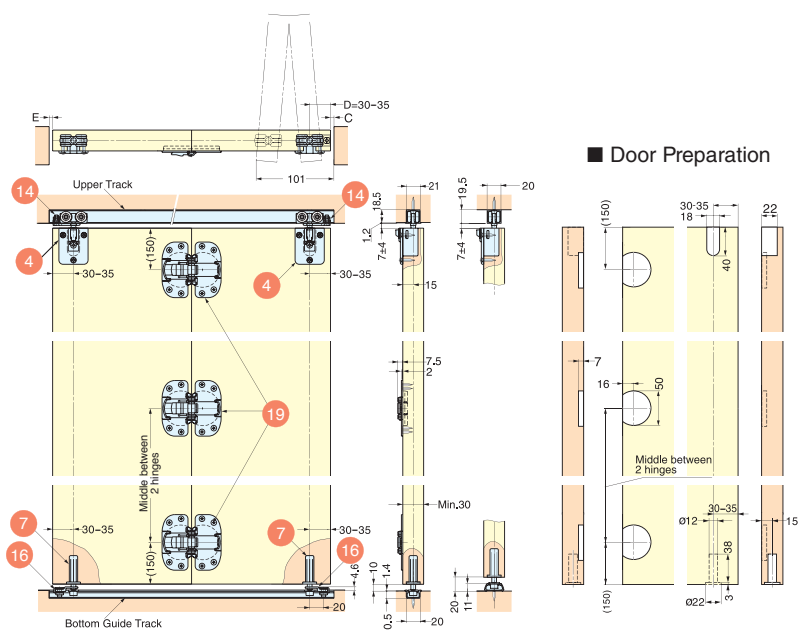

■ Door Preparation

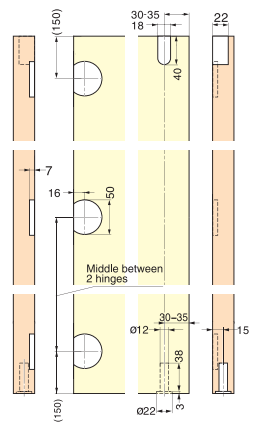

■ Gap - Door and Frame

Door Thickness	C=Gap (D=30)	Gap total : C + E			
		Width 300	Width 350	Width 400	Width 450
30	3.6	6.0	5.7	5.5	5.3
35	5.8	8.8	8.4	8.1	7.9
40	8.5	12.0	11.6	11.2	11.0

# STACKABLE PARTITION DOOR SYSTEM

## FDP40P

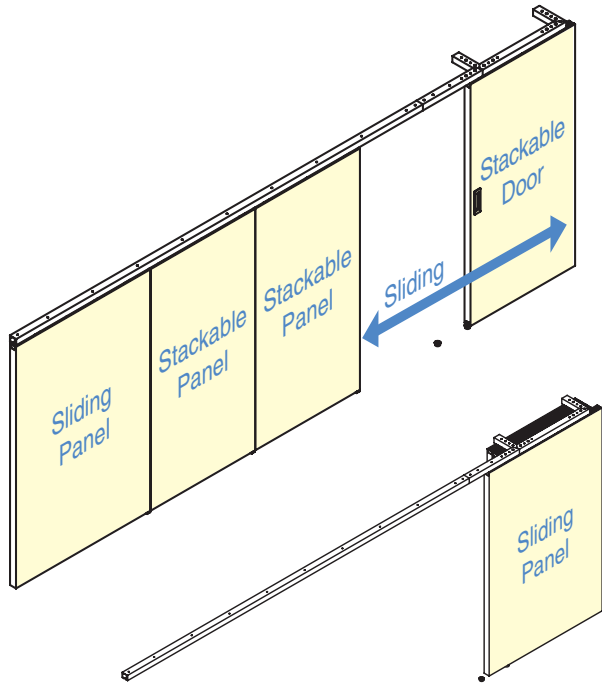

■ Door Preparation

Type	FDP40P
Roller	Parallel Stacking
Door Weight	Max. 40kg per door
Door Thickness	34-40mm
Door Width	700-1000mm (Stackable Door/Panel)
	700-1300mm (Sliding Panel)
Door Height	Max. 2500mm

- Parallel stacking partition door system.
- Easy door installation - Simply hang the door onto the rollers.
- No bottom rail, clean appearance.

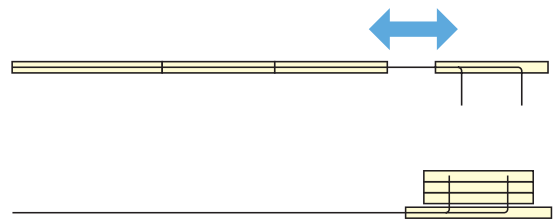

Stackable Door(SD)

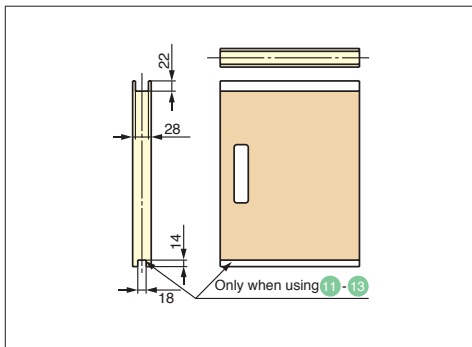

Stackable Panel(SP) / Sliding Panel(CP)

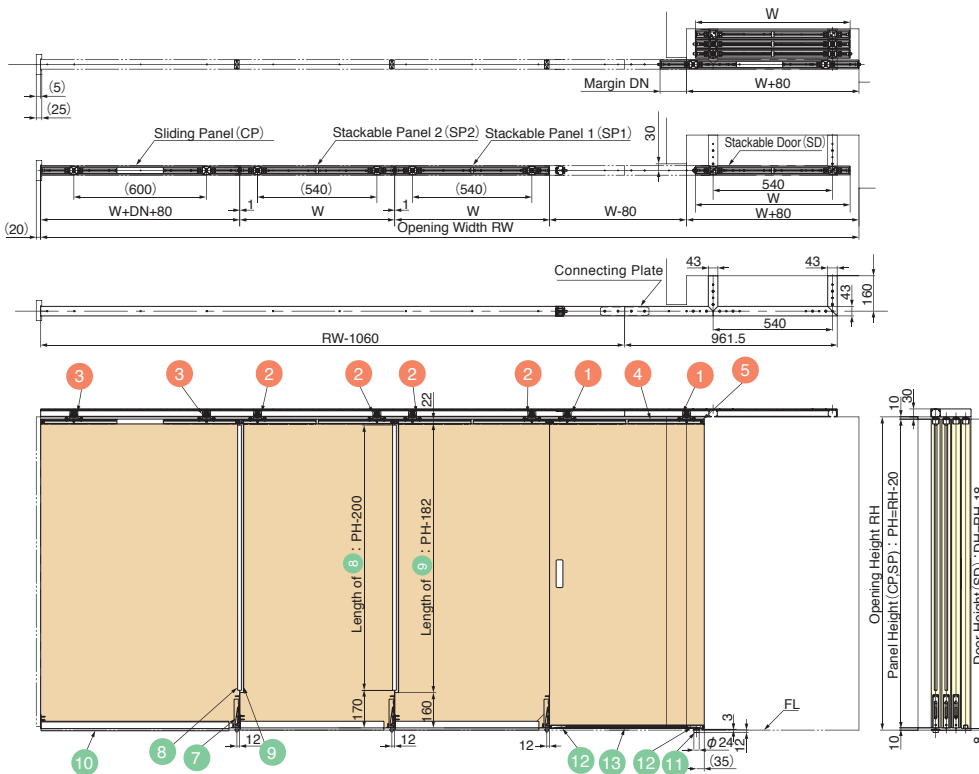
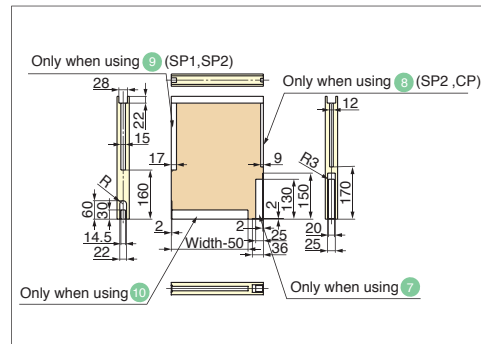

Parts Set		Necessary Parts	
Please refer to "Qty a - b" for parts included in each set.			
	Item Code	Item No.	Description
a	250-024-540	FDP40P3P	3Doors
b	250-024-541	FDP40P4P	4Doors

**Parts Included**

No.	Qty		Item Code	Description
	a	b		
1	1 set	1 set	250-024-501	<ul style="list-style-type: none"> <li>Material Zinc Alloy / Polyacetal</li> <li>Finish Nickel / Natural</li> </ul> FDP40P-QRF-ST
			Recessed Roller For Stackable Door (SD)	
2	1 set	2 sets	250-024-502	<ul style="list-style-type: none"> <li>Material Zinc Alloy / Polyacetal</li> <li>Finish Nickel / Natural</li> </ul> FDP40P-QRF
			Recessed Roller For Stackable Panel (SP)	
3	1 set	1 set	250-024-503	<ul style="list-style-type: none"> <li>Material Zinc Alloy / Polyacetal</li> <li>Finish Nickel / Natural</li> </ul> FDP40P-QRL
			Recessed Roller For Sliding Panel (CP)	
4	3 sets	4 sets	250-024-505	<ul style="list-style-type: none"> <li>Material Aluminum</li> <li>Finish Anodized Silver</li> </ul> FDP40-DTR340
			Hanging Bracket	
5	6 pcs	8 pcs	250-121-142	<ul style="list-style-type: none"> <li>Material Elastmer(TPE)</li> <li>Finish Black</li> </ul> FD-70B-EC
			End Cap	
6	1 pcs	1 pcs	250-024-506	<ul style="list-style-type: none"> <li>Material Steel</li> <li>Finish Nickel / Natural</li> </ul> FDP40-SP10
			Spanner For Adjustment	

Optional Parts			
No.	Item Code	Description	
7	250-024-525	<ul style="list-style-type: none"> <li>Material SUS304</li> <li>Finish Satin</li> </ul> FDP40-DBL150HL	
	Flush Bolt		
8	250-024-526	<ul style="list-style-type: none"> <li>Material Rubber (CR)</li> <li>Finish Black</li> </ul> FDP40-DSP2500BL	
	Gasket		
9	250-024-527	<ul style="list-style-type: none"> <li>Material ABS</li> <li>Finish Black</li> </ul> FDP40-DSPU2500BL	
	Counter Part For Gasket		
10	250-024-528	<ul style="list-style-type: none"> <li>Material Aluminum</li> <li>Finish Anodized Silver</li> </ul> FDP40-DBT800	
	Door Bottom Tightener (W: 800mm)		
11	250-024-529	<ul style="list-style-type: none"> <li>Material Aluminum</li> <li>Finish Anodized Silver</li> </ul> FDP40-DBT1000	
	Door Bottom Tightener (W: 1000mm)		
12	250-024-530	<ul style="list-style-type: none"> <li>Material Steel / ABS</li> <li>Finish Ivoly</li> </ul> FDP40-GPS1-BE	
	Magnetic Floor Guide (Ivoly)		
13	250-024-531	<ul style="list-style-type: none"> <li>Material Steel / ABS</li> <li>Finish Dark Brown</li> </ul> FDP40-GPS1-DBE	
	Magnetic Floor Guide (Dark Brown)		
14	250-024-532	<ul style="list-style-type: none"> <li>Material Neodymium / Polyamide</li> <li>Finish Nickel / Brown</li> </ul> FDP40-GPM2	
	Counter Plate For Magnetic Floor Guide		
15	250-024-533	<ul style="list-style-type: none"> <li>Material ABS</li> <li>Finish Natural</li> </ul> FDP40-GPR1	
	Guide Track For		

Upper Track		Necessary Parts	
Item Code	Description	Item Code	Description
250-024-507	FDP40-TRM3000SL	250-024-513	FDP40P-TRMSL-SL
Upper Track (3000mm)			
250-024-508	FDP40-TRM4000SL	250-024-514	FDP40P-TRMSR-SL
Upper Track (4000mm)			

# STACKABLE PARTITION DOOR SYSTEM

# FDP40V

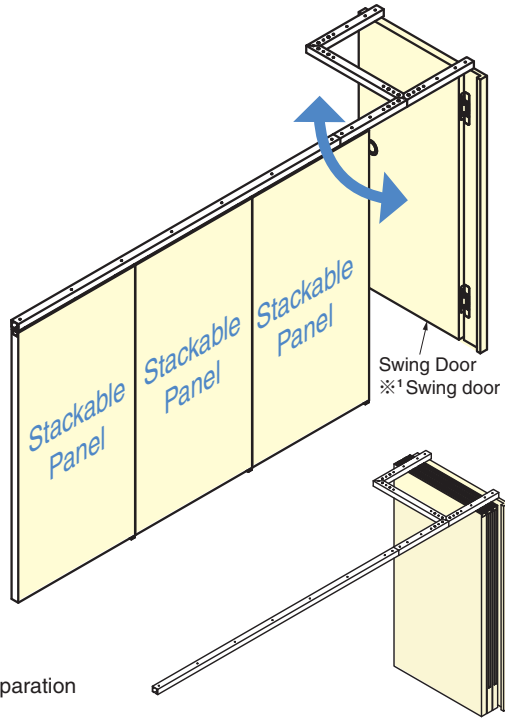

Type	FDP40V
Roller	Column Stacking
Door Weight	Max. 40kg per door
Door Thickness	34-40mm
Door Width	Max. 900mm (Swing Door)
	700-900mm (Stackable Panel)
Door Height	Max. 2500mm

- Column stacking partition door system.
- Easy door installation - Simply hang the door onto the rollers.
- No bottom rail, clean appearance.
- Swing door parts are optional.

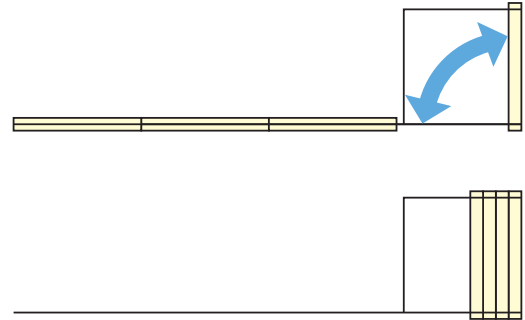

### ■ Door Preparation

#### Stackable Panel(SP)

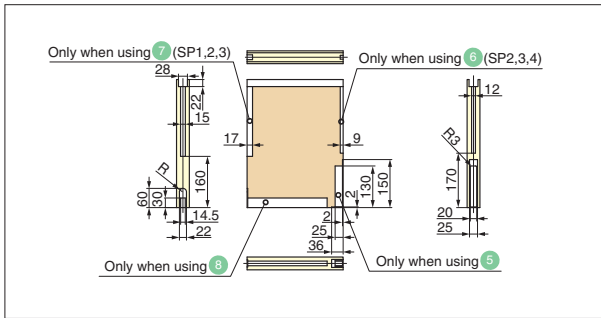

#### For Door Stopper 11 (SD)

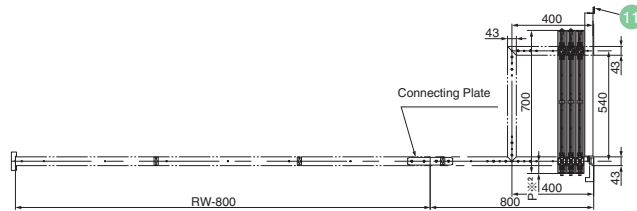
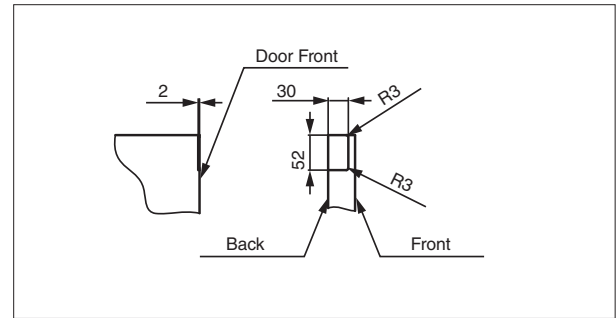

※2  
If panel width PW ≤ 780, then P = 60.  
If 780 < panel width PW ≤ 900,  
then P ≥ panel width PW - 720.

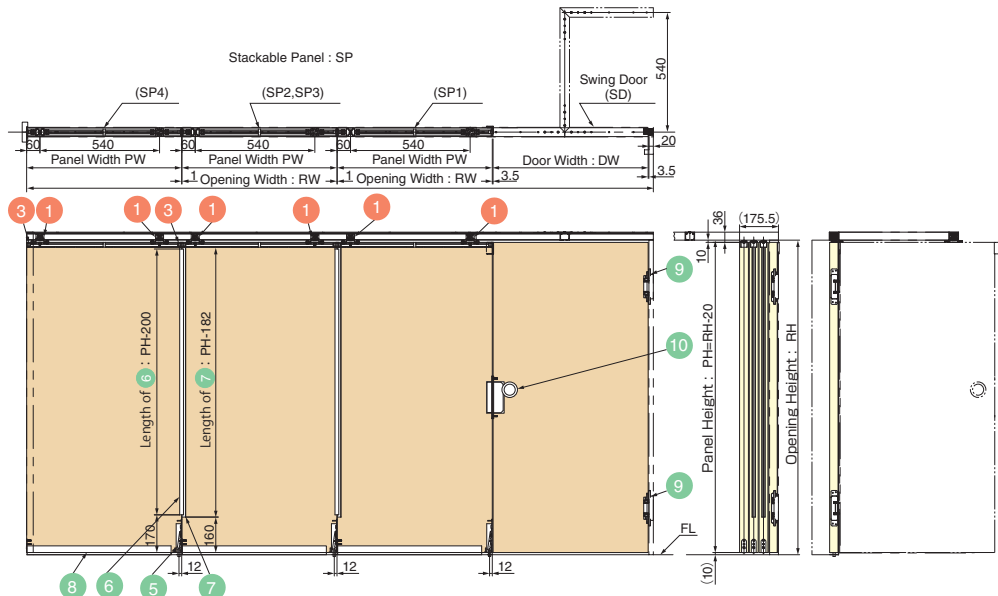

Parts Set		Necessary Parts	
Please refer to "Qty [a] - [b]" for parts included in each set.			
	Item Code	Item No.	Description
[a]	250-024-542	FDP40V3P	3Doors
[b]	250-024-543	FDP40V4P	4Doors

## Parts Included

No.	Qty		Item Code	Description
	[a]	[b]		
1	3 sets	4 sets	250-024-504	<ul style="list-style-type: none"> <li>Material Zinc Alloy / Polyacetal</li> <li>Finish Nickel / Natural</li> </ul>
			FDP40V-QR	
2	3 sets	4 sets	250-024-505	<ul style="list-style-type: none"> <li>Material Aluminum</li> <li>Finish Anodized Silver</li> </ul>
			FDP40-DTR340	
3	6 pcs	8 pcs	250-121-142	<ul style="list-style-type: none"> <li>Material Elastmer(TPE)</li> <li>Finish Black</li> </ul>
			FD-70B-EC	
4	1 pcs	1 pcs	250-024-506	<ul style="list-style-type: none"> <li>Material Steel</li> <li>Finish Nickel / Natural</li> </ul>
			FDP40-SP10	

Optional Parts		
No.	Item Code	Description
5	250-024-525	<ul style="list-style-type: none"> <li>Material SUS304</li> <li>Finish Satin</li> </ul>
	FDP40-DBL150HL	
6	250-024-526	<ul style="list-style-type: none"> <li>Material Rubber (CR)</li> <li>Finish Black</li> </ul>
	FDP40-DSP2500BL	
7	250-024-527	<ul style="list-style-type: none"> <li>Material ABS</li> <li>Finish Black</li> </ul>
	FDP40-DSPU2500BL	
8	250-024-528	<ul style="list-style-type: none"> <li>Material Aluminum</li> <li>Finish Anodized Silver</li> </ul>
	FDP40-DBT800	
8	250-024-529	<ul style="list-style-type: none"> <li>Material Aluminum</li> <li>Finish Anodized Silver</li> </ul>
	FDP40-DBT1000	
9	170-020-804	<ul style="list-style-type: none"> <li>Material Steel / Polyacetal</li> <li>Finish Nickel / Light Grey</li> </ul>
	Hinge	
10	250-024-534	<ul style="list-style-type: none"> <li>Material Zinc Alloy / Stainless Steel</li> <li>Finish Satin Nickel</li> </ul>
	MLH	
11	250-024-535	<ul style="list-style-type: none"> <li>Material Stainless Steel / Plastic (PUR)</li> <li>Finish Polished</li> </ul>
	Door Stopper	
	FDP40V-DSTS	

Upper Track		Necessary Parts	
Item Code	Description	Item Code	Description
250-024-507	<ul style="list-style-type: none"> <li>Material Aluminum</li> <li>Finish Anodized Silver</li> </ul>	250-024-519	<ul style="list-style-type: none"> <li>Material Aluminum</li> <li>Finish Anodized Silver</li> </ul>
Upper Track (3000mm)		FDP40V-TRMSL-SL	
250-024-508	<ul style="list-style-type: none"> <li>Material Aluminum</li> <li>Finish Anodized Silver</li> </ul>	250-024-520	<ul style="list-style-type: none"> <li>Material Aluminum</li> <li>Finish Anodized Silver</li> </ul>
Upper Track (4000mm)		FDP40V-TRMSR-SL	

# LAPCON DOOR DAMPER (RECESSED TYPE)



LDD-V



- Door damper unit for interior, swinging doors.
- Grips door at final 10° and softly, self-closes doors more gently compared to other door closers, putting less stress on the hinges.
- "Invisible" design minimizes visibility of the hardware.
- Recommended Door Specifications:  
 Thickness: minimum 33mm  
 Width: maximum 900mm  
 Weight: 15-40kg
- Can be adjusted for door weight after installation. Counterplate position can be easily adjusted by removing cover and turning micro-adjustment screws.
- Can be used with HES hinges, sold separately.
- Includes screws and paper template for installation.

LDD-V-R is shown

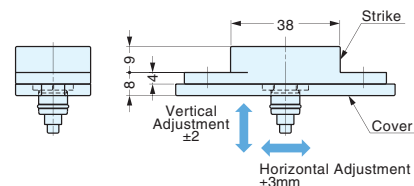
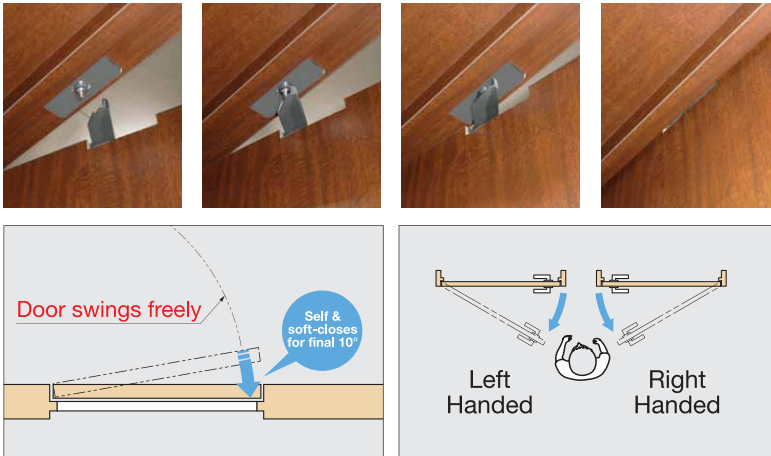

LDD-V-R is shown

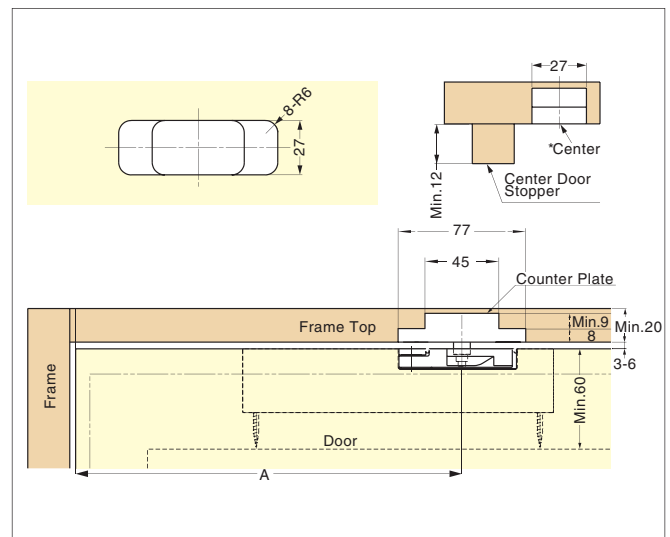
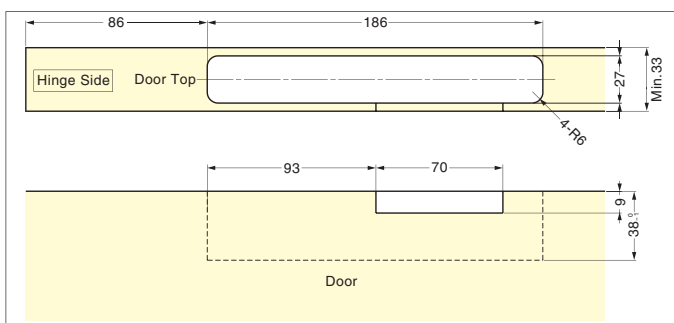
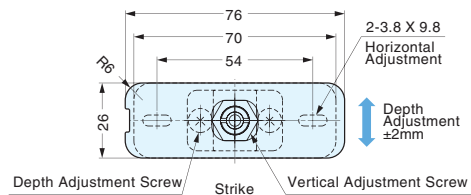
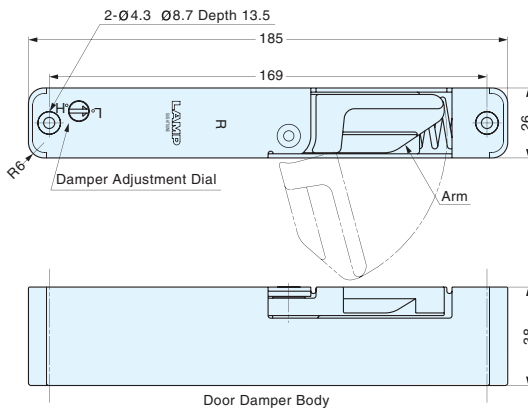

Bore Dimensions (Door)

Bore Dimensions (Frame)

Hinge	A
HES3D-120	219
HES3D-160,190	220
Butt Hinge	223

Item code	Item No.	Type	Box	Carton
270-017-563	LDD-V-R	Right	1pcs	24pcs
270-017-564	LDD-V-L	Left	1pcs	24pcs

Part Name	Material	Finish/Color
Main Body	Steel/Polyacetal/PBT	Chromate/Grey
Counter Plate	Steel/Polyacetal	Nickel/Grey



# LAPCON DOOR DAMPER (SURFACE MOUNT TYPE)



LDD-S

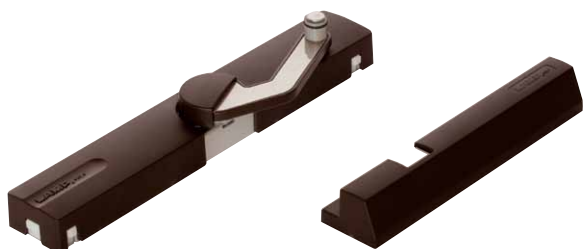

LDD-S-R DBR  
(Right - handed)

- Door damper unit for interior, swinging doors.
- Grips door at final 15° and softly, self-closes doors more gently compared to other door closers, putting less stress on the hinges.
- Surface mounting allows hardware to be added to existing doors.
- Recommended Door Specifications:  
Width: Max. 900mm  
Weight: 15-40kg
- Can be adjusted for door weight after installation. Damper function can also be switched off.
- Slim, unobtrusive design: damper unit is just 20mm high, easily fitting most door frames.
- Available in 4 colors to match your door, specify White (WT), Light Grey (LGR), Light Brown (LBR), or Dark Brown (DBR).
- Can be used with HES hinges, sold separately.
- Includes screws for installation.
- Spacer, LDD-S-P is available as an option.



■ Available in the following colors:



■ Top View

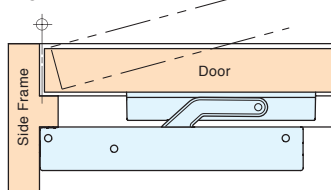

■ Front View

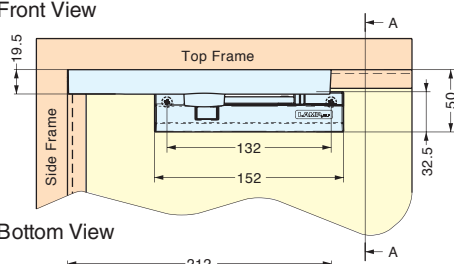

■ Bottom View

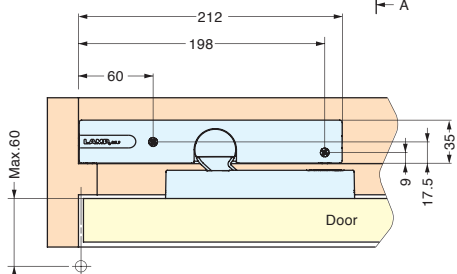

■ Side View

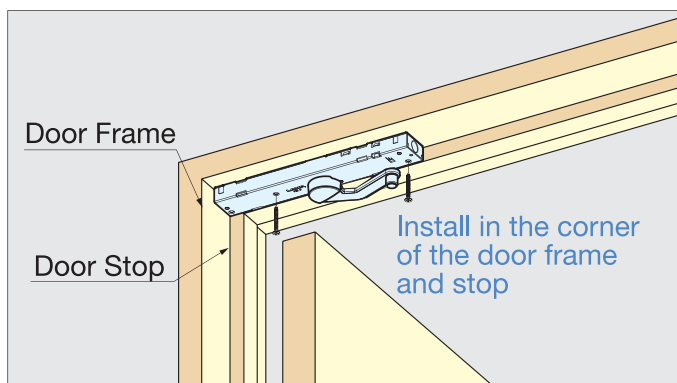
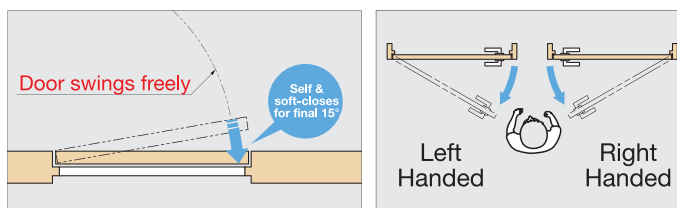
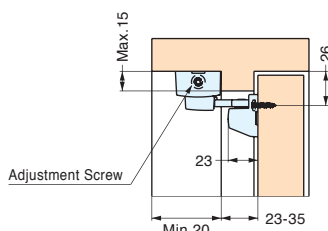

Item Code	Item No.	Color	Type	Door Weight	Door Width	Box	Carton
270-018-984	LDD-S-R WT	White	Right	15-40kg	Max. 900mm	1pcs	20 pcs
270-018-985	LDD-S-L WT	White	Left	15-40kg	Max. 900mm	1pcs	20 pcs
270-018-986	LDD-S-R LGR	Light Grey	Right	15-40kg	Max. 900mm	1pcs	20 pcs
270-018-987	LDD-S-L LGR	Light Grey	Left	15-40kg	Max. 900mm	1pcs	20 pcs
270-018-988	LDD-S-R LBR	Light Brown	Right	15-40kg	Max. 900mm	1pcs	20 pcs
270-018-989	LDD-S-L LBR	Light Brown	Left	15-40kg	Max. 900mm	1pcs	20 pcs
270-018-990	LDD-S-R DBR	Dark Brown	Right	15-40kg	Max. 900mm	1pcs	20 pcs
270-018-991	LDD-S-L DBR	Dark Brown	Left	15-40kg	Max. 900mm	1pcs	20 pcs

Component	Material	Finish/Color
Main Body	Steel, Zinc Alloy	Zinc Plating
Counter Plate	Steel, Zinc Alloy	Zinc Plating
Covers	ABS	See Colors

# LAPCON DOOR DAMPER (RECESSED TYPE)



LDD-V



- Door damper unit for interior, swinging doors.
- Grips door at final 10° and softly, self-closes doors more gently compared to other door closers, putting less stress on the hinges.
- "Invisible" design minimizes visibility of the hardware.
- Recommended Door Specifications:  
Thickness: minimum 33mm  
Width: maximum 900mm  
Weight: 15-40kg
- Can be adjusted for door weight after installation. Counterplate position can be easily adjusted by removing cover and turning micro-adjustment screws.
- Can be used with HES hinges, sold separately.
- Includes screws and paper template for installation.

LDD-V-R is shown

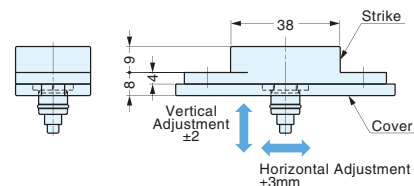
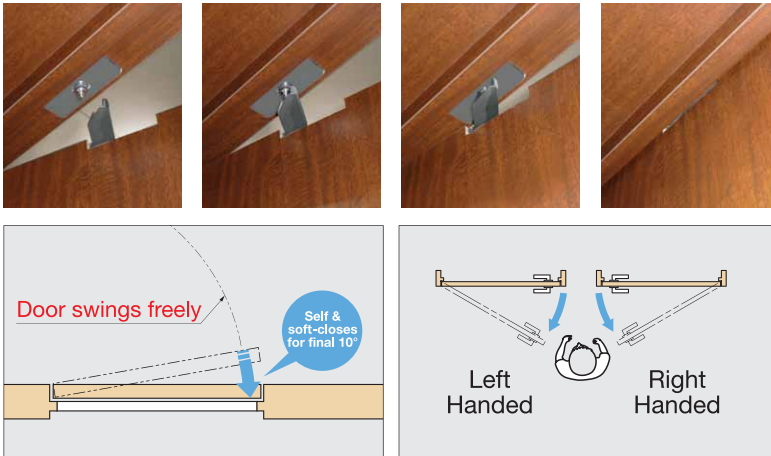

LDD-V-R is shown

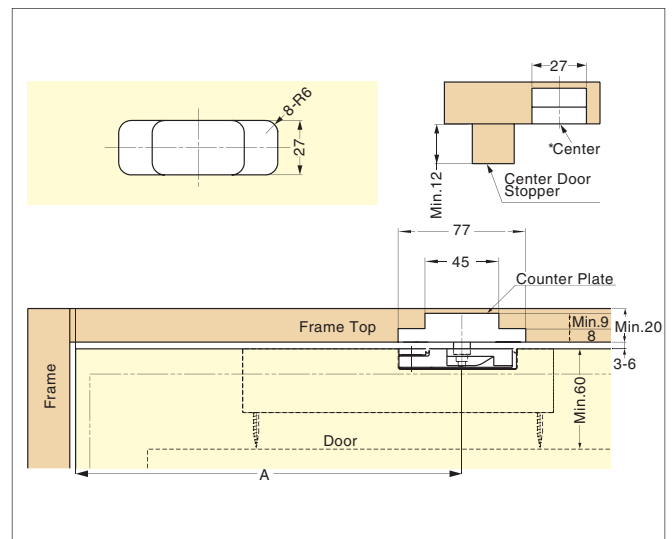
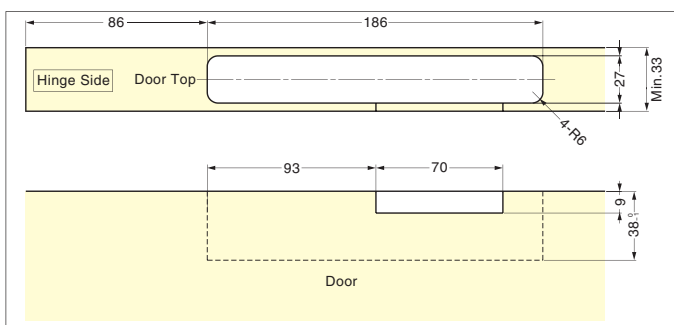
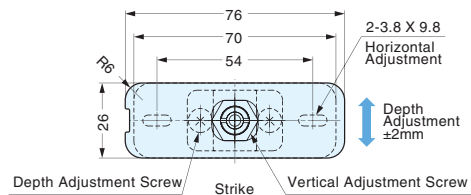
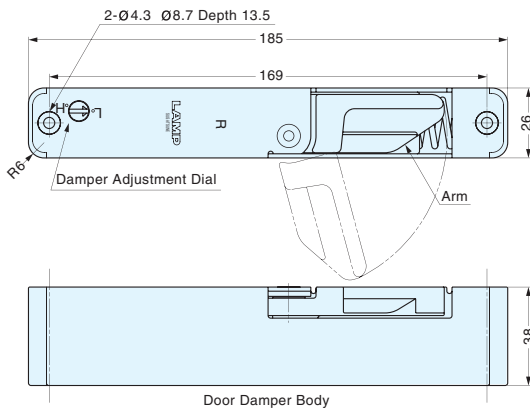

Bore Dimensions (Door)

Bore Dimensions (Frame)

Hinge	A
HES3D-120	219
HES3D-160,190	220
Butt Hinge	223

Item code	Item No.	Type	Box	Carton
270-017-563	LDD-V-R	Right	1pcs	24pcs
270-017-564	LDD-V-L	Left	1pcs	24pcs

Part Name	Material	Finish/Color
Main Body	Steel/Polyacetal/PBT	Chromate/Grey
Counter Plate	Steel/Polyacetal	Nickel/Grey

# LAPCON DOOR DAMPER (SURFACE MOUNT TYPE)



LDD-S

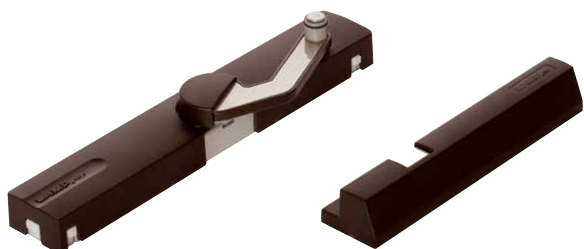

LDD-S-R DBR  
(Right - handed)

- Door damper unit for interior, swinging doors.
- Grips door at final 15° and softly, self-closes doors more gently compared to other door closers, putting less stress on the hinges.
- Surface mounting allows hardware to be added to existing doors.
- Recommended Door Specifications:  
Width: Max. 900mm  
Weight: 15-40kg
- Can be adjusted for door weight after installation. Damper function can also be switched off.
- Slim, unobtrusive design: damper unit is just 20mm high, easily fitting most door frames.
- Available in 4 colors to match your door, specify White (WT), Light Grey (LGR), Light Brown (LBR), or Dark Brown (DBR).
- Can be used with HES hinges, sold separately.
- Includes screws for installation.
- Spacer, LDD-S-P is available as an option.



■ Available in the following colors:



■ Top View

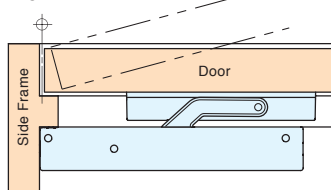

■ Front View

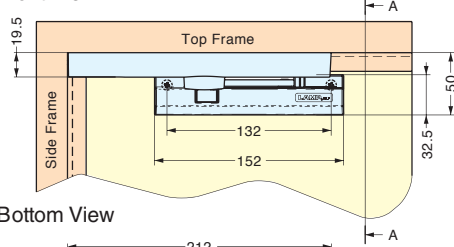

■ Bottom View

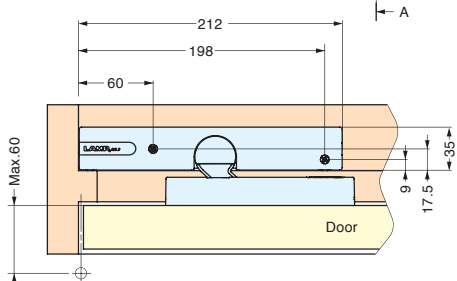

■ Side View

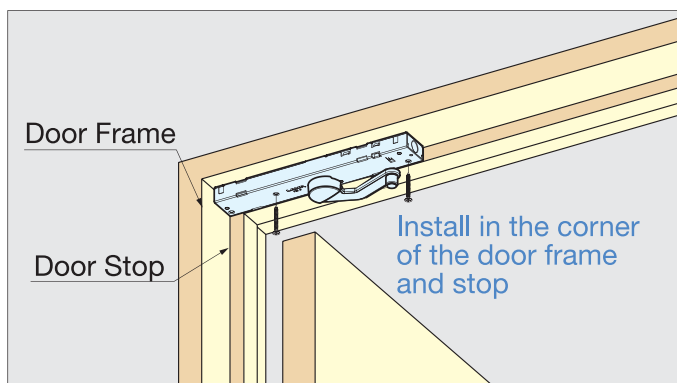
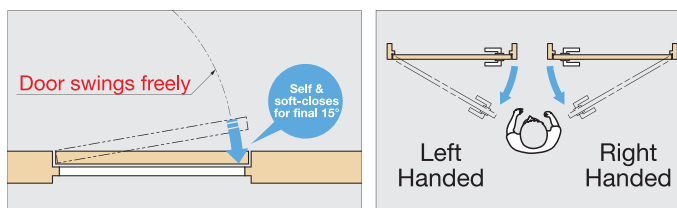
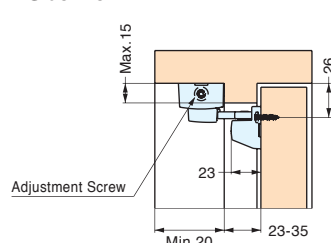

Item Code	Item No.	Color	Type	Door Weight	Door Width	Box	Carton
270-018-984	LDD-S-R WT	White	Right	15-40kg	Max. 900mm	1pcs	20 pcs
270-018-985	LDD-S-L WT	White	Left	15-40kg	Max. 900mm	1pcs	20 pcs
270-018-986	LDD-S-R LGR	Light Grey	Right	15-40kg	Max. 900mm	1pcs	20 pcs
270-018-987	LDD-S-L LGR	Light Grey	Left	15-40kg	Max. 900mm	1pcs	20 pcs
270-018-988	LDD-S-R LBR	Light Brown	Right	15-40kg	Max. 900mm	1pcs	20 pcs
270-018-989	LDD-S-L LBR	Light Brown	Left	15-40kg	Max. 900mm	1pcs	20 pcs
270-018-990	LDD-S-R DBR	Dark Brown	Right	15-40kg	Max. 900mm	1pcs	20 pcs
270-018-991	LDD-S-L DBR	Dark Brown	Left	15-40kg	Max. 900mm	1pcs	20 pcs

Component	Material	Finish/Color
Main Body	Steel, Zinc Alloy	Zinc Plating
Counter Plate	Steel, Zinc Alloy	Zinc Plating
Covers	ABS	See Colors



HES is our complete line of concealed hinges that incorporates a distinct functionality with high load capacity, safety, and adjustability, but most of all...design.

The HES logo expresses our spirit through quality craftsmanship.



Concealed for  
Elegance



Designed for  
Versatility

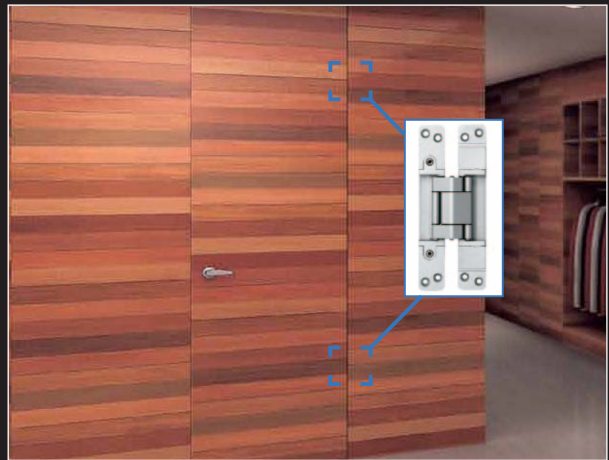

#### a. Detailed View

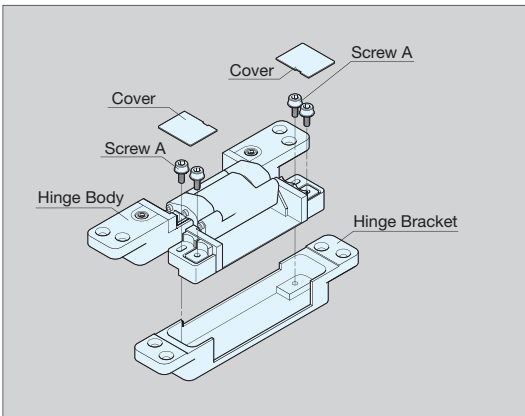

#### For Easy Installation

1. Separate parts as shown in picture "a"
2. Screw on the Hinge Body to door, and Hinge Bracket to door frame.
3. As shown in picture "b", insert Hinge Body straight into Hinge Bracket. Bracket will temporarily hold the Body for easy installation.
4. Use "screw A" to fix Body on Bracket.
5. Adjust horizontally by turning "screw B".
6. Loosen "screw A" for vertical adjustment. Tighten "screw A" after vertical adjustment completed.
7. For depth adjustment, loosen "screw C" (one turn). Tighten "screw C" after completed.
8. Snap on plastic covers after all above completed.

#### b. Installation

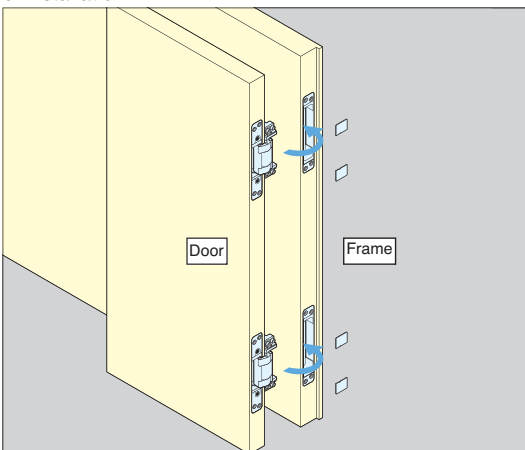

#### c. 3WAY Adjustment

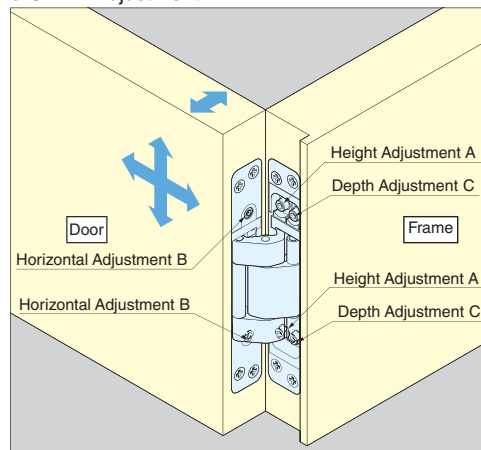

# 3-WAY ADJUSTABLE CONCEALED HINGE



## HES3D-120



HES3D-120DN

HES3D-120DC

- 3 WAY adjustment function allows vertical, horizontal, and depth adjustment after hinge installed.
- Easy installation and adjustment.
- Successfully passed 300,000 open/close private cycle tests.
- Supplied with steel flat head screw.
- Cover hides all screw heads for clean appearance.
- Door weight: Max. 30kg/2pcs, 40kg/3pcs
- Door Thickness: Min. 29mm
- Max. Door Size: H 2400mm x W 900mm

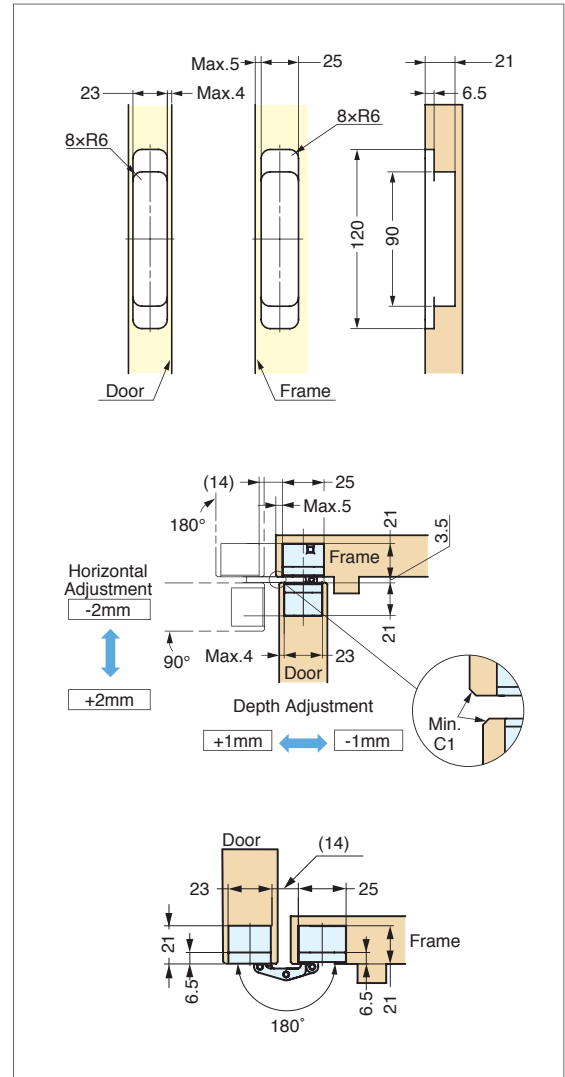
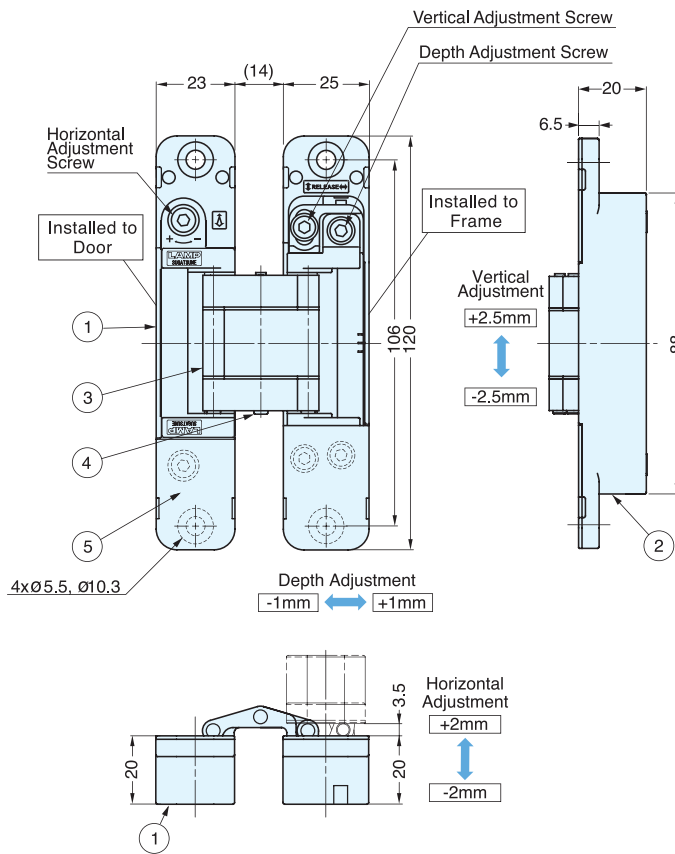

Bore Dimensions

No.	Part Name	Material	Finish/Color
①	Body	Zinc Alloy	Satin Chrome(Silver), Satin Nickel(Champagne Gold)
②	Base Frame	Zinc Alloy	Satin Chrome(Silver), Satin Nickel(Champagne Gold)
③	Arm	Zinc Alloy	Satin Chrome(Silver), Satin Nickel(Champagne Gold)
④	Pin	201 Stainless Steel	-
⑤	Cover	ABS	Satin Chrome(Silver), Satin Nickel(Champagne Gold)

Item No.	Weight	Box	Carton
HES3D-120DC	380g	2pcs	24pcs
HES3D-120DN	380g	2pcs	24pcs

Item Code	Item No.	Finish	Door Width	Door Height	Door Thickness	Door Weight	Door Weight	Opening Angle
170-022-086	HES3D-120DC	Satin Chrome	Max.900mm	Max.2400mm	Min. 29mm	Max.30kg/2pcs	Max.40kg/3pcs	180°
170-022-087	HES3D-120DN	Satin Nickel	Max.900mm	Max.2400mm	Min. 29mm	Max.30kg/2pcs	Max.40kg/3pcs	180°

# 3-WAY ADJUSTABLE CONCEALED HINGE



HES3D-160SL

HES3D-160GL

- 3 WAY adjustment function allows vertical, horizontal, and depth adjustment after hinge installed.
- Easy installation and adjustment.
- Successfully passed 300,000 open/close private cycle tests.
- Supplied with steel flat head screw.
- Cover hides all screw heads for clean appearance.
- Door weight: Max. 45kg/2pcs, 60kg/3pcs
- Door Thickness: Min. 35mm
- Max. Door Size: H 2400mm x W 900mm

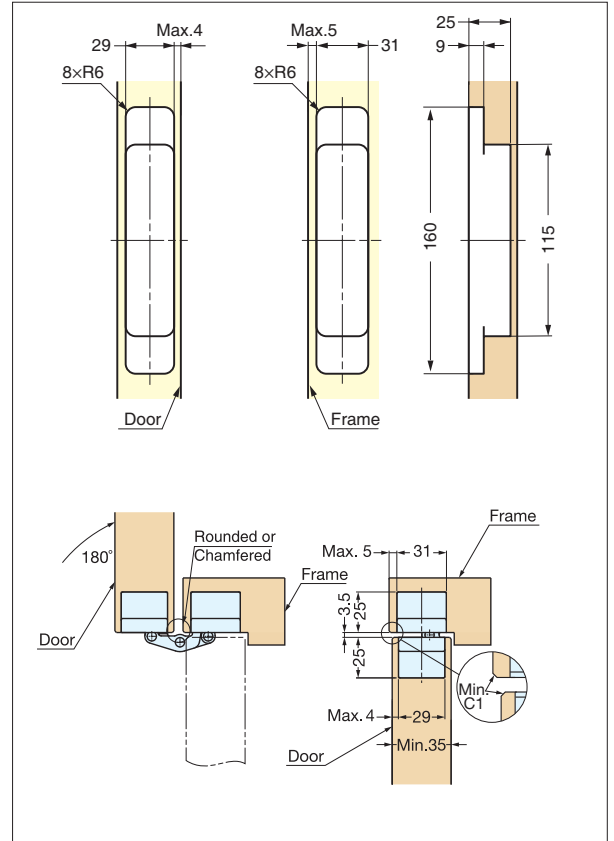
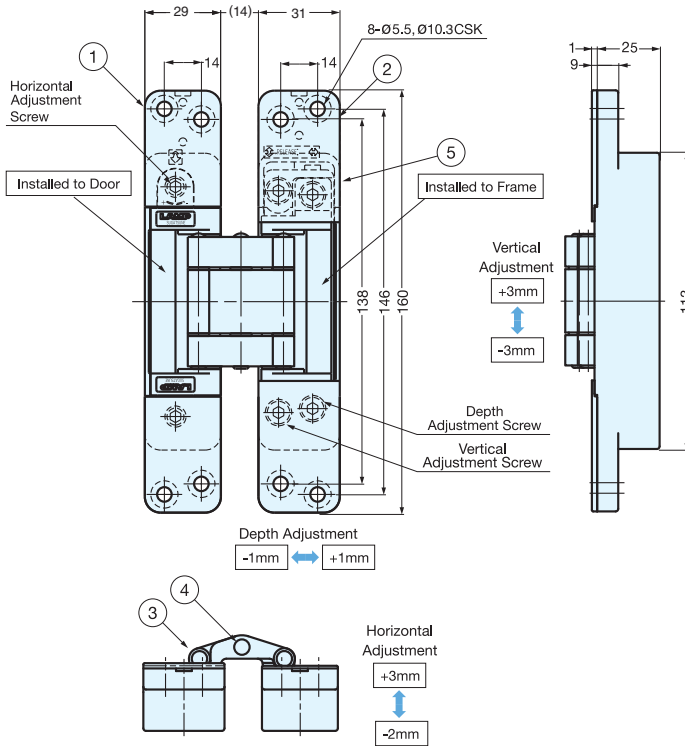

Bore Dimensions

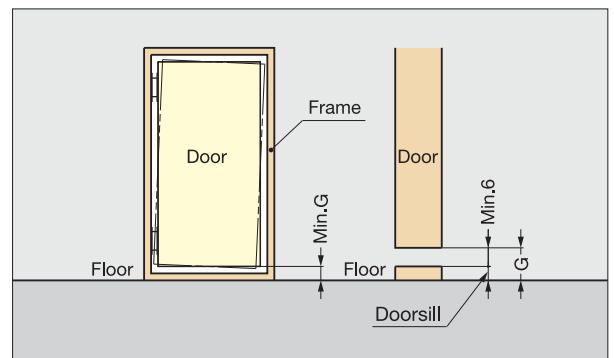

To determine the door and frame dimension, (G) must be taken into account. G = Min. 6 mm + doorsill

No.	Part Name	Material	Finish/Color
①	Body	Zinc Alloy	Matte Silver, Matte Gold
②	Base Frame	Zinc Alloy	Matte Silver, Matte Gold
③	Arm	Aluminum	Matte Silver, Matte Gold
④	Pin	304 Stainless Steel	-
⑤	Cover	ABS	Matte Silver, Matte Gold

Item No.	Weight	Box	Carton
HES3D-160SL	700g	2pcs	12pcs
HES3D-160GL	700g	2pcs	12pcs

Item Code	Item No.	Finish	Door Width	Door Height	Door Thickness	Door Weight	Door Weight	Opening Angle
170-091-009	HES3D-160SL	Matte Silver	Max.900mm	Max.2400mm	Min.35mm	Max.45kg/2pcs	Max.60kg/3pcs	180°
170-091-010	HES3D-160GL	Matte Gold	Max.900mm	Max.2400mm	Min.35mm	Max.45kg/2pcs	Max.60kg/3pcs	180°

# 3-WAY ADJUSTABLE CONCEALED HINGE



# HES3D-E190



HES3D-E190DN

HES3D-E190DC

- 3 WAY adjustment function allows vertical, horizontal, and depth adjustment after hinge installed.
- Easy installation and adjustment.
- Successfully passed 300,000 open/close private cycle tests.
- Supplied with steel flat head screw.
- Cover hides all screw heads for clean appearance.
- Door weight : Max. 100kg
- Door Thickness : Min. 38mm
- Max. Door Size : H 2400mm x W 900mm

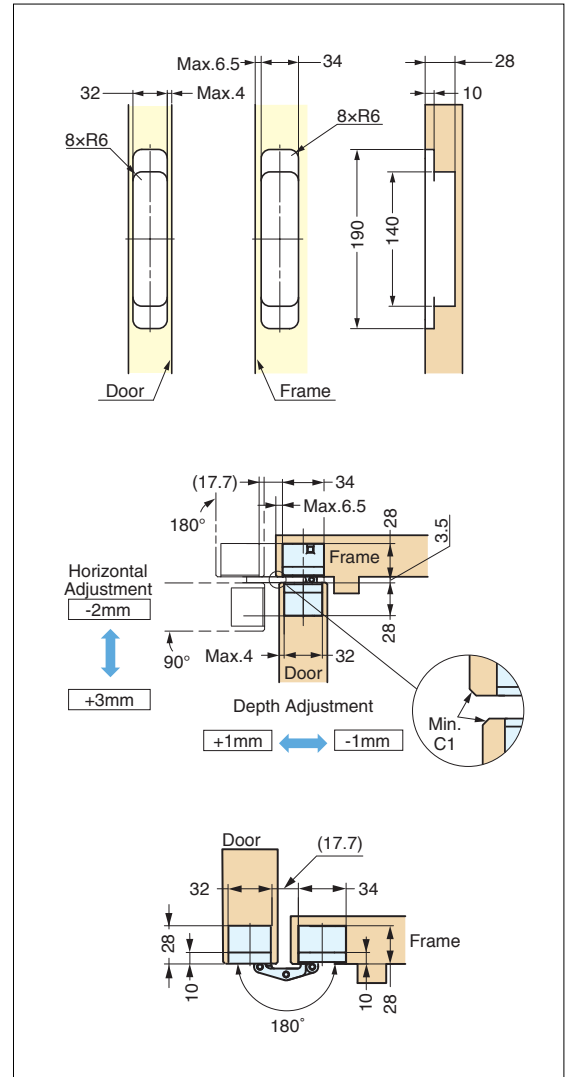
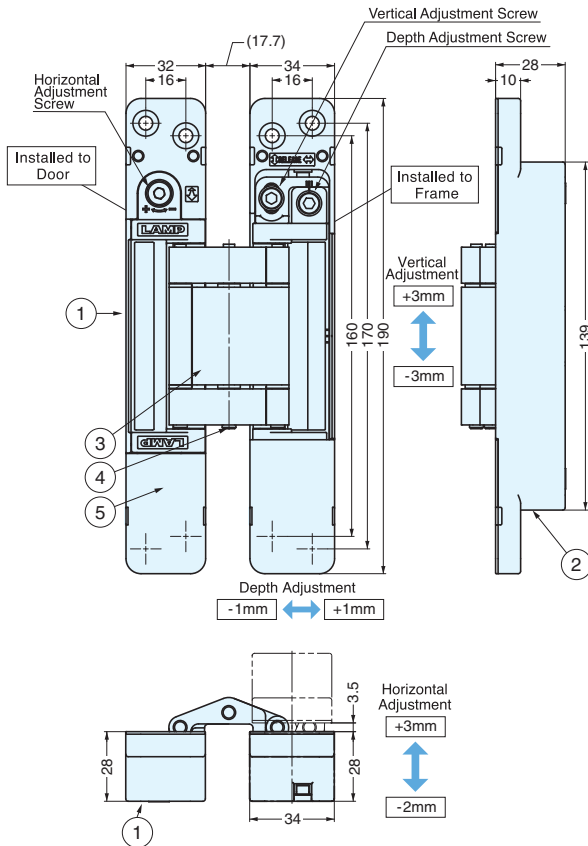

Bore Dimensions

No.	Part Name	Material	Finish/Color
①	Body	Zinc Alloy	Satin Chrome(Silver), Satin Nickel(Champagne Gold)
②	Base Frame	Zinc Alloy	Satin Chrome(Silver), Satin Nickel(Champagne Gold)
③	Arm	Aluminum	Satin Chrome(Silver), Satin Nickel(Champagne Gold)
④	Pin	304 Stainless Steel	-
⑤	Cover	ABS	Satin Chrome(Silver), Satin Nickel(Champagne Gold)

Item No.	Weight	Box	Carton
HES3D-E190DC	1050g	2pcs	12pcs
HES3D-E190DN	1050g	2pcs	12pcs

Item Code	Item No.	Finish	Door Width	Door Height	Door Thickness	Door Weight	Opening Angle
170-025-498	HES3D-E190DC	Satin Chrome	Max.900mm	Max.2400mm	Min. 38mm	Max.100kg	180°
170-025-499	HES3D-E190DN	Satin Nickel	Max.900mm	Max.2400mm	Min. 38mm	Max.100kg	180°

# FLUSH SLIDING DOOR SYSTEM

# MFU-1000

## MonoFlat UNISON®



Open

MFU-1000-L shown.



Close

Door Width	800-1000mm
Door Height	Max. 2500mm
Door Thickness	*28-30mm
Door Weight	Max. 30kg
Adjustability	Depth: ±3.5mm
	Horizontal: ±4mm
	Vertical: ±4mm

\*Can be used on door thicker than 30mm by mortising hanging bracket into the door.

- Flush Surface  
Designed to close flush against surrounding walls, providing clean appearance.
- Unique Movement  
Door moves in first, and then slides sideways.
- Clean Appearance  
No bottom rails on floor required on MFU-1000-R/L

### How the door moves

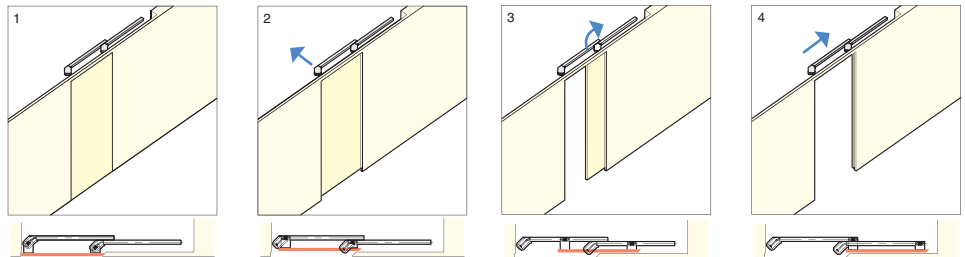

### Installation

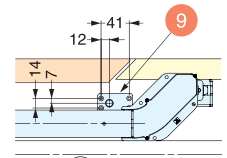
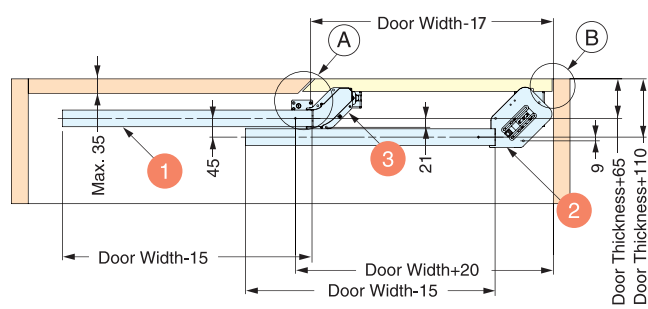
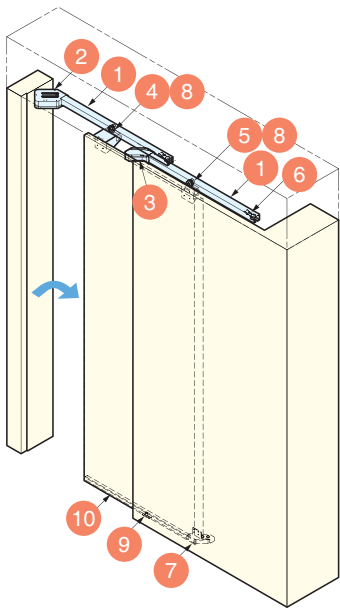

Detail A

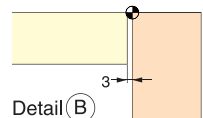

Detail B

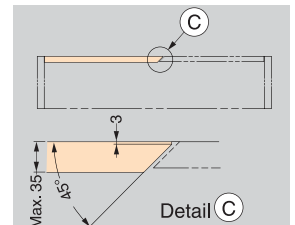

Detail C

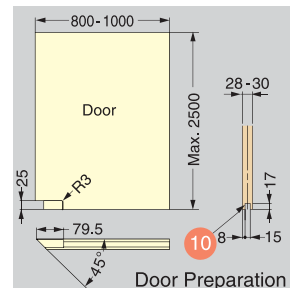

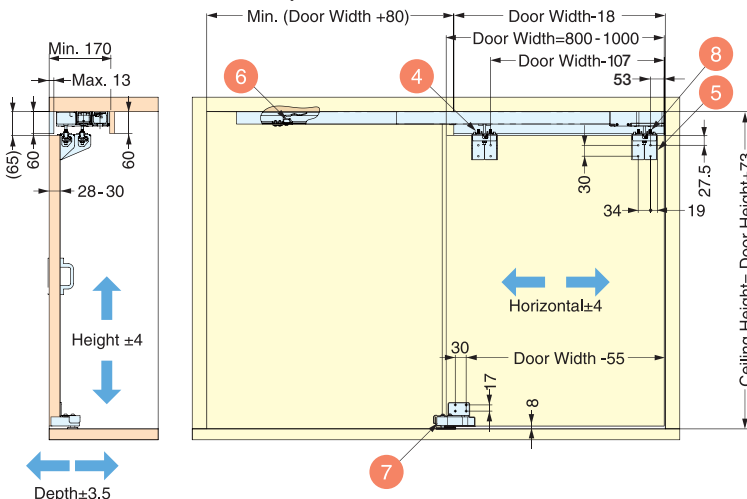

Door Preparation





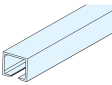
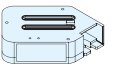
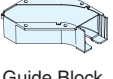

Parts Set (per door)		Necessary Parts	
Item Code	Item No.	Description	
250-022-021	MFU-1000-R	For Right-Handed Opening	
250-022-022	MFU-1000-L	For Left-Handed Opening	

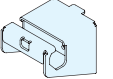
Parts Included

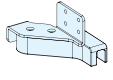
No.	Qty	Part Name	Description
1	2 pcs	 Upper Track • Material / Aluminum • Finish / Anodized	
2	1 pcs	 Guide Block • Material / Aluminum, Polycarbonate • Finish / Silver White	
3	1 pcs	 Guide Block • Material / Aluminum • Finish / Silver	
4	1 pcs	 Upper Bracket A • Material / Steel • Finish / Chromate	
5	1 pcs	 Upper Bracket B • Material / Steel • Finish / Chromate	

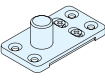
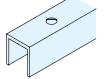
No.	Qty	Part Name	Description
6	1 pcs	 Stopper • Material / PBT, Steel • Finish / White, Yellow Zinc Chromate	
7	1 pcs	 Lower Guide • Material / Steel • Finish / Chromate	
8	2 pcs	 Upper Roller • Material / POM, Steel • Finish / Natural, Chromate	
9	1 pcs	 Bottom Guide Pin • Material / Polyamide • Finish / Yellow Zinc Chromate, Light Brown	
10	1 pcs	 Guide Track • Material / Aluminum • Finish / Anodized	

Installation - With option parts for floor mounted recessed guide track.

Item Code	Item No.	Description	Parts Included
250-023-148	MFU-1000RG-SL-R	For Right-Handed Opening	11 Guide Pin 12 Lower Guide Track 13 Recessed Guide Track
250-023-149	MFU-1000RG-SL-L	For Left-Handed Opening	11 Guide Pin 12 Lower Guide Track 13 Recessed Guide Track

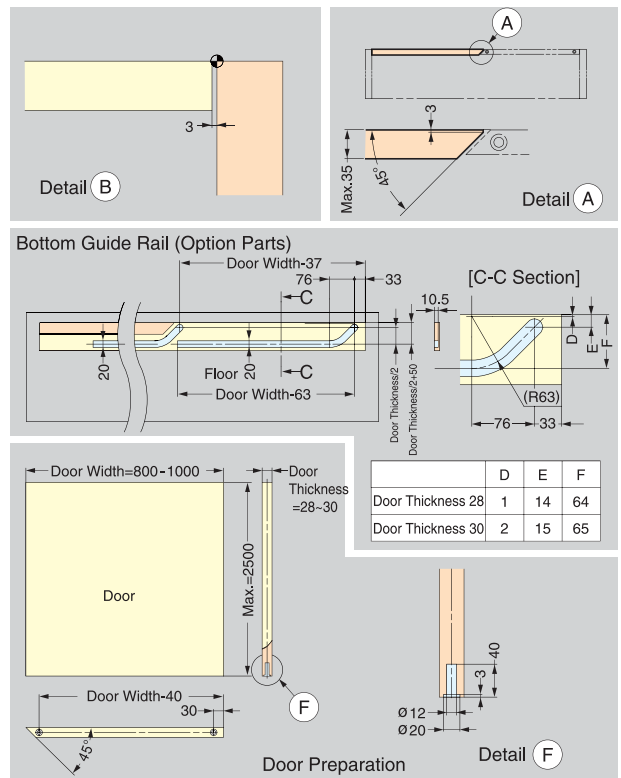
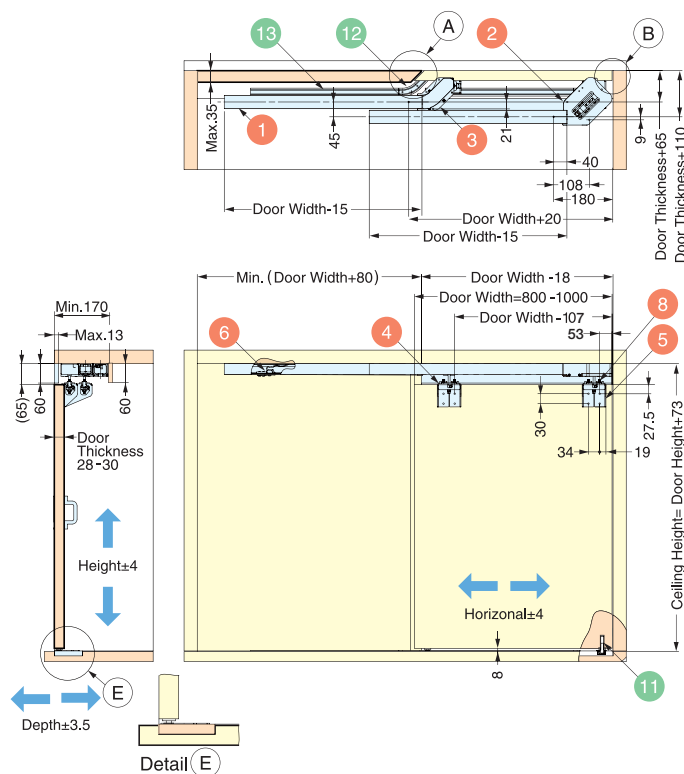



# MonoFlat LIN-X hinge™

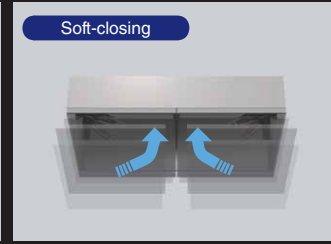

	LIN-X450	LIN-X600
Door Width	400-500mm	550-650mm
Door Height	600-2400mm	600-2400mm
Door Thickness	15-24mm	15-24mm
Door Weight	Max.17kg/Door	Max.24kg/Door

\*Max door weight will vary depending on number of hinges used.

- Lateral swing mechanism  
Allows to swing out laterally in small radius, ideal for tight front space application.
  - Full access to cabinet  
Door will not get in the way when fully opened providing full access to the cabinet.
  - Free swing & soft-close.
  - Easy installation.
  - 4-way adjustable.
  - Various applications - Corner use, double door use & overlapped door use.
- \* Please note handle position on other doors before installation, so that hinges will not interfere with the handles.

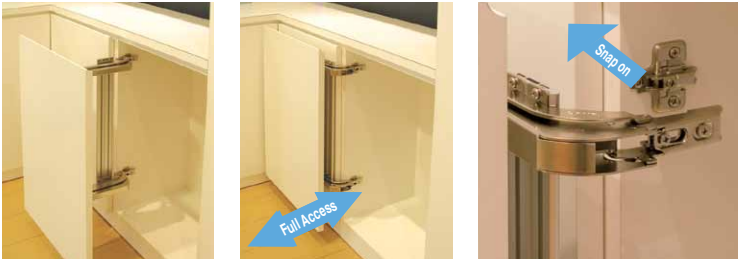

Kitchen Corner (Outside)



Kitchen



TV Base Cabinet



TV Cabinet

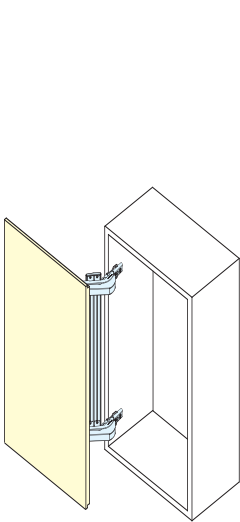

For Small Door

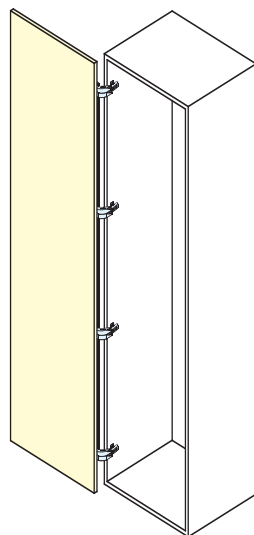

For Large Door

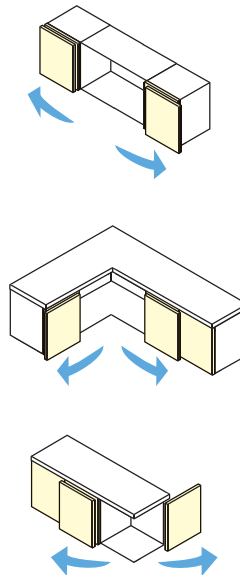

Hinge Body(Close)



Hinge Body(Open)

# MONOFLAT LIN-X HINGE

## LIN-X450

### Standard Kit

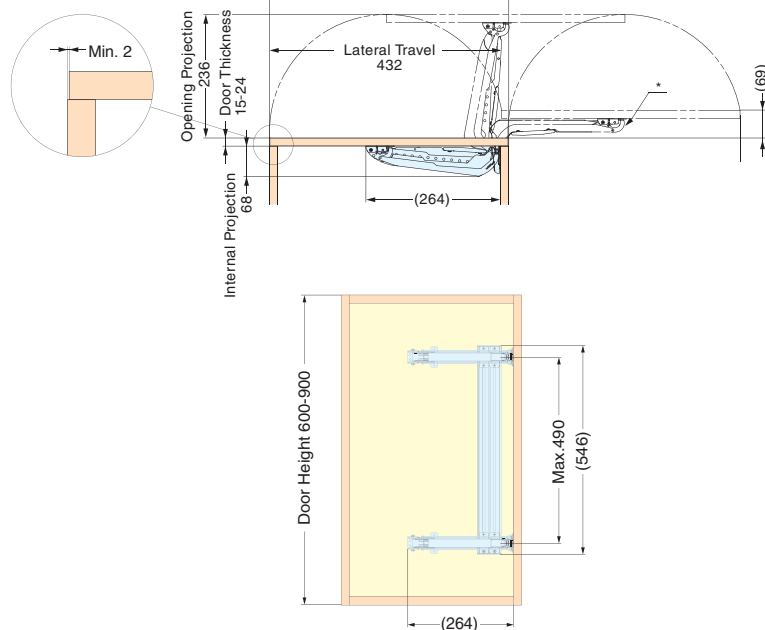
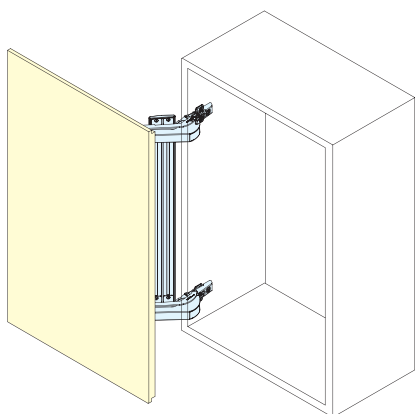

Door Width	400-500mm
Door Height	600-900mm
Door Thickness	15-24mm
Door Weight	Max. 7kg/Door

Item Code	Item No.	Overlay	Mounting Plate	Material	Finish
250-014-240	LIN-X450	19mm	230-P4W-32T	Steel/Aluminum	Nickel/Anodized
250-014-553	LIN-X450+5	14mm	230-P4W-32T+5	Steel/Aluminum	Nickel/Anodized

# MONOFLAT LIN-X HINGE

## LIN-X600

### Standard Kit

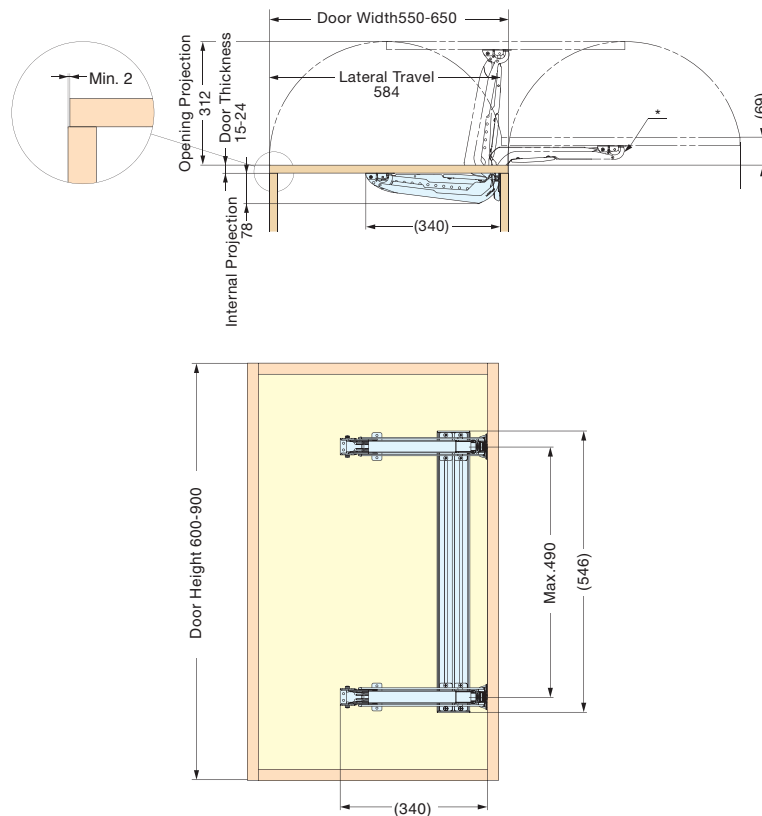
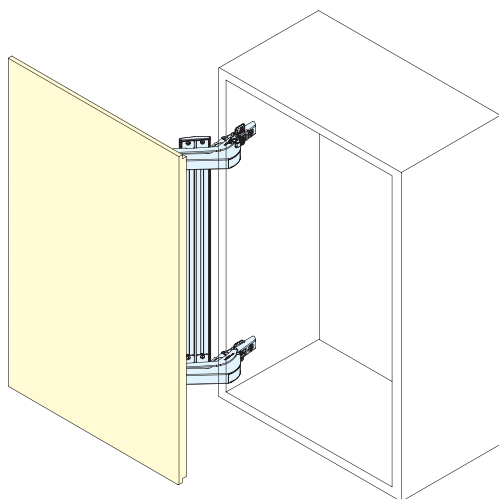

Door Width	550-650mm
Door Height	600-900mm
Door Thickness	15-24mm
Door Weight	Max. 9kg/Door

Item Code	Item No.	Overlay	Mounting Plate	Material	Finish
250-017-590	LIN-X600	19mm	230-P4W-32T	Steel/Aluminum	Nickel/Anodized

Item Code	Item No.	Door Height	Door Weight	Parts Details for LIN-X450			
				Hinge Set (With Damper) Item No. : LIN-X450ACD	Hinge Set (Without Damper) Item No. : LIN-X450A	Connecting Bar Item No. : LIN-X45-Lxxx	End Cap For Connecting Bar Item No. : LIN-X45C
Necessary Quantity							
250-016-704	LIN-X450S-1210	901-1200mm	7.1-10.5kg	3sets	-	840mm x 1 pcs	2pcs
250-016-705	LIN-X450S-1214		10.6-14kg	3sets	1set		2pcs
250-016-707	LIN-X450S-1510	1201-1500mm	7.1-10.5kg	3sets	-	1140mm x 1 pcs	2pcs
250-016-708	LIN-X450S-1514		10.6-14kg	3sets	1set		2pcs
250-016-709	LIN-X450S-1517		14.1-17kg	3sets	2sets		2pcs
250-016-711	LIN-X450S-1810	1501-1800mm	7.1-10.5kg	3sets	-	1440mm x 1 pcs	2pcs
250-016-712	LIN-X450S-1814		10.6-14kg	3sets	1set		2pcs
250-016-713	LIN-X450S-1817		14.1-17kg	3sets	2sets		2pcs
250-016-716	LIN-X450S-2110	1801-2100mm	7.1-10.5kg	3sets	-	1740mm x 1 pcs	2pcs
250-016-717	LIN-X450S-2114		10.6-14kg	3sets	1set		2pcs
250-016-718	LIN-X450S-2117		14.1-17kg	3sets	2sets		2pcs
250-016-723	LIN-X450S-2414	2101-2400mm	10.6-14kg	3sets	1set	2040mm x 1 pcs	2pcs
250-016-724	LIN-X450S-2417		14.1-17kg	3sets	2sets		2pcs

■ Mounting Plate

Item Code	Item No.	Parts	Specification
160-070-041	230-P4W-32T		Material : Steel Finish : Nickel Same quantity with hinge is necessary

■ Door Processing Drawing

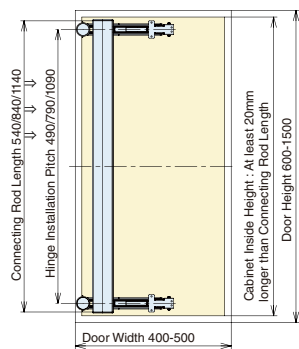
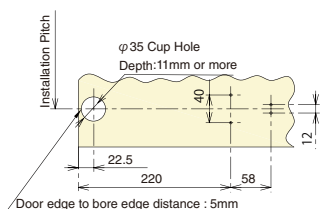

Door Thickness 15-24  
Door Weight up to 7kgf  
2 Hinges per door  
(① LIN-X450ACD : 2 pcs)

■ Cabinet Processing Drawing

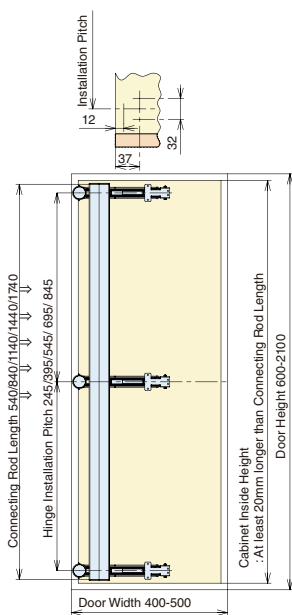

Door Thickness 15-24  
Door Weight up to 10.5kgf  
3 Hinges per door  
(① LIN-X450ACD : 3 pcs)

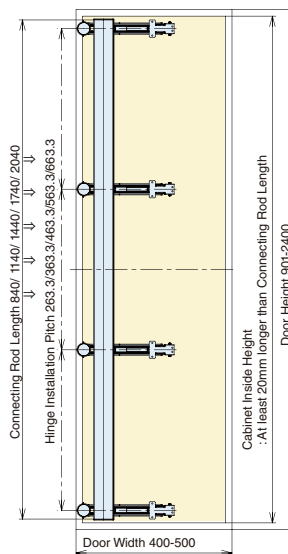

Door Thickness 15-24  
Door Weight up to 14kgf  
4 Hinges per door  
(① LIN-X450ACD : 3 pcs)  
(② LIN-X450A : 1 pcs)  
\*Please install the ② to the second place from the bottom.

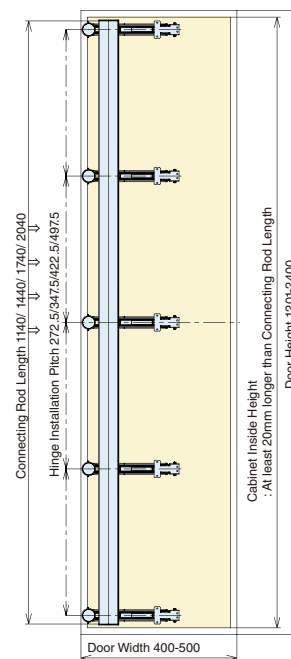

Door Thickness 15-24  
Door Weight up to 17kgf  
5 Hinges per door  
(① LIN-X450ACD : 3 pcs)  
(② LIN-X450A : 2 pcs)  
\*Please install the ② to the 2nd and 3rd place from the bottom.

Item Code	Item No.	Door Height	Door Weight	Parts Details for LIN-X600			
				Hinge Set (With Damper) Item No. : LIN-X600ACD	Hinge Set (Without Damper) Item No. : LIN-X600A	Connecting Bar Item No. : LIN-X60-Lxxx	End Cap For Connecting Bar Item No. : LIN-X60C
Necessary Quantity							
250-017-068	LIN-X600S-1212	901-1200mm	Less than 12kg	2sets	-	840mm x 1pcs	2pcs
250-017-069	LIN-X600S-1216		12.1-16kg	3sets	-		2pcs
250-017-071	LIN-X600S-1516	1201-1500mm	Less than 16kg	3sets	-	1140mm x 1pcs	2pcs
250-017-072	LIN-X600S-1520		16.1-20kg	3sets	1set		2pcs
250-017-074	LIN-X600S-1816	1501-1800mm	Less than 16kg	3sets	-	1440mm x 1pcs	2pcs
250-017-075	LIN-X600S-1820		16.1kg-20kg	3sets	1set		2pcs
250-017-493	LIN-X600S-1824		20.1-24kg	3sets	2sets		2pcs
250-017-077	LIN-X600S-2116	1801-2100mm	Less than 16kg	3sets	-	1740mm x 1pcs	2pcs
250-017-078	LIN-X600S-2120		16.1kg-20kg	3sets	1set		2pcs
250-017-079	LIN-X600S-2124		20.1-24kg	3sets	2sets		2pcs
250-017-082	LIN-X600S-2420	2101-2400mm	Less than 20kg	3sets	1set	2040mm x 1pcs	2pcs
250-017-083	LIN-X600S-2424		20.1-24kg	3sets	2sets		2pcs

■ Mounting Plate

Item Code	Item No.	Parts	Specification
160-070-041	230-P4W-32T		Material : Steel Finish : Nickel *Same quantity with hinge is necessary

■ Door Processing Drawing

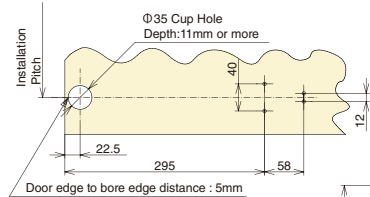

■ Cabinet Processing Drawing

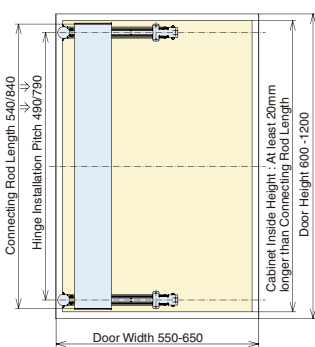
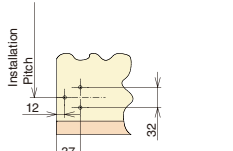

2 Hinges per door  
① LIN-X600 ACD : 2 pcs

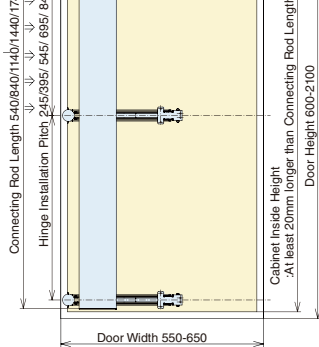

3 Hinges per door  
① LIN-X600 ACD : 3 pcs

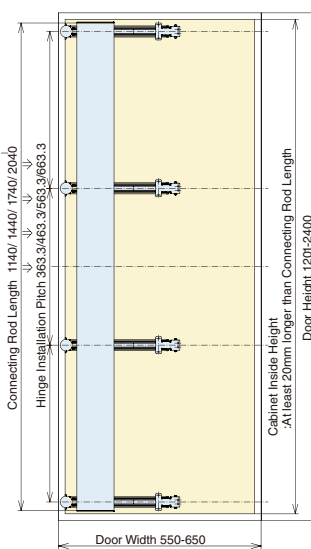

4 Hinges per door  
① LIN-X600 ACD : 3 pcs  
② LIN-X600 A : 1 pcs  
\* Please install the ② to the 2nd place from the bottom.

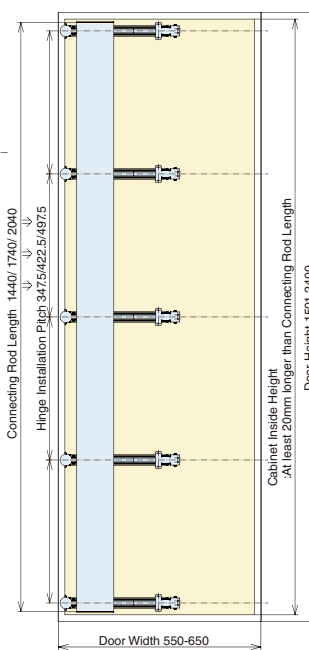

5 Hinges per door  
① LIN-X600 ACD : 3 pcs  
② LIN-X600 A : 2 pcs  
\* Please install the ② to the 2nd and 3rd place from the bottom.



# MonoFlat FAD™

Door Width	270-350mm
Door Height	260-650mm
Door Thickness	15-20mm
Door Weight	Max.5kg/Door

## MONOFLAT FAD (For Light Weight Doors)

## FAD-5

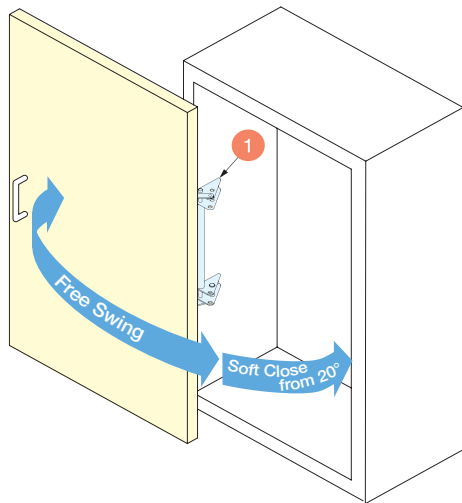

- Lateral swing mechanism  
Allows doors to swing out laterally in a small radius, ideal for tight front space application.
- Free swing & soft-close
- 3-Way adjustable
- Various applications  
Can be used in single or double door configuration.  
Ideal for cabinets in kitchen, bathroom, laundry room etc.  
\*For overlay use.

- Other "MonoFlat series" available.
  - MonoFlat FAD-20 For door weight 20kg
  - MonoFlat LIN-X For door weight 24kg
  - MonoFlat Unison For door weight 30kg
  - MonoFlat FAD-44 For door weight 35kg
  - MonoFlat FAD-54 For door weight 35kg

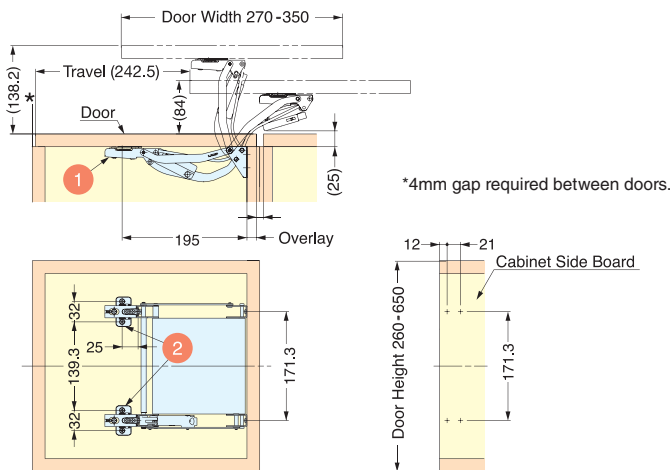

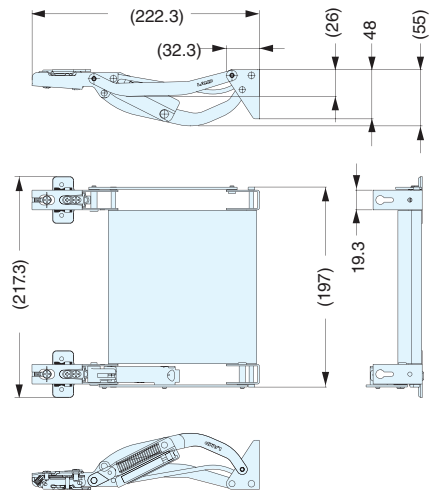

### ■ Hinge Dimensions



Item Code	Item No.	Box
250-016-605	FAD-5	1set

1set includes both hinge body and mounting plates.

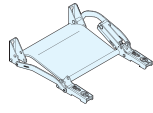
### ■ Part Details

No.	Qty	Part Name	Material/Finish
1	1pcs	 Hinge Body	<ul style="list-style-type: none"> <li>• Material Aluminum, Polyacetal, Steel</li> <li>• Finish / Color Anodized, Grey, Nickel</li> </ul>
2	2pcs	 Mounting Plate	<ul style="list-style-type: none"> <li>• Material Steel</li> <li>• Finish Nickel</li> </ul>

# FOLDING POCKET DOOR SYSTEM

## ALT-F



- Folding door is stored inside the cabinet.
- Support cabinet with less depth.
- Inset use.
- Applications: Ideal for audio visual, office, kitchen, wardrobe etc.

Door Width	Max. 450mm
Door Height	Max. 1830mm
Door Thickness	23-30mm
Door Weight	Max. 10kg/Door

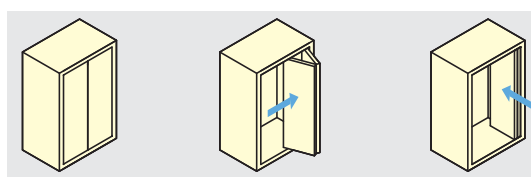

### ■ Preparation

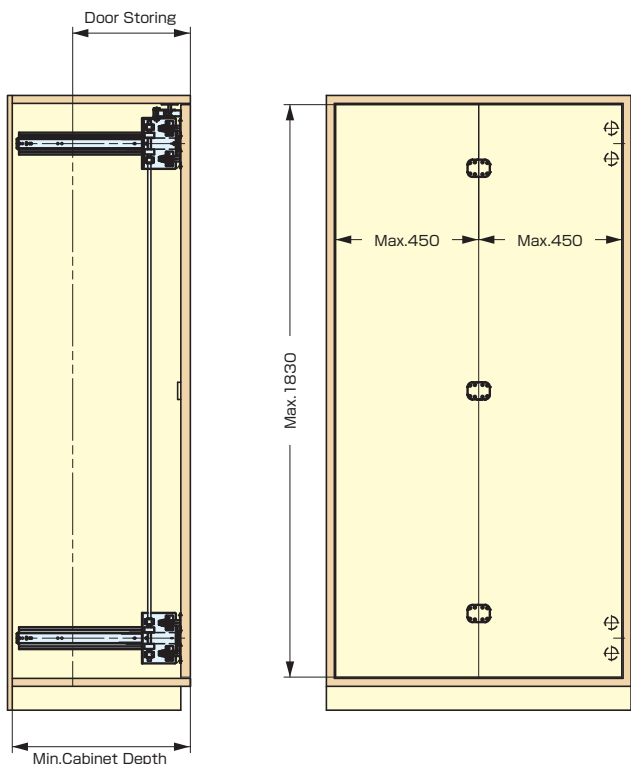

### ■ Top View

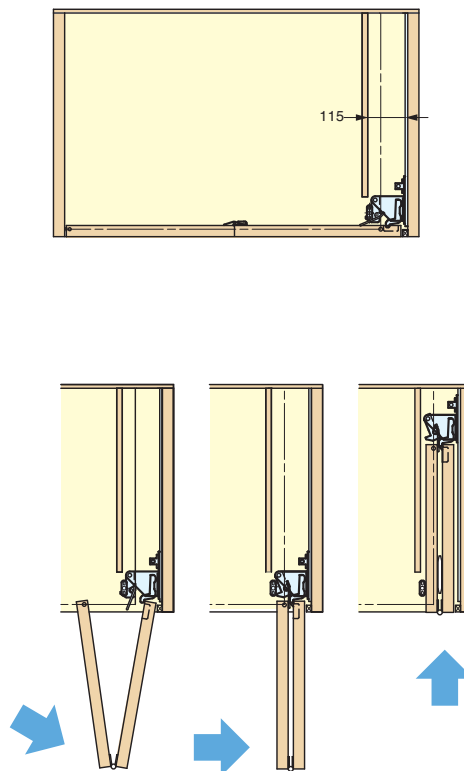

Item Code	Item No.	Pocket Space	Door Storing	Min. Cabinet Depth
180-022-294	ALT-F18L	Left	355.6mm	466.7 + Door Thickness
180-022-295	ALT-F18R	Right	355.6mm	466.7 + Door Thickness
180-022-296	ALT-F20L	Left	406.4mm	517.5 + Door Thickness
180-022-297	ALT-F20R	Right	406.4mm	517.5 + Door Thickness

# SLS-ELAN

## EASY LIFT-UP STAY

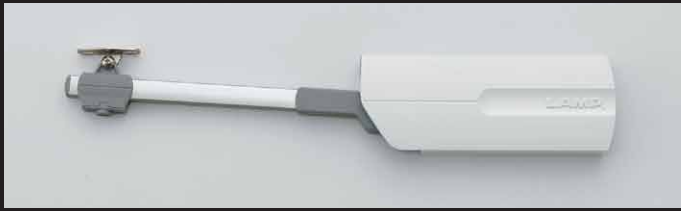

- Lift-assist mechanism for extra light-opening with free stop feature.
- Offers smooth and soft downward movement preventing lids or doors from slamming shut.
- Easy to install by aligning the body to the edge of cabinet.
- Recognized by LGA for 40,000 cycles.

### ■ 3 functions on 1 stay

#### 1. Lift-assist



#### 2. Free stop



#### 3. Soft-close

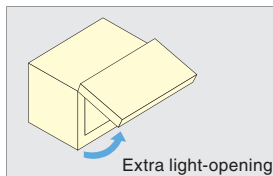
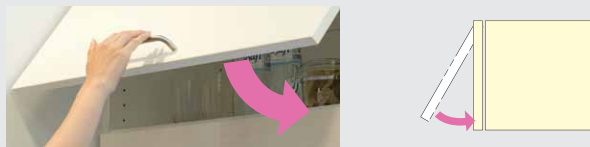

Designed to operate at room temperature  
0°-40°C.



### ■ Easy Installation

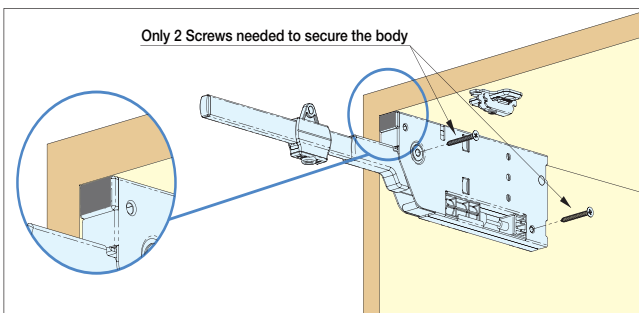

### ■ Adjustment

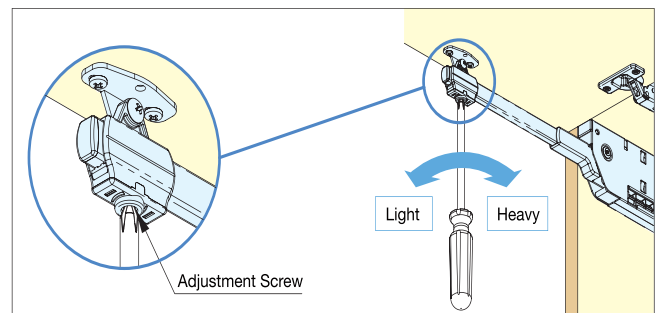



# EASY LIFT-UP STAY



# SLS-ELAN



- For forward-opening flap door with concealed, piano, butt, hinges.
- Designed to provide effortless opening and hold door in closed and opened position.
- Damper equipped for soft & silent closing.
- Optional bracket for aluminum frame door available.
- Single or pair use allows wide range of door sizes/weights.
- Successfully passed 40,000 open / close cycle test.

### ■ Door Size Ranges

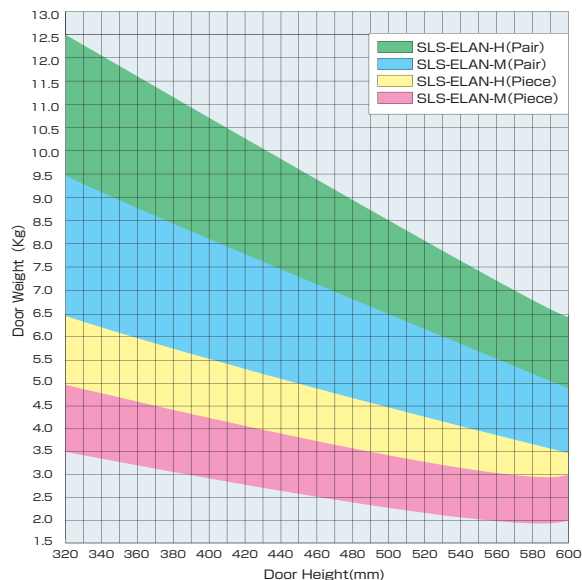

For heavier flap application, please contact your local dealer or Sugatsune office.

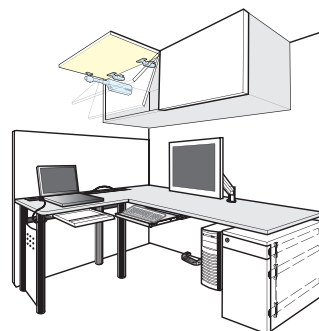
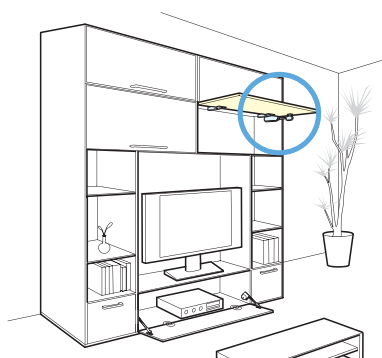
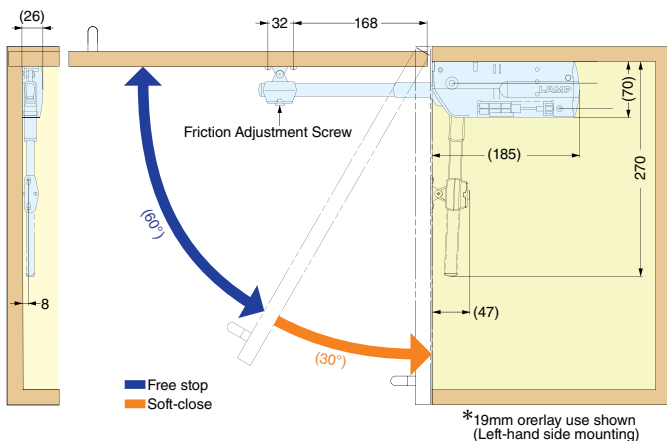

Item Code	Item No.	Type	Torque per piece	Material	Finish/Color	Weight	Carton
180-014-523	SLS-ELAN-ML	M-Type(Left)	50-75kgf·cm	Aluminum Alloy, ABS	Anodized, Light Grey	600g	20pcs
180-014-524	SLS-ELAN-MR	M-Type(Right)	50-75kgf·cm	Aluminum Alloy, ABS	Anodized, Light Grey	600g	20pcs
180-014-525	SLS-ELAN-HL	H-Type(Left)	75-100kgf·cm	Aluminum Alloy, ABS	Anodized, Light Grey	600g	20pcs
180-014-526	SLS-ELAN-HR	H-Type(Right)	75-100kgf·cm	Aluminum Alloy, ABS	Anodized, Light Grey	600g	20pcs

# MOUNTING PLATE FOR THIN ALUMINUM FRAME DOOR SLS-ELAN-AZ

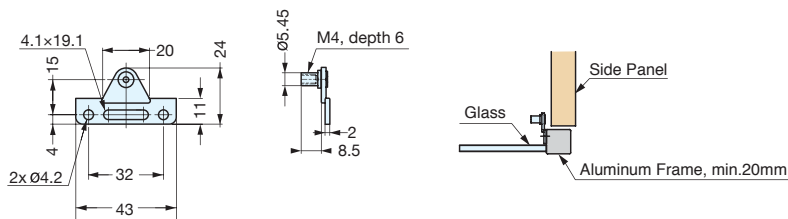

Item Code	Item No.	Type	Material	Finish	Box	Carton
180-017-647	SLS-ELAN-AZ	Mounting Plate	Steel	Nickel	320pcs	1280pcs
180-018-555	SLS-ELAN-AZS	Screw Set	Steel	Nickel	80sets	800sets

# LIFT ASSIST STAY



**EZS-ELAN**



- Lapcon stay for upward-opening flap doors.
- Door opens over the cabinet.
- Lift-assist mechanism for extra light-opening.
- Door stays in any desired position.
- Damper equipped for soft & silent closing at the end.
- Slim design and installed location maximizes space inside of cabinet.
- Simple installation by aligning body to edge of cabinet.
- No hinges/connecting bar needed.
- Door height adjustable.
- Successfully passed 30,000 open/close private cycle tests.
- Recommended Door Size and Weight:
  - Width : Max. 1200mm
  - Height : 500-750mm/Door
  - Weight : 5-12.5kg/Door
- Sold per pair.

## 3 functions on 1 stay

### 1. Lift-assist

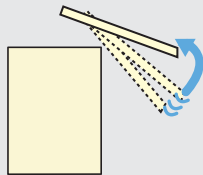

### 2. Free stop

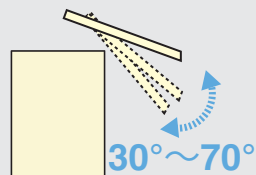

### 3. Soft-close

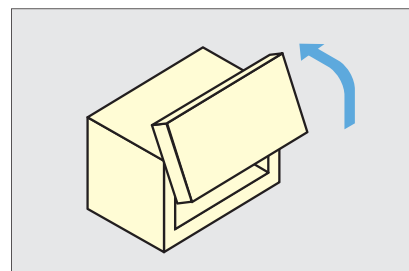
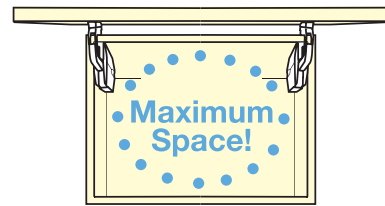
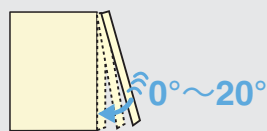

## Easy Installation

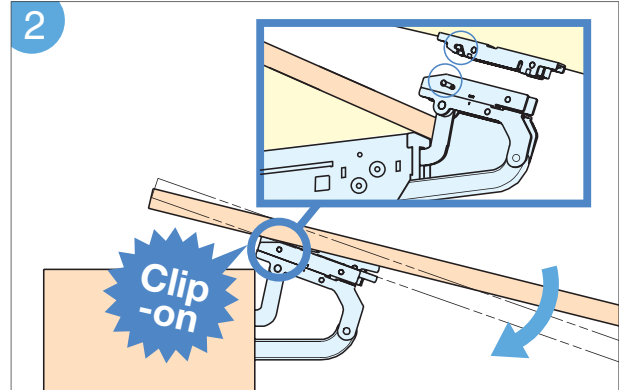
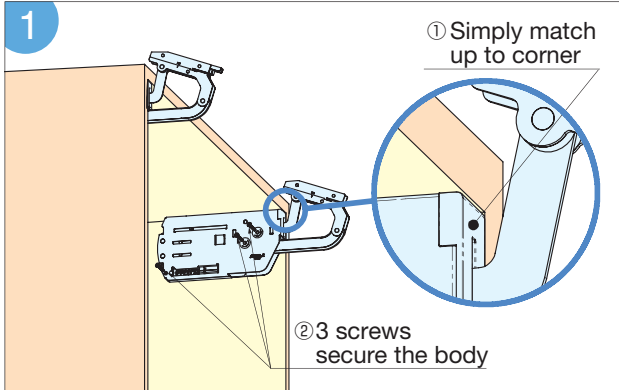

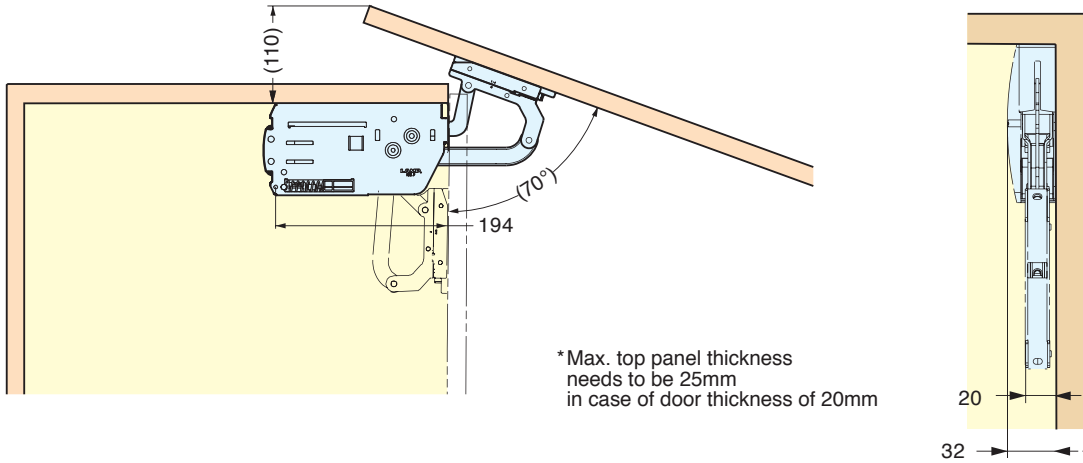

\* Max. top panel thickness needs to be 25mm in case of door thickness of 20mm

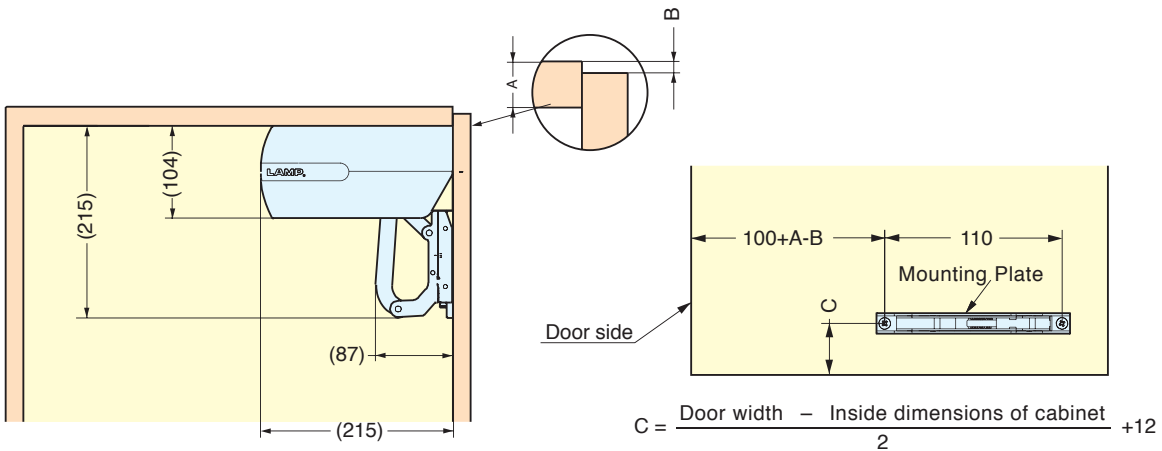

■ Door Size Range

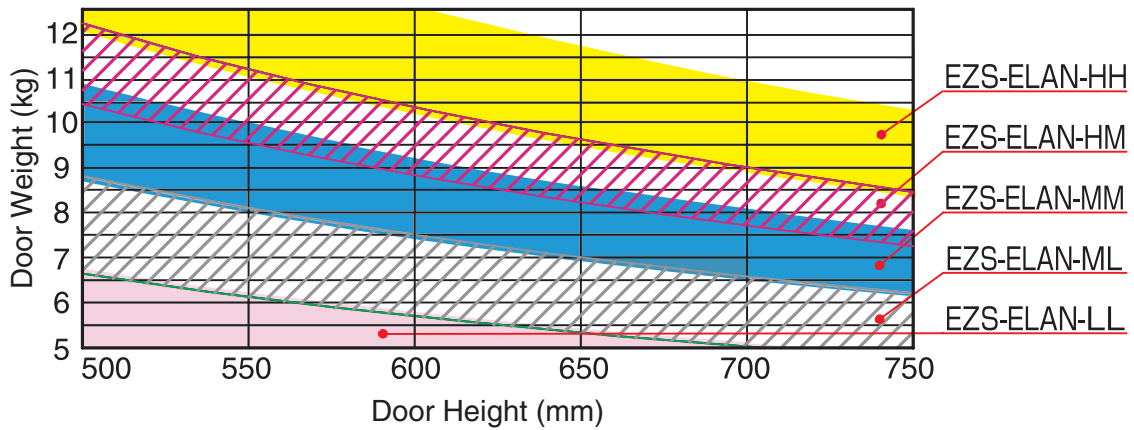

■ Lifting power

Door height (mm) x (Door weight (kg) -1)

Lifting Power	Model
1900-2860	EZS-ELAN-LL
2820-3900	EZS-ELAN-ML
3850-4950	EZS-ELAN-MM
4700-5600	EZS-ELAN-HM
5550-6930	EZS-ELAN-LH

Item Code	Item No.	Part Name	Material	Finish/Color	Weight	Carton
180-018-923	EZS-ELAN-L	Body	Steel / POM, ABS	Nickel, Light Grey	2240g	5sets
180-018-924	EZS-ELAN-M	Body	Steel / POM, ABS	Nickel, Light Grey	2400g	5sets
180-018-925	EZS-ELAN-H	Body	Steel / POM, ABS	Nickel, Light Grey	2480g	5sets
180-018-983	EZS-ELAN-COVER	Cover	ABS	Light Grey	160g	5sets

# BI-FOLD LIFT ASSIST STAY



## HBF-ELAN



- Bi-fold door mechanism will assist in opening and closing doors in a smooth motion.
- Easy installation using a paper template and multiple adjustments.
- Recommended Door Size and Weight:
  - Width : Max. 1200mm
  - Height : 320-370mm
  - Weight : 2.5-6.5kg/Door

### Multiple Adjustments

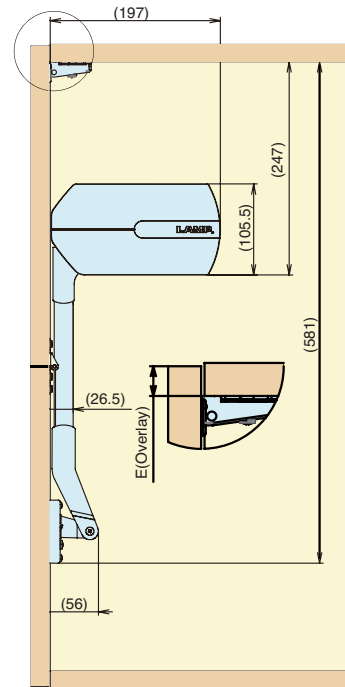
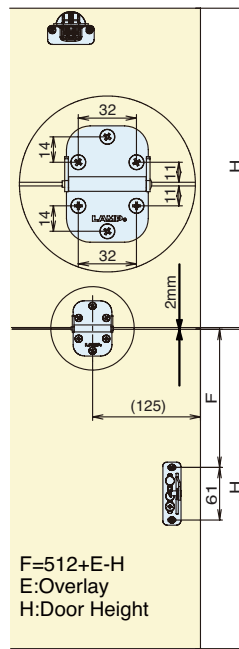
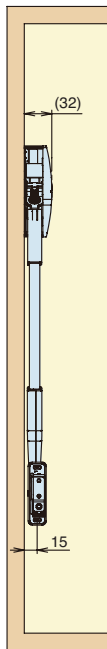
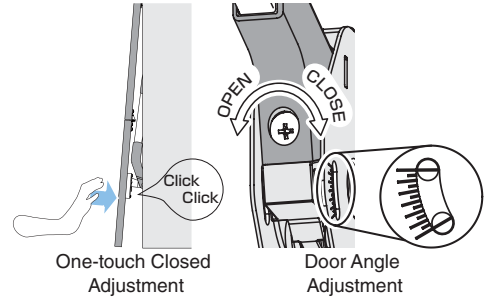

### Opening Dimensions

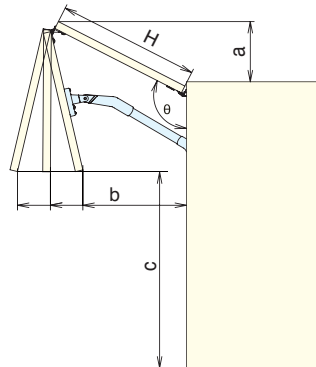

Opening angle	H: Door height								
	320			350			370		
	a	b	c	a	b	c	a	b	c
105°	58	364	341	65	348	373	69	314	399
110°	85	364	369	93	344	402	99	303	431
120°	134	359	424	148	330	459	157	270	492

Item Code	Item No.	Door Weight/Door	Material	Finish/Color	Weight	Carton
180-024-608	HBF-ELAN-LL	2.5-3.3kg	Aluminum Alloy, ABS	Anodized, Light Grey	2.6kg	5sets
180-024-609	HBF-ELAN-ML	3.3-4.1kg	Aluminum Alloy, ABS	Anodized, Light Grey	2.6kg	5sets
180-024-610	HBF-ELAN-MM	4.1-4.9kg	Aluminum Alloy, ABS	Anodized, Light Grey	2.6kg	5sets
180-024-611	HBF-ELAN-HM	4.9-5.7kg	Aluminum Alloy, ABS	Anodized, Light Grey	2.6kg	5sets
180-024-612	HBF-ELAN-HH	5.7-6.5kg	Aluminum Alloy, ABS	Anodized, Light Grey	2.6kg	5sets

# SWING LIFT-UP STAY



## SLU-ELAN

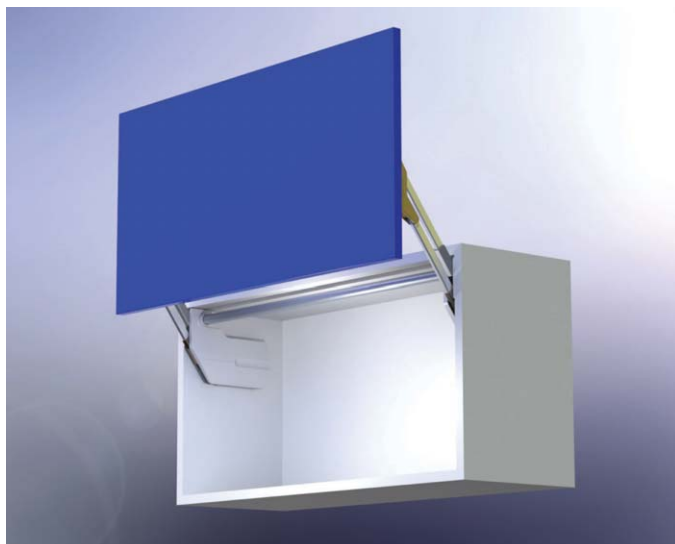

- Lapcon stay for swing lift-up doors.
- Lift-assist mechanism for extra light-opening.
- Door stays in any desired position.
- Damper equipped for soft & silent closing at the end.
- Simple installation by mounting guide plate and slide in main body.
- No hinges are required.
- Connecting bar stays on top for maximum access inside the cabinet.
- Recommended Door Size and Weight :
  - Width : Max. 1800mm
  - Height : 390-500mm/Door
  - Weight : 5-11kg/Door

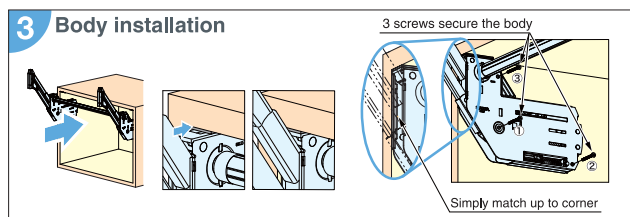
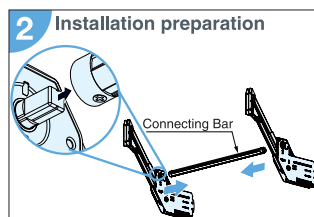
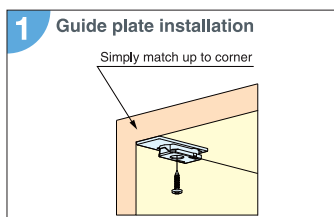
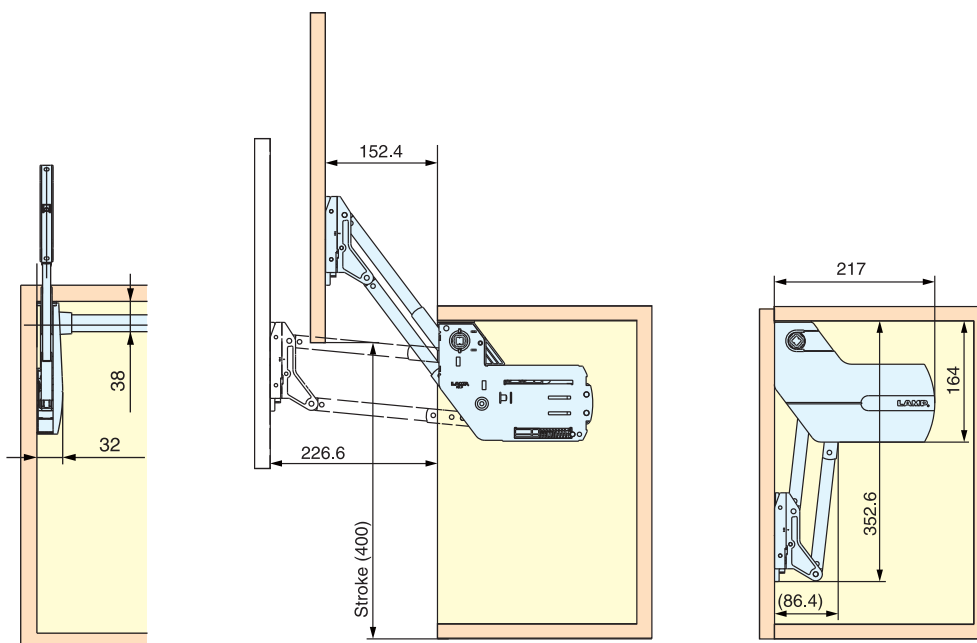

Item Code	Item No.	Door Weight/Door	Material	Finish/Color	Weight	Carton
180-022-312	SLU-ELAN S4	5.0-6.5kg	Aluminum Alloy, ABS	Anodized, Light Grey	3.0kg	5sets
180-022-313	SLU-ELAN L4	6.5-8.0kg	Aluminum Alloy, ABS	Anodized, Light Grey	3.0kg	5sets
180-022-314	SLU-ELAN M4	8.0-9.5kg	Aluminum Alloy, ABS	Anodized, Light Grey	3.1kg	5sets
180-022-315	SLU-ELAN H4	9.5-11.0kg	Aluminum Alloy, ABS	Anodized, Light Grey	3.2kg	5sets

\*Min. inside cabinet height is 360mm / \*Door weight includes handle.

### ■ Connecting Bar (Sold separately)

Item Code	Item No.	Cabinet Width	Cabinet Inside Width
180-022-319	ELB-480	600mm	556-566mm
180-022-320	ELB-780	900mm	856-866mm
180-022-321	ELB-1080	1200mm	1156-1166mm
180-022-322	ELB-1380	1500mm	1456-1466mm
180-026-323	ELB-1680	1800mm	1756-1766mm

\*For other dimensions, the bar can be cut on site.

# SWING DOWN STAY



SLD



- Unique swing down mechanism will hold doors at the open position.
- Sleek & compact design.
- Easy installation.
- Adjustable arm mounting plate.
- Patented LAPCON technology provides a smooth and quiet motion.
- Successfully passed 30,000 open/close private cycle tests.
- Recommended Door Size and Weight:
  - Width : 600-900 mm
  - Height : 390-400 mm ( For 18mm thickness door )
  - Weight : 3-6 kg

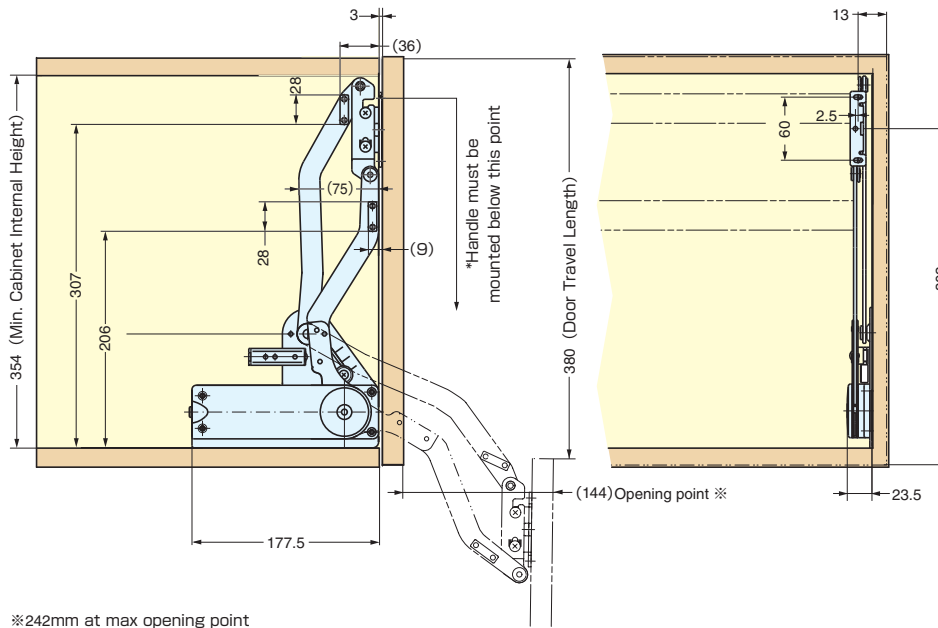
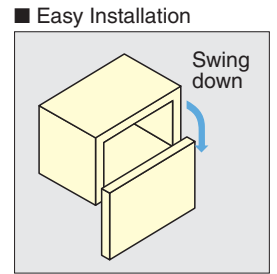
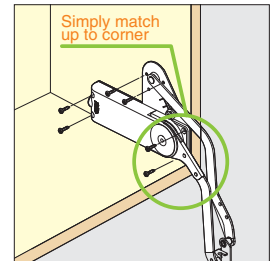
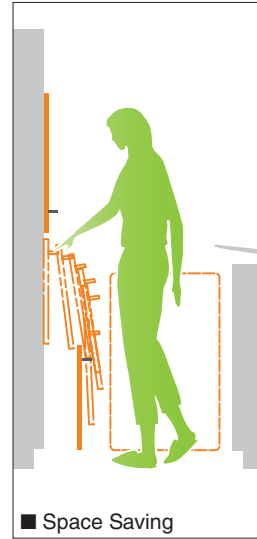

■ Body(set)

Item Code	Item No.	Door Weight/Door	Material	Finish/Color	Weight	Box
180-020-848	SLD-3	3.0-4.0kg	Steel, Plastic	Chrome, Grey	1.9kg	5sets
180-020-849	SLD-4	4.0-5.0kg	Steel, Plastic	Chrome, Grey	1.9kg	5sets
180-020-850	SLD-5	5.0-6.0kg	Steel, Plastic	Chrome, Grey	1.9kg	5sets

■ Guide Bar(Sold separately)

Item Code	Item No.	Door Spec.	Guide bar for cabinet width 600mm	Guide bar for cabinet width 900mm
180-120-287	SLUB-535	Solid Wood Door	535	-
180-104-088	SLUB-551	Frame Door	551	-
180-120-288	SLUB-835	Solid Wood Door	-	835
180-100-131	SLUB-851	Frame Door	-	851

# SELF CLOSE STAY



# HDS-10S



- For downward opening flaps.
- Stays opened in the down position.
- Self-closes after a small impulse.
- Torque range (Door height x 1/2 x Door weight) 60-160kgf·cm

※For further details, please contact local representatives.

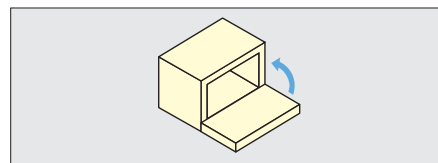

## Installation

### With Piano-Butt Hinge

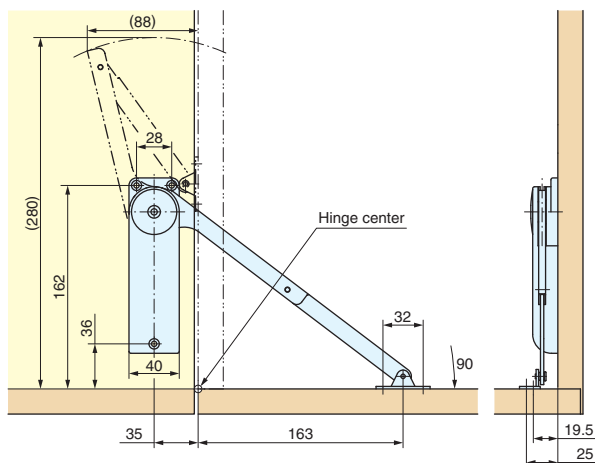

### With Drop Hinge (SDH-001)

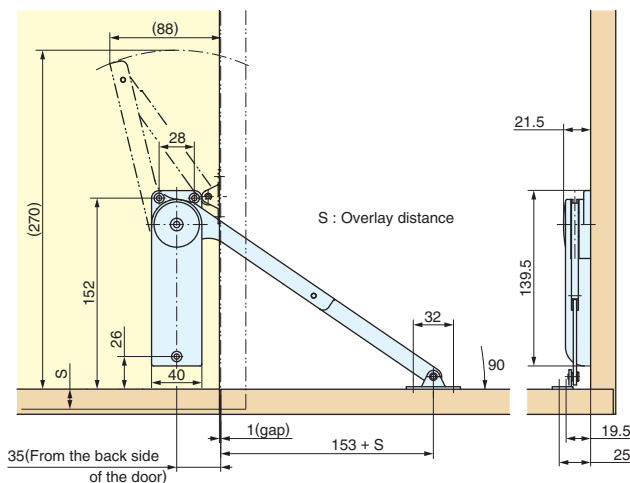

## Movement

### K type

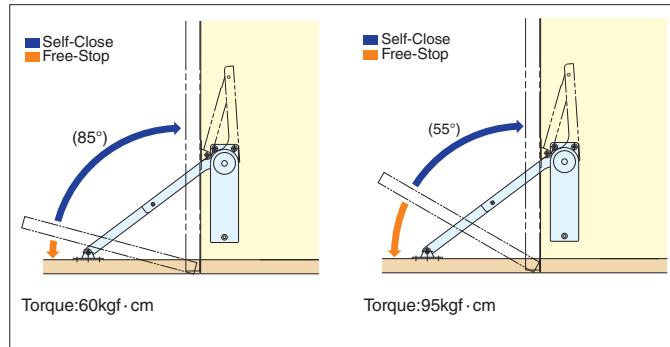

### M/H type

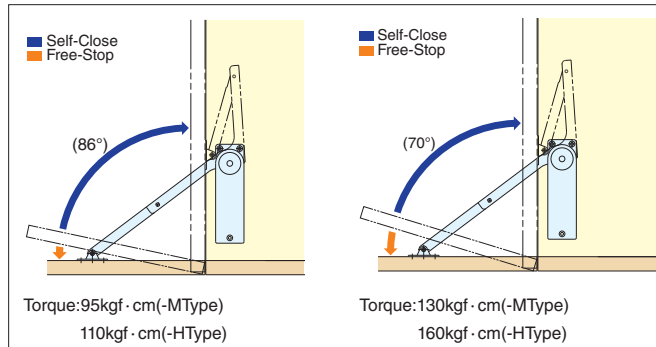

Hinge Type	A	B	C	D
Drop Hinge	165	35	48-S	174-S
Piano/Butt Hinge	159		42	168

Item Code	Item No.	Torque Moment (pair)	Angle of Self Close	Material	Finish/Color
-	HDS-10S-K	60-95kgf·cm	Approx. 85-55°	Steel, Plastic	Nickel, Black or White
-	HDS-10S-M	95-130kgf·cm	Approx. 86-70°	Steel, Plastic	Nickel, Black or White
-	HDS-10S-H	110-160kgf·cm	Approx. 86-70°	Steel, Plastic	Nickel, Black or White



# Soft & Smooth Movement

Lapcon series products provide the smoothest opening and closing system imaginable, equipped with Sugatsune's built-in patented dampening device.

## Other Lapcon Solutions

SOFT-DOWN STAY - SDS (No.182 P.217~)

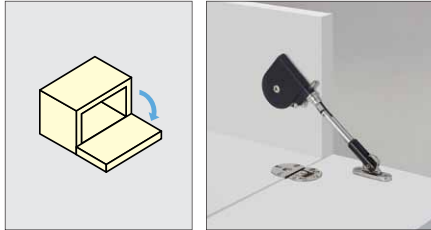

LIFT ASSIST STAY - HBFN (No.182 P.231~)

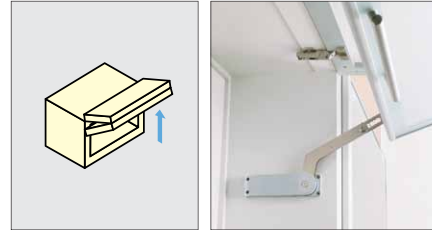

SOFT-DOWN STAY - NSDX (No.182 P.223~)

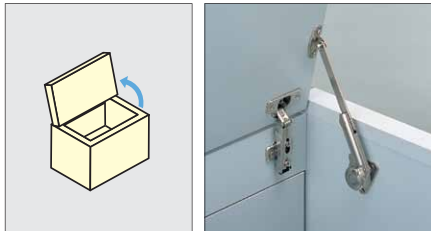

SWING LIFT-UP STAY - SLUN (No.182 P.233~)

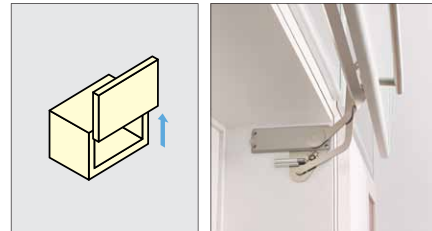

SOFT-DOWN STAY - HDS, HDSN (No.182 P.227~)

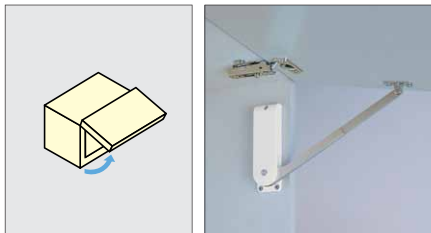

FLIPPER DOOR STAY - OV-EZ (No.182 P.241~)

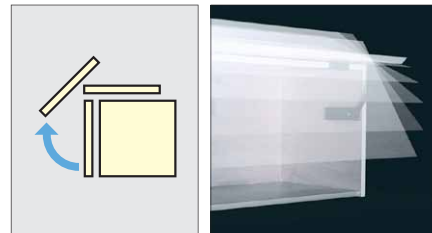

SOFT-CLOSE HINGE - HG-JHM (No.182 P.187~)

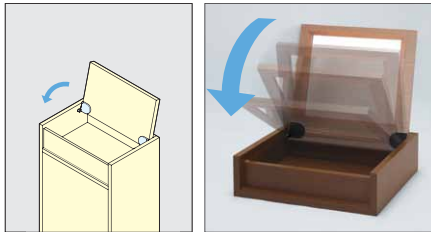

FLIPPER DOOR STAY - OVN (No.182 P.239~)

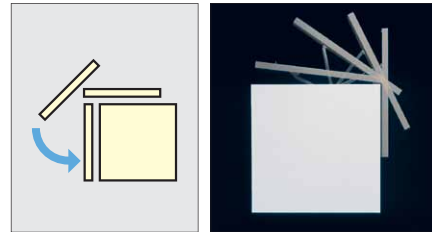

MINI-DOOR CLOSER - YMC (No.182 P.263~)

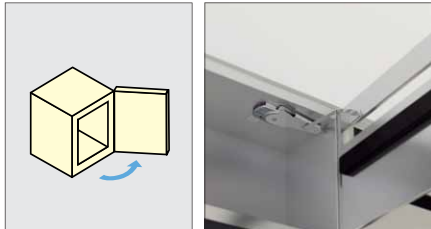

FLIPPER DOOR STAY - OV (No.182 P.237~)

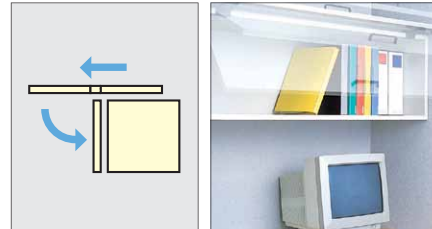

DISK DAMPER - UDD

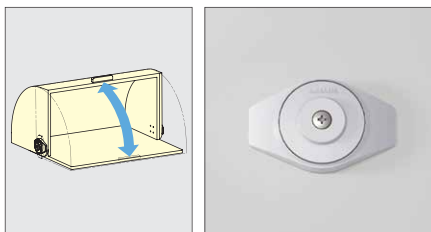

FLIPPER DOOR STAY - IF (No.182 P.243~)

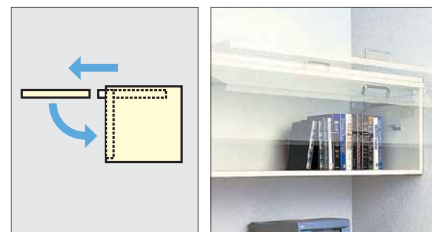





Please consult the  
**SUGATSUNE**  
Furniture & Architectural  
Hardware catalogue No. 182  
for the complete range  
of solutions.

## Zwei L

P. 1~

- Zwei L KNOBS & HANDLES
- Zwei L PULLS
- Zwei L HOOKS
- Zwei L GLASS SHELF CLAMPS
- Zwei L DOOR LATCH & HANDLES
- Zwei L HINGES
- Zwei L DOOR STOPPERS
- Zwei L LEVER BOLTS



## HANDLES, PULLS & KNOBS

P. 40~

- HANDLES
- RECESSED PULLS
- PULLS
- KNOBS
- HATCH PULLS
- PUSH KNOBS



## CATCHES & LATCHES

P. 88~

- KNUCKLE CATCHES
- TENSION CATCHES
- MAGNETIC CATCHES
- NON-MAGNETIC TOUCH LATCHES
- PUSH KNOB LATCHES
- DRAW LATCHES
- SLIDE BOLTS
- HASP



## HINGES

P. 154~

- BUTT HINGES
- LIFT-OFF HINGES
- QUICK RELEASE HINGES
- ANGLE, PIVOT & TABLETOP HINGES
- DETENT HINGES
- TORQUE & DAMPER HINGES
- CONCEALED HINGES



## LID SUPPORTS

P. 214~

- SOFT-DOWN STAY
- VERTICAL SWING LIFT-UP MECHANISM
- HORIZONTAL BI-FOLD DOOR MECHANISM
- SOFT CLOSING SYSTEM
- LID STAYS
- MULTI ANGLE LID STAYS
- SPRING LOADED LID STAYS
- DOOR HOLDERS



## DRAWER SLIDES

P. 266~

- STAINLESS STEEL DRAWER SLIDE
- ALUMINUM DRAWER SLIDE
- STEEL DRAWER SLIDE



## BRACKETS & HOOKS

P. 298~

- ANGLE BRACKETS
- FOLDING BRACKETS
- SHELF SUPPORTS & STANDARDS
- HOOKS
- RECESSED HOOKS
- FRAME HANGERS



## WARDROBE HARDWARE

P. 340~

- CLOSET ROD LIFT MECHANISM
- EXTENSION HANGERS
- SWINGING HANGERS



## SLIDING & FOLDING DOOR HARDWARE

P. 352~

- SLIDING DOOR HARDWARE
- SWING DOOR HARDWARE
- FOLDING DOOR HARDWARE
- FLUSH SLIDING DOOR HARDWARE
- MULTIPLE MOTION DOOR SYSTEM
- FLUSH SLIDING DOOR SYSTEM
- LATERAL OPENING DOOR SYSTEM



## GLASS HARDWARE

P. 432~

- GLASS DOOR HINGES
- GLASS DOOR LOCKS
- POINTFIX
- GLASS CLAMPS
- GLASS SHELF SUPPORTS
- SHOWER ROOM HARDWARE
- GLASS SLIDING DOOR HARDWARE



## SHELVING SYSTEM

P. 458~

- UNIT SHELF SYSTEM
- LEVEL ADJUSTABLE SHELVING SYSTEM
- WALL SHELVING SYSTEM



## LAVATORY HARDWARE

P. 488~

- PARTITION PANEL FITTINGS
- BABY HOLDING BEDS
- DRESSING STAGE
- MIRROR SUPPORTS



## CASTERS & LEVELING GLIDES

P. 504~

- TWIN WHEEL CASTERS
- DUAL BRAKE SYSTEM CASTERS
- SHOCK-ABSORBING CASTERS
- CASTER WITH LEVELING GLIDES
- LEVELING GLIDES
- SELF ADJUSTING LEVELING GLIDES



## LOCKS

P. 536~

- MILLION LOCKS
- CABINET LOCKS
- PUSH LOCKS
- MINI CAM LOCKS



## MISCELLANEOUS

P. 564~

- DOOR STOPPERS
- DOOR HOLDERS
- VENTILATORS
- CABLE GROMMETS
- MULTI PURPOSE LIDS
- DOOR CLOSERS
- LED LIGHTS



**LAMP**<sup>®</sup>



**SUGATSUNE**

**GLOBAL HEADQUARTERS:**

**SUGATSUNE KOGYO CO.,LTD.**

Tokyo JAPAN

E-mail : [export@sugatsune.co.jp](mailto:export@sugatsune.co.jp)  
[www.sugatsune-intl.com](http://www.sugatsune-intl.com)

**UK BRANCH:**

**SUGATSUNE KOGYO (UK) LTD.**

Reading UK

E-mail : [sales@sugatsune.co.uk](mailto:sales@sugatsune.co.uk)  
[www.sugatsune.co.uk](http://www.sugatsune.co.uk)