

PCU2 mk5

Primary Current Injection System

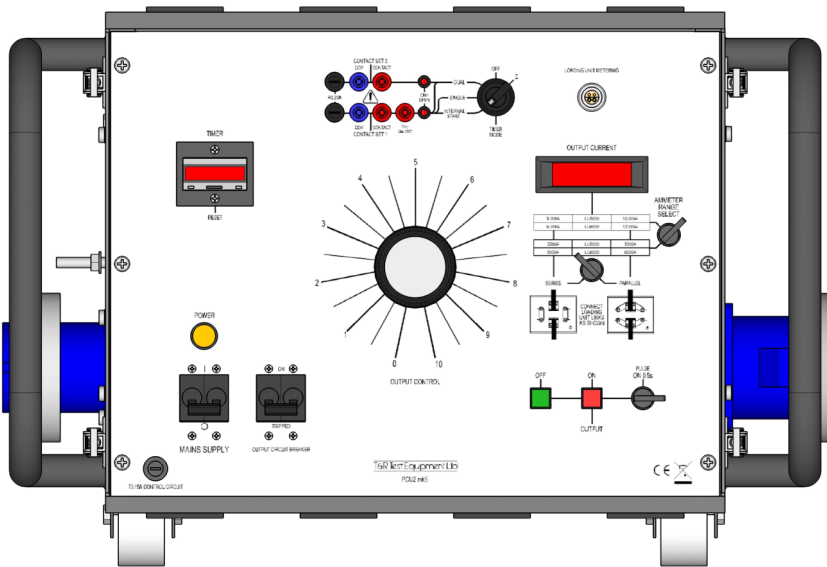

Features

- 20kVA 5 minute output capability
- Continuously variable output
- Multi-function timing system
- Digital true RMS memory ammeter
- Bright LED displays
- Automatic switch-off at end of test
- Centralised control and metering
- Separate control and loading units
- Output up to 10kA
- Low impedance, dual-range outputs

The PCU2 Mk5 primary current injection system is ideally suited to commissioning and maintenance testing where very high currents are required. The system consists of separate control and loading units for maximum flexibility. The control unit contains all control and metering circuitry, and is linked to the loading unit by control and metering cables.

The control unit may be used with one of two loading units providing between 5000A or 6000A for 5 minutes or up to 10 or 12kA for short periods. Each loading unit has two outputs which may be connected in series or parallel for maximum flexibility. For example, the LU6000 may be configured to either give a maximum current of 3000A at 6.6V or 6000A at 3.3V.

The control and loading units are each housed in tough steel cases fitted with castors and protective lifting handles. The loading units have a small plan area to allow them to be positioned as close as possible to the test object, minimising power requirements and maximising the available current.

The PCU2 Mk5 control unit is shown here with an LU5000 loading unit. This combination may be used to inject currents of up to 5000A for 5 minutes, 8000A for 5 seconds or 10000A for 1 second.

This unit is ideally suited to all primary current injection tasks, including testing under and over current relays, circuit breakers and CT ratio testing.

The control unit is rated at 20kVA and has digital metering. A memory facility is provided on the metering to hold the current reading when the output trips or is switched off. The current is automatically switched off when the device under test trips.

A flexible timing system is provided, allowing timing tests to be carried out to a resolution of 1ms. Selection for normally open or normally closed contacts is automatic, and the status of the contacts is shown on the front panel. Timing modes are available to test under and overcurrent devices, reclosers, under and over voltage devices, current trips and circuit breakers.

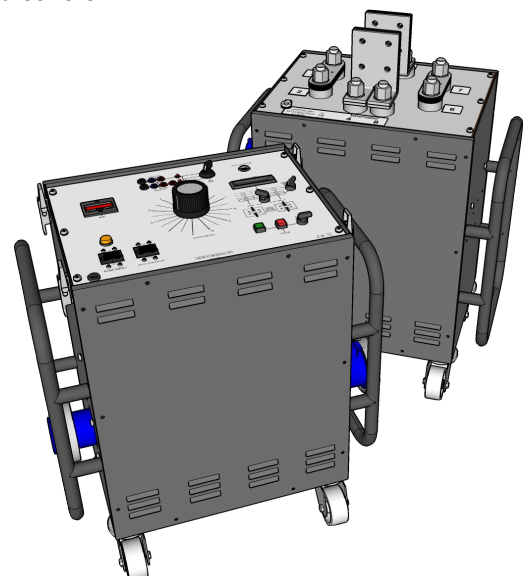

PCU2 mk5 System Specification

Metering

The AC output current is metered by a true RMS 4 digit memory ammeter with an LED display.

		Parallel mode	Series mode
Range 1	Full scale	5000A	2500A
	Resolution	1A	1A
	Accuracy	0.6% rdg+6d	0.6% rdg+6d
	Current trip	5500A	2750A
Range 2	Full scale	10.00kA	5.00kA
	Resolution	0.01kA	0.01kA
	Accuracy	0.6% rdg+6d	0.6% rdg+6d
	Current trip	11000A	5500A

Memory ammeter acquisition time 200ms

Loading Unit Output

The output of the loading unit is continuously variable from zero. Each unit may be operated in series/parallel mode to allow for a greater range of load impedances. All metering and tripping functions are handled by the control unit.

		LU5000		LU6000	
		Parallel mode	Series mode	Parallel mode	Series mode
Continuous	Open circuit V	0-4V	0-8V	0-3.3V	0-6.6V
	Current	2500A	1250A	3000A	1500A
	Max kVA	10	10	10	10
5 min on/ 15 min off	Current	5000A	2500A	6000A	3000A
	Max kVA	20	20	20	20
5 sec on	Current	8000A	4000A	9600A	4800A
	Max kVA	32	32	32	32
1 sec on	Current	10000A	5000A	12000A	6000A
	Max kVA	40	40	40	40

Protection and Safety

The PCU2 mk5 and loading units are CE marked and are designed to meet the requirements of BS EN61010.

The system is protected by a circuit breaker and fuse on the mains input, a circuit breaker on the loading unit output and an electronic trip on the output.

Supply Requirements

230V±10% 49-61Hz 1ph 23kVA 5 min/46kVA 1s

Temperature Range

Storage -20°C to 60°C, Operating 0°C to 45°C

Timing System

The PCU2 mk5 has a flexible timing system with two contact inputs and 5 operating modes. Both the start and stop contact circuits will accept volt free contacts. Each contact circuit automatically selects for N/O or N/C contacts, and the status of each contact input is shown by an LED. In addition to contact operation, the first timing channel may be triggered by a dc voltage between 24 and 240V. The timing system will also respond to the rise and fall of current in the test object for devices where no auxiliary contact is available. A pulse mode is also provided to allow injection for short periods (500ms) to avoid unnecessarily heating thermal trips.

Timer resolution	1ms	
Timer full scale	999.999s	
Timer accuracy	±0.01%rdg+2d	
	±0.01%rdg+3d current operated mode	
Contact O/C voltage	24V	
Contact S/C current	100mA	
Vdc input range	24-240Vdc	
Timer mode	Timer start	Timer stop
Normal	'On' button	Contact
Single contact	Contact 1	Contact 1
Dual contact	Contact 1	Contact 2
Current	Current >20% of range	Current <20% of range
Off	Timer inactive	

Accessories supplied with system

Spare fuse set, operating manual.

1 x 5m loading unit power interconnection lead.

1 x 5m loading unit metering interconnection lead.

1 x 2m mains lead

Unit	Dimensions	Weight
Control unit	660 x 400 x 740mm	115kg
LU5000	660 x 400 x 740mm	155kg
LU6000	660 x 400 x 740mm	135kg

Optional Output Lead Set Specifications

A range of output lead sets are available to complement the PCU2 mk5 system with current ratings between 3000A and 6000A. The leads are double insulated and have good flexibility.

Type	Length	CSA	Termination
3000AL	2.5m	560mm ²	Copper bar
4000AL	2.5m	700mm ²	Copper bar
5000AL	2m	840mm ²	Copper bar
6000AL	2m	1120mm ²	Copper bar

Other output lead lengths are available on request.

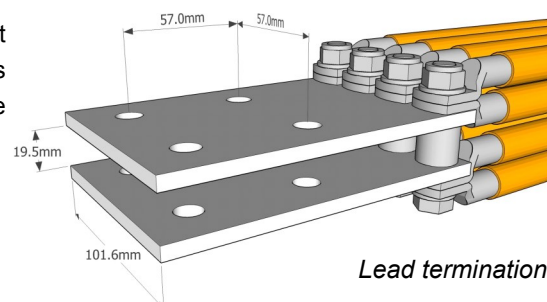

Lead termination

Note: Due to the company's continuous research programme, the information above may change at any time without prior notification. Please check that you have the most recent data on the product.

T&R Test Equipment Ltd, 15-16 Woodbridge Meadows, Guildford, Surrey, GU1 1BJ, UK

Tel: +44 (0)1483 207428 Fax: +44 (0)1483 511229 email: sales@trtest.com