

APPLICATION NOTE

The following are typical applications for testing relays, CT's and circuit breakers when using the 200ADM-P. Depending upon the test equipment model some functions below may not be possible. Please consult the manual of your product.

Contents

1	Over-current and earth fault relays	2
1.1	Pick-up and drop-off test	2
1.2	Timing test	3
1.3	Timing test with recording of results.....	4
1.4	Drop-off test with timing.....	5
2	Under-current relays	6
2.1	Pick-up and drop-off test	6
3	Under and over-voltage relays.....	7
3.1	Pick-up and drop-off test	7
3.2	Timing of over-voltage relays	8
3.3	Timing of under-voltage relays	9
4	Under and over frequency relays.....	11
4.1	Pick-up and drop-off test	11
4.2	Timing test	12
5	Auto reset/re-closing devices.....	13
5.1	Timing a single re-close action with circuit breaker	13
5.2	Procedure to time auto re-closing relay	14
6	Timing circuit breakers.....	16
7	Directional overcurrent/earth fault relays.....	17
8	Bias differential relays.....	19
9	Check sync relays.....	20
10	Current transformer magnetisation curves	22
11	Testing induction disk relays using the optional filter	24
12	Induction disk relay run-back time	25

1 Over-current and earth fault relays

1.1 Pick-up and drop-off test

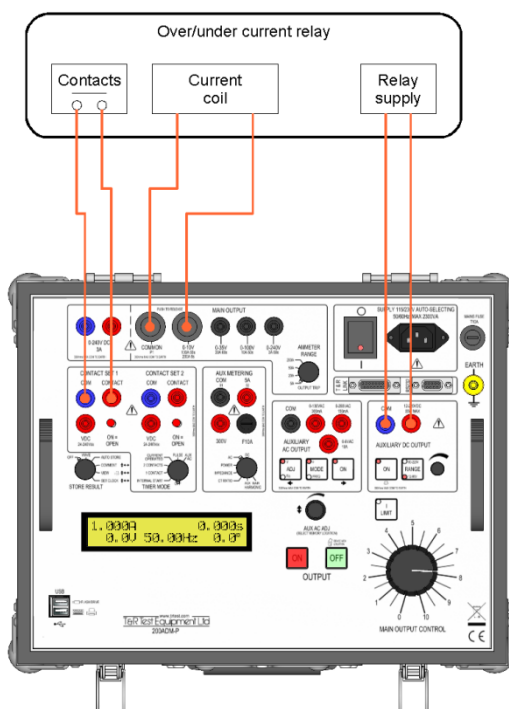

Figure 3.1 Connections for current pick-up/drop-off test (no storage)

Ammeter range	Select as required	Main output on/off	On
Store result	Off	I limit	On for current <10A
Timer mode	Off	Aux ac output adj	n/a
Aux metering	n/a	Aux ac output mode	n/a
Aux dc voltage	As required for relay	Aux ac output on/off	n/a

Procedure

1. Set main current output control to zero (anti-clockwise).
2. Switch on main current output.
3. Increase the main output current until the relay trips. The relay contact state is shown on the contact 1 LED. Record the current at which the relay tripped.
4. To find the drop-off point, reduce the current until the relay contacts reset. Record the drop-off current.

1.2 Timing test

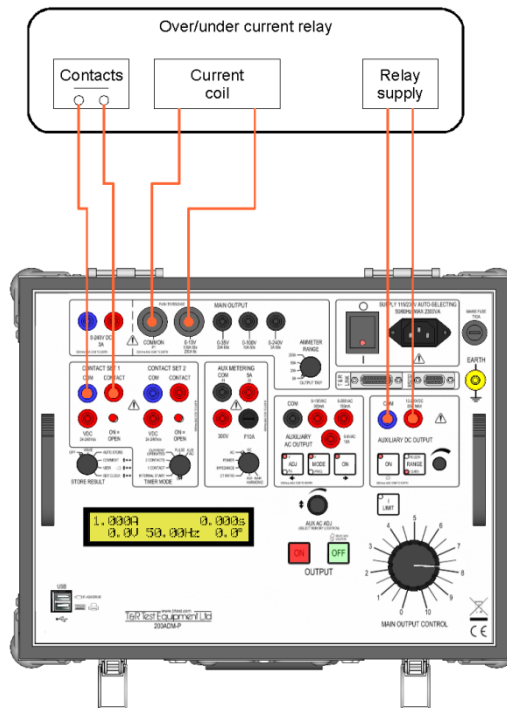

Figure 3.2 Connections for over-current timing

Ammeter range	Select as required	Main output on/off	On
Store result	Off	I limit	On for current <10A
Timer mode	Internal start	Aux ac output adj	n/a
Aux metering	n/a	Aux ac output mode	n/a
Aux dc voltage	As required for relay	Aux ac output on/off	n/a

Procedure

1. Set main current output control to zero (anti-clockwise).
2. Set TIMER MODE to OFF.
3. Switch on main current output.
4. Set the required test current and switch the output off.
5. Set TIMER MODE to INTERNAL START.
6. Switch on main output current. The output will come on and the timer will start.
7. When the relay trips the timer will stop and the output will switch off.
8. Repeat steps 2 to 7 for other test currents as required.

1.3 Timing test with recording of results

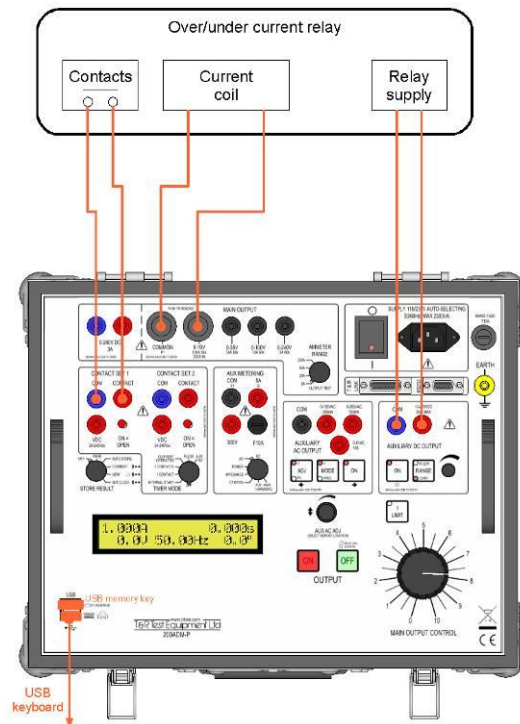

Figure 3.3 Connections for overcurrent timing

Ammeter range	Select as required	Main output on/off	On
Store result	Auto-store	I limit	On for current <10A
Timer mode	Internal start	Aux ac output adj	n/a
Aux metering	n/a	Aux ac output mode	n/a
Aux dc voltage	As required for relay	Aux ac output on/off	n/a

Procedure

1. Ensure USB memory key is inserted in USB socket if result storage is required. Enter a comment for the test using the USB keyboard (Set STORE RESULT to COMMENT).
 2. Set STORE RESULT to AUTO-STORE.
 3. Set main current output control to zero (anti-clockwise).
 4. Set TIMER MODE to OFF.
 5. Switch on main current output.
 6. Set the required test current and switch the output off.
 7. Set TIMER MODE to INTERNAL START.
 8. Switch on main output current. The output will come on and the timer will start.
 9. When the relay trips the timer will stop and the output will switch off.
- Repeat steps 4 to 10 for other test currents as required.

1.4 Drop-off test with timing

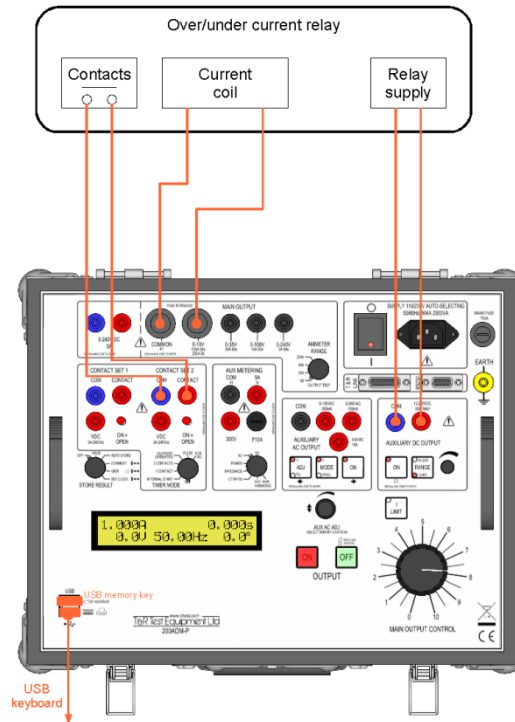

Figure 3.4 Connections for current drop-off test (with storage of result)

Ammeter range	Select as required	Main output on/off	On
Store result	Auto-store	I limit	On for current <10A
Timer mode	Single contact Use contact set 2	Aux ac output adj	n/a
Aux metering	n/a	Aux ac output mode	n/a
Aux dc voltage	As required for relay	Aux ac output on/off	n/a

Procedure

Note: Contacts connected to contact set 2 (see section 1.3.6 for details of contact modes). If connected to contact set 1 the output will switch off after the first contact set change.

1. Set main current output control to zero (anti-clockwise).
2. Switch on main current output.
3. Increase the main output current until the relay picks up.
4. Switch off the output using the OFF switch.
5. The output will switch off and the timer will start. The timer will stop when the relay drops out.

2 Under-current relays

2.1 Pick-up and drop-off test

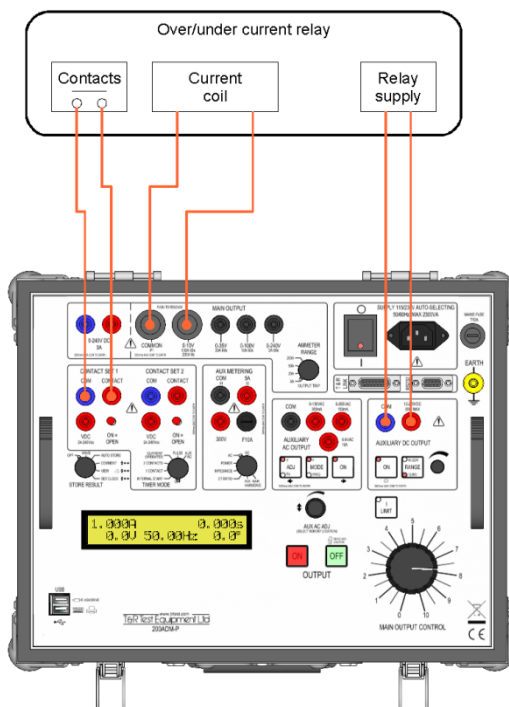

Figure 3.5 Connections for current pick-up/drop-off test (no storage)

Ammeter range	Select as required	Main output on/off	On
Store result	Off	I limit	On for current <10A
Timer mode	Off	Aux ac output adj	n/a
Aux metering	n/a	Aux ac output mode	n/a
Aux dc voltage	As required for relay	Aux ac output on/off	n/a

Procedure

1. Set main current output control to zero (anti-clockwise).
2. Switch on main current output.
3. Increase the main output current until the current is higher than the relay setting. The relay should now reset.
4. Decrease the current until the relay trips. This is the pick-up value.
5. Increase the current until the relay resets. This is the drop-off value.

3 Under and over-voltage relays

3.1 Pick-up and drop-off test

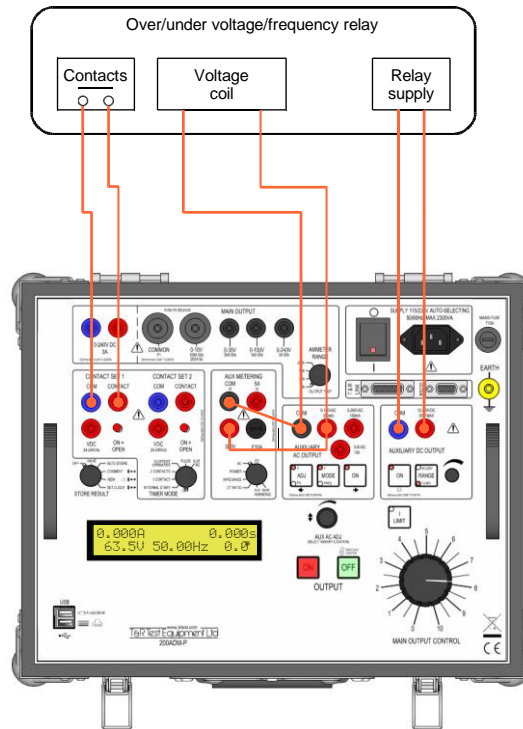

Figure 3.6 Connections for pick-up/drop-off test

Ammeter range	n/a	Main output on/off	On
Store result	Off	I limit	Off
Timer mode	Off	Aux ac output adj	n/a
Aux metering	AC	Aux ac output mode	n/a
Aux dc voltage	As required for relay	Aux ac output on/off	n/a

Procedure

1. Switch on auxiliary ac output.
2. Increase the auxiliary ac voltage until the relay trips. The voltage is measured using the auxiliary metering and shown on the bottom line of the display. The relay contact state is shown on the contact 1 LED. Record the voltage at which the relay tripped.
3. To find the drop-off point, reduce the voltage until the relay contacts reset. Record the drop-off voltage.
4. For an under voltage relay start above the trip voltage and reduce to find the pick-up point, then increase to find the drop-off voltage.

3.2 Timing of over-voltage relays

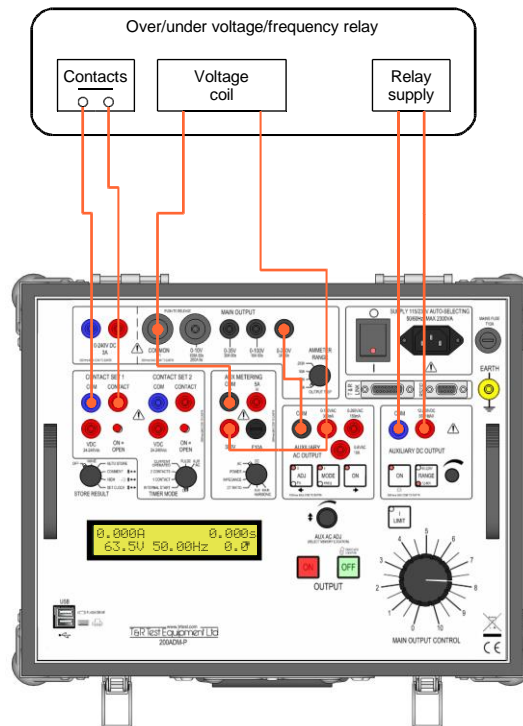

Figure 3.7 Over-voltage with timing

Ammeter range	n/a	Main output on/off	On
Store result	n/a	I limit	Off
Timer mode	Aux ac	Aux ac output adj	V
Aux metering	RMS	Aux ac output mode	Φ
Aux dc voltage	If required by relay	Aux ac output on/off	On

Over-voltage pickup time

1. Set the output control to zero.
2. Switch the main output on and increase the voltage to the relay nominal voltage, V_n .
3. Switch the auxiliary ac output on, and increase the output voltage until the total voltage is at the required level to trip the relay.
4. Switch both outputs off.
5. Switch the main output on and wait for the relay to settle.
6. Switch the auxiliary ac output on. The timer will start when the voltage step is applied, and stop when contact set 1 changes state.
7. Switch the output off after testing.

Over-voltage dropout time

1. Leave the controls set from the pickup test.
2. Switch the auxiliary ac output on.
3. Switch the main output on. This arms the timer.

4. Switch the auxiliary ac output off. The timer will start when the aux ac switches off, and stop when contact set 1 changes state.
5. Switch the outputs off after testing.

3.3 Timing of under-voltage relays

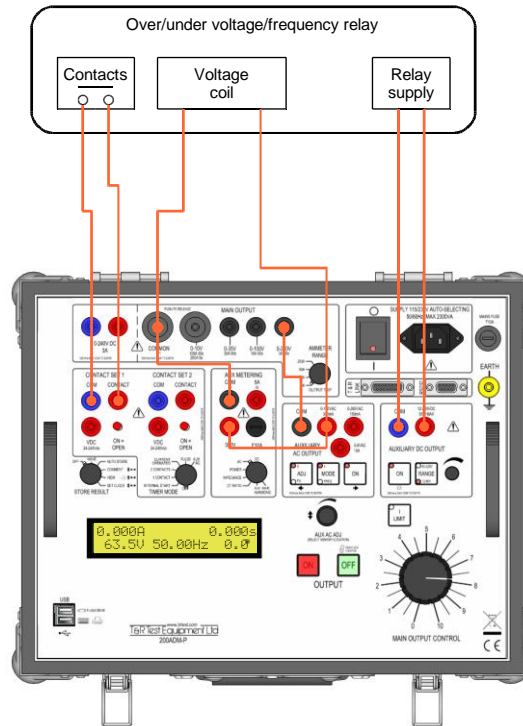

Figure 3.8 Under-voltage with timing

Ammeter range	n/a	Main output on/off	On
Store result	n/a	I limit	Off
Timer mode	Aux ac	Aux ac output adj	V
Aux metering	RMS	Aux ac output mode	Φ
Aux dc voltage	If required by relay	Aux ac output on/off	On

Under-voltage pickup time

1. Set the output control to zero.
2. Switch the main output on and increase the voltage to a voltage below V_n that will trip the relay.
3. Switch the auxiliary ac output on, and increase the output voltage until the total voltage is V_n .
4. Switch both outputs off.
5. Switch the auxiliary ac output on.
6. Switch the main output on. This arms the timer.
7. Switch the auxiliary ac output off. The timer will start when the aux ac switches off, and stop when contact set 1 changes state.
8. Switch the outputs off after testing.

Under-voltage dropout time

1. Leave the controls set from the pickup test.
2. Switch the main output on.
3. Switch the auxiliary ac output on. The timer will start and then stop when the relay drops out.

4 Under and over frequency relays

4.1 Pick-up and drop-off test

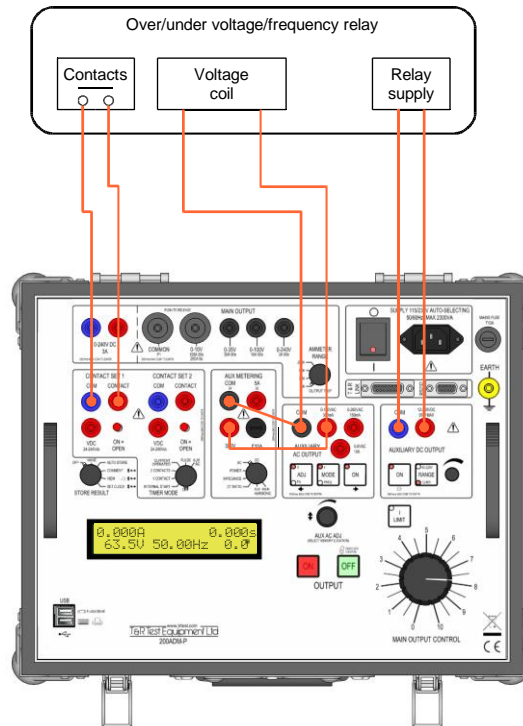

Figure 3.9 Connections for pick-up/drop-off test

Ammeter range	n/a	Main output on/off	Off
Store result	Off	I limit	n/a
Timer mode	Off	Aux ac output adj	V then F/Φ
Aux metering	AC	Aux ac output mode	f
Aux dc voltage	As required for relay	Aux ac output on/off	On

1. Switch on the aux ac output. Select V using adj button.
2. Increase the voltage using the AUX AC ADJ control to the relay operating voltage.
3. Press ADJ to select F/Φ, and press MODE button to select FREQ.
4. For an over-frequency relay increase the frequency using the AUX AC ADJ control until the relay trips. The relay contact state is shown on the contact 1 LED. Record the pick-up frequency.
5. Reduce the frequency until the relay resets. Record the drop-off frequency.
6. For an under-frequency relay decrease the frequency using the AUX AC ADJ control until the relay trips. The relay contact state is shown on the contact 1 LED. Record the pick-up frequency.
7. Increase the frequency until the relay resets. Record the drop-off frequency.

4.2 Timing test

Ammeter range	n/a	Main output on/off	On (to arm timer)
Store result	Off	I limit	n/a
Timer mode	AUX AC	Aux ac output adj	V then F/ Φ
Aux metering	AC	Aux ac output mode	f
Aux dc voltage	As required for relay	Aux ac output on/off	On

The output frequency of the auxiliary output can be switched between supply frequency (Φ) and variable frequency (FREQ) using the MODE button. This procedure uses this to switch between two frequencies to time the operation of over or under frequency relays.

1. Connections as for pick-up/drop-off test as figure 3.9.
2. Switch on the aux ac output. Select V using ADJ button.
3. Increase the voltage using the AUX AC ADJ control to the relay operating voltage.
4. Press ADJ to select F/ Φ , and press MODE button to select FREQ.
5. Increase the frequency (for an over-frequency relay) using the AUX AC ADJ control to a value that will definitely trip the relay – you will see the relay trip as the frequency is increased. For an under-frequency relay set a frequency lower than the supply frequency.
6. Press MODE to select Φ . This selects supply frequency.
7. Reset the relay.
8. Ensure that TIMER MODE is set to AUX AC. Switch the main output ON to arm the timer.
9. Press MODE to select FREQ. The frequency is set to the frequency set in step 4, and the timer starts.
10. The timer stops when contact set 1 changes.
11. Switch the outputs off after testing.

5 Auto reset/re-closing devices

Auto re-closing devices require that the timer is started when power is removed from the device, and the timer stops when the contacts change state. Using the 200ADM-P, it is possible to time either the first re-close operation only or a complete series of re-closing actions.

5.1 Timing a single re-close action with circuit breaker

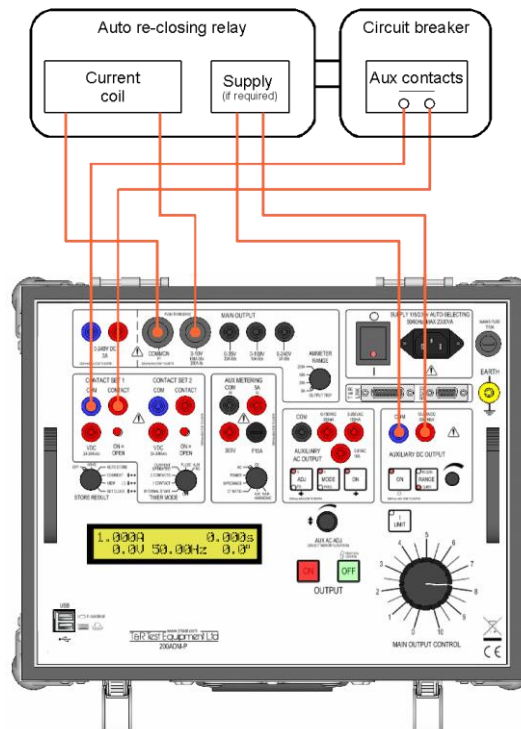

Figure 3.10 Connections for testing auto-reclose relay and circuit breaker

Ammeter range	Select as required	Main output on/off	On
Store result	Off	I limit	On for I<10A
Timer mode	1 Contact Contact set 1	Aux ac output adj Aux ac output mode Aux ac output on/off	Both LEDs off n/a n/a
Aux metering	Dc , ac, power, impedance, CT ratio. NOT harmonics.		
Aux dc voltage	As required for relay		

Procedure to time re-closing devices (single re-close with circuit breaker connected)

1. Set main output control to zero.
2. Set TIMER MODE to OFF.
3. Switch on main output and increase to desired test current.
4. Switch off main output and set TIMER MODE to 1 CONTACT.
5. Switch on main output by pressing the ON pushbutton briefly. The relay trips, starts the timer and switches off the output. The unit times between the first

contact change when the current is switched off and the second contact change.

5.2 Procedure to time auto re-closing relay

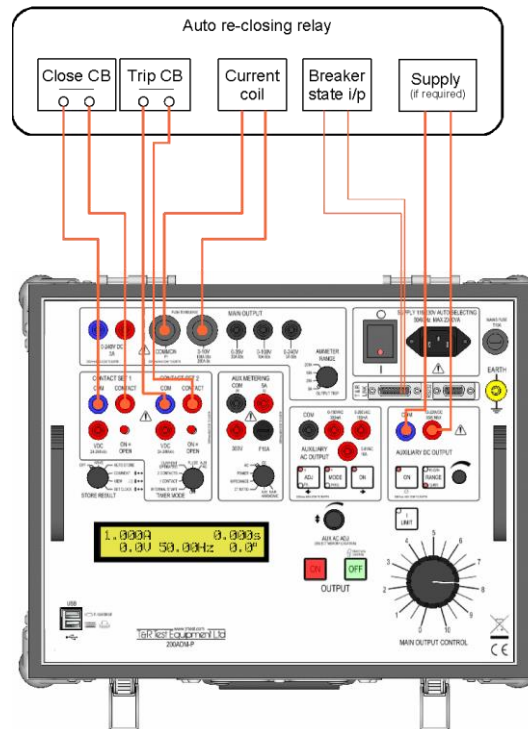

Figure 3.11 Connections for testing auto-reclose relay

Ammeter range	Select as required	Main output on/off	On
Store result	Off	I limit	On for I<10A
Timer mode	2 Contact	Aux ac output adj	Both LEDs off
Aux metering	Dc , ac, power, impedance, CT ratio. NOT harmonics.	Aux ac output mode	n/a
Aux dc voltage	As required for relay	Aux ac output on/off	n/a

Procedure to time auto re-closing relay

1. Set main output control to zero.
2. Set TIMER MODE to OFF.
3. Switch on main output and increase to desired test current.
4. Switch off main output and set TIMER MODE to 2 CONTACTS.
5. Ensure that the breaker close signal from the relay is connected to contact set 1 and the breaker trip contact is connected to contact set 2.
6. Start the test by pressing the ON pushbutton. The timer starts when the output is switched on.

7. On the 1st change of C2 (breaker trip contact) the timer result is stored as t0 (time to trip from inception of fault). The timer resets and restarts, and the output is switched off.
8. On the 1st change of C1 (breaker close contact) the timer result is stored as t1 (first re-close time). The output switches back on automatically, and the timer resets and restarts.
9. On the 2nd change of C2 (breaker trip) the timer result is stored as t2 (second trip time). The timer resets and restarts, and the output is switched off.
10. On the 2nd change of C1 (breaker close) the timer result is stored as t3 (second re-close time). The output switches back on automatically, and the timer resets and restarts.
11. This cycle continues until the OFF pushbutton is pressed. The display is left showing the last timer value. If auto-store mode is selected, all of the results for the test are written to the USB memory key, and if a printer is connected the results are printed. Up to 100 times can be recorded. After t99 is stored the test ends and the output switches off automatically.

At the end of the test the aux output ADJ knob is automatically put into timer result selection mode (both LEDs off). The ADJ knob scrolls through the timer results. The timer results are cleared when the output is switched on for another test.

See section 1.3.6.6 for further details and timing diagram.

If the re-closing relay requires a contact to indicate the breaker state this can be obtained from the T&R link connector (pins 9&10 close when the main output is on). An optional accessory T&R link contact lead may be used to make the connection (part number A219-0004). The two black leads are connected when the output is on.

6 Timing circuit breakers

Testing CBEs (circuit breakers for equipment) MCBs (miniature circuit breakers) and other devices with no auxiliary contacts is possible using the current operated timer mode on the 200ADM-P. This mode starts the timer when the output current exceeds 20% of the selected current range, and stops the timer when the current falls below 20% of range.

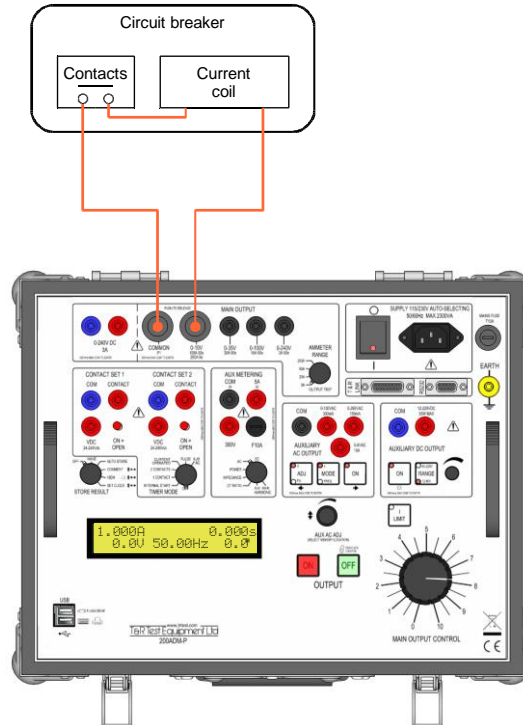

Figure 3.12 Connections for testing circuit breakers

Ammeter range	Select as required	Main output on/off	On
Store result	Off	I limit	Off
Timer mode	Current operated	Aux ac output adj	n/a
Aux metering	n/a	Aux ac output mode	n/a
Aux dc voltage	n/a	Aux ac output on/off	n/a

12. Set the current metering range so that the device trip current is >20% of the selected metering range.
13. Set main output to zero.
14. Set TIMER MODE to off
15. Switch the output on and increase the current to the desired test current. For thermal devices or devices with short trip times pulse mode can be used to set the current – current is injected for 200ms each time ON is pressed. Increase the current in stages until the desired current is reached.
16. Set TIMER MODE to CURRENT OPERATED.
17. Switch the output on. The timer will stop when the circuit breaker opens.

7 Directional overcurrent/earth fault relays

Testing a single phase directional relay requires one current and a phase-shifting voltage.

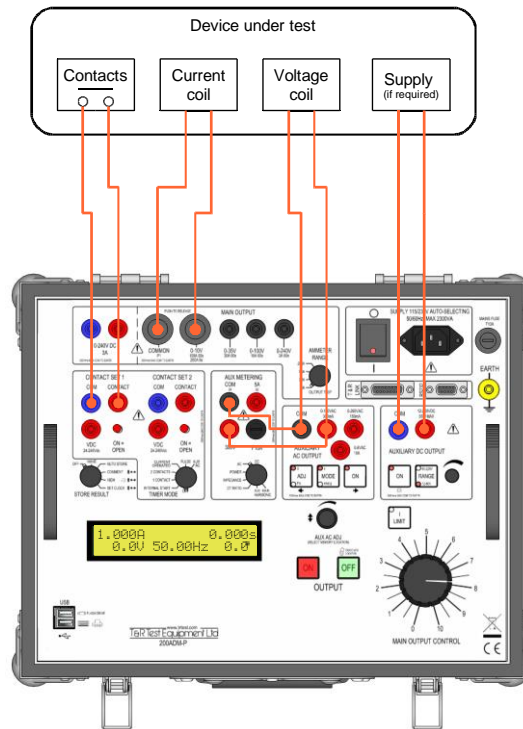

Figure 3.13 Connections for directional overcurrent relay

Ammeter range	As required	Main output on/off	On
Store result	n/a	I limit	On for I<10A
Timer mode	Internal start	Aux ac output adj	V
Aux metering	AC	Aux ac output mode	Φ
Aux dc voltage	If required by relay	Aux ac output on/off	On

Procedure for finding restraint angles

1. Set main current output control to zero (anti-clockwise).
2. Set TIMER MODE to OFF.
3. Switch on main current output and increase to relay I_n .
4. Switch on auxiliary voltage output and increase to relay V_n using AUX AC ADJ.
5. Press ADJ to switch to phase adjust mode (check that F/Φ and Φ LEDs are illuminated). The phase angle may now be rotated using AUX ADC ADJ.
6. Rotate the phase angle and monitor the directional element contact of the relay to see when the relay goes into restraint and comes out of restraint.

Note: To see the effect of the restraint angle immediately the contact input must be connected to a relay contact driven directly by the directional element. If this contact is not available, the overcurrent trip contact must be used, in which case the test current must be high enough to trip the relay and the overcurrent delay must be taken into account.

Procedure for overcurrent timing tests

1. Set the phase angle so the relay is out of restraint.
2. Leave the aux ac voltage switched on and set to this phase angle.
3. Conduct the timing test as detailed in section 3.1.2 or 3.1.3.

8 Bias differential relays

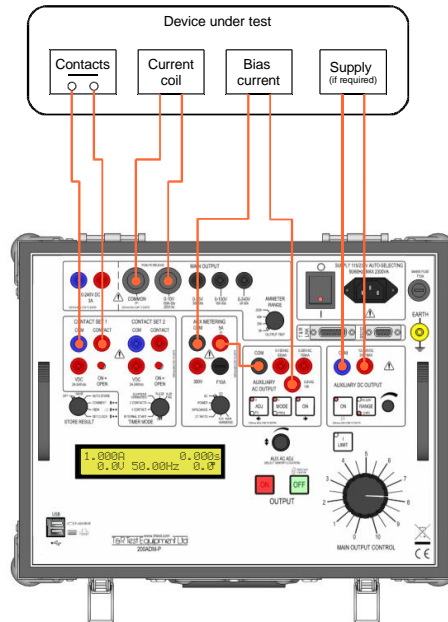

Figure 3.14 Connections for bias differential relays

Ammeter range	Select as required	Main output on/off	On
Store result	n/a	I limit	On for I<10A
Timer mode	Internal start/Aux ac	Aux ac output adj	V
Aux metering	RMS	Aux ac output mode	Φ
Aux dc voltage	If required by relay	Aux ac output on/off	On

Procedure

1. Switch on the aux ac output and increase the current to the required value for the bias coil.
2. Switch on main current output and increase the current to the differential coil until the relay trips.
3. The relay trip point can then be checked against to the relay bias curve.

9 Check sync relays

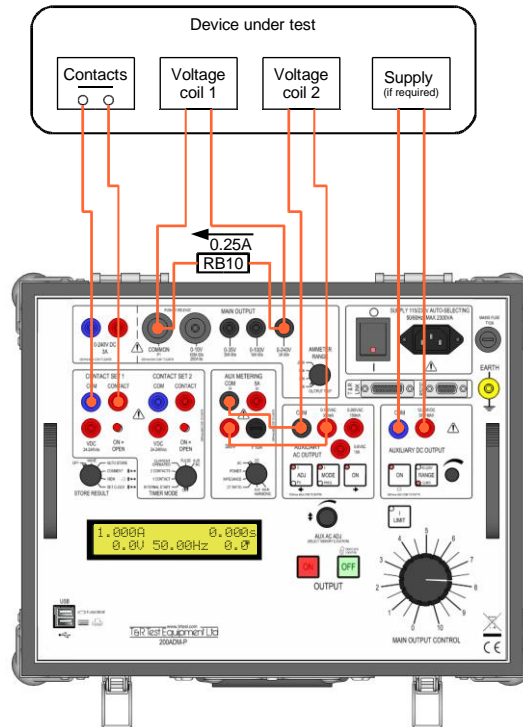

Figure 3.15 Connections for check-sync relay

Ammeter range	5A	Main output on/off	On
Store result	n/a	I limit	Off
Timer mode	Aux ac	Aux ac output adj	V
Aux metering	AC	Aux ac output mode	Φ
Aux dc voltage	If required by relay	Aux ac output on/off	On

Procedure

4. The optional RB10 resistor box is required for this test to draw enough current from the main output for the phase angle to be displayed (a minimum of 0.25A). The resistor on the RB10 should be chosen to draw 0.25-0.5A (eg 666Ω for 230V to give 0.345A).
5. Switch on the main output and set the voltage to V_n for the relay (temporarily move the aux metering input from the aux output to the main output to set the voltage).
6. Switch on the auxiliary ac output and set the voltage to V_n for the relay.
7. Press ADJ to switch to phase adjust mode (check that F/Φ and Φ LEDs are illuminated). The phase angle may now be rotated using AUX ADC ADJ.
8. The operation of the relay can now be checked by adjusting the phase angle and checking when the relay operates.

Continued...

9. The trip time of the relay can be checked by selecting F adjust mode and setting the frequency out of range for relay (e.g. 53Hz for a 50Hz relay). Pressing the MODE button will then toggle the output between mains frequency and the set frequency. When the main output is on, the timer starts when the MODE button is pressed (i.e. when the frequency changes) and stops on a change of contact set 1. Reset the timer by switching the main output off and back on again.

10 Current transformer magnetisation curves



Ensure that the CT primary is open circuit and the secondary side is not connected to any other circuit.

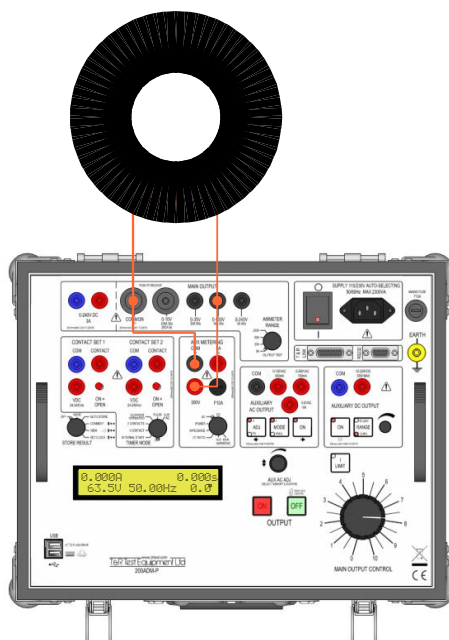

Figure 3.16 Connection of for CT mag curve

Ammeter range	5A	Main output on/off	On
Store result	Auto store	I limit	Off
Timer mode	Off	Aux ac output adj	N/A
Aux metering	AC	Aux ac output mode	N/A
Aux dc voltage	Off	Aux ac output on/off	Off

Procedure (manual recording of results)

1. Switch output on and increase voltage until knee point of CT is exceeded. Reduce voltage to desired level for first (highest) result.
2. Record voltage and current.
3. Decrease voltage for next test and repeat for other voltages as required.
4. Reduce output voltage to zero before switching off.

Procedure (automatic recording of results)

1. Enter comment if required using USB keyboard.
2. Set STORE RESULT to AUTO STORE.
3. Set timer to off.

4. Switch output on and increase voltage until knee point of CT is exceeded. Reduce voltage to desired level for first (highest) result.
5. Press the ON pushbutton to force recording of result. The display shows s01 to indicate that the first result has been stored. The result is stored internally, and all results will be written to the USB memory key when the output is switched off.
6. Decrease voltage for next test, press ON to record the result (s02 displayed). Repeat for other voltages as required.
7. Reduce output voltage to zero before switching off. When the output is switched off, all results will be written to the memory key. The resulting CSV file on the memory key may then be opened in a spreadsheet and an x-y graph plotted of the magnetisation curve.

11 Testing induction disk relays using the optional filter

When testing inductive disk type relays, the current waveform is distorted by the relay, and timing results will be inaccurate. In this situation it is necessary to use the T&R Test Equipment 100ADM-F filter unit to force the current to a sinusoid. This unit is an optional accessory.

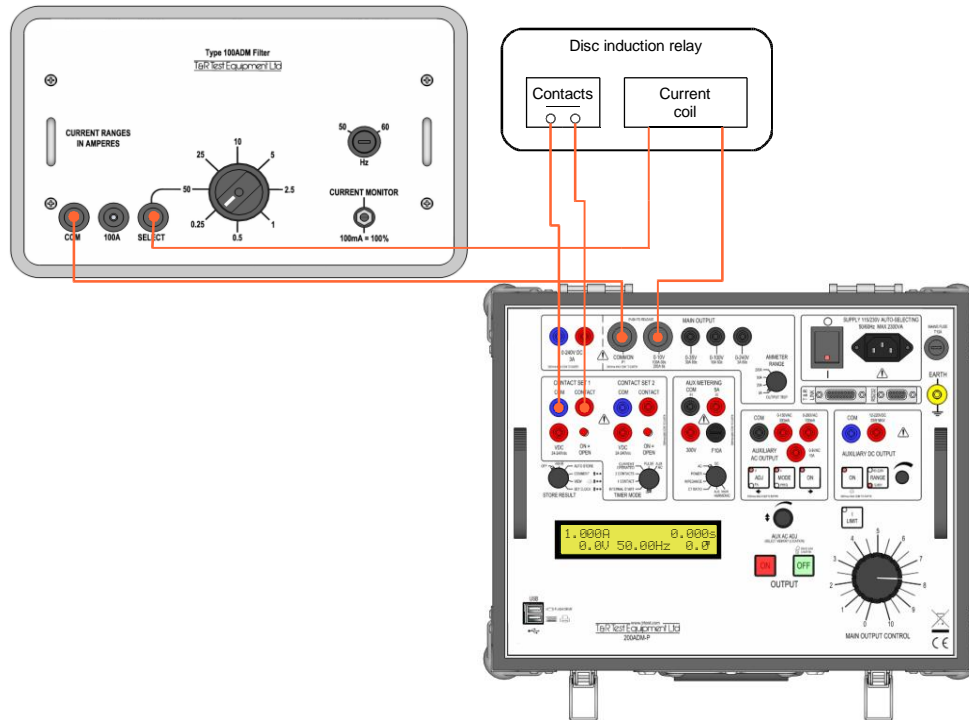

Figure 3.17 Connection of filter unit and inductive disc relay

12 Induction disk relay run-back time

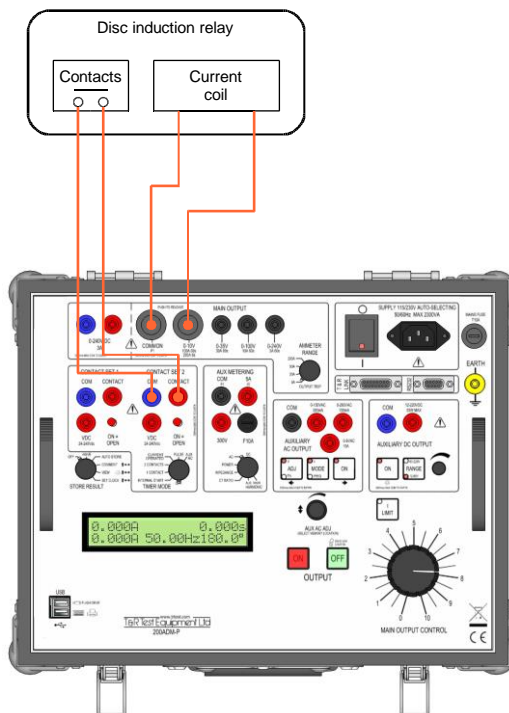

Figure 3.18 Connections for run-back timing

Ammeter range	Select as required	Main output on/off	On
Store result	Off	I limit	On for current <10A
Timer mode	2 contact	Aux ac output adj	n/a
Aux metering	n/a	Aux ac output mode	n/a
Aux dc voltage	As required for relay	Aux ac output on/off	n/a

Procedure

1. Set main current output control to zero (anti-clockwise).
2. Set TIMER MODE to OFF.
3. Switch on main current output.
4. Set the required test current and switch the output off.
5. Set TIMER MODE to 2 CONTACTS.
6. Switch on main output current. The output will come on and the timer will start.
7. When the relay trips the timer result is stored as t0. The output switches off and the timer restarts.
8. The disk will return to its reset position. When it comes to rest, press the OFF button (the accuracy of the test depends on pressing the off button at the moment the disk comes to rest). The timer result is stored as t2.

At the end of the test the AUX AC ADJ knob is automatically put into timer result selection mode (both LEDs off). The AUX AC ADJ knob selects the display of t0 (relay trip time) and t1 (run-back time). The timer results are cleared when the output is switched on for another test.

