

**TBA**



Protective Solutions

**EMI SHIELDING**

# EMI SHIELDING FINGER STRIP



# Beryllium Copper Shielding

Beryllium copper finger stock provides maximum spring properties for strength and fatigue resistance, plus excellent conductivity. It comes in a variety of finishes and mounting styles including **Clip-on, Stick-on, Snap-on and Special Mounting**.

Beryllium copper's unique material properties make it ideal for RFI/EMI shielding. Available with numerous plating options, BeCu has a high cycle time and also conforms to large gap variations.

## Standard Products

TBA-PS offers the most complete line of standard BeCu shielding strips in the industry. Uncompressed heights of standard finger stock range from 0.76mm to 11.2mm, which will occupy gaps as low as 0.25mm. A line of standard connector gaskets is also available.

## Custom Shielding

- Board Level Shielding
- Connector Gaskets

Semi-standard and custom designed shielding is offered for special applications such as board level shielding and connector gaskets. From high volume requirements using progressive dies, to prototype and low quantities utilising photoetch fabrication, TBA-PS can be your source for custom beryllium copper shielding.

- **NO-SNAG SERIES**

*Eliminates finger damage and snagging*

- **SOFT NO-SNAG SERIES**

*Low compression forces and self cleaning*

- **SYMMETRICAL SERIES**

*Bi-directional sliding contact*

- **PANEL GASKET SERIES**

*Can be compressed to stock thickness*

- **FOUR INSTALLATION OPTIONS**

*Design flexibility*

- **CONTROLLED CONTACT RESISTANCE**

*Consistent attenuation over time*

- **RANGE OF SHAPES AND SIZES**

*Custom fit at a standard cost*

## Use BeCu Because . . .

- Excellent spring qualities
- Longevity
- Low closing force
- Cost effective
- Numerous plating options
- Conforms to large gap unevenness
- Attenuation exceeding 100 db for most styles

TBA100

## Table of Contents

|  |       |
|--|-------|
| • Material Specification and General Information .....   | 2-5   |
| • D-Sub Miniature Connector Gaskets .....  | 6     |
| • Pressure Sensitive Mounting (Soft Fingers, No Snag Fingers, Panel Gaskets) .....                     | 7-10  |
| • Low Profile & Hook-On Gaskets .....  | 11-12 |
| • Snap-on Mountings (Slot Mount, Track, Omni) .....  | 13-17 |
| • Clip-on Mounting (Twisted Contacts, No Snag Fingers, Cylindrical Radius Reverse Bend Contacts) . . . | 17-20 |
| • Special Mounting (Reverse Bend, Spherical and Cylindrical Radius Contact Strip Gaskets) .....        | 21-24 |
| • Contact Rings .....  | 25    |

## How to Order

- Each profile has its own unique number.
- Strips may be supplied as a standard length or custom cut to any length, provided that length is a multiple of a full finger.
- The fingerstock is normally supplied as clean and bright finish, other plating options are available, and designated with a part number suffix.
- Clip-On Gaskets may be supplied with a retaining D-Lance, and designated with a suffix L.
- Clip on gaskets may have different flange thickness, designated by suffix A, B, C etc.
- Low force compression options can be supplied designated by the prefix LC.

## Examples

|               |  |
|---------------|--|
| ECP 645       | (pressure sensitive soft finger).                            |
| ECP 645/100mm | (do cut to 100mm).   |
| ECP 645/02    | (clean + bright).  |
| ECP 645/08    | (tin plated).  |
| ECP 643/L/08  | (lanced + tin plated).                                       |
| ECP 672A/L    | (Flange thickness 1.17mm with lances).                       |
| LC/ECP 615    | (produced in 0.05mm strip instead of 0.09mm thick material). |
| ECP 25 D10    | (25 Way D-Sub Connector in Stainless Steel).                 |
| ECP 25 D12/08 | (25 Way D-Sub Connector in tin plated Becu).                 |

This catalogue relates to the material as supplied. The information contained herein is given in good faith, but no liability will be accepted by the Company in relation to same. The acquisition of additional information may necessitate revisions to parts or all of this Catalogue, and such information will be supplied as it becomes available.

As the company's products are used for a multiplicity of purposes, and as the Company has no control over the method of their application or use, the Company excludes all conditions or warranties, express or implied, by statute or otherwise, as to their products and/or their fitness for any particular purpose.

Any technical co-operation between the Company and the Customer is given for the Customer's assistance only and without liability on the part of the Company.



## Material Specifications

Beryllium copper alloy 25 (CA172) is used in these applications for maximum spring properties of strength and fatigue resistance. Consult us for high temperature applications.

### Chemical Composition

|                              |            |
|------------------------------|------------|
| Beryllium                    | 1.80–2.00% |
| Cobalt plus nickel           | 0.20% Min. |
| Cobalt plus nickel plus iron | 0.6% Max.  |
| Copper                       | Balance    |

### Physical Properties (heat treated)

|                                  |        |
|----------------------------------|--------|
| Electrical conductivity (% IACS) | .22–25 |
| Modulus of elasticity (GPa)      | 127.5  |

### Mechanical Properties (heat treated)

|                                 |           |
|---------------------------------|-----------|
| Temper                          | ½HT       |
| Tensile strength (MPa)          | 1275 Min. |
| Yield strength .2% offset (MPa) | 160 Min.  |

### Manufacturing Tolerances (mm)

|               |        |
|---------------|--------|
| Pitch         | ±0.127 |
| Length        | ±1.52  |
| Spring Height | ±0.51  |
| Cut Length    | ±0.51  |

### Finish

Finger Strips are stocked with a clean and bright finish. 02 finish standard

Other finishes available are:

|                                 |     |
|---------------------------------|-----|
| Solderable unplated             | .01 |
| Clean and Bright (unsolderable) | .02 |
| Gold                            | .03 |
| Silver                          | .04 |
| Tin Lead                        | .07 |
| Bright Tin                      | .08 |
| Bright Nickel                   | .09 |
| Zinc/Clear Chromate             | .15 |
| Electroless Nickel              | .18 |
| Other                           | .00 |

For other requirements and specifications of these finishes, consult us.

## Electrochemical Compatibility

To avoid galvanic action between contacting metals refer to the following chart. Materials in adjacent groups may be safely used together. Choosing materials from within a single group in the table will provide the least corrosion due to galvanic action, when the materials are in contact for an extended period of time with appropriate protective finish.

### GROUPING OF METALS BY DECREASING GALVANIC ACTIVITY

ANODIC

| Group 1             | Group 2                 | Group 3                 | Group 4                |
|---------------------|-------------------------|-------------------------|------------------------|
| Magnesium           | Aluminium               | Cadmium Plating         | Brass                  |
| Magnesium Alloys    | Aluminium Alloys        | Carbon Steel            | Stainless Steel        |
| Aluminium           | Beryllium               | Iron                    | Copper & Copper Alloys |
| Aluminium Alloys    | Zinc & Zinc Plating     | Nickel & Nickel Plating | Nickel/Copper Alloys   |
| Beryllium           | Chromium Plating        | Tin & Tin Plating       | Monel                  |
| Zinc & Zinc Plating | Cadmium Plating         | Tin/Lead Solder         | Silver                 |
| Chromium Plating    | Carbon Steel            | Brass                   |                        |
|                     | Iron                    | Stainless Steel         |                        |
|                     | Nickel & Nickel Plating | Copper & Copper Alloys  |                        |
|                     | Tin & Tin Plating       | Nickel/Copper Alloys    |                        |
|                     | Tin/Lead Solder         | Monel                   |                        |

CATHODIC

## Attenuation Management

The purpose of shielding is to occupy and thereby shield the gap that exists between two adjoining surfaces. In order to be effective the gasket must be able to compensate for gaps which exist due to fabrication tolerances, misalignment of surfaces or irregular surfaces. Proper compression management is essential to ensure effective EMI shielding, for example at the maximum gap the gasket should be compressed in excess of 50% if needed. Attenuation exceeding 100dB for most styles can therefore be achievable.

## Compression Management

Fingerstock can be compressed to a maximum deflection of 90% of the free height of the spring. It is generally recommended that a minimum of 25% compression is used to enable good electrical contact. The compression forces which result through this range are given in the performance data for each spring. Many of the springs are available in low compression material (designated LC in the data) and are used in applications where the closure force between the mating surfaces needs to be minimised.

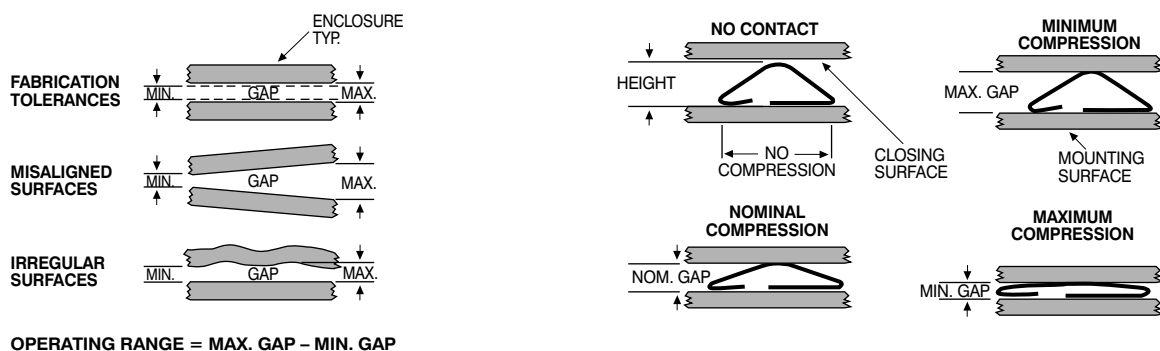

## Application Guide

- The **Installation Options** guide (see page 5) details how the springs can be fitted to the panelwork.
- Select a spring which can give around 50% compression in sealing the gap between the surfaces for optimum performance. The choice of the largest gasket to meet this gap filling requirement generally ensures that minimum compression forces are obtained, the use of larger gaskets also allows for greater tolerance latitude in the panelwork construction. Selection for minimum compression force also minimises the chance of panel deformation and the subsequent increased cost and use of stiffening members.
- The springs naturally act in a sliding or shear mode on compression. This wiping action ensures that good electrical continuity is maintained, the harder spring surface cleans any build up of oxidation corrosion or contamination on the mating surface.
- The springs should be mounted in a manner which avoids damage to the fingers. When the spring is used in a sliding or shear application ensure that the wiping action occurs towards the free end of the spring. Gaskets mounted onto panels are better mounted on the demountable item, and in the case of a biscuit-tin lid design, mounted inside the lid. In door sealing applications, mounting on the frame is recommended.
- The material and plating should be chosen to minimise galvanic action between the gasket and mating surfaces. Refer to the **Electrochemical Compatibility** chart (see page 3) to select the most appropriate finish.

# Installation Options

Shielding strips are designed for a wide variety of application requirements, and can be supplied cut to length or full size in any of the following mounting configurations. Consult our engineering department for special modifications to suit your requirements.

## Clip-on Mounting

Clip-on Mounting provides a reliable mechanical installation when there is an accessible mounting flange. Various flange thicknesses can be accommodated, and lances can be incorporated to enhance the holding force to the flange.

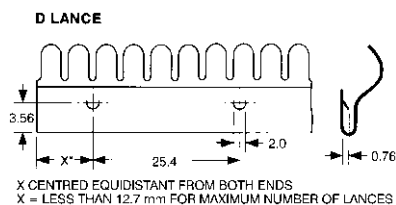

## Stick-on Mounting

Pressure Sensitive Mounting provides double-sided pressure sensitive transfer tape for a fast, reliable installation. 3M Y-9469 transfer tape is standard and may be used at ambient temperatures from -55°C to 150°C. Apply only on a clean, oil-free surface, and allow a 24-hour cure time. Consult the factory for other adhesives.

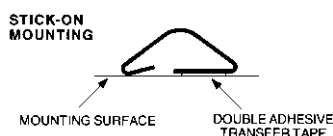

## Special Mounting

Special Mounting provides for riveting, spot welding, soldering or use of double sided tape to mount shielding strip.

## Snap-on Mounting

Snap-on shielding is ideal for bi-directional applications, such as sliding drawers, doors and rack mounted assemblies.

Snap-on shielding is easily mounted by snapping it into parallel slots or over a mounting track. The mounting track, sold separately, can be installed by screws, rivets, spot welding, or pressure-sensitive, double-adhesive transfer tape. Order "T" Retaining Caps (page 14) or Plastic Rivets for end stops for the shielding (See Figure 1 below and page 15). Stops can also be incorporated in sheet metal. Hole diameter to mount track should be 3.18mm. Specify Plastic Rivets (PR45 or PR60 on page 15), if preferred.

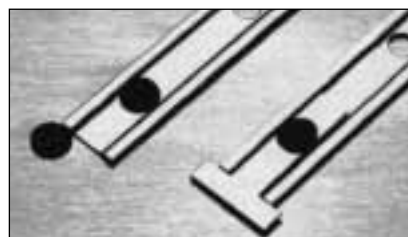
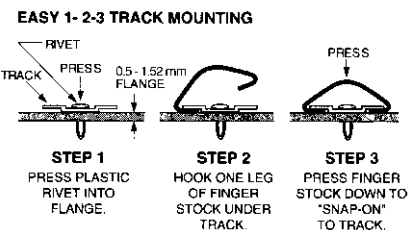
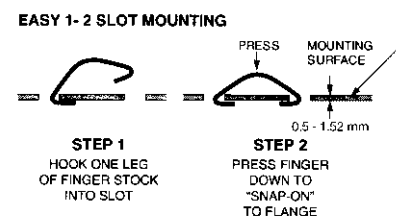
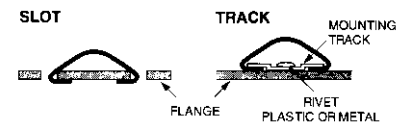

**Track Mounting Options** Track in left photo shows two shielding retainer options: Plastic Rivet Stop on the left and "T" Retainer on the right. Right photo shows track with shielding snapped into place.

## OMNI Mounting

OMNI Mounting offers snap-on shielding preassembled on brass pads. OMNI shielding comes in lengths up to 406mm and can be mounted as individual pads or in strips cut to multiples of the pad length. Double adhesive transfer tape or plastic rivets are available mounting options. The OMNI shielding configuration is also an excellent choice for bidirectional applications.

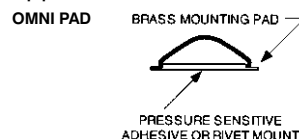

## Plastic Rivets

Plastic rivets can be used to install Track, OMNI and as rivet stops to retain shielding on a track as shown in Figure 1 and in photo below. When used on a flange, the hole diameter for the rivet should be 3.18mm. Two rivets are available: PR45 and PR60 (page 15).

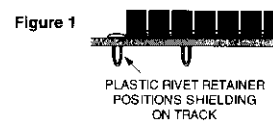

## "T" Retaining Caps

"T" Retaining Caps (page 14) can also be used to hold shielding on the Track.

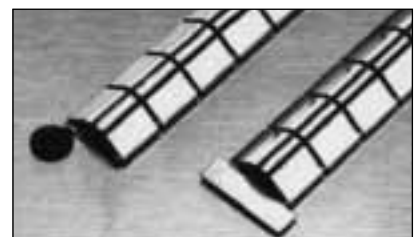
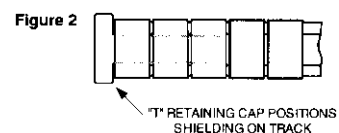

# “D” Connector Gaskets

## 9DXX

9 Pin Connector

### “D” CONNECTOR GASKET

| Part # | Material         | A    | B   |
|--------|------------------|------|-----|
| 9D10   | Stainless Steel  | 11.2 | 5.6 |
| 9D12   | Beryllium Copper | 11.2 | 5.6 |
| 9D20   | Stainless Steel  | 8.9  | 4.6 |
| 9D22   | Beryllium Copper | 8.9  | 4.6 |

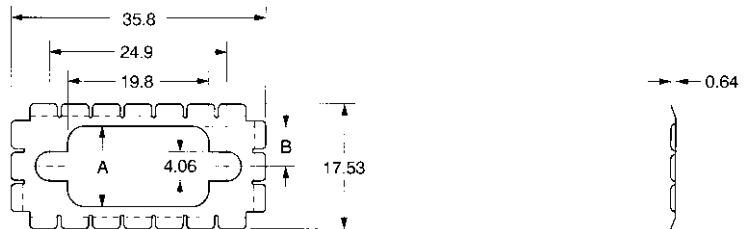

## 15DXX

15 Pin Connector

### “D” CONNECTOR GASKET

| Part # | Material         | A    | B   |
|--------|------------------|------|-----|
| 15D10  | Stainless Steel  | 11.2 | 5.6 |
| 15D12  | Beryllium Copper | 11.2 | 5.6 |
| 15D20  | Stainless Steel  | 8.9  | 4.6 |
| 15D22  | Beryllium Copper | 8.9  | 4.6 |

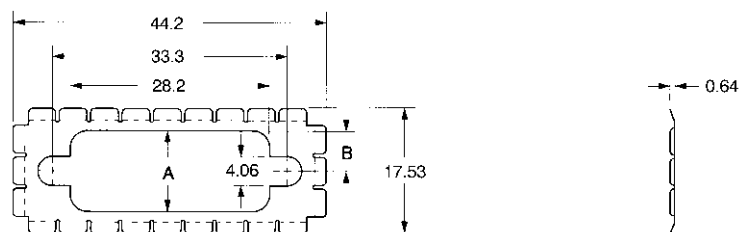

## 25DXX

25 Pin Connector

### “D” CONNECTOR GASKET

| Part # | Material         | A    | B   |
|--------|------------------|------|-----|
| 25D10  | Stainless Steel  | 11.2 | 5.6 |
| 25D12  | Beryllium Copper | 11.2 | 5.6 |
| 25D20  | Stainless Steel  | 8.9  | 4.6 |
| 25D22  | Beryllium Copper | 8.9  | 4.6 |

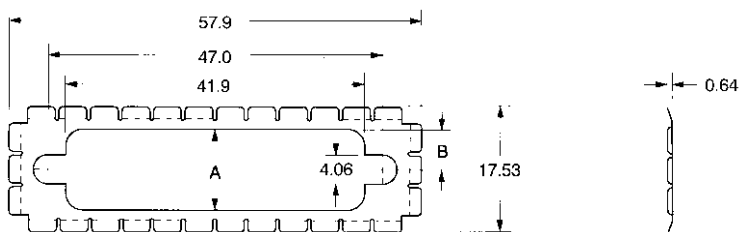

## 37DXX

37 Pin Connector

### “D” CONNECTOR GASKET

| Part # | Material         | A    | B   |
|--------|------------------|------|-----|
| 37D10  | Stainless Steel  | 11.2 | 5.6 |
| 37D12  | Beryllium Copper | 11.2 | 5.6 |
| 37D20  | Stainless Steel  | 8.9  | 4.6 |
| 37D22  | Beryllium Copper | 8.9  | 4.6 |

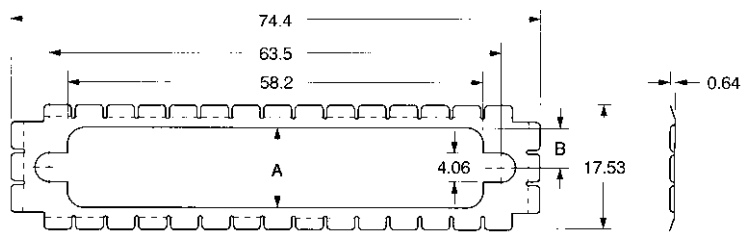

## 50DXX

50 Pin Connector

### “D” CONNECTOR GASKET

| Part # | Material         | A    | B   |
|--------|------------------|------|-----|
| 50D10  | Stainless Steel  | 14.0 | 7.1 |
| 50D12  | Beryllium Copper | 14.0 | 7.1 |
| 50D20  | Stainless Steel  | 11.4 | 5.8 |
| 50D22  | Beryllium Copper | 11.4 | 5.8 |

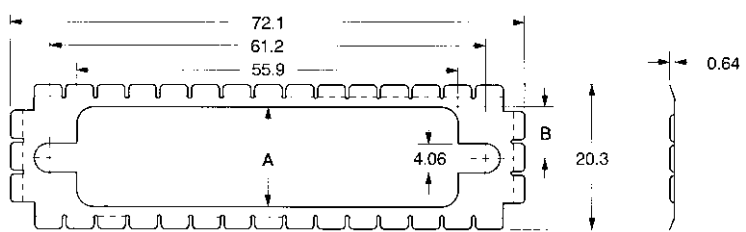

## HOW TO ORDER

To order “D” Connector Gaskets, simply supply the appropriate Item Number appended with the desired 2-digit Finish Code opposite

### FINISH

### XX

|                           |    |
|---------------------------|----|
| Clean and Bright.....     | 02 |
| Gold .....                | 03 |
| Silver .....              | 04 |
| Tin Lead .....            | 07 |
| Bright Tin .....          | 08 |
| Bright Nickel .....       | 09 |
| Zinc/Clear Chromate ..... | 15 |
| Electroless Nickel .....  | 18 |
| Other .....               | 00 |

# Pressure Sensitive Mounting

## ECP 0622

### SOFT FINGERS

#### Performance Range

|                    | 25% Compression-50% Compression |            |
|--------------------|---------------------------------|------------|
| Standard 0.05 Thk. | 22 kg/m                         | to 48 kg/m |

Material: beryllium copper – .05 mm thick

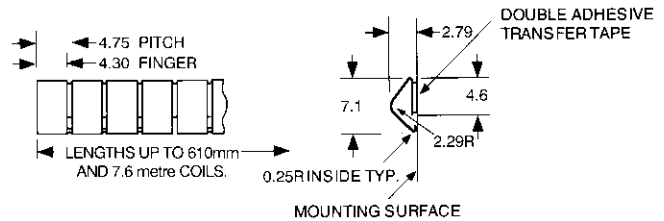

## ECP 0644

### SOFT FINGERS

#### Performance Range

|                    | 25% Compression-50% Compression |            |
|--------------------|---------------------------------|------------|
| Standard 0.05 Thk. | 21 kg/m                         | to 39 kg/m |

Material: beryllium copper – .05 mm thick

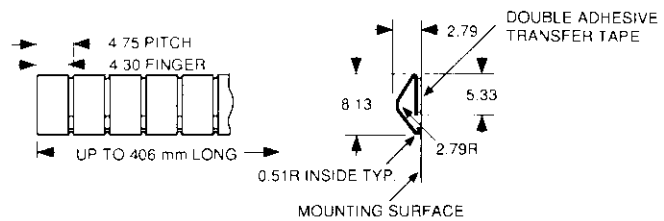

## ECP 0645

### SOFT FINGERS

#### Performance Range

|                    | 25% Compression-50% Compression |            |
|--------------------|---------------------------------|------------|
| Standard 0.05 Thk. | 15 kg/m                         | to 31 kg/m |

Material: beryllium copper – .05 mm thick

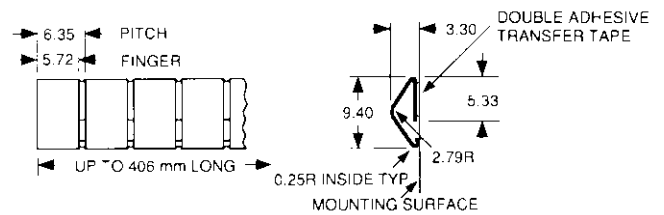

## ECP 0626

### SOFT FINGERS

#### Performance Range

|                    | 25% Compression-50% Compression |            |
|--------------------|---------------------------------|------------|
| Standard 0.05 Thk. | 15 kg/m                         | to 31 kg/m |

Material: beryllium copper – .05 mm thick

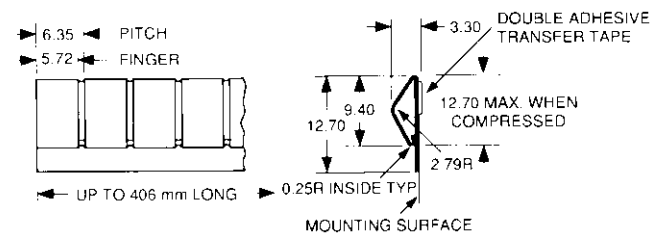

## ECP 0646

### SOFT FINGERS

#### Performance Range

|                      | 25% Compression-50% Compression |            |
|----------------------|---------------------------------|------------|
| Standard 0.089 Thk.  | 15 kg/m                         | to 30 kg/m |
| "LC" Style 0.05 Thk. | 3 kg/m                          | to 11 kg/m |

Material: beryllium copper – .09 mm thick (LC style– .05 mm thick)

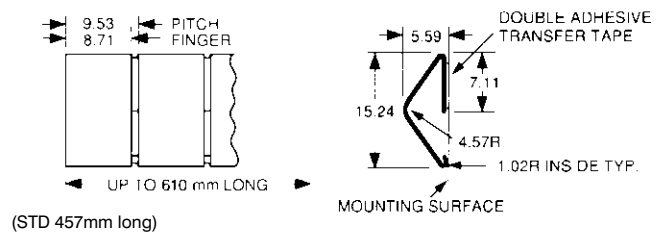

## ECP 0648

### SOFT FINGERS

#### Performance Range

|                    | 25% Compression-50% Compression |            |
|--------------------|---------------------------------|------------|
| Standard 0.10 Thk. | 10 kg/m                         | to 25 kg/m |

Material: beryllium copper – .10 mm thick

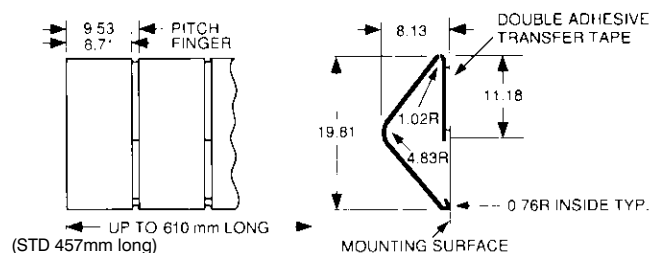



# Pressure Sensitive Mounting

**TBA**  
Protective Solutions  
EMI SHIELDING



## ECP 0647

### SOFT FINGERS

#### Performance Range

|                    | 25% Compression-50% Compression |            |
|--------------------|---------------------------------|------------|
| Standard 0.13 Thk. | 18 kg/m                         | to 36 kg/m |

Material: beryllium copper – .13 mm thick

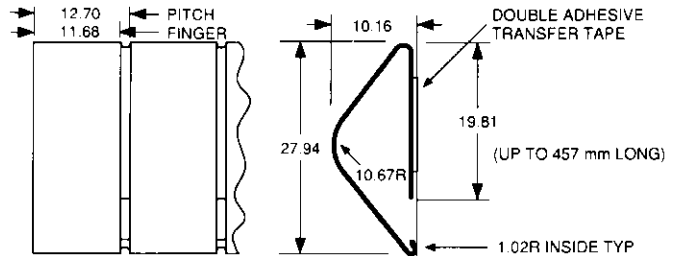

## ECP 0649

### SOFT FINGERS

#### Performance Range

|                      | 25% Compression-50% Compression |             |
|----------------------|---------------------------------|-------------|
| Standard 0.08 Thk.   | 37 kg/m                         | to 132 kg/m |
| "LC" Style 0.05 Thk. | 9 kg/m                          | to 34 kg/m  |

Material: beryllium copper – .08 mm thick (LC style– .05 mm thick)

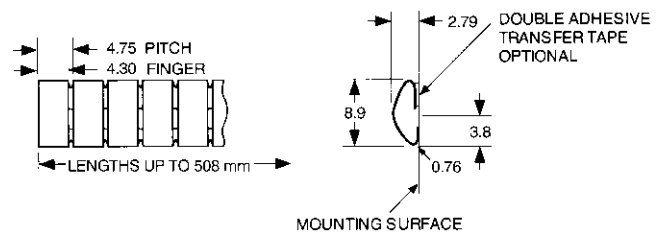

## ECP 621

### SOFT NO-SNAG FINGERS

#### Performance Range

|                    | 25% Compression-50% Compression |      |
|--------------------|---------------------------------|------|
| Standard 0.05 Thk. | *                               | to * |

Note: Consult factory for performance data.

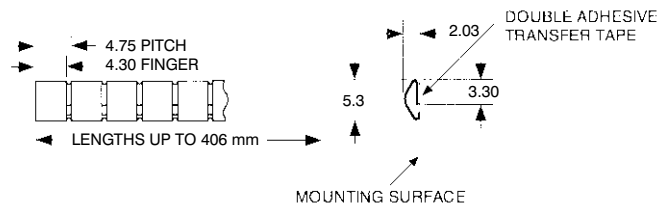

## ECP 0650

(ECP 0651 with 4.75mm pitch)

### NO-SNAG FINGERS

#### Performance Range

|                     | 25% Compression-50% Compression |             |
|---------------------|---------------------------------|-------------|
| Standard 0.089 Thk. | 45 kg/m                         | to 113 kg/m |

Material: beryllium copper – .09 mm thick

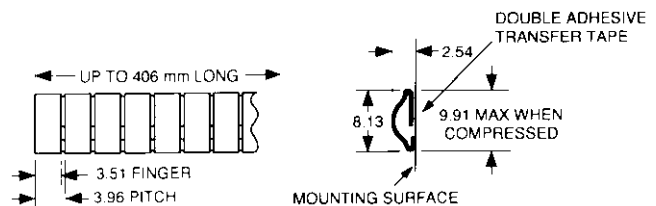

## ECP 0654

(ECP 0653 with 3.2mm pitch)

### NO-SNAG FINGERS

#### Performance Range

|                     | 25% Compression-50% Compression |            |
|---------------------|---------------------------------|------------|
| Standard 0.089 Thk. | 45 kg/m                         | to 89 kg/m |

Material: beryllium copper – .09 mm thick

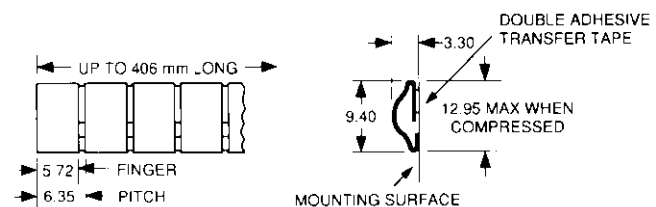

## ECP 0657

(ECP 0656 with 4.75mm pitch)

### NO-SNAG FINGERS

#### Performance Range

|                     | 25% Compression-50% Compression |            |
|---------------------|---------------------------------|------------|
| Standard 0.089 Thk. | 19 kg/m                         | to 48 kg/m |

Material: beryllium copper – .09 mm thick

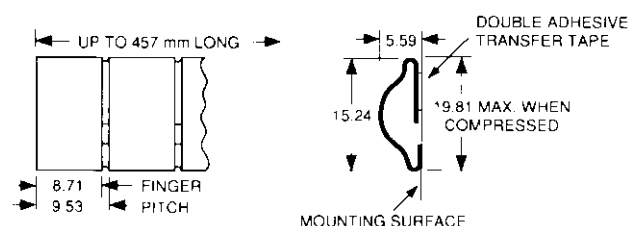

Sales 01706 647718

# Pressure Sensitive Mounting

## ECP 0658

### NO-SNAG FINGERS

#### Performance Range

|                     | 25% Compression-50% Compression |            |
|---------------------|---------------------------------|------------|
| Standard 0.089 Thk. | 19 kg/m                         | to 48 kg/m |

Material: beryllium copper – .09 mm thick

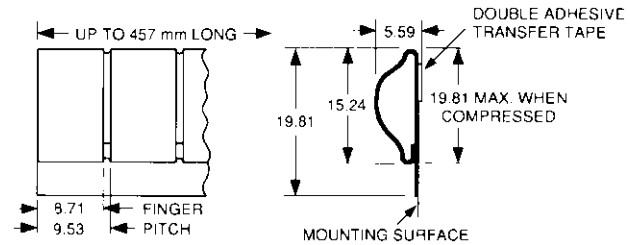

## ECP 0699

### PANEL GASKETS

#### Performance Range

|                    | 25% Compression-50% Compression |             |
|--------------------|---------------------------------|-------------|
| Standard 0.13 Thk. | 22 kg/m                         | to 103 kg/m |

Material: beryllium copper – .13 mm thick

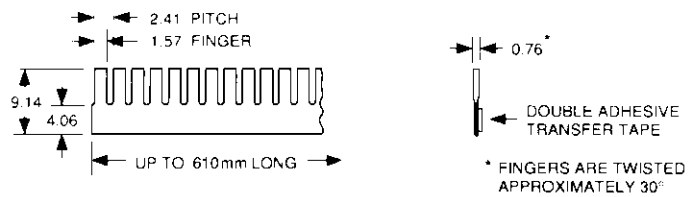

## ECP 0625

### PANEL GASKETS

#### Performance Range

|                      | 25% Compression-50% Compression |            |
|----------------------|---------------------------------|------------|
| Standard 0.08 Thk.   | 18 kg/m                         | to 71 kg/m |
| "LC" Style 0.05 Thk. | 4 kg/m                          | to 15 kg/m |

Material: beryllium copper – .08 mm thick (LC style– .05 mm thick)



## ECP 0625/90°

### PANEL GASKETS

#### Performance Range

|                    | 25% Compression-50% Compression |            |
|--------------------|---------------------------------|------------|
| Standard 0.08 Thk. | 18 kg/m                         | to 76 kg/m |

Material: beryllium copper – .08 mm thick

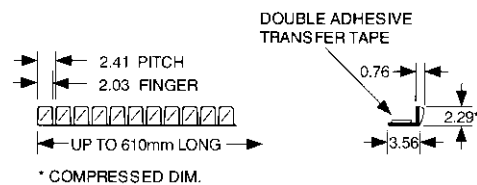

## ECP 0697

### PANEL GASKETS

#### Performance Range

|                      | 25% Compression-50% Compression |            |
|----------------------|---------------------------------|------------|
| Standard 0.08 Thk.   | 13 kg/m                         | to 33 kg/m |
| "LC" Style 0.05 Thk. | 3 kg/m                          | to 10 kg/m |

Material: beryllium copper – .08 mm thick (LC style– .05 mm thick)

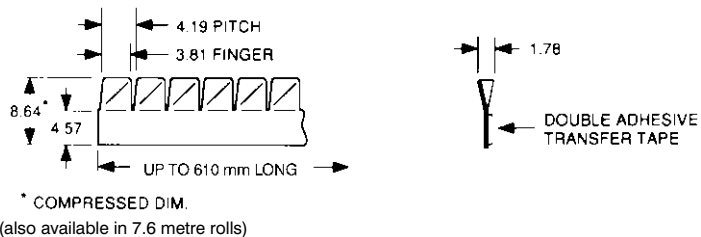

## ECP 0697/90°

### PANEL GASKETS

#### Performance Range

|                    | 25% Compression-50% Compression |            |
|--------------------|---------------------------------|------------|
| Standard 0.08 Thk. | 13 kg/m                         | to 33 kg/m |

Material: beryllium copper – .08 mm thick

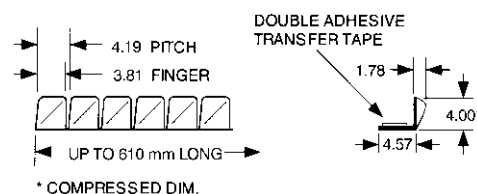

# Pressure Sensitive Mounting

## ECP 0698

### PANEL GASKETS

#### Performance Range

|                    | 25% Compression-50% Compression |            |
|--------------------|---------------------------------|------------|
| Standard 0.08 Thk. | 28 kg/m                         | to 57 kg/m |

Material: beryllium copper – .08 mm thick

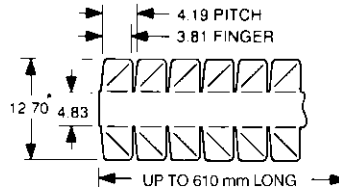

\* COMPRESSED DIM  
(also available in 7.6 metre rolls)

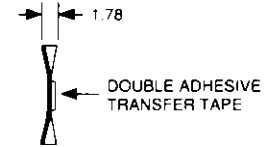

## ECP 0627

### PANEL GASKETS

#### Performance Range

|                    | 25% Compression-50% Compression |            |
|--------------------|---------------------------------|------------|
| Standard 0.08 Thk. | 7 kg/m                          | to 16 kg/m |

Material: beryllium copper – .08 mm thick

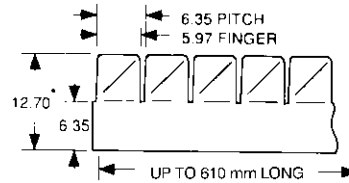

\* COMPRESSED DIM.  
(also available in 7.6 metre rolls)

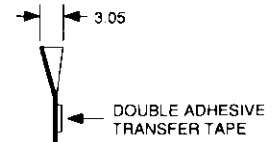

## ECP 0623

### PANEL GASKETS

#### Performance Range

|                    | 25% Compression-50% Compression |            |
|--------------------|---------------------------------|------------|
| Standard 0.10 Thk. | 21 kg/m                         | to 31 kg/m |

Material: beryllium copper – .10 mm thick

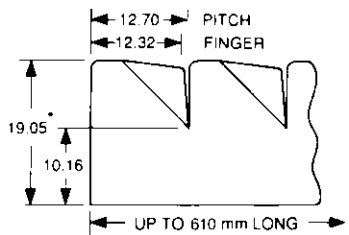

\* COMPRESSED DIM.

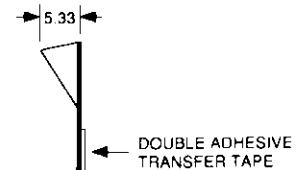

# Low Profile Gaskets

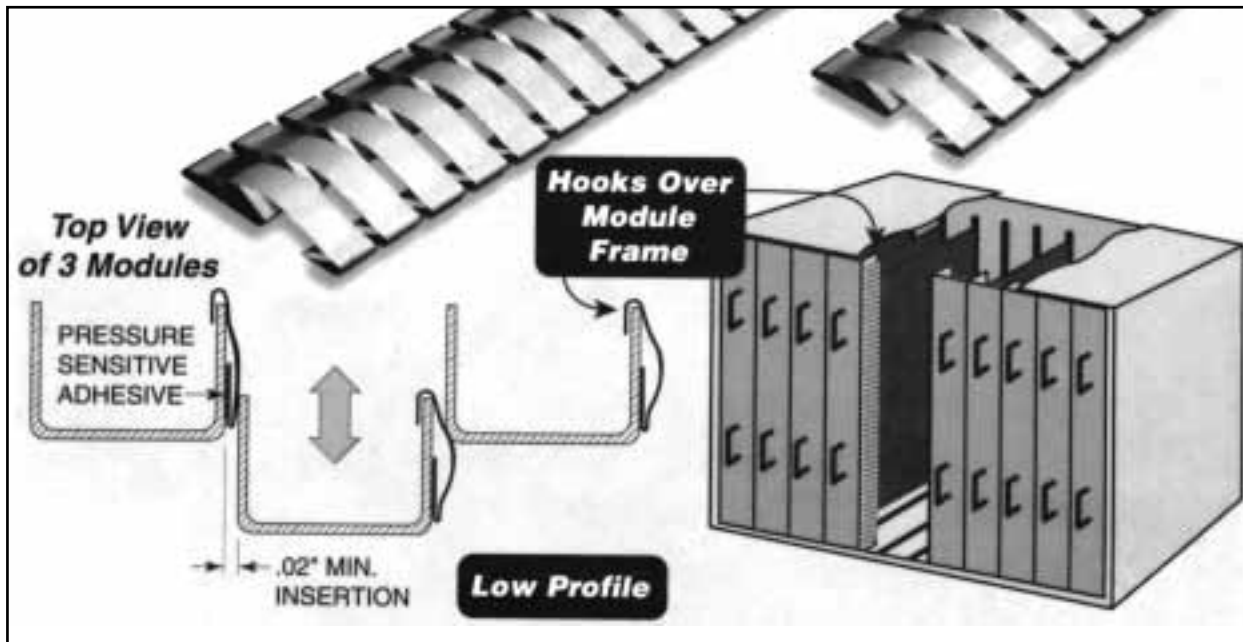

Hook-on gasket example

### Ideal shielding for Telecommunications and Other Rack Modules

- Leading edge hooks over flange for full protection.
- Self-locating, secure installation.
- Low closing force, low profile.
- Bi-directional.
- Adhesive mounting.
- Beryllium copper.

- 100db attenuation.
- 360° no-snag.
- Durable.

### Installation Guide

The leading edge of the gasket hooks over the mounting flange for full protection. The opposing side is then attached with double-sided pressure sensitive transfer tape for a fast, reliable installation.

## ECP 630

### NO-SNAG FINGERS

#### Performance Range

|                  | 25% Compression-50% Compression |            |
|------------------|---------------------------------|------------|
| Standard 0.05 mm | 8 kg/m                          | to 30 kg/m |

\* Note: Consult factory for performance data.

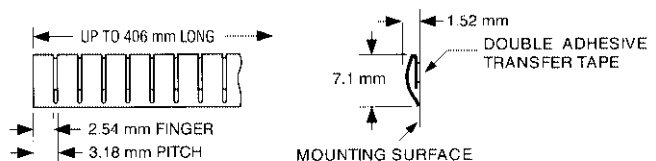

# Low Profile Gaskets

“Eliminates Shearing”

## ECP 632

### NO-SNAG FINGERS

#### Performance Range

|                       | 25% Compression-50% Compression |    |         |
|-----------------------|---------------------------------|----|---------|
| Standard 0.089 Thk.   | 15 kg/m                         | to | 28 kg/m |
| "LC" Style 0.069 Thk. | 9 kg/m                          | to | 24 kg/m |

\* Note: Consult factory for performance data.

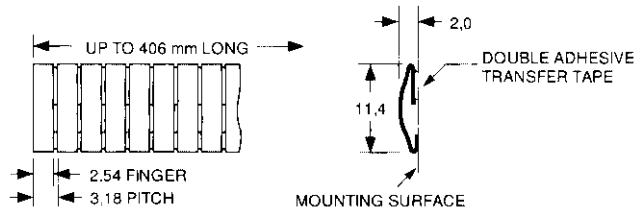

## ECP 636

### NO-SNAG FINGERS

#### Performance Range

|                       | 25% Compression-50% Compression |    |         |
|-----------------------|---------------------------------|----|---------|
| Standard 0.089 Thk.   | 12 kg/m                         | to | 23 kg/m |
| "LC" Style 0.069 Thk. | 8 kg/m                          | to | 13 kg/m |

\* Note: Consult factory for performance data.

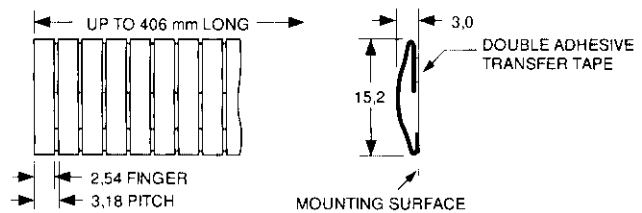

## ECP 632HO

### NO-SNAG FINGERS HOOK ON

#### Performance Range

|                      | 25% Compression-50% Compression |    |         |
|----------------------|---------------------------------|----|---------|
| Standard 0.09 Thk.   | 17 kg/m                         | to | 37 kg/m |
| "LC" Style 0.07 Thk. | 9 kg/m                          | to | 24 kg/m |

\* Note: Consult factory for performance data.

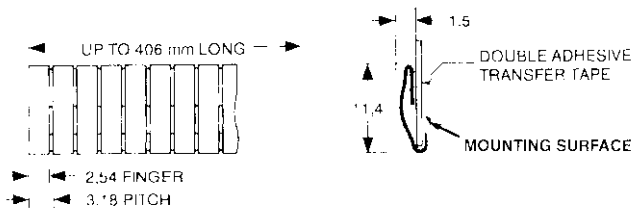

## ECP 636HO

### NO-SNAG FINGERS HOOK ON

#### Performance Range

|                      | 25% Compression-50% Compression |    |         |
|----------------------|---------------------------------|----|---------|
| Standard 0.09 Thk.   | 12 kg/m                         | to | 23 kg/m |
| "LC" Style 0.07 Thk. | 8 kg/m                          | to | 13 kg/m |

\* Note: Consult factory for performance data.

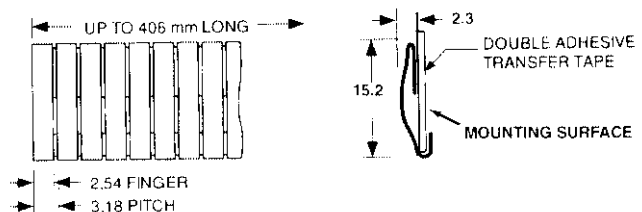

## ECP 634

### LOW PROFILE CLIP ON

#### Performance Range

|                      | 25% Compression-50% Compression |    |   |
|----------------------|---------------------------------|----|---|
| Standard 0.09 Thk.   | *                               | to | * |
| "LC" Style 0.07 Thk. | *                               | to | * |

\* Note: Consult factory for performance data.

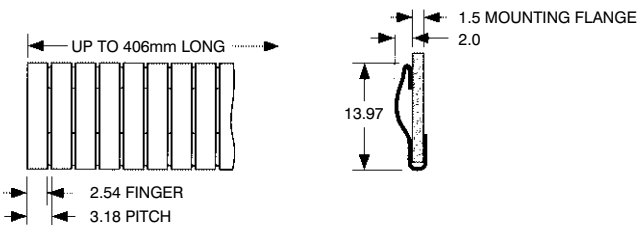

## ECP 638

### LOW PROFILE CLIP ON

#### Performance Range

|                      | 25% Compression-50% Compression |    |   |
|----------------------|---------------------------------|----|---|
| Standard 0.09 Thk.   | *                               | to | * |
| "LC" Style 0.07 Thk. | *                               | to | * |

\* Note: Consult factory for performance data.

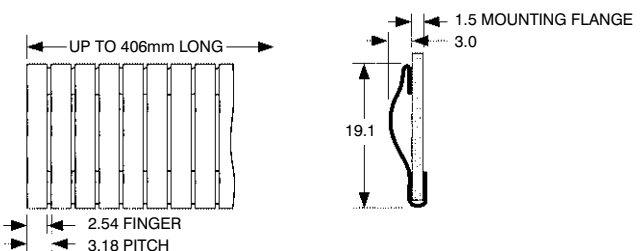

# Snap-on Mounting

## “SNAP-ON” RFI/EMI SHIELDING

### SNAP-ON RFI/EMI SHIELDING SERIES

Snap-on shielding is easily mounted by snapping it either into parallel slots or over a mounting track. The mounting track can be installed by screws, rivets or spot welding. Where needed, “T” Retaining Caps hold the shielding strips on the track. Snap-on shielding features a no-slag design and provides secure mechanical fastening to insure long life for frequently used cabinet doors and panels.

Available in a wide range of plating options, the Snap-on Series is ideal for any bi-directional application, such as sliding drawers, doors and rack mounted assemblies. It comes in lengths up to 406mm and various widths.

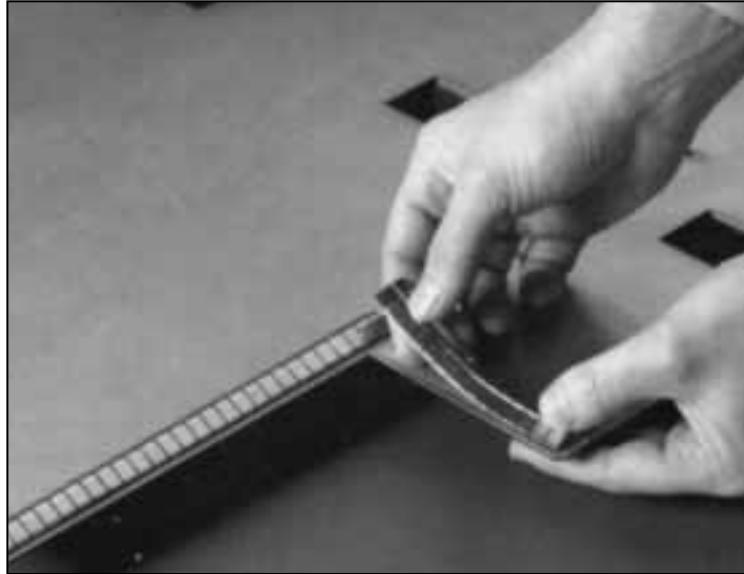

*The Snap-on Series provides the security of mechanical fastening and the performance of top-quality Beryllium Copper shield at a reasonable price.*

### SLOT MOUNTING

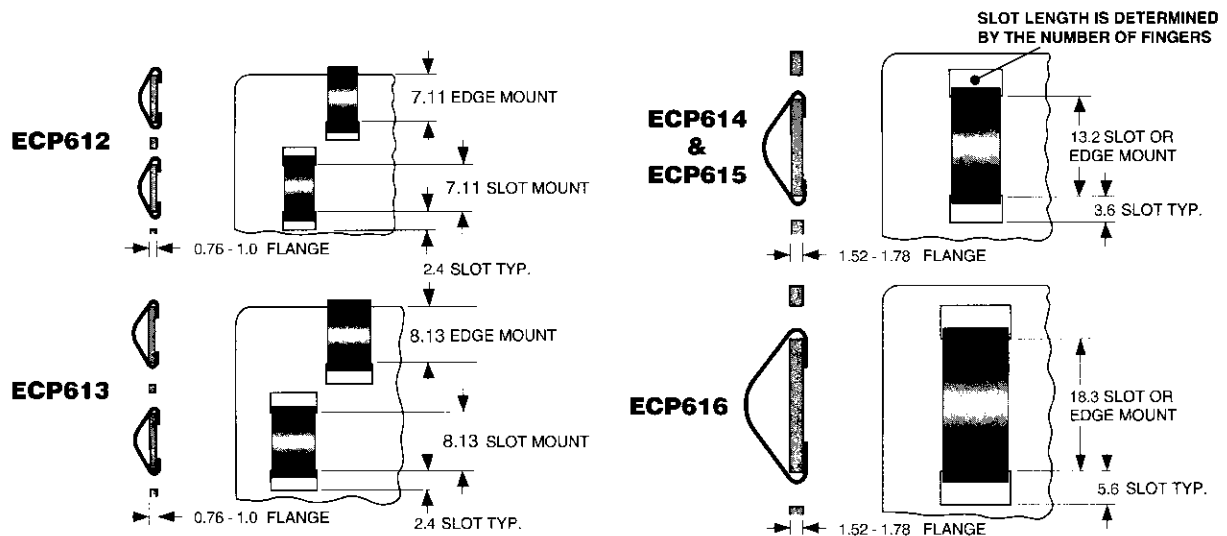

# Snap-on Mounting

## ECP 610

### SYMMETRICAL

#### Performance Range

|                  | 25% Compression-50% Compression |            |
|------------------|---------------------------------|------------|
| Standard 0.05 mm | 14 kg/m                         | to 27 kg/m |

\* Note: Consult factory for performance data.

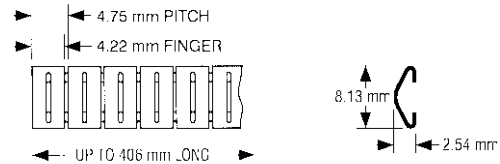

## ECP 0612

### SYMMETRICAL

#### Performance Range

|                      | 25% Compression-50% Compression |             |
|----------------------|---------------------------------|-------------|
| Standard 0.089 Thk.  | 43 kg/m                         | to 109 kg/m |
| "LC" Style 0.05 Thk. | 13 kg/m                         | to 42 kg/m  |

Material: beryllium copper - .09 mm thick (LC style- .05 mm thick)

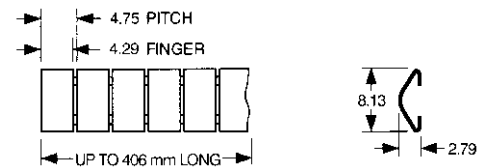

## ECP 0613

### SYMMETRICAL

#### Performance Range

|                    | 25% Compression-50% Compression |            |
|--------------------|---------------------------------|------------|
| Standard 0.05 Thk. | 13 kg/m                         | to 25 kg/m |

Material: beryllium copper - .05 mm thick

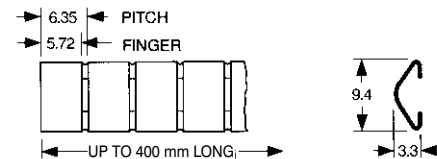

## ECP 0614

### SYMMETRICAL

#### Performance Range

|                      | 25% Compression-50% Compression |             |
|----------------------|---------------------------------|-------------|
| Standard 0.13 Thk.   | 65 kg/m                         | to 149 kg/m |
| "LC" Style 0.08 Thk. | 6 kg/m                          | to 10 kg/m  |

Material: beryllium copper - .13 mm thick (LC style- .08 mm thick)

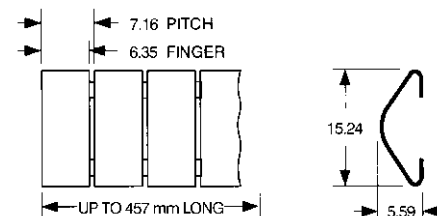

## ECP 0615

### SYMMETRICAL

#### Performance Range

|                      | 25% Compression-50% Compression |            |
|----------------------|---------------------------------|------------|
| Standard 0.089 Thk.  | 18 kg/m                         | to 40 kg/m |
| "LC" Style 0.05 Thk. | 4 kg/m                          | to 12 kg/m |

Material: beryllium copper - .09 mm thick (LC style- .05 mm thick)

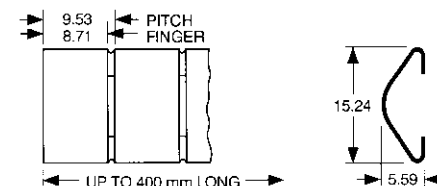

## ECP 0616

### SYMMETRICAL

#### Performance Range

|                      | 25% Compression-50% Compression |            |
|----------------------|---------------------------------|------------|
| Standard 0.10 Thk.   | 25 kg/m                         | to 51 kg/m |
| "LC" Style 0.08 Thk. | 6 kg/m                          | to 9 kg/m  |

Material: beryllium copper - .10 mm thick (LC style- .08 mm thick)

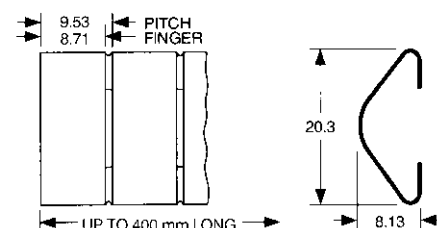

# Track Mounting

## TR32

### (FOR ECP 612)

Track sold separately.  
Burr side of mounting hole should be opposite rivet entry side.  
Material: Stainless Steel.  
Finish: Bright.

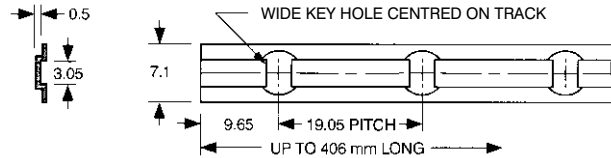

## TR37A or B or C

### (FOR ECP 613)

Track sold separately.  
Burr side of mounting hole should be opposite rivet entry side.  
Material: Brass.  
Finish: Bright.

|         | HOLE             |
|---------|------------------|
| A       | 3.18 dia         |
| B (STD) | 3.45 dia.        |
| C       | 3.56 x 5.08 slot |

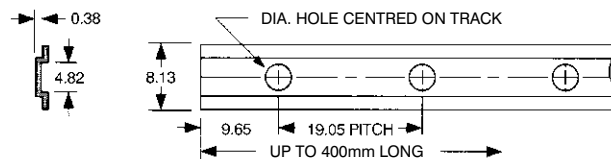

## TR60A or B or C

### (FOR ECP 615)

Track sold separately.  
Burr side of mounting hole should be opposite rivet entry side.  
Material: Brass.  
Finish: Bright.

|         | HOLE             |
|---------|------------------|
| A       | 3.18 dia         |
| B (STD) | 3.45 dia.        |
| C       | 3.56 x 5.08 slot |

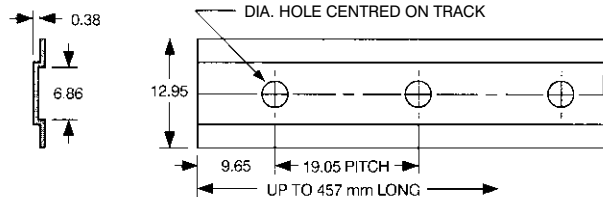

## TR80A or B or C

### (FOR ECP 0616)

Track sold separately.  
Burr side of mounting hole should be opposite rivet entry side.  
Material: Brass.  
Finish: Bright.

|         | HOLE             |
|---------|------------------|
| A       | 3.18 dia         |
| B (STD) | 3.45 dia.        |
| C       | 3.56 x 5.08 slot |

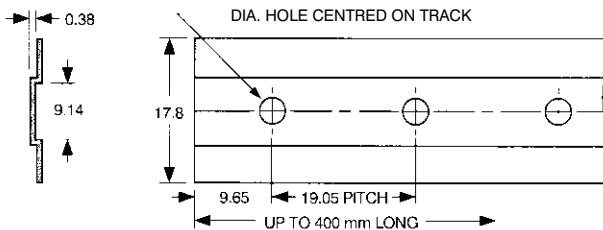



# Track Mounting

## PR45

### PLASTIC RIVET

Used on Snap-on Track and OMNI Mounting Pads.  
Panel Hole Dia. 3.1 – 3.22 mm  
Panel Thickness 0.5 – 1.52 mm  
Order PR45 Rivets, if required for your application.

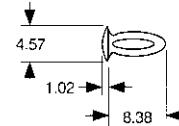

## PR60

### PLASTIC RIVET

Used on Snap-on Track and OMNI Mounting Pads.  
Panel Hole Dia. 3.0 – 3.18 mm  
Panel Thickness 1.14 – 1.9 mm  
Order PR60 Rivets, if required for your application.

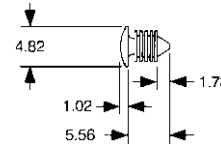

## TCXX

### “T” RETAINING CAPS

“T” Retaining Caps are used at the ends of Mounting Track to hold finger stock in place. Material: Brass. Finish: Bright.

| “T” CAP | “A”  | “B”  |
|---------|------|------|
| TC32    | 11.4 | 4.06 |
| TC37    | 11.4 | 4.06 |
| TC60    | 17.8 | 6.6  |
| TC80    | 25.4 | 8.9  |

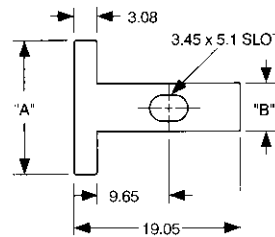

# Omni Mounting

## ECP 613 OMNI

### Performance Range – Single Contact

|                    | 25% Compression-50% Compression |            |
|--------------------|---------------------------------|------------|
| Standard 0.05 Thk. | 0.09 kg                         | to 0.18 kg |

Mounting Pad Material: Brass. Finish: Bright.

Other finishes are also available.

Material: beryllium copper – .05 mm thick

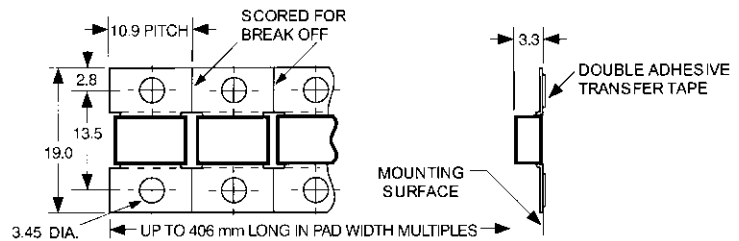

## ECP 614 OMNI

### Performance Range – Single Contact

|                    | 25% Compression-50% Compression |            |
|--------------------|---------------------------------|------------|
| Standard 0.08 Thk. | 0.02 kg                         | to 0.09 kg |

Mounting Pad Material: Brass. Finish: Bright.

Other finishes are also available.

Material: beryllium copper – .08 mm thick

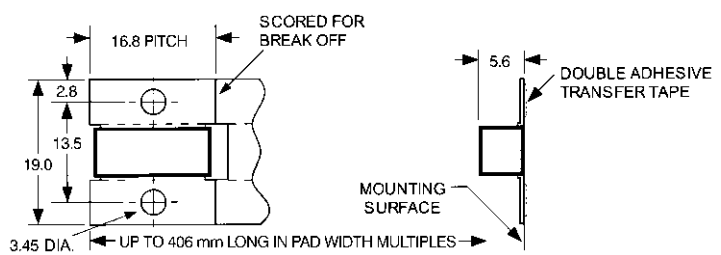

## ECP 616 OMNI

### Performance Range – Single Contact

|                    | 25% Compression-50% Compression |           |
|--------------------|---------------------------------|-----------|
| Standard 0.10 Thk. | 0.2 kg                          | to 0.9 kg |

Mounting Pad Material: Brass. Finish: Bright.

Other finishes are also available.

Material: beryllium copper – .10 mm thick

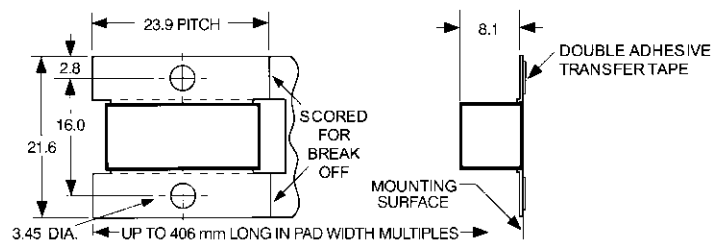

# Clip-on Mounting

## ECP 0642

### CYLINDRICAL RADIUS

#### Performance Range

|                       | 25% Compression-50% Compression |             |
|-----------------------|---------------------------------|-------------|
| Standard 0.13 Thk.    | 16 kg/m                         | to 103 kg/m |
| "LC" Style 0.089 Thk. | 10 kg/m                         | to 31 kg/m  |

Material: beryllium copper – .13 mm thick (LC style – .09 mm thick)

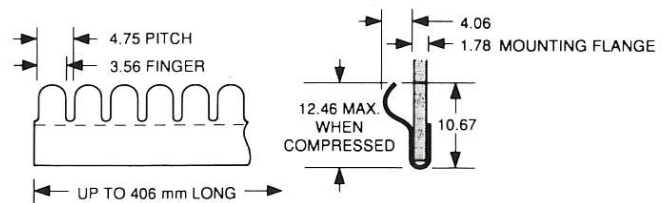

## ECP 0678A or B

### CYLINDRICAL RADIUS

#### Performance Range

|                    | 25% Compression-50% Compression |            |
|--------------------|---------------------------------|------------|
| Standard 0.13 Thk. | 5 kg/m                          | to 24 kg/m |

Material: beryllium copper – .13 mm thick

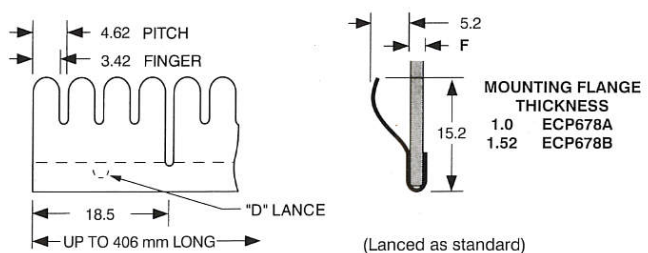

# Clip-on Mounting

## ECP 0682A or B

### STRIP GASKETS

#### Performance Range

|                    | 25% Compression | 50% Compression |
|--------------------|-----------------|-----------------|
| Standard 0.13 Thk. | 25 kg/m         | to 64 kg/m      |

Note: Drawing shown at reduced scale.  
Material: beryllium copper - .13 mm thick

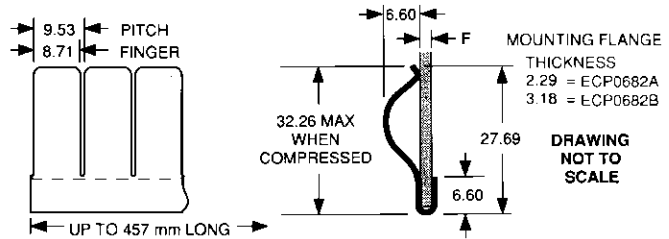

## ECP 0640A

### REVERSE BEND CONTACTS

#### Performance Range

|                    | 25% Compression | 50% Compression |
|--------------------|-----------------|-----------------|
| Standard 0.13 Thk. | 7 kg/m          | to 22 kg/m      |

Note: Also available in 7.6 metre rolls.  
Scores for break off between 12.7 mm increments optional.  
Material: beryllium copper - .13 mm thick

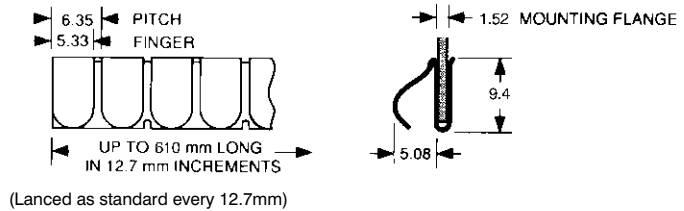

## ECP 0640B

### REVERSE BEND CONTACTS

#### Performance Range

|                    | 25% Compression | 50% Compression |
|--------------------|-----------------|-----------------|
| Standard 0.13 Thk. | 12 kg/m         | to 28 kg/m      |

Note: Also available in 7.6 metre rolls.  
Scores for break off between 12.7 mm increments optional.  
Material: beryllium copper - .13 mm thick

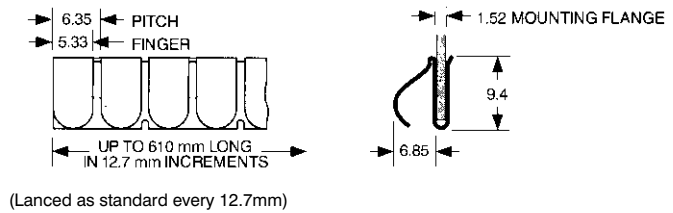

## ECP 0692

### REVERSE BEND CONTACTS

#### Performance Range

|                    | 25% Compression | 50% Compression |
|--------------------|-----------------|-----------------|
| Standard 0.13 Thk. | 18 kg/m         | to 65 kg/m      |

Material: beryllium copper - .13 mm thick

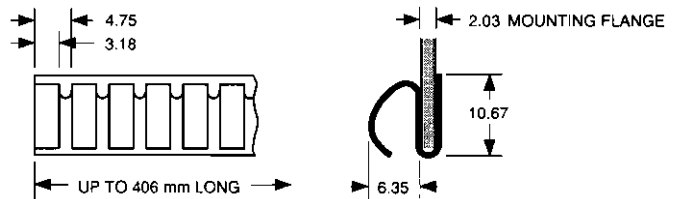

## ECP 641

### PERPENDICULAR CONTACTS

#### Performance Range

|                      | 25% Compression | 50% Compression |
|----------------------|-----------------|-----------------|
| Standard 0.13 Thk.   | *               | to *            |
| "LC" Style 0.08 Thk. | *               | to *            |

\*Note: Consult factory for performance data.

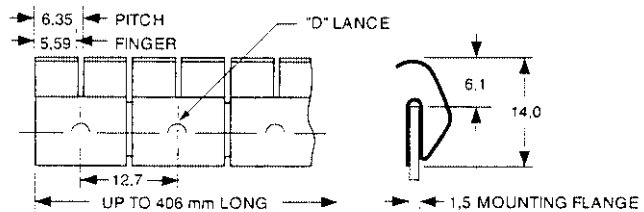

# Clip-on Mounting

## ECP 0671A or B

### CYLINDRICAL RADIUS

#### Performance Range

|                       | 25% Compression-50% Compression |             |
|-----------------------|---------------------------------|-------------|
| Standard 0.15 Thk.    | 22 kg/m                         | to 124 kg/m |
| "LC" Style 0.089 Thk. | 10 kg/m                         | to 45 kg/m  |

Material: beryllium copper - .15 mm thick

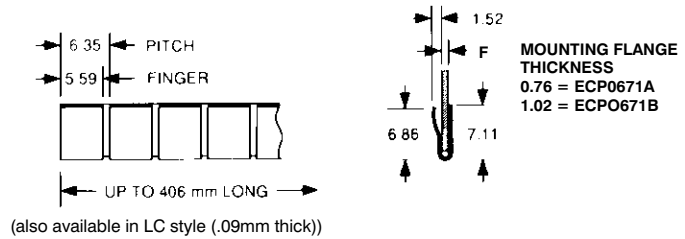

## ECP 0667A or B or C

### CYLINDRICAL RADIUS

#### Performance Range

|                    | 25% Compression-50% Compression |             |
|--------------------|---------------------------------|-------------|
| Standard 0.13 Thk. | 18 kg/m                         | to 138 kg/m |

Material: beryllium copper - .13 mm thick

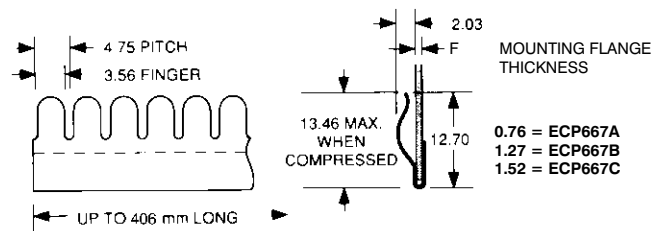

## ECP 0668A or B or C

### CYLINDRICAL RADIUS

#### Performance Range

|                    | 25% Compression-50% Compression |             |
|--------------------|---------------------------------|-------------|
| Standard 0.13 Thk. | 34 kg/m                         | to 208 kg/m |

Material: beryllium copper - .13 mm thick

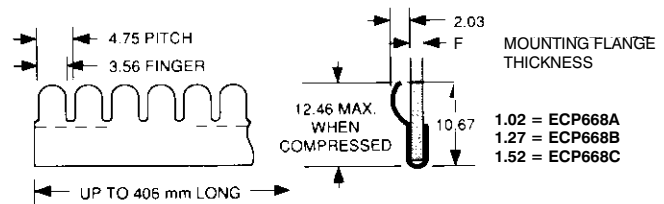

## ECP 669A or B

### CYLINDRICAL RADIUS

#### Performance Range

|                      | 25% Compression-50% Compression |            |
|----------------------|---------------------------------|------------|
| Standard 0.13 Thk.   | 21 kg/m                         | to 73 kg/m |
| "LC" Style 0.08 Thk. | 7 kg/m                          | to 33 kg/m |

Material: beryllium copper - .13 mm thick (LC style - .08 mm thick)

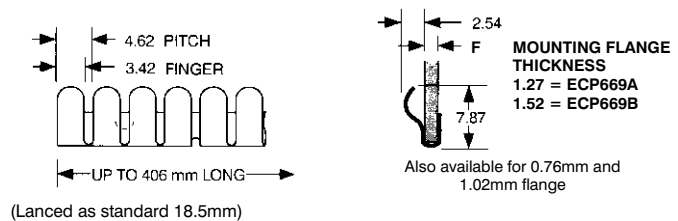

## ECP 0672A or B or C

### CYLINDRICAL RADIUS

#### Performance Range

|                    | 25% Compression-50% Compression |             |
|--------------------|---------------------------------|-------------|
| Standard 0.13 Thk. | 18 kg/m                         | to 125 kg/m |

Material: beryllium copper - .13 mm thick

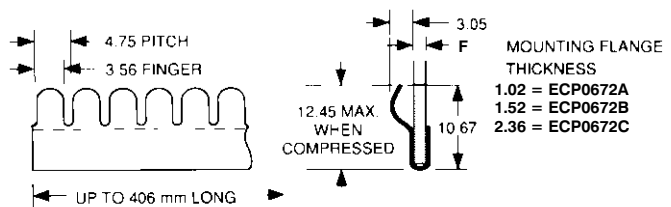

## ECP 0674

### CYLINDRICAL RADIUS

#### Performance Range

|                       | 25% Compression-50% Compression |        |
|-----------------------|---------------------------------|--------|
| Standard 0.13 Thk.    | 27 kg/m                         | to N/A |
| "LC" Style 0.089 Thk. | Consult the factory             |        |

Material: beryllium copper - .13 mm thick (LC style - .09 mm thick)

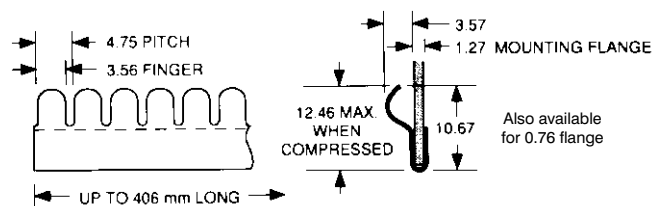

# Clip-on Mounting

## ECP 0643

### TWISTED CONTACTS

#### Performance Range

|                    | 25% Compression-50% Compression |            |
|--------------------|---------------------------------|------------|
| Standard 0.08 Thk. | 15 kg/m                         | to 33 kg/m |

Material: beryllium copper – .08 mm thick

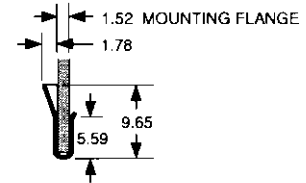
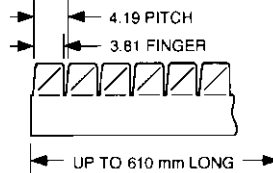

## ECP 0643M

### TWISTED CONTACTS

#### Performance Range

|                    | 25% Compression-50% Compression |            |
|--------------------|---------------------------------|------------|
| Standard 0.08 Thk. | 15 kg/m                         | to 33 kg/m |

Material: beryllium copper – .08 mm thick

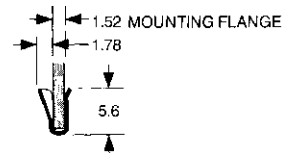
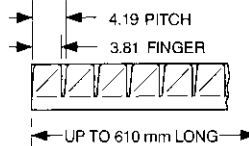

## ECP 0625CO

### TWISTED CONTACTS

#### Performance Range

|                    | 25% Compression-50% Compression |            |
|--------------------|---------------------------------|------------|
| Standard 0.08 Thk. | 48 kg/m                         | to 71 kg/m |

Material: beryllium copper – .08 mm thick

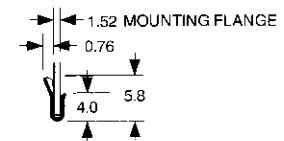
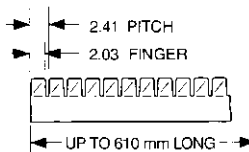

## ECP 0625COM

### TWISTED CONTACTS

#### Performance Range

|                    | 25% Compression-50% Compression |            |
|--------------------|---------------------------------|------------|
| Standard 0.08 Thk. | 48 kg/m                         | to 71 kg/m |

Material: beryllium copper – .08 mm thick

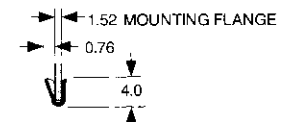
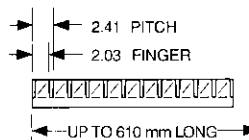

## ECP 0652A or B or C

### NO-SNAG FINGERS

#### Performance Range

|                       | 25% Compression-50% Compression |             |
|-----------------------|---------------------------------|-------------|
| Standard 0.089 Thk.   | 43 kg/m                         | to 103 kg/m |
| "LC" Style 0.064 Thk. | 22 kg/m                         | to 51 kg/m  |

Material: beryllium copper – .09 mm thick (LC style– .06 mm thick)

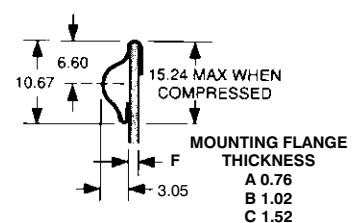
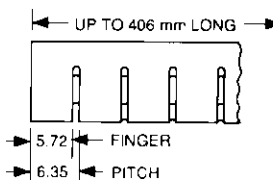

## ECP 0629

### SOFT FINGERS

#### Performance Range

|                     | 25% Compression-50% Compression |            |
|---------------------|---------------------------------|------------|
| Standard 0.089 Thk. | 27 kg/m                         | to 54 kg/m |

Material: beryllium copper – .09 mm thick

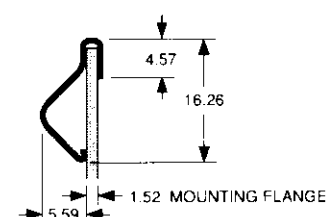
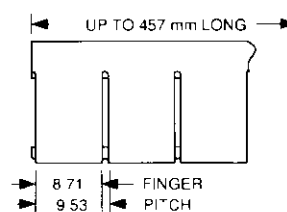

# Special Mounting

## ECP 0693

### REVERSE BEND SPHERICAL

#### Performance Range

|                    | 25% Compression-50% Compression |            |
|--------------------|---------------------------------|------------|
| Standard 0.13 Thk. | 10 kg/m                         | to 15 kg/m |

Material: beryllium copper – .10 mm thick

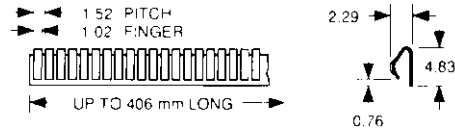

## ECP 0694

### REVERSE BEND SPHERICAL

#### Performance Range

|                    | 25% Compression-50% Compression |            |
|--------------------|---------------------------------|------------|
| Standard 0.15 Thk. | 13 kg/m                         | to 25 kg/m |

Material: beryllium copper – .16 mm thick

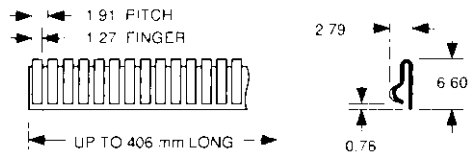

## ECP 0696

### REVERSE BEND SPHERICAL

#### Performance Range

|                    | 25% Compression-50% Compression |            |
|--------------------|---------------------------------|------------|
| Standard 0.25 Thk. | 22 kg/m                         | to 70 kg/m |

Material: beryllium copper – .25 mm thick

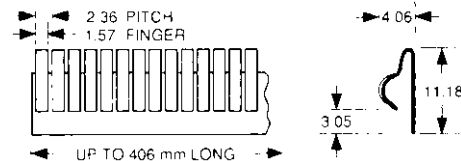

## ECP 0689

### REVERSE BEND CONTACTS

#### Performance Range

|                    | 25% Compression-50% Compression |            |
|--------------------|---------------------------------|------------|
| Standard 0.10 Thk. | 27 kg/m                         | to 61 kg/m |

Material: beryllium copper – .10 mm thick

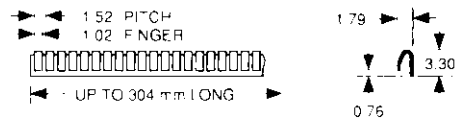

## ECP 0683

### REVERSE BEND CONTACTS

#### Performance Range

|                    | 25% Compression-50% Compression |            |
|--------------------|---------------------------------|------------|
| Standard 0.13 Thk. | 27 kg/m                         | to 73 kg/m |

Material: beryllium copper – .13 mm thick

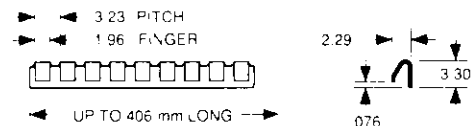

# Special Mounting

## ECP 0685

### REVERSE BEND CONTACTS

#### Performance Range

|                    | 25% Compression-50% Compression |             |
|--------------------|---------------------------------|-------------|
| Standard 0.25 Thk. | 6 kg/m                          | to 143 kg/m |

Material: beryllium copper – .25 mm thick

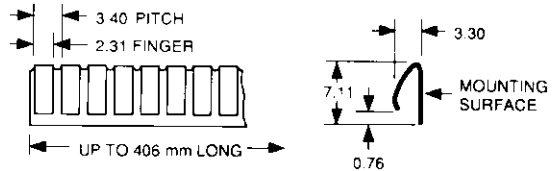

## ECP 0690

### REVERSE BEND CONTACTS

#### Performance Range

|                    | 25% Compression-50% Compression |            |
|--------------------|---------------------------------|------------|
| Standard 0.25 Thk. | 30 kg/m                         | to 91 kg/m |

Material: beryllium copper – .25 mm thick

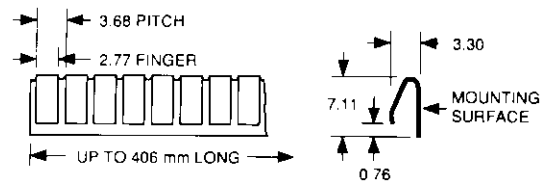

## ECP 0686

### REVERSE BEND CONTACTS

#### Performance Range

|                      | 25% Compression-50% Compression |             |
|----------------------|---------------------------------|-------------|
| Standard 0.25 Thk.   | 27 kg/m                         | to 238 kg/m |
| "LC" Style 0.14 Thk. | 10 kg/m                         | to 40 kg/m  |

Material: beryllium copper – .25 mm thick (LC style– .13 mm thick)

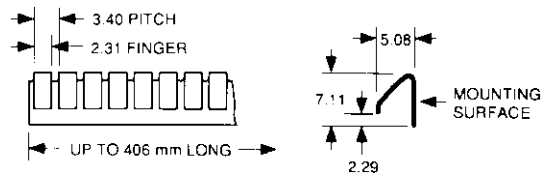

## ECP 0691

### REVERSE BEND CONTACTS

#### Performance Range

|                    | 25% Compression-50% Compression |            |
|--------------------|---------------------------------|------------|
| Standard 0.15 Thk. | 7 kg/m                          | to 22 kg/m |

Material: beryllium copper – .15 mm thick

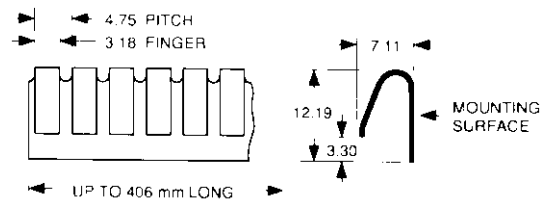

## ECP 0688

### REVERSE BEND CONTACTS

#### Performance Range

|                    | 25% Compression-50% Compression |            |
|--------------------|---------------------------------|------------|
| Standard 0.25 Thk. | 24 kg/m                         | to 68 kg/m |

Material: beryllium copper – .25 mm thick

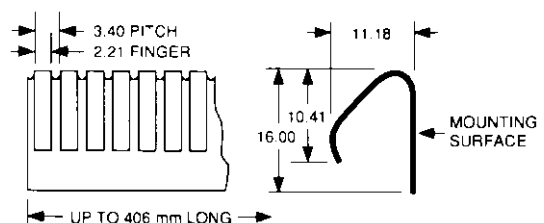

# Special Mounting

## ECP 0681

### CYLINDRICAL RADIUS

#### Performance Range

|                    | 25% Compression-50% Compression |
|--------------------|---------------------------------|
| Standard 0.10 Thk. | 27 kg/m to 71 kg/m              |

Material: beryllium copper - .10 mm thick

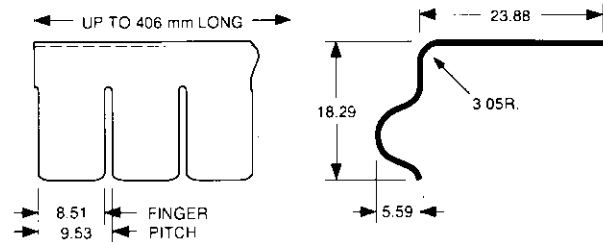

## ECP 0680

### STRIP GASKETS

#### Performance Range

|                    | 25% Compression-50% Compression |
|--------------------|---------------------------------|
| Standard 0.13 Thk. | 22 kg/m to 61 kg/m              |

Note: Drawing shown at reduced scale.

Material: beryllium copper - .13 mm thick

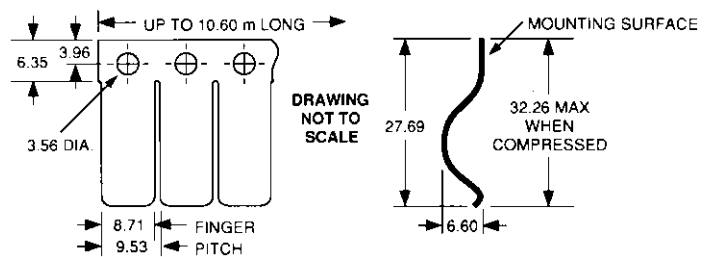

## ECP 0624

### STRIP GASKETS

#### Performance Range

|                    | 25% Compression-50% Compression |
|--------------------|---------------------------------|
| Standard 0.18 Thk. | 24 kg/m to 48 kg/m              |

Note: Drawing shown at reduced scale.

Material: beryllium copper - .18 mm thick

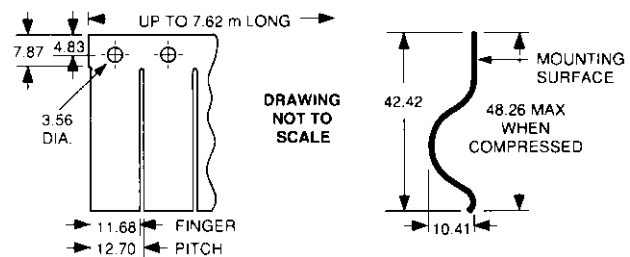

## ECP 0676

### CYLINDRICAL RADIUS

Elastic performance data available for specific customer gap requirements. Consult factory.

Material: beryllium copper - .13 mm thick

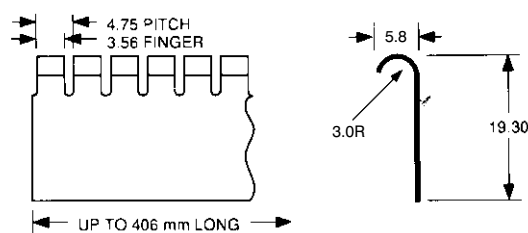

## ECP 0675

### CYLINDRICAL RADIUS

Elastic performance data available for specific customer gap requirements. Consult factory.

Material: beryllium copper - .13 mm thick

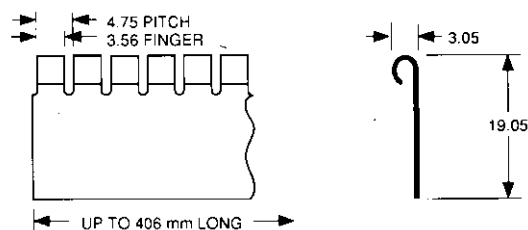

## ECP 0670A or B

### CYLINDRICAL RADIUS

#### Performance Range

|                    | 25% Compression-50% Compression |
|--------------------|---------------------------------|
| Standard 0.13 Thk. | 4 kg/m to 9 kg/m                |

Material: beryllium copper - .13 mm thick

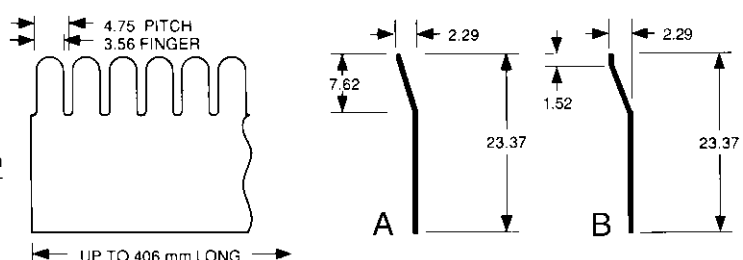



# Special Mounting

## ECP 0673

### CYLINDRICAL RADIUS

#### Performance Range

|                    | 25% Compression-50% Compression |            |
|--------------------|---------------------------------|------------|
| Standard 0.13 Thk. | 12 kg/m                         | to 55 kg/m |

Material: beryllium copper – .13 mm thick

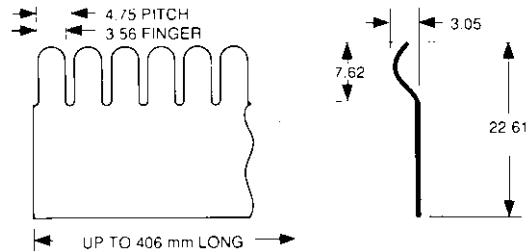

## ECP 0677

### CYLINDRICAL RADIUS

#### Performance Range

|                    | 25% Compression-50% Compression |             |
|--------------------|---------------------------------|-------------|
| Standard 0.13 Thk. | 25 kg/m                         | to 109 kg/m |

Material: beryllium copper – .08 mm thick

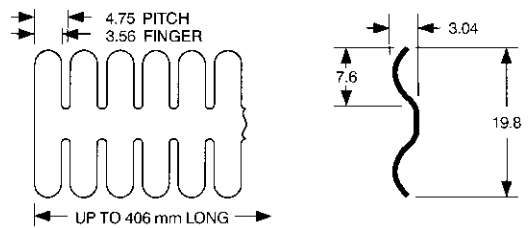

## ECP 0660

### SPHERICAL RADIUS

Elastic performance data available for specific customer gap requirements. Consult factory.

Material: beryllium copper – .10 mm thick

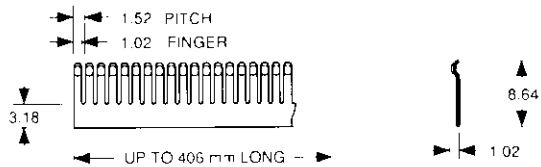

## ECP 0661

### SPHERICAL RADIUS

Elastic performance data available for specific customer gap requirements. Consult factory.

Material: beryllium copper – .16 mm thick

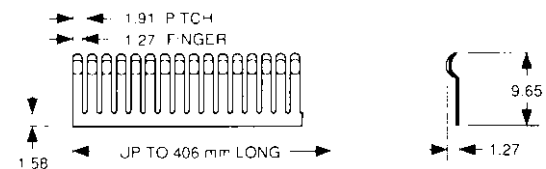

## ECP 0663

### SPHERICAL RADIUS

Elastic performance data available for specific customer gap requirements. Consult factory.

Material: beryllium copper – .16 mm thick

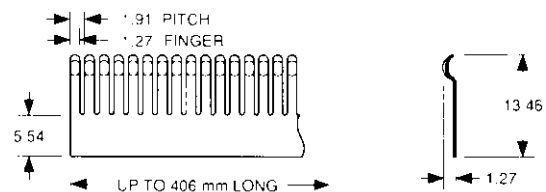

## ECP 0664

### SPHERICAL RADIUS

Elastic performance data available for specific customer gap requirements. Consult factory.

Material: beryllium copper – .13 mm thick

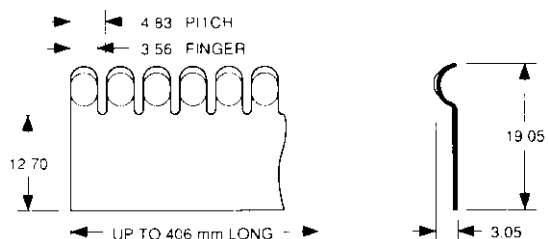

# Contact Rings

The contact rings shown here are fabricated from finger stock. These rings can be formed in any diameter containing an integral number of fingers, down to the minimum diameter to which that particular strip can be curled. This limit is spelled out in the tables of specifications under "MIN OD".

Another specification of importance in the case of contact rings is indicated on the table as dimension "E", the "recommended mounting dimension". This figure provides for the proper amount of compression against the "plug" to assure a good contact. It should be added that many variations of these rings are possible. Full information on custom forming is available on request.

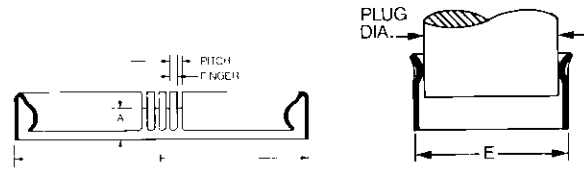

| Cat. No. | Pitch | Finger | Fingers ± 1 | Plug Dia. | Dim. E | Dim. A | Min. O.D. |
|----------|-------|--------|-------------|-----------|--------|--------|-----------|
| 60-53    | 1.52  | 1.02   | 63          | 26.98     | 30.71  | 3.18   | 12.70     |
| 93-80    | 2.36  | 2.58   | 41          | 25.40     | 31.57  | 7.93   | 24.77     |
| 93-79    | 2.36  | 1.58   | 33          | 19.05     | 25.22  | 7.93   | 24.77     |
| 93-81    | 2.36  | 1.58   | 45          | 28.58     | 34.75  | 7.93   | 24.77     |
| 127-51   | 3.23  | 1.96   | 16          | 12.29     | 16.49  | 2.36   | 16.49     |
| 127-52   | 3.23  | 1.96   | 22          | 18.64     | 23.01  | 2.36   | 16.49     |
| 127-53   | 3.23  | 1.96   | 28          | 24.99     | 29.36  | 2.36   | 16.49     |
| 127-54   | 3.23  | 1.96   | 31          | 27.58     | 31.75  | 2.36   | 16.49     |
| 165      | 4.19  | 3.56   | 12          | 8.89      | 16.18  | 6.35   | 16.18     |

| Cat. No. | Pitch | Finger | Fingers ± 1 | Plug Dia. | Dim. E | Dim. A | Min. O.D. |
|----------|-------|--------|-------------|-----------|--------|--------|-----------|
| 75-51    | 1.91  | 1.27   | 12          | 6.35      | 7.44   | 1.58   | 5.0       |
| 75-52    | 1.91  | 1.27   | 18          | 9.53      | 11.05  | 1.58   | 5.0       |
| 75-53    | 1.91  | 1.27   | 23          | 12.70     | 14.05  | 1.58   | 5.0       |
| 75-54    | 1.91  | 1.27   | 28          | 15.88     | 17.20  | 1.58   | 5.0       |
| 75-55    | 1.91  | 1.27   | 33          | 19.05     | 20.22  | 5.54   | 5.0       |
| 75-56    | 1.91  | 1.27   | 39          | 22.23     | 23.80  | 5.54   | 5.0       |
| 75-57    | 1.91  | 1.27   | 44          | 25.40     | 26.82  | 5.54   | 5.0       |
| 75-58    | 1.91  | 1.27   | 54          | 31.75     | 32.92  | 5.54   | 5.0       |
| 75-59    | 1.91  | 1.27   | 65          | 38.10     | 39.45  | 5.54   | 5.0       |
| 75-60    | 1.91  | 1.27   | 86          | 50.80     | 52.25  | 5.54   | 5.0       |

| Cat. No. | Pitch | Finger | Fingers ± 1 | Plug Dia. | Dim. E | Dim. A | Min. O.D. |
|----------|-------|--------|-------------|-----------|--------|--------|-----------|
| 134-51   | 3.40  | 2.31   | 20          | 17.04     | 22.23  | 5.92   | 17.78     |
| 134-52   | 3.40  | 2.31   | 23          | 20.22     | 25.40  | 5.92   | 17.78     |
| 134-53   | 3.40  | 2.31   | 28          | 25.78     | 30.94  | 5.92   | 17.78     |
| 134-54   | 3.40  | 2.31   | 37          | 34.93     | 40.08  | 5.92   | 17.78     |
| 134-55   | 3.40  | 2.31   | 20          | 17.04     | 22.23  | 5.92   | 17.78     |
| 134-56   | 3.40  | 2.31   | 23          | 20.22     | 25.40  | 5.92   | 17.78     |
| 134-57   | 3.40  | 2.31   | 28          | 25.78     | 30.94  | 5.92   | 17.78     |

| Cat. No. | Pitch | Finger | Fingers ± 1 | Plug Dia. | Dim. E | Dim. A | Min. O.D. |
|----------|-------|--------|-------------|-----------|--------|--------|-----------|
| 60-51    | 1.52  | 1.02   | 21          | 9.53      | 10.36  | 3.18   | 4.39      |
| 60-52    | 1.52  | 1.02   | 28          | 12.70     | 13.56  | 3.18   | 4.39      |

ALL DIMENSIONS IN MILLIMETRES

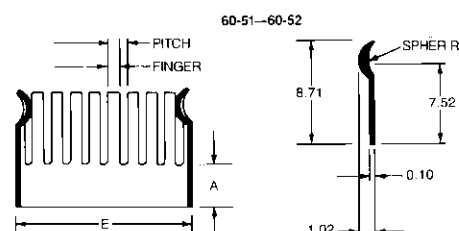
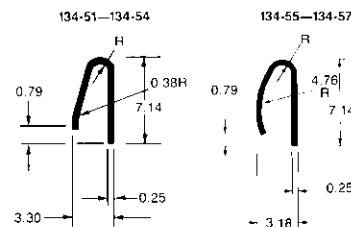
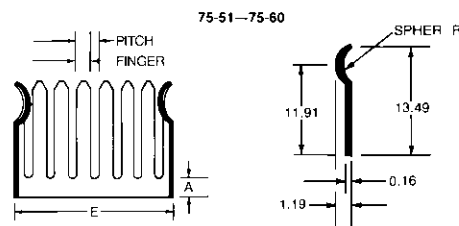
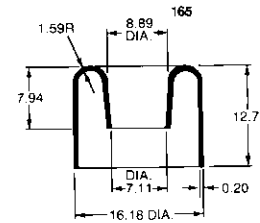
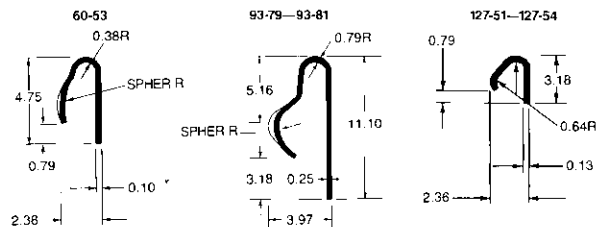

# RFI/EMI Shielding "V" Series VARIABLE SNAP-ON GASKETS



- Snap into slots
- For gaps as small as 0.5mm
- Fewer slots improve shielding effectiveness
- Easy and secure installation
- Ideal for bidirectional applications
- 100db attenuation
- 3 standard profiles with 5 slot patterns
- Low compression force
- High durability
- In stock for immediate delivery



## MOUNTING SLOT PATTERNS

"V" Series Snap-on gaskets are offered in three standard profiles, each with the five variable finger (or slot) patterns shown below.\* Strips may be supplied to any full- or semi-finger increment.

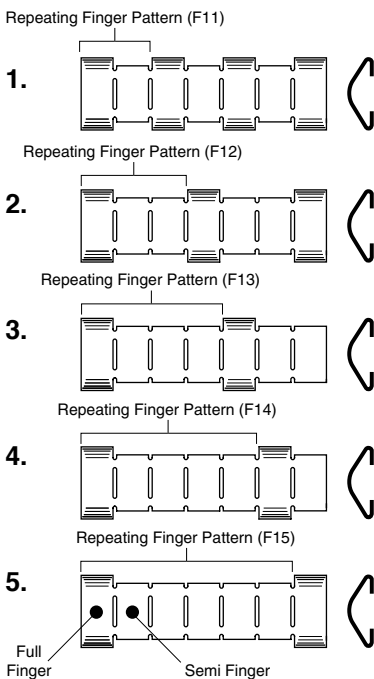

## ECP612VFXx (Shown with pattern F11)

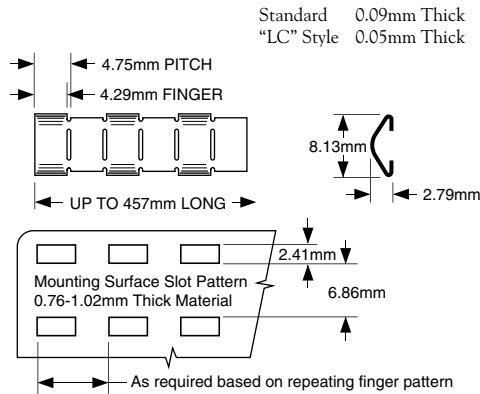

## ECP614VFXx (Shown with pattern F11)

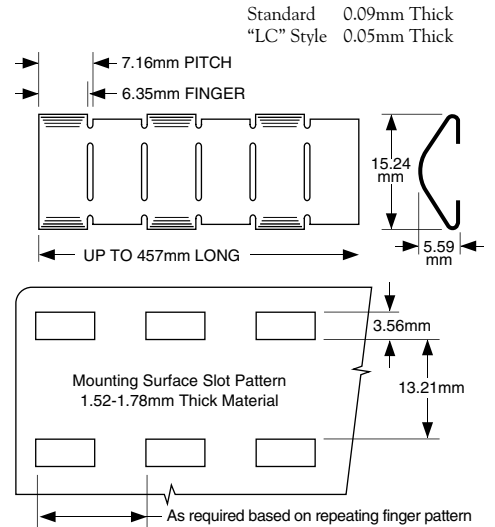

## ECP613VFXx (Shown with pattern F11)

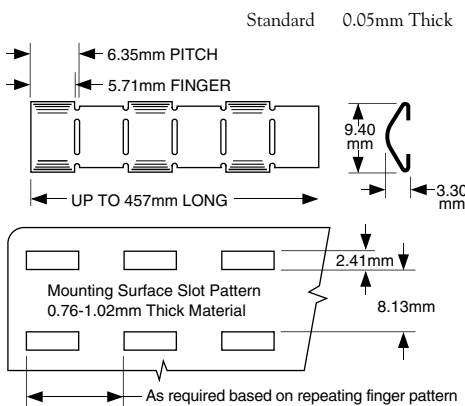

# CARD CAGE SHIELDING

TBA-PS's new card cage shields are designed to provide contact between the card cage and the I/O slot brackets for optimum EMI/RFI shielding effectiveness

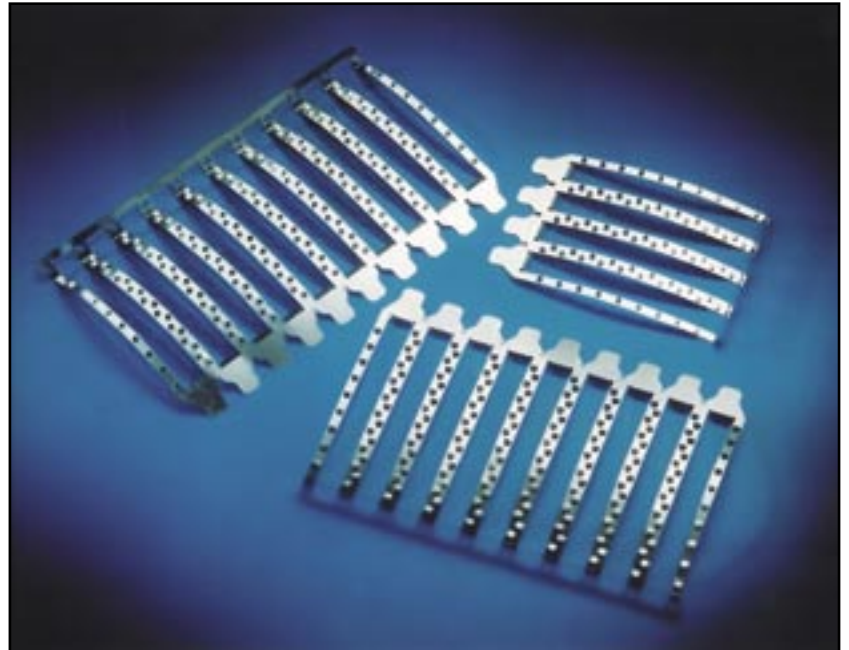

Produced from 0.076mm stainless steel

19 contact fingers per slot

Contact fingers to static side, facing the card cage portion of the chassis allowing easy insertion of add-in cards without snagging.

Multiple slot configuration. 1-10 slots without tooling

Available as standard items 1-10 slots



Unit 3, Transpennine Trading Estate,  
Gorrells Way, Rochdale OL11 2PX

Tel. +44 (0)1706 647718

Fax. +44 (0)1706 646170

email. [info@tbaps.com](mailto:info@tbaps.com)

**[www.tbaps.com](http://www.tbaps.com)**

