

## Installation and Operation Manual for the SupaTite End Restraint Coupling



Deviation from this manual releases Cascade Clamps UK Ltd from responsibility and warranty.  
Due to the constant development of the company we reserve the rights to modifications and changes  
to the construction of the product.



## Contents:

1. Technical specification.....	3
Product name.....	3
Application .....	3
Technical characteristics .....	3
2. Construction .....	4
Dimensions.....	4
Materials .....	4
Standards .....	5
Marking .....	5
Protection.....	5
3. Installation manual .....	6
4. Placing the order.....	7
5. Storage.....	7
6. Transportation .....	7
7. Health and safety.....	7
8. Warranty conditions .....	7



## 1. *Technical specification*

### **Product name**

SupaTite End Restraint Pipe coupling DN350 - DN2000 PN10 / PN16.

### **Application**

Connections between plain ends of PE/PVC pipes, cast iron, steel and asbestos-cement AC pipes – plumbing (potable water), sewage, industrial pipelines and other liquids chemically neutral.

### **Technical characteristics**

Temperature - max. 120 °C.

Nominal pressure 10 / 16 [bar].

Seal: EPDM or NBR.

Anti-corrosive epoxy powder coating RAL 5005, ~250µm, acc. to PN-EN 4624:2004.



## 2. Construction

### Dimensions

DN	Range Dmin-max [mm]	Height A[mm]	Width B[mm]	Weight [kg]
350 PE/PVC	353 - 407	320	504	31
350	348 - 362	320	470	28
350	371 - 385	320	494	30
400 PE/PVC	443 - 457	320	562	32
400	399 - 413	320	522	31
400	422 - 436	320	545	33
450 PE/PVC	493 - 507	320	604	34
450	473 - 487	320	596	36
500 PE/PVC	553 - 567	320	656	42
500	501 - 515	320	620	39
500	525 - 539	320	648	41
600 PE/PVC	623 - 637	320	742	47
600	603 - 617	320	722	46
600	628 - 642	320	750	48
700 PE/PVC	703 - 717	320	825	55
700	704 - 718	320	825	55
700	731 - 745	320	854	57
800 PE/PVC	793 - 807	320	915	65
800	806 - 820	320	925	68
800	835 - 849	320	958	70
900 PE/PVC	893 - 907	320	1030	79
900	907 - 921	320	1030	83
900	938 - 952	320	1060	85
1000 PE/PVC	993 - 1007	320	1130	96
1000	1009 - 1023	320	1130	97
1000	1041 - 1055	320	1160	99
1200	1213 - 1227	420	1230	115
1200	1248 - 1262	420	1260	117

No.	Name	Material	Standard
1	Rim	S235JR	PN - 88
2	Restraining Screw M16	S235JR Galv	ISO 8677
3	T-Rim	S235JR	PN - 88
4	Bolts	S235JR Galv	ISO 8677
5	Seal	EPDM / NBR	WRAS
6	Body	S235JR	PN - 88

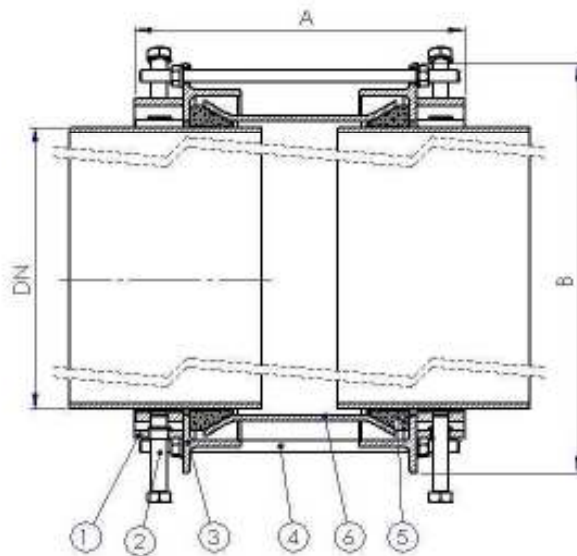

### Materials

NO	NAME:	MATERIAL:	STANDARD:
1	Rim	S235JR	PN - 88
2	Restraining screw M16	S235JR Galv	ISO 8677
3	T-Rim	S235JR	PN-88
4	Bolts	S235JR Galv	ISO 8677
5	Seal	EPDM / NBR	WRAS
6	Body	S235JR	PN - 88



## Standards

PN - 88/H-84020  
ISO 8677  
PN - 92/C - 01604.01

Carbon, constructional steel of common application - types  
Cup head square neck bolts with large heads.  
Rubber - Terminology - Division, the names and symbols of rubber.

## Marking

SupaTite End Restraint Pipe couplings are marked with label, which contains following information:

- Nominal diameter DN,
- Nominal pressure PN,
- Manufacturer's logo.

## Protection

Coatings: All the joint's surfaces, internal and external, are protected with epoxy powder coating laid on electrostatically. The coating is WRAS approved to be in contact with potable water.

The joint's surfaces are prepared to be covered with the epoxy paint acc. to the technical documentation and PN-EN ISO 12944-5: 2001.

Bolts connecting the cover ring with the body, unless they are stainless steel (e.g. OH18N9 / A2), are to be galvanised (S235JR Galv) PN-8.8 Standard.

### 3. Installation manual

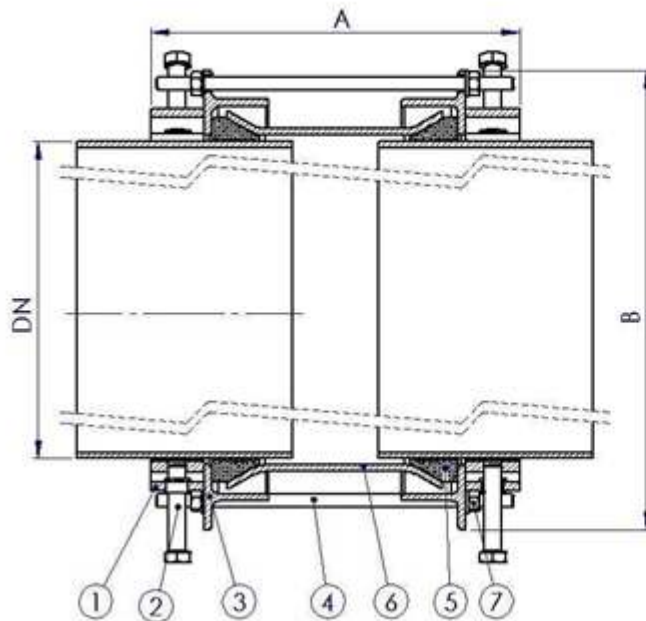

No.	Name
1	Rim
2	Restraining Screw M16
3	T-Rim
4	Bolts
5	Seal
6	Body
7	Nut

1. Prior to assembly of SupaTite End Restraint type Couplings check if both ends of the pipeline are co-axial.
2. Make sure that the outside diameter of pipe is within the tolerance of sealing.
3. The outside surface of the pipe on which the product is assembled, should be free from any dirt or obstructions and should be smooth.
4. Before sliding the fitting onto the pipes' ends, make all bolts (4) and nuts (7) loose until they allow easy sliding of the fitting onto the bare ends of connected pipes.
5. Slide the fitting onto the pipes and set the fitting in place so that it is fully in line with pipe axis.
6. Leave the gap between the ends of the pipes inside the coupling of C=30-60mm. Make sure that the end of the pipe is min. 15mm further than the seal (5).
7. Start tightening the nuts (7) gradually working on diametrically opposed nuts, in successive stages (two or three turns at a time), causing even tightening of the rim (3) and rim's sealing (5) to the fixed pipe. Max. torque for the bolts (4) is 60Nm.
8. Fastening of end-restraints.  
Fasten the bolts (2) - start from the main axis of the pipeline and work your way around the pipe in symmetrical manner causing gradual and even tightening of the restraining element to the pipe in all its diameter.

Screw the restraining elements gradually:

1 step - use ca. 70Nm and tighten all the elements crosswise, 2 step - use ca. 95Nm and tighten all the elements crosswise, 3 step - max. use 120Nm.

Max. torque to tighten the end-restraints is 120Nm.

9. Examine the assembled fitting and check the connections thoroughly. Make all necessary corrections when needed (fasten the bolts and nuts).

The max. torque for all the bolts (4) and nuts (7) is 60 Nm.

The nuts are to be tightened diagonally, alternately and gradually – applying the steady torque stress in each bolt.



## 4. Placing the order

On placing the order please provide the following information:

- Product full name,
- Nominal diameter DN,
- Outside diameter of the pipe on which the pipe coupling will be installed,
- Bolts material: galvanised / stainless steel.

## 4. Storage

The joint is not to be stored in the places where the following factors occur:

- Direct influence of sunshine,
- Oil, petrol or grease.

## 5. Transportation

SupaTite End Restraint Couplings should be lifted using the manual handling operations regulations 1992, and should be secured safely when transporting to avoid damage or injury.

## 6. Health and safety

The guidelines stated in health and safety regulations for the installation of pipelines and equipment in the water treatment plants and in the other plants apply in case of installation of the joints. Operation not withstanding with the recommended application is not allowed.

## 8. Warranty conditions

The manufacturer warrants proper operation of the product manufactured and operated according to the Installation and Operation Manual relating to this product.

Limitation of Liability: The company shall not be liable for any claim arising out of performance, non-performance, delay in delivery of, defect in the goods nor for any special, indirect, economic or consequential loss or damage however arising or howsoever caused (including loss of profit or loss of profit or revenue) Whether from negligence or otherwise in connection with the supply, functioning or use of the goods. Nothing herein shall limit either parties liability for death or personal injury arising from the proven negligence by itself or its employees or agents. The client shall fully indemnify the company against any liability to third parties arising out of clients use of the goods. Liability is limited to the replacement of faulty goods only and no other claims.