



OPERATIONAL AND MAINTENANCE MANUAL

MOD 14-02

Rev. 0

Data 01/02/2012

**Drilling machine  
ProDrill 20**

**INSTRUCTION MANUAL  
FOR USE AND MAINTENANCE**

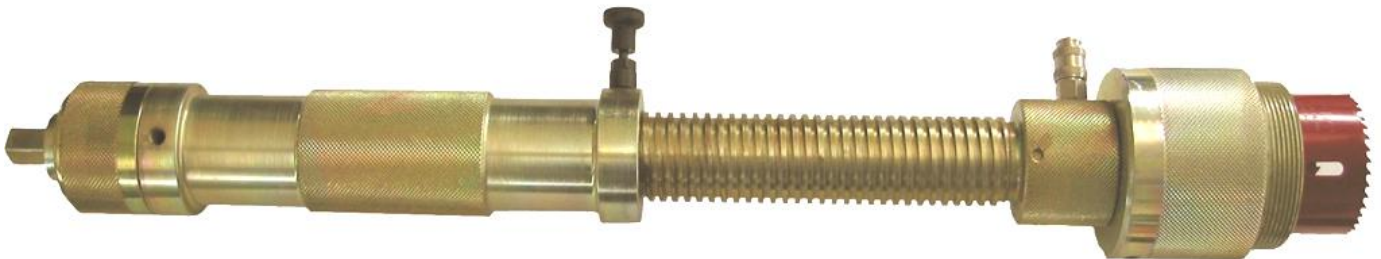

**TABLE OF CONTENTS**

<i>TECHNICAL SPECIFICATIONS</i>	2
<i>USE</i>	4
<i>MAINTENANCE</i>	8
<i>WARNINGS</i>	8
<i>WARRANTY</i>	9

## TECHNICAL SPECIFICATIONS

The drilling machine is fabricated from steel and is protected by a double zinc coating. It is suitable for drilling holes in low and medium pressure gas and water pipes, 16 bar max, with excellent results and in complete safety.

The drill has the following features:

- Variable working stroke, 160mm as standard, 150mm and 350mm extensions are available
- Drill bits with coupon catcher are available
- Vent valve on the machine
- Hole saw cover
- Safety limit switch
- O-ring pressure
- **Machine body bearing is protected by a lip seal lip inserted in the bush**
- The drilling machine is supplied in a metal case with a set of hole saw which; are available in the following diameters:
  - Diametro ½" Drill ø12 mm.
  - Diameter ¾" Saw ø17 mm.
  - Diameter 1" Saw ø22 mm.
  - Diameter 1¼" saw ø30 mm.
  - Diameter 1½" saw ø37 mm.
  - Diameter 2" saw ø48 mm.
  - Diameter 2½" saw ø64 mm.
  - Diameter 3" saw ø73 mm.
  - Diameter 4" saw ø98 mm.
  - Diameter 5" saw ø121 mm.
  - Diameter 6" saw ø140 mm.

The box containing the drilling machine includes all the accessories necessary for setting up and operationing the drill machine, these are listed below:

- Cup holder and hole saws ¾” to 2”
- 1 extension port hexagonal hole saws cutter type AT or TAD
- (or) No. 2 spindles for precision hole saws type AV (without shank hex)
- 2 extensions 150 and 200 mm for art. 22
- 1 extension of 50 mm (only for item 20).
- 1 point for centering
- 2 lever assembly / disassembly extensions
- 1 piston discharge pressure
- 1 screwdriver, only to hole saws with model type TA and TAD (Hex Shank)
- 1 Allen key 3 mm (for art.20)
- 1x 4 mm hex key (for art.22-26-35)
- 1 ratchet crank
- 1 Key
- 1 instruction operational / maintenance.

## OPERATION

1. After removing the machine from the box remove the hole saw and **the cutter holder holder**, need not remove the lid that covers the saw, attach the cutter holder holder when you screw it up to seal against the O-ring. Then tighten with the wrench. (fig. 1).

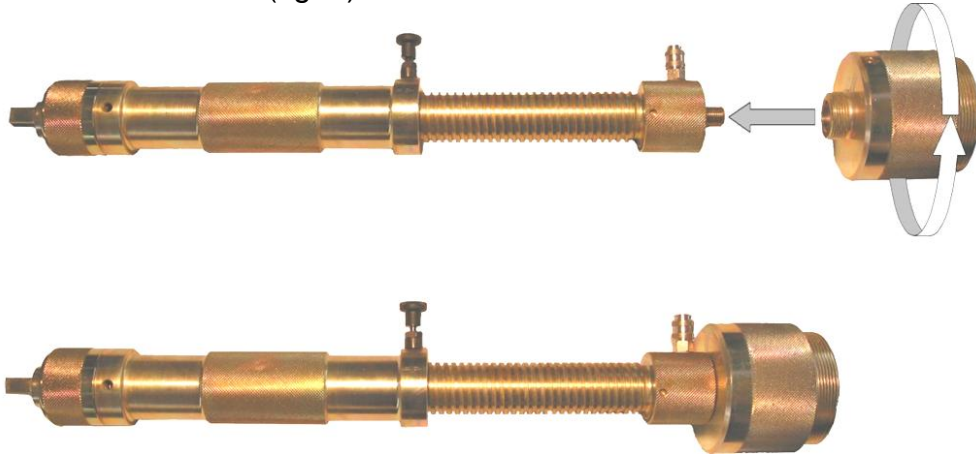

Fig 1

2. Screw the **outer cover** up to let out the shaft and mount the milling hexagonal extension (if using T-saw with the stem hex) or the milling precision hole saws without stem AV type hexagonal (Fig. 2). Close at the same time using the lever assembly / disassembly and ratchet.

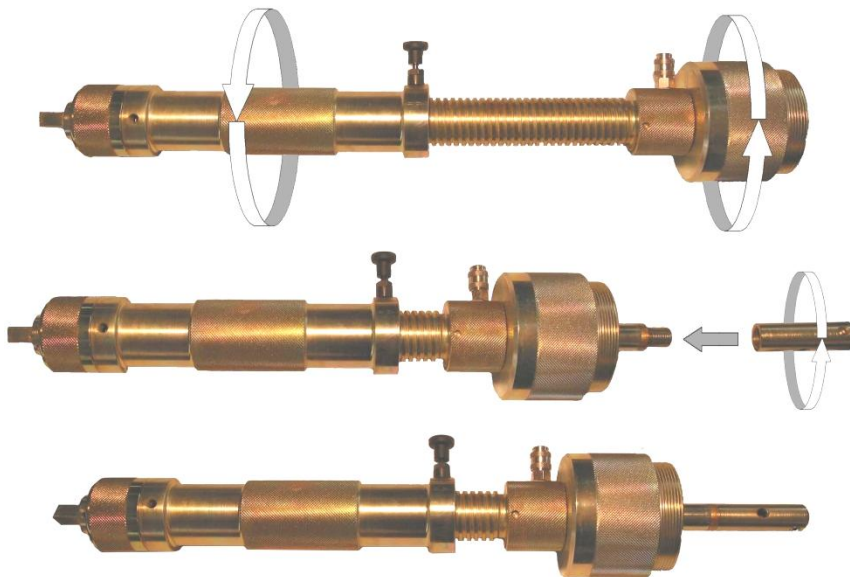
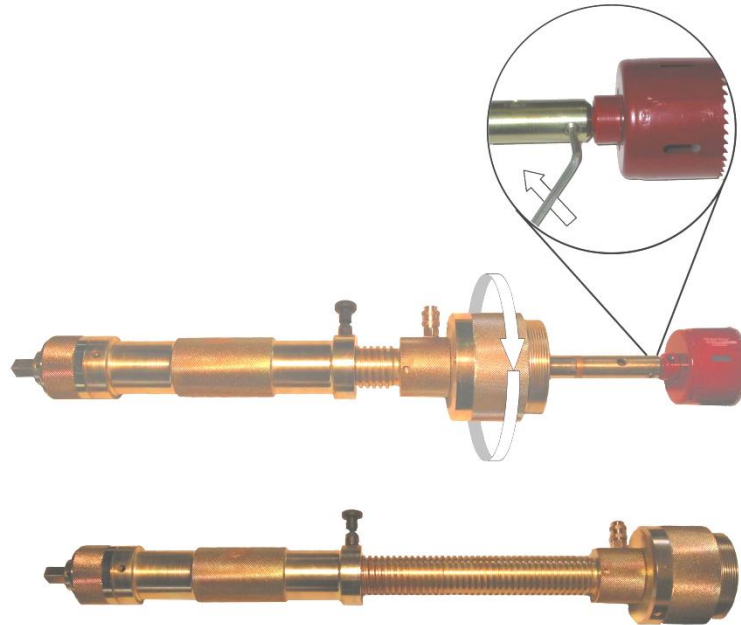

Fig 2

3. Attach the hole saw without removing the lid cover, and close it with the the hex wrench, tightening the Allen screw on the extension (Fig 3.) Remove the cover and turn the cutter counter clockwise to unscrew the saw from the cutter older (Fig. 3).



**Fig 3**

4. Screw on the valve or the cutter holder holdersleeve on the tube already prepared. To improve the grip, you can isolate the part of connection with teflon or hemp.
5. Check that the valve is open and start screwing up the inside of the outer sleeve.
6. Perform, then, the center bore using the ratchet. When the pilot drill bit begins to penetrate the inside of the tube, the pressure gauge on the valve to vent the machinerises sharply at the level of pressure in the pipe. At this point it is necessary to reduce the manual feed, thus avoiding the risk of breaking the tip.
7. Control of the center bore, continue to tighten until the hole saw comes in contact with the pipe. After obtaining the optimal drilling pressure, to act with the ratchet or pneumatic motor, until they are Sawt the surface of the tube. During construction of the centre bore and drilling is recommended to maintain a regular feed to avoid tool breakage.

8. Drill hole, remove the machine in order to return the hole saw into the cutter holder. The safety lock ensures that the compass does not protrude outside of the machine causing danger to the operator. Close the valve on the tube and release the pressure by using the special low pressure piston (Fig. 4).

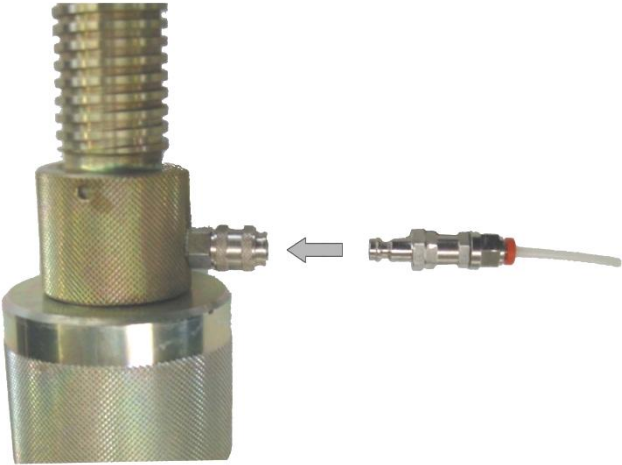

**Fig 4**

9. After removing the valve from the machine, place it on the ground and remove the cutter holder holder with the lever assembly and a ratchet. To start unscrewing give a rap with a hammer to the lever assembly located in the hole of the extension, holding at position shown in Fig. 5. Remove the tiller extension port, the cutter holder and the hole saw

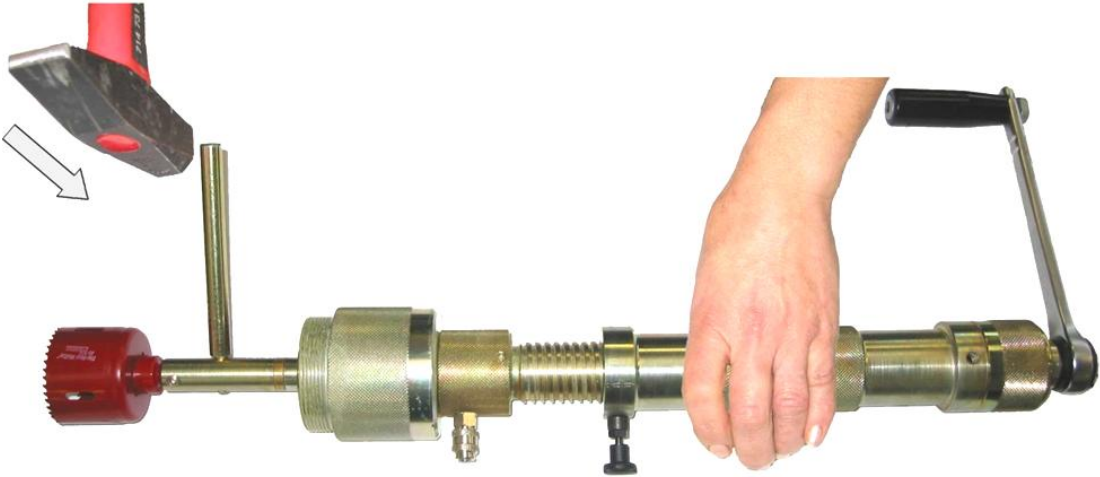

Fig 5

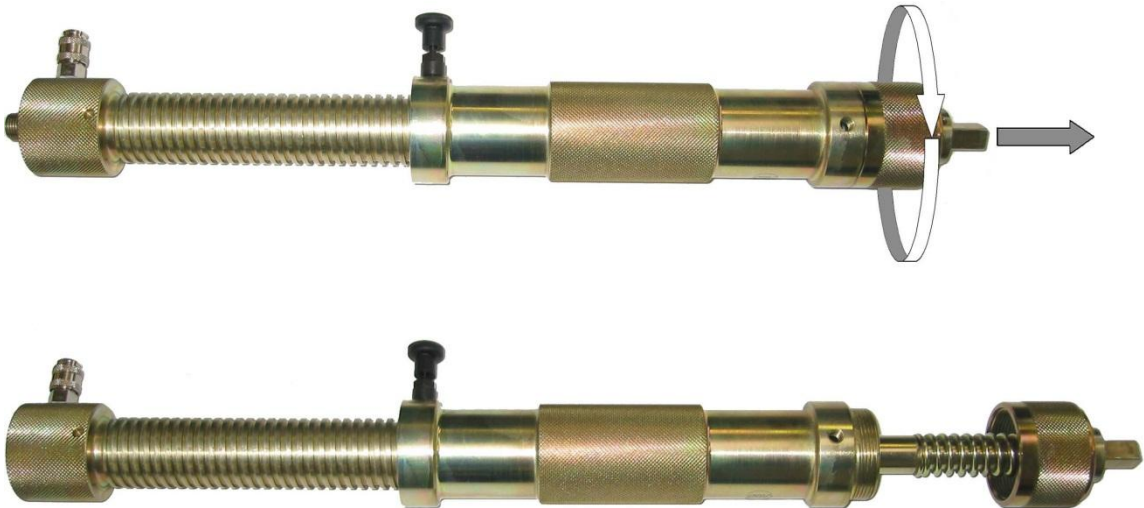

Fig 6

## MAINTENANCE

1. Before being placed in the box all parts of the machine should be cleaned with a dry cloth and the the main shaft lubricated with a silicone spray.
2. Every 4-5 well drilling operations disassembling the machine.
  - Remove the central shaft
  - Clean the inner housing
  - Grease the roller bearing in the seat of the car cutter holder holders
  - Check that the O-rings are in good condition and lubricate
3. When in the course of a puncture is found that the tree little cutter holder holder opposes cutting pressure and the top of the machine gets up to 1-1.5 cm, to obtain a sufficient drilling is necessary to replace the internal spring that regulates the drilling pressure.
4. If holes are found during a loss, check the O-rings and replace if necessary. Also check that the central shaft has not been deformed.

## WARNINGS

- Wear appropriate protective clouthing when using the drilling machine shoes, gloves, etc. ..).
- Take care when lifting and moving, especially for the heavier models.
- The manufacturer assumes no responsibility 'for damage to persons, animals or property caused by improper use of the drilling machine.

**Never stand over or cover the drill with any part of your body when drilling under pressure.**

**Do not attempt any drilling if you are not familiar with the methods or procedures. It is always beneficial to undertake a training schedule.**



## **GUARANTEE**

The machines supplied are guaranteed for 12 months from the date of sale for defects: materials, processing, editing.

The company reserves the right to replace under warranty at its own expense the items that are defective following a technical review . Items that have undergone normal wear and tear, such as hole saws or drills centering and everything is considered consumable.

The guarantee will not apply if:

- repairs were carried out with related parties are not original or adapted, or modified
- The product is modified or used in applications too cumbersome or use other than its unnatural.