

Sondaloop and MiniSonda Version 2

Ultrasonic Level Transmitter

Installation & Setting up Instructions



Hawker Electronics Limited

57 The Avenue
Rubery Industrial Estate
Birmingham B45 9AL
Telephone + 44(0)121 453 8911
Fax +44(0)121 453 3777
Email: info@hawker-electronics.co.uk
Web: www.hawker-electronics.co.uk

O&M 82
Issue H
APR 2017



FM 10000

Contents

1.0	OVERVIEW	3
2.0	SONDALOOP MODELS AND SPECIFICATIONS	3
2.1	General specifications and dimensions	4
3.0	INSTALLATION	5
3.1	General do's and don'ts.....	5
3.2	Positioning the Sondaloop.....	6
3.3	Using a stilling pipe.....	8
4.0	MOUNTING	9
5.0	ELECTRICAL CONNECTION	9
5.1	Connection Diagrams	11
6.0	SCALING THE LEVEL FOR DEPTH OR DISTANCE.....	12
6.1	Setting the Sondaloop to measure DEPTH	12
6.2	Setting the Sondaloop to measure DISTANCE	13
7.0	PROGRAMMING THE SONDALOOP	13
8.0	TROUBLE SHOOTING	18
	Declaration of Conformity.....	19

Introduction

These instructions are for the Sondaloop, the Sondaloop Remote and the MiniSonda.

The instructions for setting up these ultrasonic instruments are broadly identical, so we only mention the Sondaloop for simplicity of understanding. Where specific mention is needed for the Sondaloop Remote and the Minisonda then we have done so.

1.0 OVERVIEW

The Sondaloop is a loop powered 2-wire ultrasonic transmitter with a user programmable measuring range of up to 8 metres. The integral LCD can display the measurement as a depth or distance (user configurable). The output of the transmitter is a 4 to 20mA current which is linearly proportional over the programmed range.

The Sondaloop works by sending out ultrasonic sound waves from its sensor, the sound waves reflect off the surface of the liquid in the vessel and return back to the sensor. The time taken to perform this process is calculated and then converted to provide a measurement in metres.

The Sondaloop is temperature compensated as the speed of sound varies with temperature.

If the Sondaloop does not receive an echo (Lost Echo) it can be programmed to transmit various current outputs as a fail safe feature including a 21mA alarm signal if required.

Underneath the screw-on cap is a 4-digit LCD and keypad.

2.0 SONDALOOP MODELS AND SPECIFICATIONS

The Sondaloop v2 is available as three different types to suit specific applications.

Sondaloop

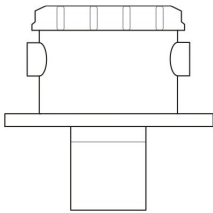

Comprises a polypropylene enclosure to IP66 with a universal flange; under the screw on lid is a LCD and keypad.

The UPVC sensor is factory fixed to the bottom of the enclosure.

Sondaloop Remote

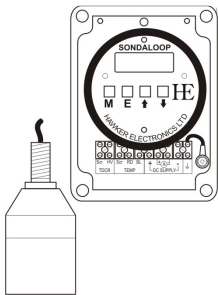

Separate UPVC sensor and electronics by up to 15 metres, c/w integral twin cables. The electronic display and keypad are housed in a clear polycarbonate enclosure to IP66. The remote sensor is to IP68.

MiniSonda

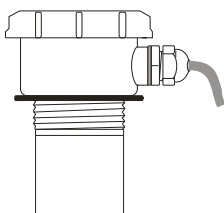

Comprises a polypropylene enclosure to IP66 with a 2" BSP fitting; under the screw on lid is a LCD and keypad. The UPVC sensor is factory fixed to the bottom of the enclosure.

2.1 General specifications and dimensions

Model	MiniSonda	Sondaloop	Sondaloop R1
Measuring Range	0.4 to 8 metres	0.4 to 8 metres	0.4 to 8 metres
Output	4-20mA into 250 ohms @ 24VDC or 850 ohms @ 38VDC		
Loop Voltage	20 to 38VDC reverse polarity protected		
Power required	0.5Watts @ 24VDC		
Resolution	1mm		
Accuracy	0.25% of measuring range (electronic)		
Display	4 digits		
Minimum span	100mm		
Lost Echo	User programmable 4, 20,21mA or hold last valid reading		
Temp. compensation	Built in digital sensor		
Ultrasound frequency	50KHz \pm 10%		
Op. temperature	-10°C to +60°C		
Weatherproof	IP66	IP66	Controller IP66. Sensor IP68
Cable Gland thread	M20	M20	N/A
Cable	2 core screened		
Mounting	2" BSP	Universal flange ANSI 3" 150lb DN80 PN16 BS10 Table D 3" Type 81 Bracket	Sensor 3/4 inch BSP Electronics screw/DIN
Cone angle	12° included		
Pressure	-0.25 to + 2 Bar @ 20 degrees C		
Construction Materials			
Housing	Polypropylene	Polypropylene	Polycarbonate
Sensor	UPVC	UPVC	UPVC

Fig 2.1 MiniSonda

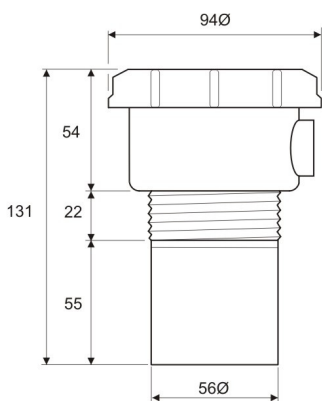

Fig 2.2 Sondaloop

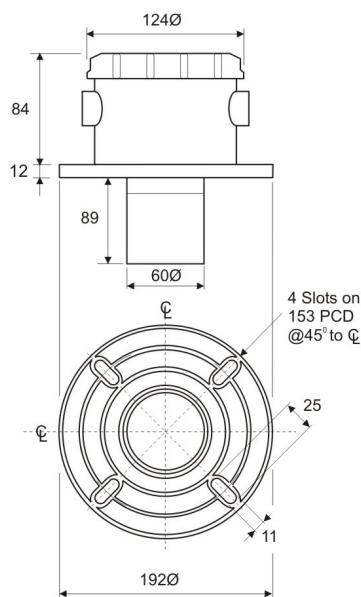
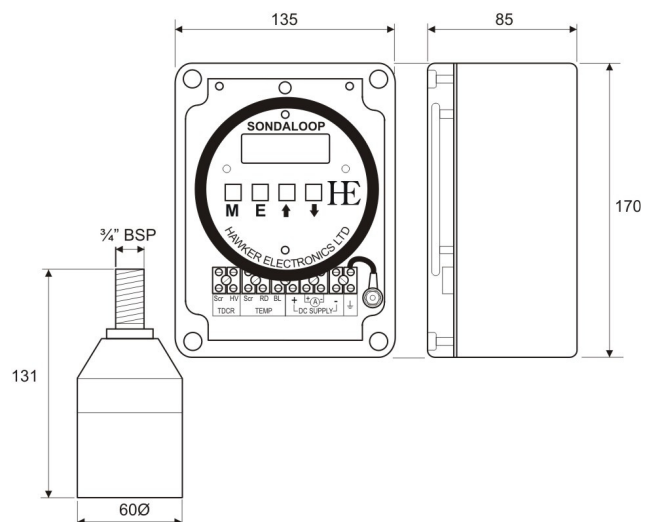

Fig 2.3 Sondaloop Remote R1



Dimensions in mm unless stated otherwise

3.0 INSTALLATION

The installation must be performed by a competent person in accordance with the applicable code of practice and local regulations.

Maintenance

The non contact nature of the technology keeps the sensor out of the material therefore generally no maintenance is required. Should the outer body or sensor require cleaning the use of a mild detergent is recommended. Care should be taken not to damage any labels.

The Sondaloop contains NO USER SERVICEABLE PARTS and no attempt should be made to dismantle, repair or alter the equipment in any way.

3.1 General do's and don'ts

Check before installing:

1. The Sondaloop has a 'dead band' of 0.4m from its sensor face. Ensure that the highest liquid level does not enter this 'dead band'. Liquid closer than 0.4m will result in false measurements. See section 3.2 point 2.
2. With the vessel empty ensure the signal path under the Sondaloop is clear of obstructions. Obstructions will provide return echoes and will be mistaken for the liquid level, see 3.2.
3. Where possible always mount via a plastic fitting or other synthetic material, try to avoid mounting directly to a metal surface. Always use the supplied gasket between the body of the unit and the fitting.
4. Ensure there are no aggressive substances i.e. acidic liquids, vapours or gasses in the application that may attack the enclosure materials or PVC sensor.
5. Vapours and fumes will affect the sensor accuracy, if the concentration is consistent providing a stable environment then the instrument will function normally, but if variations are present or there is atmospheric stratification the instrument accuracy will be affected. An example where vapour is often found is acetic acid.
6. Ultrasonic transmitters do not work well when foam is present, as it attenuates the ultrasound thus preventing a reasonable echo returning to the sensor. If foam is present, and it is not possible to avoid, then a 'stilling pipe' should be used, see 3.3.
7. Turbulence and splashing can result in erratic readings; if this cannot be avoided consider using a 'stilling' pipe, see 3.3.
8. Take care not to mount the Sondaloop over any inlet as incoming liquid will be sensed by the Sondaloop resulting in a false reading.
9. Do not use the Sondaloop where condensation is present, as it may collect on the sensor and cause errors.

10. If the sondaloop is mounted in an enclosed tank, do not mount the instrument in the centre of the tank as dished tank ceilings can act as parabolic reflectors. This means that the transducer will be the focal point and will receive amplified false echoes. It is usual to mount at about $\frac{1}{2}$ vessel radius from the centre.
11. Environments exposed to direct sunlight for long periods generate very hot surfaces; if the product is likely to be exposed to these conditions use a sun screen.
12. Environments exposed to rain or jet wash cleaning may increase the chance of liquid entering the product causing malfunction. Avoid this by fitting a rain/water shield. Always fit the products screw on top cap.

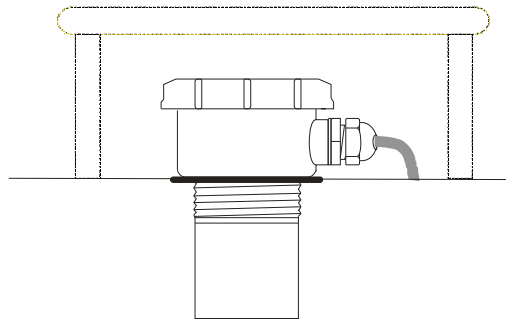

13. Liquids will track along a downward going cable. To prevent liquid entering the product via its cable gland ensure a tight connection and always check the cable exiting the gland is in a general downward direction. Do not put pressure on the cable where it exits the gland. Do not make sharp bends in the cable.

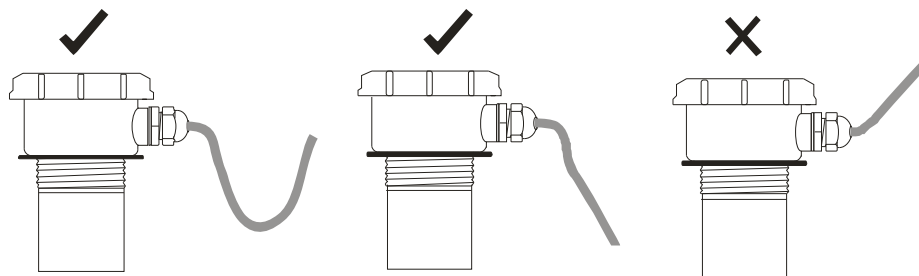

14. The Sondaloop complies with national regulations on Electro Magnetic Compatibility however it is recommended that the instrument is not located in close proximity to other sources of electrical noise e.g. inverter drives, welding equipment or close to electrical distribution power lines.

3.2 Positioning the Sondaloop

1. The Sondaloop has a beam angle of 12° to the half power point (3dB). The ultrasound is transmitted from the sensor in a cone shape, **this inclusive cone shaped area must be clear of obstruction otherwise the Sondaloop will receive echoes from the obstructions and not the liquid.** The total beam coverage area can be calculated as shown in Fig 3.1 measurement 'B'. Even small obstructions such as small diameter pipes, seams and protrusions can generate strong 'false' echoes.

If the ultrasonic signal overlaps the inside wall of the vessel the echo will still be valid but of a lower amplitude, however problems arise when the internal vessel wall is not smooth i.e. has protrusions or seams as is often the case, so it is advisable to mount so the beam does not overlap the vessel wall as shown in Fig 3.1. To avoid false echoes from the side wall or other obstructions the ultrasonic sensor should be mounted at least 0.11m per

metre of maximum range away from the obstruction, measured from the centre line of the Sondaloop, see Fig 3.1 measurement 'A'. If this is not possible it may still be possible to obtain good measurements provided the liquid has a good reflective surface but there must always be a minimum spacing of 0.4m from the sensor to the tank wall.

Remember it is important to visually inspect the vessel when it is empty to ensure there are no obstructions (i.e. pumps or stirrers) that would be unnoticeable when the vessel is full. If obstructions can't be avoided consider using a 'stilling tube', see section 3.3.

Fig 3.1

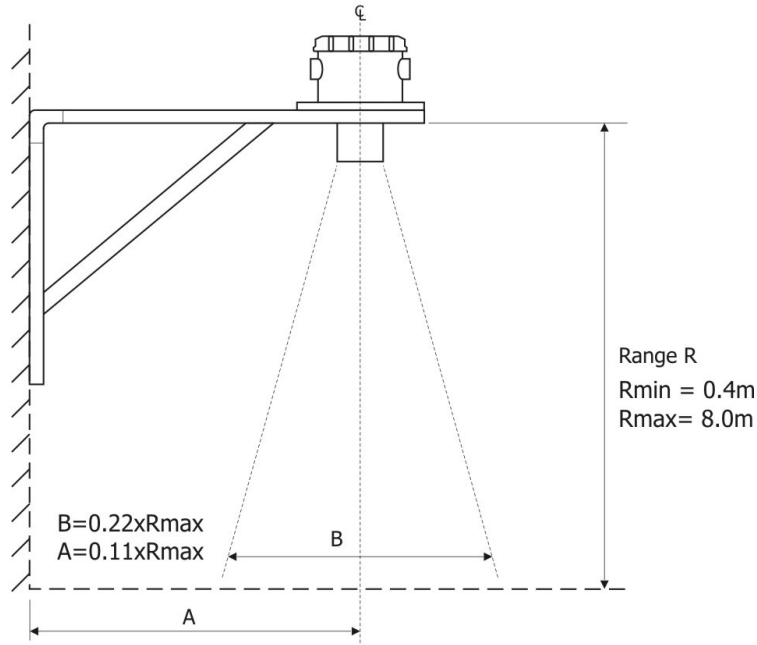

2. The Sondaloop has a 'dead band' of 0.4m from its sensor face. Ensure that the highest liquid level does not enter this 'dead band'. Liquid closer than 0.4m will result in false measurements, which may appear as distances several times the real liquid level.

Fig 3.2

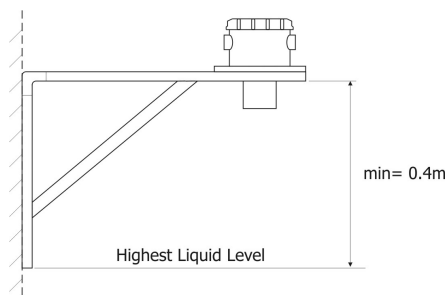

If the vessel is being totally filled the 0.4m clearance requirement can be obtained by using a 'stand off' pipe, this moves the physical position of the Sondaloop above the vessel.

Fig 3.3 Stand off pipe

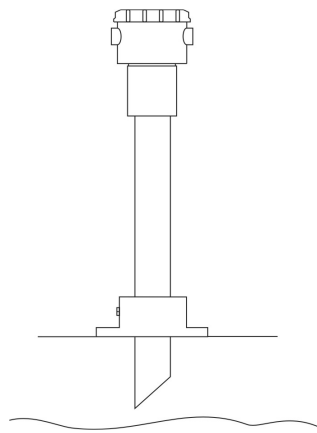

1. Must be completely smooth inside with no seams or protrusions.
2. Recommended minimum 100mm internal diameter
3. End of pipe must be cut off at a 45° angle
4. The maximum length is 0.5m
5. Drill a small diameter hole at top of pipe to let any trapped air escape

Sometimes vessels have an existing 'stand off' that may be used (also referred to as a 'nozzle or 'top hat' arrangement). It is always best if the sensor protrudes into the main vessel body but if it doesn't the instrument should be mounted as Fig 3.4. Ensure the inner surface is completely smooth and free of any seams or protrusions.

Fig 3.4

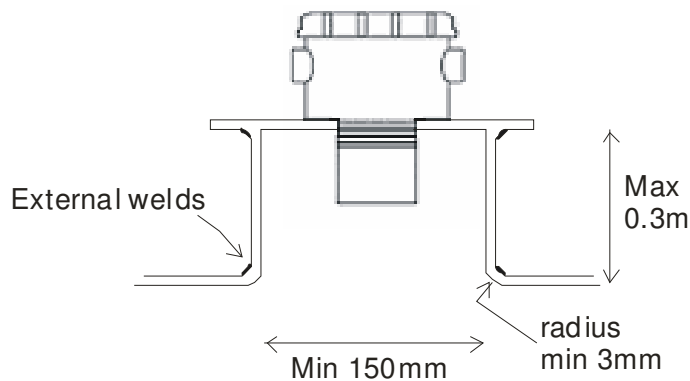

3.3 Using a stilling pipe

A stilling pipe can be used to overcome foaming liquids and obstructions which otherwise would be sensed by the Sondaloop.

It is important that the internal wall of the stilling tube is smooth and free from seams and protrusions.

When foam is present it is preferable that the end of the stilling tube is never allowed to become uncovered thus preventing foam from entering the tube. Where a stilling well is used to avoid an obstruction the stilling well must be at a lower level than the obstruction.

Stilling wells can be used in clean liquids only as dirty liquids will contaminate the inside of the well. The pipe should have a minimum internal diameter of 100mm, and an air vent hole drilled at the top to relieve the pressure built up in the pipe as it fills with liquid.

Fig 3.5

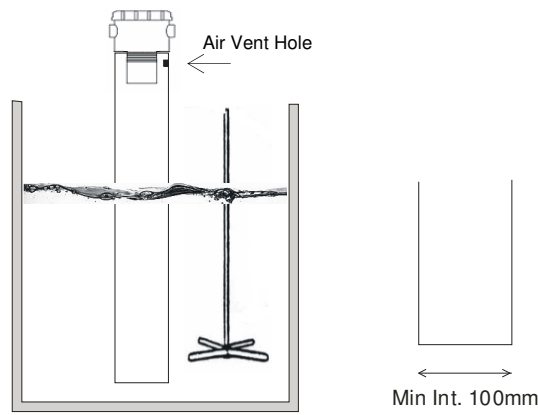

4.0 MOUNTING

It is essential to mount the instrument (or sensor on a remote model) correctly to ensure reliable operation.

1. Metal nuts and bolts should not be used to fasten the Sondaloop to a vessel or mounting bracket as it may cause unwanted 'ringing' resulting in erratic operation, most often seen as the output current and LCD reading ramping up and down. The flanged Sondaloop is supplied with plastic mounting nuts and bolts and rubber washer. The MiniSonda should be screwed into an intermediate non-metallic fitting. Hawker Electronics offer a PVC threaded disc and variety of stainless steel angle brackets. On The MiniSonda PTFE tape can be used on the thread if necessary and hand tight is sufficient, be careful not to over tighten.
2. Always ensure the sensor is perpendicular to the liquid surface to ensure the best possible quality of echo.

5.0 ELECTRICAL CONNECTION

The Sondaloop & MiniSonda (excluding the Sondaloop Remote R1) has only 2 electrical connections these are +VDC and -VDC, which connect to the user's power supply. The output current that represents the level in the vessel¹ can be monitored in series with either of these leads.

¹After the Sondaloop has been programmed

The Sondaloop will operate with as little as 19VDC but with 19VDC only the LCD will work and there will be very little current output, making it unsuitable for most applications. The minimum permissible supply voltage is dependant on the resistance of the user's installation. If the supply voltage to the Sondaloop is too low there will not be sufficient drive to produce a current, and consequently any externally connected equipment will not display the correct readings. This resistance comes about from the supply cables and the resistance of any external equipment, for example a plc and moving coil display meter, see Fig 5.1.

Fig 5.1

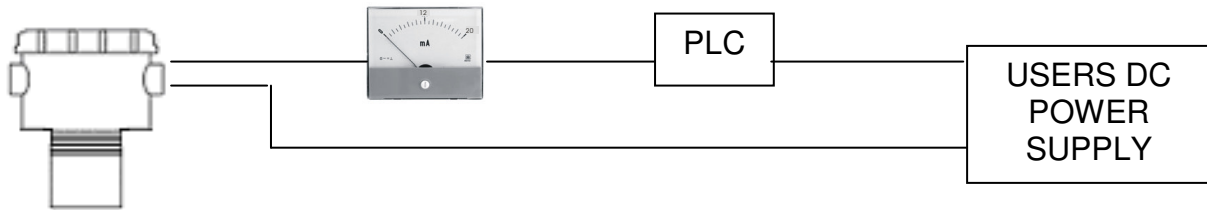

Using Fig 5.1 as an example the installation resistance is calculated:

Ammeter	100 Ohms
PLC	250 Ohms
Cable	20 Ohms (10 Ohms per leg)
Total	370 Ohms

To calculate the minimum required DC power supply voltage, use the formulae $V=IR$:

So assuming we need to drive a maximum current of 20mA (20mA is 0.02A) then:

$$V = 0.02 \times 370$$

$$V = 7.4$$

$$V_{\text{power supply}} = 19 + 7.4 \quad (\text{where } 19\text{V is a constant, the minimum volts necessary for the Sondaloop to operate})$$

$$V_{\text{power supply}} = 26.4\text{V}$$

So the installation above requires a DC Power Supply which has a minimum output of 27VDC (rounded up). Of course a power supply with an output greater than this could be used provided it does not exceed 36VDC (36VDC is the maximum supply to the Sondaloop), this would also allow some flexibility should the user need to add extra instruments at a later date. It is recommended that the power supply is able to supply at least 25mA per Sondaloop. If using the 21mA lost echo function 0.021 should be substituted for 0.020 in the above equation.



○ ○ ○ If you're having problems and suspect the load resistance is too high or are getting no current output display on the external equipment and you have no multimeter to check, temporarily programme the Sondaloop 'Lost Echo' to drive to 21mA then hold a rag firmly over the sensor, when the LCD reads 'LE' the output current should be 21mA. Check this is true on any external instruments. You can also do this with 4mA and 20mA to check the low and high levels. If you don't get any external readings its most probably a wiring fault. If the current is low it's most likely the load resistance.

5.1 Connection Diagrams

The Sondaloop can be used with a variety of controllers and power supplies. Hawker can provide the following units with connection diagrams.

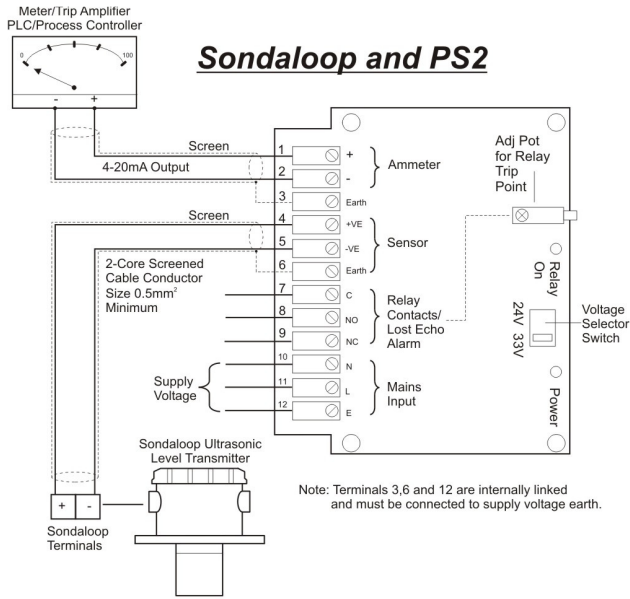

Sondaloop and Type 900

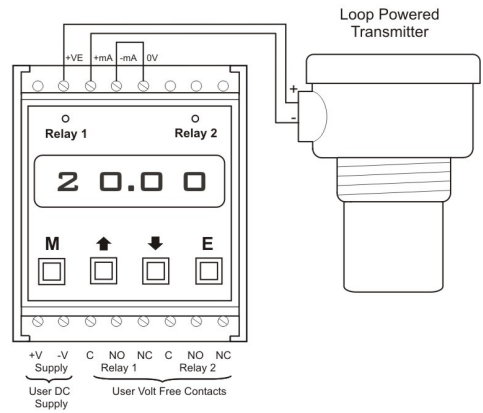

Sondaloop and DM224

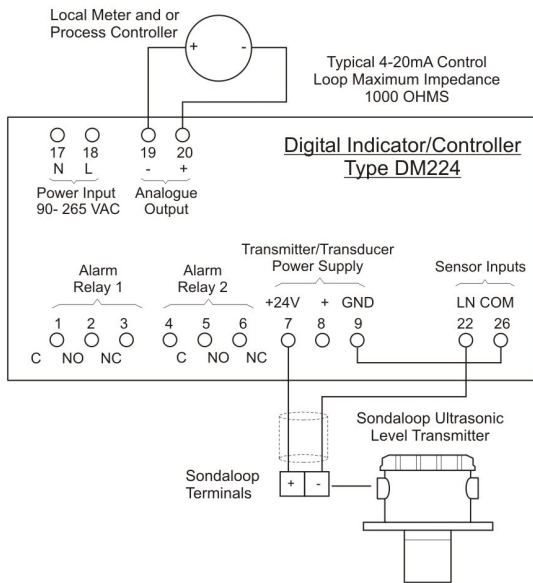

Sondaloop Remote

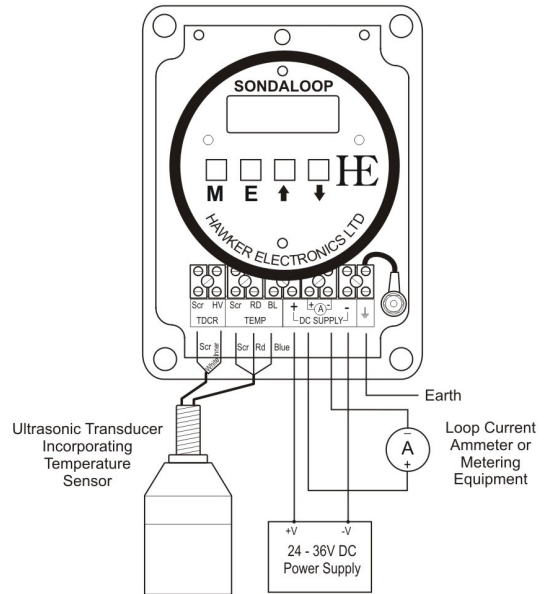

Sondaloop and Flexilevel

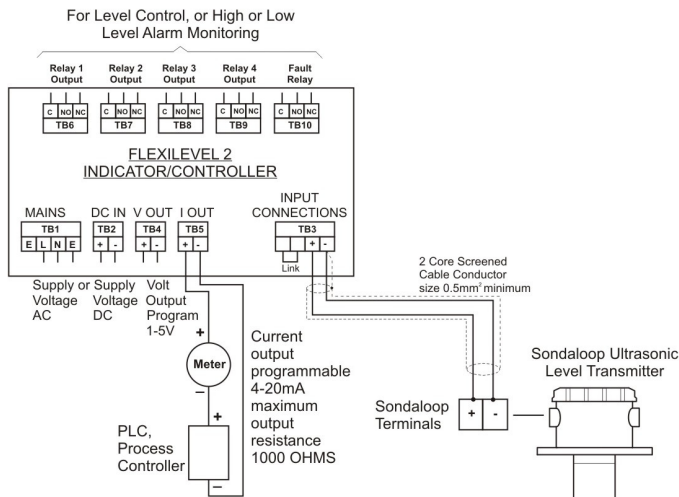

Sondaloop Connection

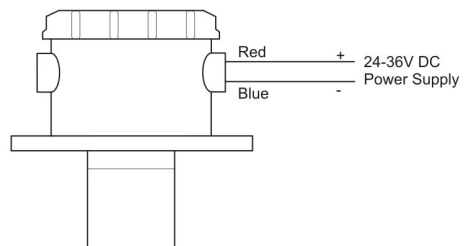

6.0 SCALING THE LEVEL FOR DEPTH OR DISTANCE

Setting the values representing the lower and upper levels of the liquid can be carried out manually if the parameters are known; otherwise it may be necessary to fill and empty the vessel to calibrate in auto mode.

If the 4mA point is programmed closer to the sensor face than the 20mA point the display will show in distance. If the 20mA is programmed closer to the sensor face than the 4mA setting the display will show depth. Either depth or distance can be expressed as a percentage which is software programmable.

Fig 6.1

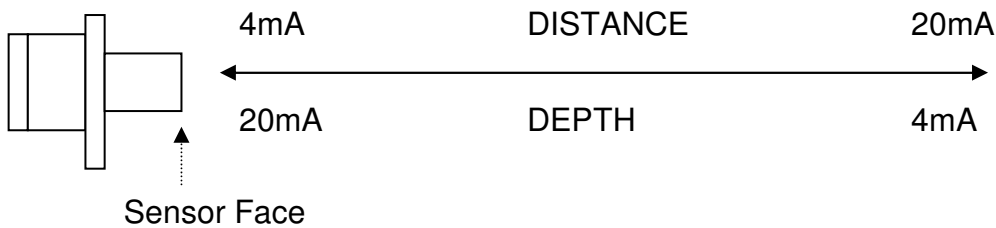

The Sondaloop measurement is always from the transmitter sensor face to the liquid. Depth is calculated in software by subtracting the distance to the liquid from the user programmed maximum depth.

6.1 Setting the Sondaloop to measure DEPTH

Fig 6.2

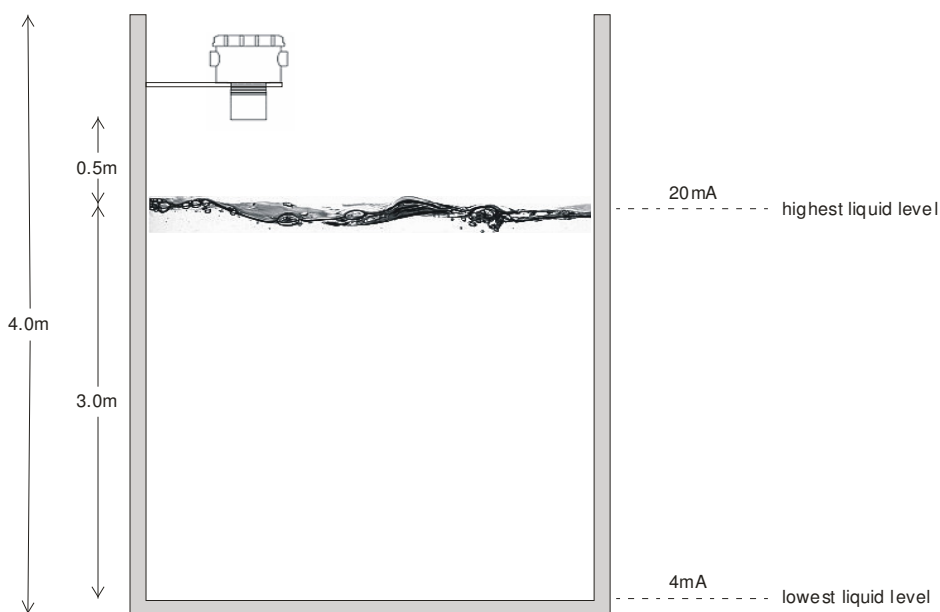

Assume a 4m high tank which fills to a maximum depth of 3m and the Sondaloop has been mounted so the sensor face is 0.5m above the highest liquid level (must never be less than 0.4m).

For depth mode programme the 20mA point as 0.500m and the 4mA point as 3.500m. The unit will give a 4mA to 20mA signal over the depth of 0m to 3.000m respectively.

In Summary

The 20mA point is the distance from the sensor face to the top water level.

The 4mA point is the distance from the sensor face to the lowest water level.

The depth is the difference between the top water level and bottom water level.

6.2 Setting the Sondaloop to measure DISTANCE

If the 4mA and 20mA points are reversed in the example above then the Sondaloop will be configured for distance measurement, i.e. if the 4mA point is programmed as 0.500m and the 20mA point is user programmed as 3.500m, the unit will give a 4 to 20mA signal over the range 0.5 to 3.500m respectively.

7.0 PROGRAMMING THE SONDALOOP

After applying power to the Sondaloop allow up to 5 seconds for the unit to stabilise, during this period the LCD may show random characters. Following this the LCD will briefly show the temperature in degrees centigrade and then a measurement in metres. Whilst displaying a measurement the decimal point will flash on and off, indicating to the user that the product is running ('run' mode). Approximately every minute thereafter the LCD will briefly show the temperature. The mA output current is not affected whilst the temperature is displayed.

Once the vessel dimensions and liquid levels are known the Sondaloop can be programmed, this is done by accessing the programme mode of the Sondaloop. Once in programme mode there are 3 basic operations in setting up the Sondaloop.

- 1 Scaling the level** in (A) MANUAL Mode (B) AUTO Mode
Entering the 4mA and 20mA values in metres

- 2 Setting the Display**
Configure the LCD to show the depth or distance in metres or as a percentage

- 3 Setting the Lost Echo**
The transmitter sends out a burst of energy then waits for the reflected pulse. If there are no reflected pulses the LCD will read 'LE' (Lost Echo). Under LE conditions the output current will be forced to '4mA', '20mA', '21mA' or 'Hold' the last good reading, user programmable. In applications where intermittent foam is prevalent the Hold option may be the preferred option. Where a loss of reflected echo is usual, then it will be application specific as to the best choice. 21mA is outside the normal range so can be used to identify a Lost Echo condition by external equipment.



Pressing the M key will jump back a level, several presses and it will return the Sondaloop to 'run' mode, indicated by a flashing decimal point.



Keeping a record of the programming values will ease programming should it need to be repeated or checked at a later date.

Step 1 Scaling the 4mA level

(A) Setting up in **MANUAL Mode**

Operation	Display	Notes
Press M	XX:XX	Decimal point disappears, LCD characters freeze and the colon is fixed
Press ↑↓↑↓	Ent	LCD reads - - - - when up/down keys pressed
Press E	4mA	This is the low level setting (depth mode)
Press E	X.XXX	Set the 4mA point. Use the ↑↓ arrows until you reach the number you want.
Press E	donE 4mA	You have now stored the number manually in the memory
Press M	Ent	You are leaving the Manual set up
Press M	X X:XX	
Press M	X.XXX	Flashing decimal point indicates system is running

(B) Setting up in **AUTO Mode**

Operation	Display	Notes
Press M	X:XX	Decimal point disappears, LCD characters freeze and the colon is fixed
Press ↑↓↑↓	Ent	LCD reads - - - - when up/down keys pressed
Press ↑	Auto	You are entering Auto set-up
Press E	4mA	This is your 4mA low setting (depth mode)
Press E	X.XXX	Decimal point starts flashing; you can hear the sensor ticking. Ensure the tank is empty. Wait until the LCD displays a correct stable measurement before pressing Enter.
Press E	donE 4mA	LCD displays 'done' momentarily then 4mA. You have now stored the tank empty value automatically in the memory
Press M	Auto	You are leaving the Auto set up
Press M	X X:XX	
Press M	X.XXX	Flashing decimal point indicates system is running

Scaling the 20mA level

(A) Setting up in **MANUAL Mode**

Operation	Display	Notes
Press M	X:XX	Decimal point disappears, LCD characters freeze and the colon is fixed
Press ↑↓↑↓	Ent	LCD reads - - - - when up/down keys pressed
Press E	4mA	
Press ↑	20mA	This is the High level setting (depth mode)
Press E	X.XXX	Set the 20mA point. Use the ↑↓ arrows until you reach the number you want.
Press E	donE 20mA	LCD displays 'done' momentarily then 20mA. You have now stored the tank full value automatically in the memory
Press M	Ent	You are leaving the Manual set up
Press M	XX:XX	
Press M	X.XXX	Flashing decimal point indicates system is running

(B) Setting up in AUTO Mode

Operation	Display	Notes
Press M	XX:XX	Decimal point disappears, LCD characters freeze and the colon is fixed
Press ↑↓↑↓	Ent	LCD reads - - - when up/down keys pressed
Press ↑	Auto	You are entering Auto set-up
Press E	4mA	
Press ↑	20mA	This is your 20mA High setting (depth mode)
Press E	X.XXX	Decimal point starts flashing; you can hear the sensor ticking. Ensure the tank is full. Wait until the LCD displays a correct stable measurement before pressing Enter.
Press E	donE 20mA	LCD displays 'done' momentarily then 20mA. You have now stored the tank full value automatically in the memory
Press M	Auto	You are leaving the Auto set up
Press M	XX:XX	
Press M	X.XXX	Flashing decimal point indicates system is running

Step 2 Setting the Display, metres or percentage

Operation	Display	Notes
Press M	XX:XX	Decimal point disappears, LCD characters freeze and the colon is fixed
Press ↑↓↑↓	Ent	LCD reads - - - when up/down keys pressed
Press ↑	Auto	
Press ↑	diSP	This is the display set-up.
Press E	dEP / dist or PErC	Will show either 1. Depth or distance, not both ¹ 2. or %.
Press ↑	PErC	Use the up or down key to scroll to the desired setting
Press E	donE dEP	Momentarily displays 'done' then whichever the user has chosen. The choice is now stored in memory, in this example depth
Press M	dISP	You are leaving the display set up
Press M	XX:XX	
Press M	X.XXX	Flashing decimal point indicates system is running

¹If the 4mA setting is set closer to the sensor face than the 20mA, the menu will give the option of distance (diSt) or percentage (PerC).

If the 20mA setting is set closer to the sensor face than the 4mA the display will give the option of depth (dEP) or percentage (PerC).

Step 3**Setting the Lost Echo (LE)**

	Display	Notes
Press M	XX:XX	Decimal point disappears, LCD characters freeze and the colon is fixed
Press ↑↓↑↓	Ent	
Press ↑	Auto	
Press ↑	diSP	
Press ↑	LE	This is the Lost Echo set-up
Press E	XXmA	
Press ↑ or ↓	XXmA	Use the up or down key to toggle through the desired options 4, 20, 21mA or HOLD
Press E	donE XXmA	Momentarily displays 'done' then XXmA. Pressing Enter stores the chosen setting as the Lost Echo value
Press M	LE	You are leaving the Lost Echo set up
Press M	XX:XX	
Press M	X.XXX	Flashing decimal point indicates system is running

When the Sondaloop is in the normal 'run' mode the LCD will have a flashing decimal point. If the decimal point is not flashing and the unit is not under or over range (see next paragraph) the Sondaloop will not make any measurements.

If the LCD shows an over-range signal - - - - or an under-range signal _ _ _ _ the liquid measurement is outside the range programmed by the user. This may or may not be a problem, if only a few millimetres it can be ignored, but if it is several centimetres the user may wish to consider re-programming the unit. This sometimes happens when vessels are filled or emptied slightly more than usual. If left, the system will automatically resume normal operation when normal conditions return. Careful user programming allowing for application variations will eliminate this.

Step 4. Additional Software Feature

Generation of 4,20 and 21mA signals using the MiniSonda

Applicable models: MiniSonda supplied after June 2016. This additional software feature can be accessed from the main menu under 'SEnd' sub menu.

To help calibrate any externally connected equipment to the MiniSonda such as a Flexilevel 2 or BMS system the MiniSonda can now be used to generate 4, 20 and 21mA signals via its keypad. This feature effectively simulates an empty or full vessel removing any need to physically empty and fill the vessel during commissioning. Additionally the MiniSonda can generate a 21mA signal to simulate the Lost Echo function. This feature is accessed from 'SEnd' in the main menu.

Operation	Display	Notes
Press M	XX:XX	Decimal point disappears, LCD characters freeze and the colon is fixed
Press ↑↓↑↓	Ent	LCD reads - - - - when up/down keys pressed
Press ↓	SEnd	Sub Menu to access current calibrator
Press E	4mA	4mA is sent to the loop
Press ↑	20mA	20mA is sent to the loop
Press ↑	21mA	21mA is sent to the loop
Press M	SEnd	Exiting the calibrator mode
Press M	XX:XX	Will display a number with a stationary semicolon
Press M	X.XXX	Run mode will display the measured value, decimal point flashes in run mode

Note: Both up and down keys can be used to alter mA sent to loop e.g. it rotates up and down through sequence

4mA ↑ 20mA ↑ 21mA ↓ 4mA ↓ 21mA ↓ 20mA

Remember to disconnect any external equipment e.g. pumps, motors, alarms etc from the main controller if you do not want them to operate whilst in 'SEnd' mode.

IMPORTANT

When scrolling through the menu options (LE, Display), the software allows the user to try the settings before committing to memory. For example if the lost echo has been stored as 20mA, but the user enters program mode and scrolls through the lost echo settings until 4mA is displayed, (Do Not Press Enter), then presses the 'M' key until the unit is back in 'RUN' mode, the unit will now drive to 4mA under lost echo conditions. This can be useful for diagnostic purposes or for temporarily driving external equipment to a different value than programmed. To resume the normal setting's return to the menu mode and leave it displaying the original setting or alternatively simply disconnect the power for a few seconds then re-apply the power.

8.0 TROUBLE SHOOTING

Symptom	Cause	Action
Gives Lost Echo LE	Target out of range Application Dusty or steamy Excess foam on liquid	Check system specification Check installation & Tank condition Re-site Transducer
Reading Static when level changes	Unit processing wrong target	Move transducer to better location
No loop current output	Power Failure	Check Power supply and output to Sondaloop and load resistance isn't too high
Reading Erratic False Reading	Target Unsteady Target within dead-band Fumes Electrical Noise Obstructions present Detecting the end of a guide tube or getting multiple echoes	Move transducer to a better location Raise transducer >0.4m above top water level Check installation Move transducer to a better location Check under target for obstruction, if guide pipe is used ensure it is clear
Reading - - - - Or _ _ _ _	Target outside top or bottom water level, (outside the programmed values).	This may only be by a small amount ~1mm so check levels and Re-calibrate system if necessary
Reading occasionally goes high when vessel is not full. Output current and LCD reading ramps up and down	Spurious echo detected, Acoustic coupling to bracket, Detecting the end of a stilling pipe or guide tube	Move transducer to a better location Ensure the unit is not directly mounted to metal or metal mounting bolts are not used. Loosen nylon mounting bolts. Use foam gasket Alter guide tube arrangement
Failure to operate correctly at mid to high range current	Load resistance too great	Check load resistance isn't too high. Check equipment connected to loop.
'Err' display on LCD whilst programming the 4mA & 20mA points	4mA and 20mA points set to close	Re-span so the range is >100mm
No measurement, LCD decimal point is stationary or Stationary dash/digit on LCD	Sondaloop is in Programme mode	Press the 'M' key repeatedly until the decimal point flashes.

EU DECLARATION OF CONFORMITY

1. **Product Model:** Sondaloop, MiniSonda Ultrasonic Level Transmitter
2. **Manufacturer:** Hawker Electronics Ltd, 57 The Avenue, Rubery Industrial Estate, Rubery, Birmingham, B45 9AL
3. **This declaration of conformity is issued under the sole responsibility of the manufacturer.**
4. **Object of the declaration:**
5. The object of the declaration described above is in conformity with the relevant **Union harmonised legislation:**
 - **EMC Directive (2014/30/EU)**
 - **RoHS Directive (2011/65/EU)**
6. Reference to the relevant **harmonised standards** used in relation to which conformity is declared:
 - EMC EN 50081/2 Generic Standards using EN 55011 Limits and Methods
 - EN 55011 Conducted Emissions, class A
 - EN 55011 Radiated Emissions, class A
 - EN 61000-4-2 Immunity to ESD, cat 1
 - EN 61000-4-4 Immunity to fast transient bursts, cat 1
 - EN 61000-4-3 Immunity to Radiated Fields, class A

7. Notified Body N/A

8. Additional Information:

The product named above complies with the parts of the standards listed. The company operates an internal production control system that ensures compliance between the manufactured products and the technical documentation. Compliance may be based on similar products or variants that have satisfactory completed full testing. RoHS compliant components are used in the manufacture of the this product.

Signed for and on behalf of:

Hawker Electronics Ltd on 20th April 2016

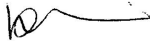

JJ Slevin (Managing Director)