

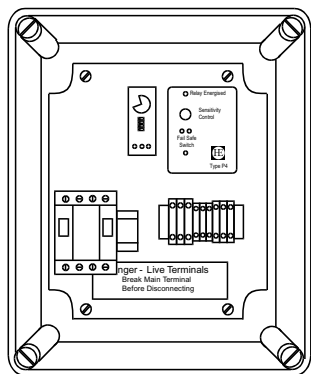

HAWKER

LEVEL CONTROL SYSTEMS

Special Purpose Level Controllers for Conducting Liquids AC Plus Level Control & Pump Motor Starter Gear



MMO

Models Available

MMO for single phase pump motor up to 2.2kW (3hp) comprising:
Plastic weatherproof enclosure with clear lid
P4 level controller plus contactor. All prewired to terminals. Extras available
/T Timer for single electrode operation.
/P Push button to restart manually.

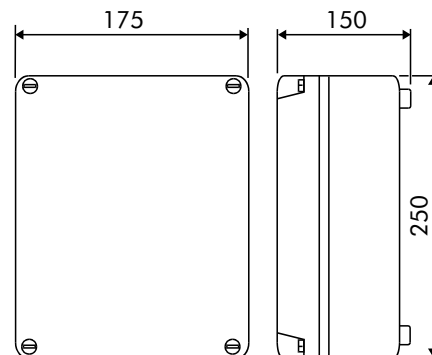

MMO in plastic enclosure to IP65

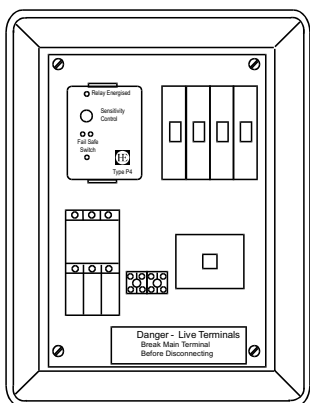

MM1 & MM1/3

MM1 for single phase pump motor up to 4kW (5.5hp).

MM1/3 for 3 phase 4 wire pump motor up to 7.5kW (10hp)

MM3 for 3 phase 3 wire pump motor up to 7.5kW (10hp). Complete with isolating transformer. Extras available.

/I Door locking isolator.

/O Overloads.

/S Hand-off-auto switch.

/L Pump Running Light.

Electrode Connections

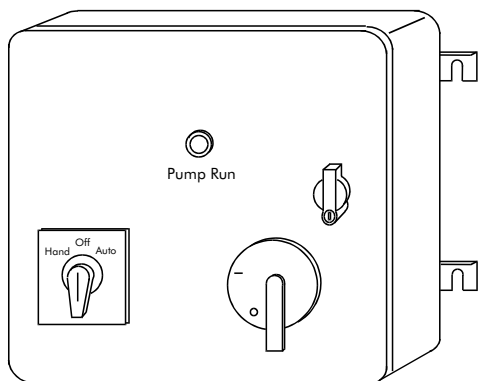
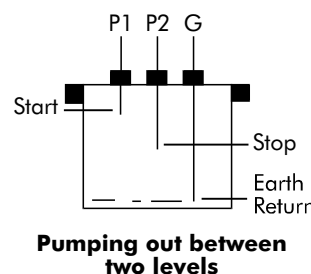
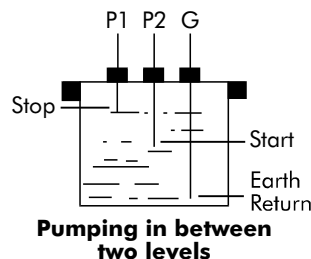

MM3

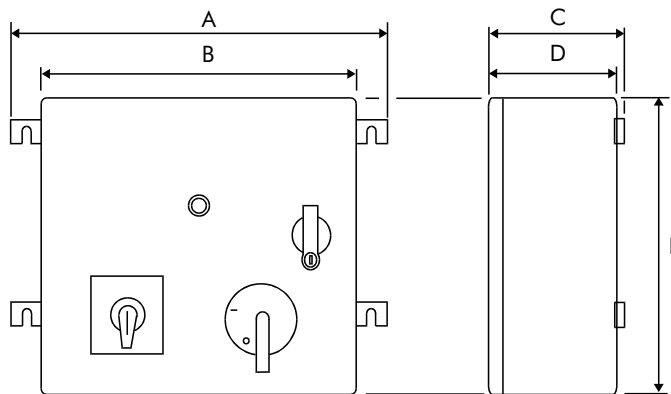

Dimensions mm	A	B	C	D	E	Weight
MM1 & MM1/3	280	218	152	140	318	7 Kgs
MM3	388	318	165	162	318	10.4 Kgs

See Data Sht No 233 for connection diagrams for the above units

MM1, MM1/3 and MM3
Sheet Metal Enclosure

AC8
3 Pump Controller

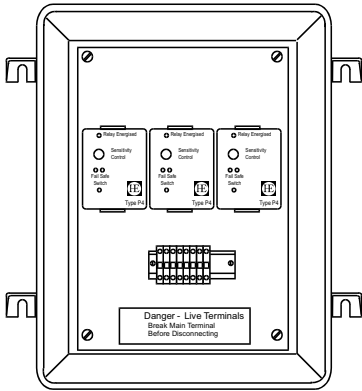

Wall mounting level control unit designed for 3 pumps operating in cascade which start and stop at the requisite levels set by the electrode lengths.

Also incorporated is a selector switch to interchange the starting order in sequence

1: 2: 3, 2: 3:1 & 3:1: 2.

AC8/L pumping out applications (F.S.L.)

AC8/H pumping in applications (F.S.H.)

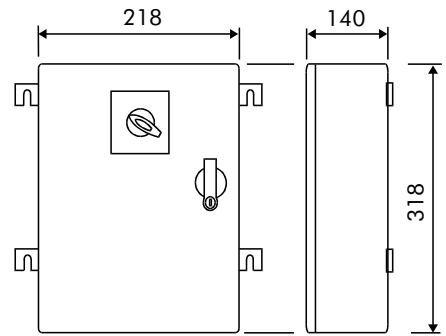

AC8
Sheet Metal Enclosure

118
Level Controller

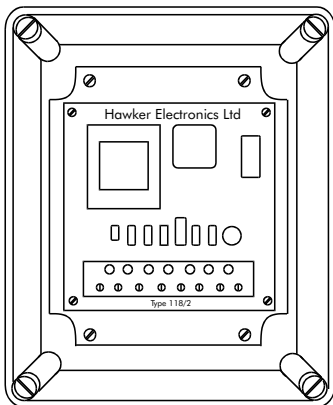

Level Control for clean liquid applications or high level alarm in sewage etc. The fail safe and the fixed conductivity are set at works to order. Available in a plastic weatherproof enclosure or chassis only. Types are:-

1. 118 - 110V or 240V 50 Hz, supply with small AC current on the electrodes

2. DC118 - 12V or 24V DC supply small DC current on electrodes.

3. AC/DC 118 similar to DC118 but with 110V or 240V 50 Hz supply.

2. and 3. enable long distances between controller and electrodes.

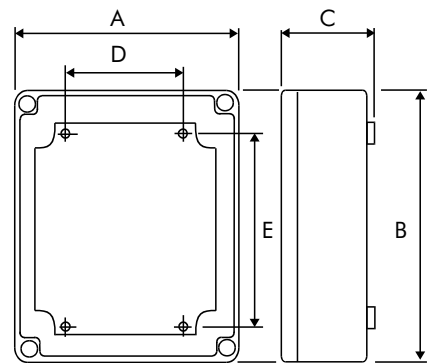

Dimensions mm	A	B	C	D	E
118	134	170	85	65	130
AC/DC 118	172	222	105	130	150

118, AC/DC
Plastic
weatherproof enclosures

LP3 Pump dry running protector

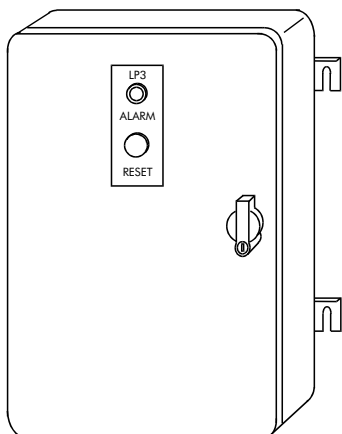

LP3 Pump dry running protector. Controlled by a small sensor in the pump suction line. Adequate safeguards against pump priming period, aeration etc. Integral and remote alarms. Available as chassis or in a sheet metal enclosure. Supply voltages 110V or 240V 50 Hz.

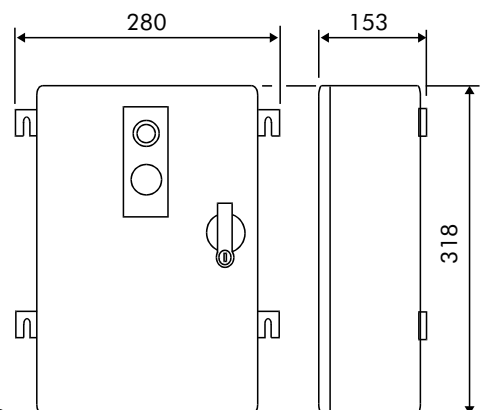

See Data Sht No 233 for connection diagrams for the above controllers

Because of continuing development we reserve the right to change the specifications without notice.
For a full list of HAWKER products and application notes visit our web site at www.hawker-electronics.co.uk

HAWKER ELECTRONICS LTD.

57 The Avenue,
Rubery Industrial Estate,
Birmingham B45 9AL, ENGLAND
Telephone : +44 (0)121-453-8911 Fax : +44(0)121-453-3777
e.mail: info@hawker-electronics.co.uk



D617.cdr