

Plan

Ø74mm dia semi-spherical recess in gravitational centre of block for pin anchor.
(pin anchor is rated to 2.5 tonnes with a safety factor of 3).

Total Block Weight : 533Kg.

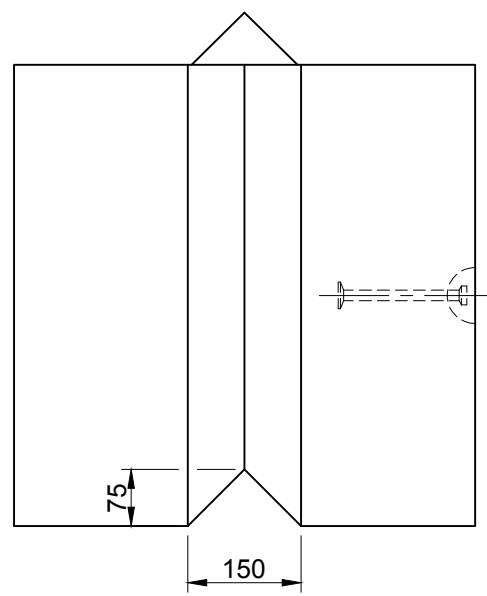

End

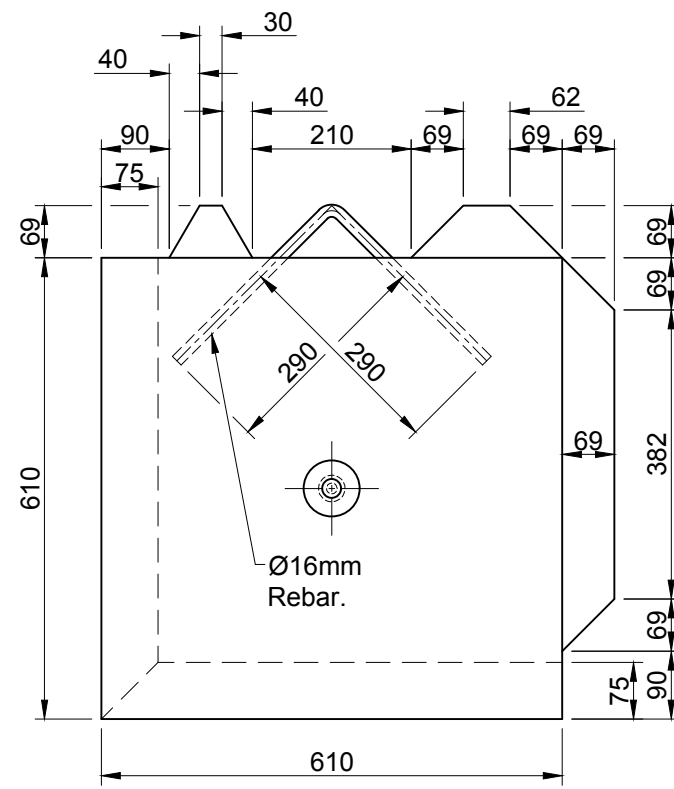

Elevation

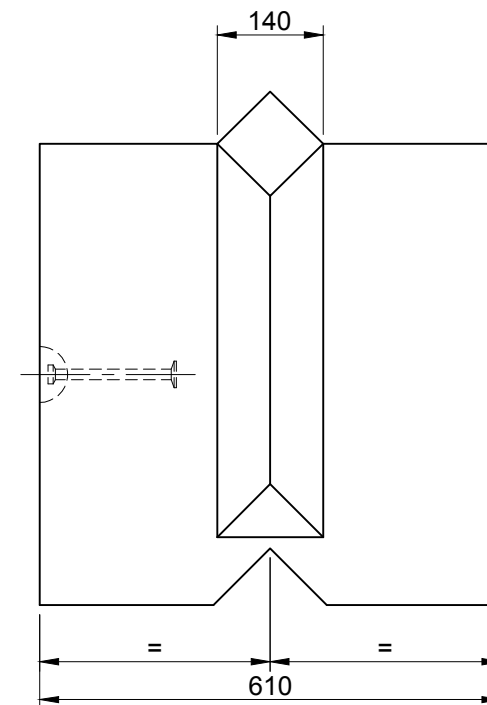

End

ALL Vee™ Interlocking Concrete Blocks are manufactured using high strength (50N/mm²) concrete and are Class A1 fire resistant in accordance with clause 4.3.4.4 of EN 13369.

										TITLE				ELITE PRECAST CONCRETE LTD HALESFIELD 9, TELFORD SHROPSHIRE TF7 4QW					
										Vee™ Interlocking Concrete Block 610 x 610 x 610 Elite Product Code : B1-610 also KV533				SIZE A3 SCALE 1:10 DRG EPC-VEE-005					
REV	DATE	REASON FOR ISSUE	DRN	APP	REV	DATE	REASON FOR ISSUE	DRN	APP	CTC	RMD	CHKD	RMD	DATE	28-06-16	DRG	EPC-VEE-005	REV	O