

PROJECTION

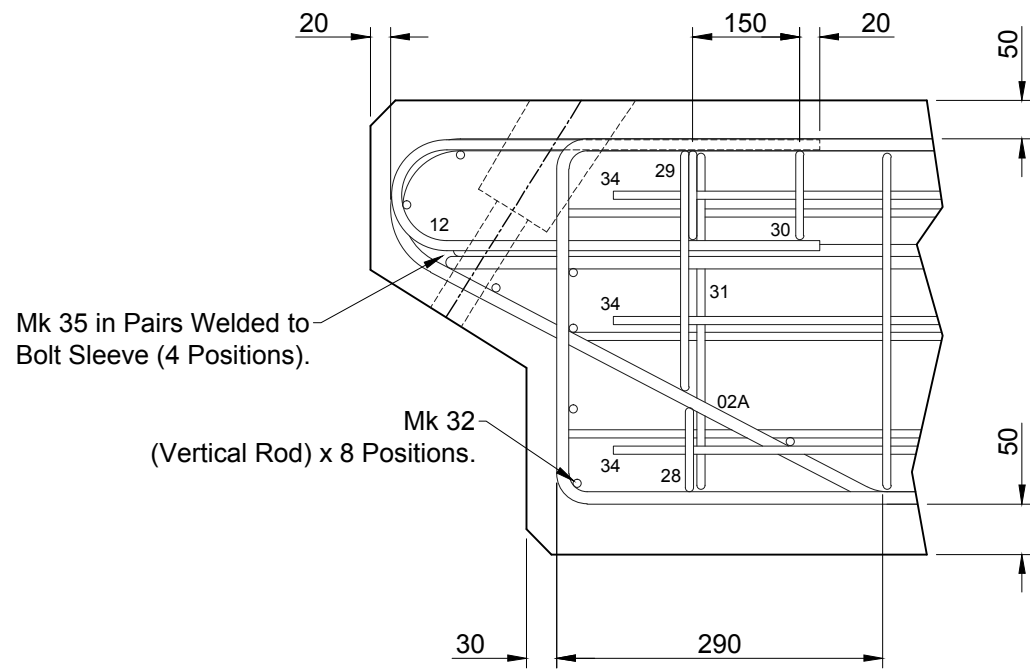
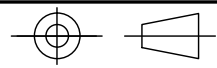

Mk 35 in Pairs Welded to Bolt Sleeve (4 Positions).

Mk 32 (Vertical Rod) x 8 Positions.

Enlarged Detail

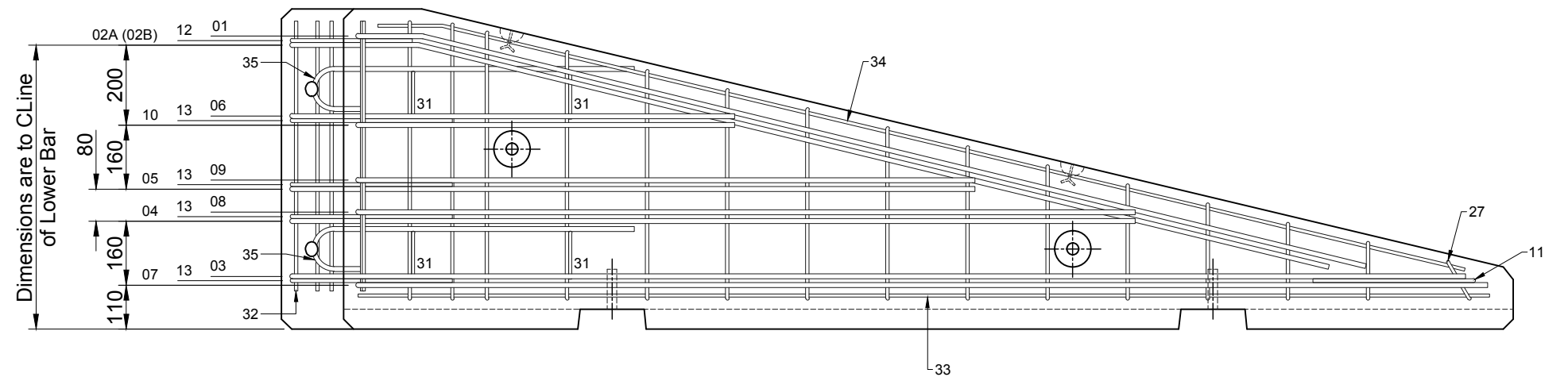
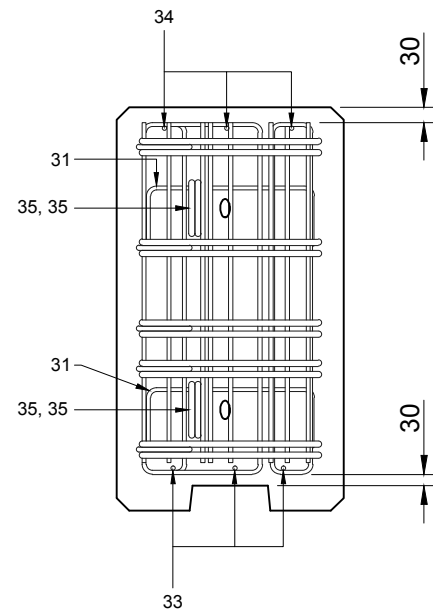
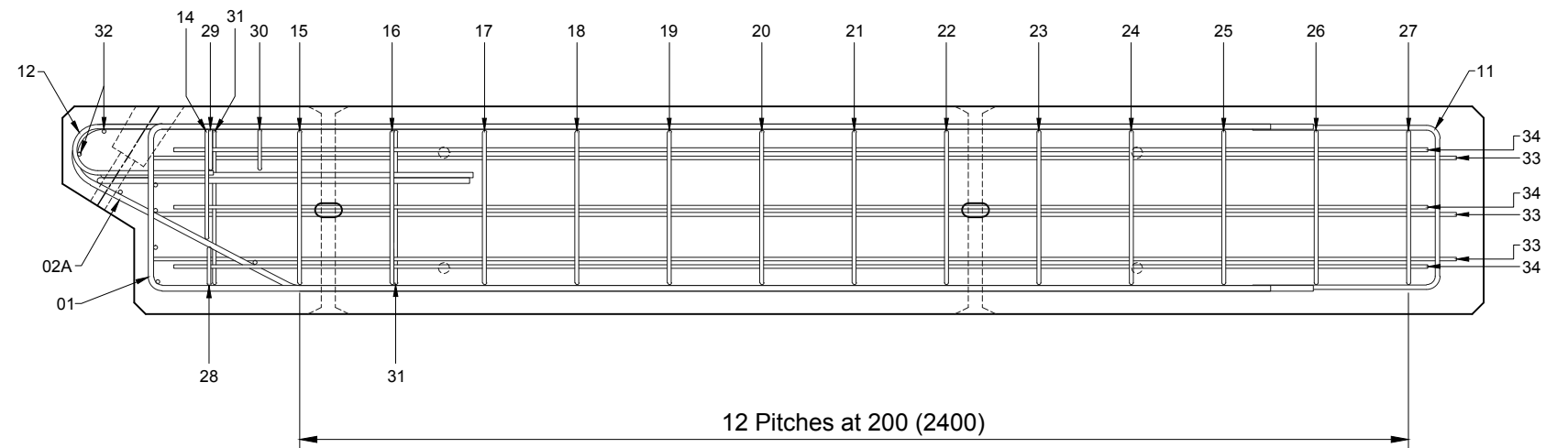

Item No.	Orientation	Remarks
V1	As Drawn	Verge (use bar mark 02A)
V2	Opp. Hand	Central Reserve (use bar mark 02B)

Notes

- Dimensions in millimetres
- This drawing to be read in conjunction with drawing 158.
- For bar schedule refer to drawing 160.
- Normal cover to reinforcement to be 50mm unless otherwise stated.

				O 26.03.14 For Information				CTC	RD				
REV	DATE	REASON FOR ISSUE	DRN	APP	REV	DATE	REASON FOR ISSUE	DRN	APP				
TITLE :				ELITE PRECAST CONCRETE LIMITED HALESFIELD 9, TELFORD SHROPSHIRE TF7 4QW									
Temporary Vertical Concrete Barrier (TVCB) Terminal Unit - Reinforcement Details Elite Product Code : -													
DRN :	CTC	CHKD :	RD	DATE :	26-03-14	DRG SIZE :	A3	SCALE :	1:15	DRG	159	REV	O